

ASSEMBLY INSTRUCTIONS

INSTRUCTIONS DE MONTAGE

FULL SIZE BUNK BED WITH SLIDE AND LADDER

LIT SUPERPOSÉ PLEINE GRANDEUR AVEC TOBOGGAN ET
ÉCHELLE

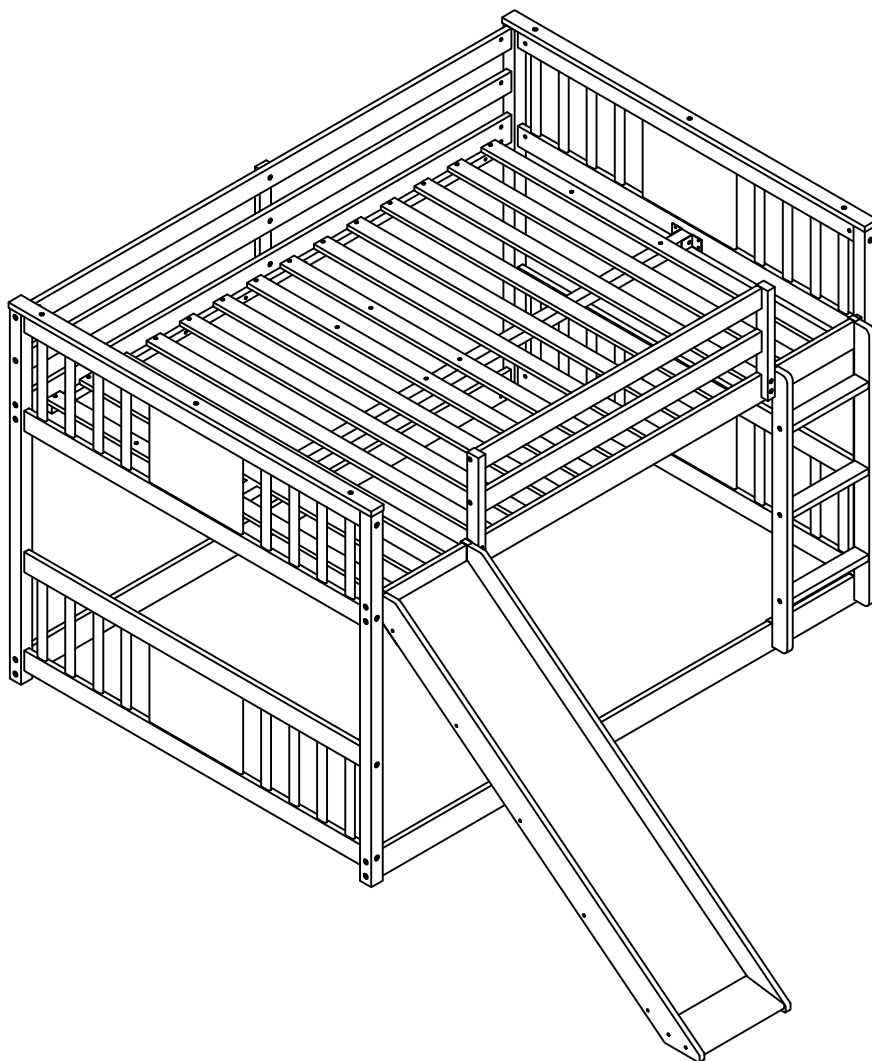



SAFETY WARNING



1. This bed is designed for use only mattress (es) meeting the following specifications on the upper bunk.

Upper bunk (Bunk bed and tribed included)

Bed type	Length	Width	Thickness
Full Standard	74"-75"	54"	6"

2. Replacement parts, including additional guardrails, maybe obtained from any of our dealers.
3. Follow the information on the warnings appearing on the upper bunk bed end structure and on the carton. Do not remove warning label from bed.
4. Always use the recommended size mattresses or mattress supports, or both, to help prevent the likelihood of entrapment or falls.
5. Surface of mattress must be at least 5" (127mm) below the upper edge of guardrails.
6. Do not allow children under 6 years of age to use the upper bunk.
7. Periodically check and ensure that the guardrail, ladder, and other components are in their proper position, free from damage, and that all connectors are tight.
8. Do not allow horseplay on or under the bed and prohibit jumping on the bed.
9. Always use the ladder for entering and leaving the upper bunk.
10. Do not use substitute part. Contact the manufacture or dealer for replacement part.
11. Use of a night light may provide added safety precaution for a child using the upper bunk.
12. Always use guardrails on both long sides of the upper bunk. If the bunk bed will be placed next to the wall, the guardrail that runs the full length of the bed should be placed against the wall to prevent entrapment between the bed and wall.
13. The use of water or sleep flotation mattresses is prohibited.
14. STRANGULATION HAZARD - Never attach or hang items to any part of the bunk bed that are not designed for use with the bed; for example, but not limited to, hook, belts and jump ropes.
15. Keep these instruction for future reference.
16. Prohibit more than one person on upper bunk
17. We recommend assembling your bunk bed on the shipping carton to protect your floor or carpet.
18. Be certain all staples are out of the box before beginning assembly on the shipping carton.



ALERTE DE SÉCURITÉ



1. Ce lit est conçu pour utiliser uniquement des matelas répondant aux spécifications suivantes sur la couchette supérieure.

Couchette supérieure (Lits superposés et triblés inclus)

Type de lit	Longueur	Largeur	Épaisseur
Double Standard	74"-75"	54"	6"

2. Des pièces de rechange, y compris des garde-corps supplémentaires, peuvent être obtenues auprès de l'un de nos revendeurs

3. Suivez les informations sur les avertissements apparaissant sur la structure d'extrémité supérieure du lit superposé et sur le carton. Ne retirez pas l'étiquette d'avertissement du lit.

4. Utilisez toujours des matelas ou des supports de matelas de taille recommandée, ou les deux, pour éviter tout risque de coincement ou de chute.

5. La surface du matelas doit être à au moins 5" (127 mm) sous le bord supérieur des garde-corps.

6. Ne laissez pas les enfants de moins de 6 ans utiliser le lit supérieur.

7. Vérifiez et assurez-vous périodiquement que le garde-corps, l'échelle et les autres composants sont dans leur bonne position, exempts de dommages et que tous les connecteurs sont bien serrés.

8. Ne permettez pas les chahuts sur ou sous le lit et interdisez de sauter sur le lit.

9. Utilisez toujours l'échelle pour entrer et sortir du lit supérieur.

10. N'utilisez pas de pièce de rechange. Contactez le fabricant ou le revendeur pour obtenir une pièce de rechange.

11. L'utilisation d'une veilleuse peut fournir une mesure de sécurité supplémentaire pour un enfant utilisant le lit supérieur.

12. Utilisez toujours des garde-corps sur les deux côtés longs du lit supérieur. Si le lit superposé doit être placé à côté du mur, le garde-corps qui s'étend sur toute la longueur du lit doit être placé contre le mur pour éviter tout coincement entre le lit et le mur.

13. L'utilisation de matelas flottants à eau ou de sommeil est interdite.

14. **RISQUE D'ÉTRANGULATION** - N'attachez ou ne suspendez jamais d'objets à une partie du lit superposé qui ne sont pas conçus pour être utilisés avec le lit ; par exemple, mais sans s'y limiter, les crochets, les ceintures et les cordes à sauter.

15. Conservez ces instructions pour référence future.

16. Interdire plus d'une personne sur la couchette supérieure.

17. Nous vous recommandons d'assembler votre lit superposé sur le carton d'expédition pour protéger votre sol ou votre tapis.

18. Assurez-vous que toutes les agrafes sont sorties de la boîte avant de commencer l'assemblage sur le carton d'expédition.





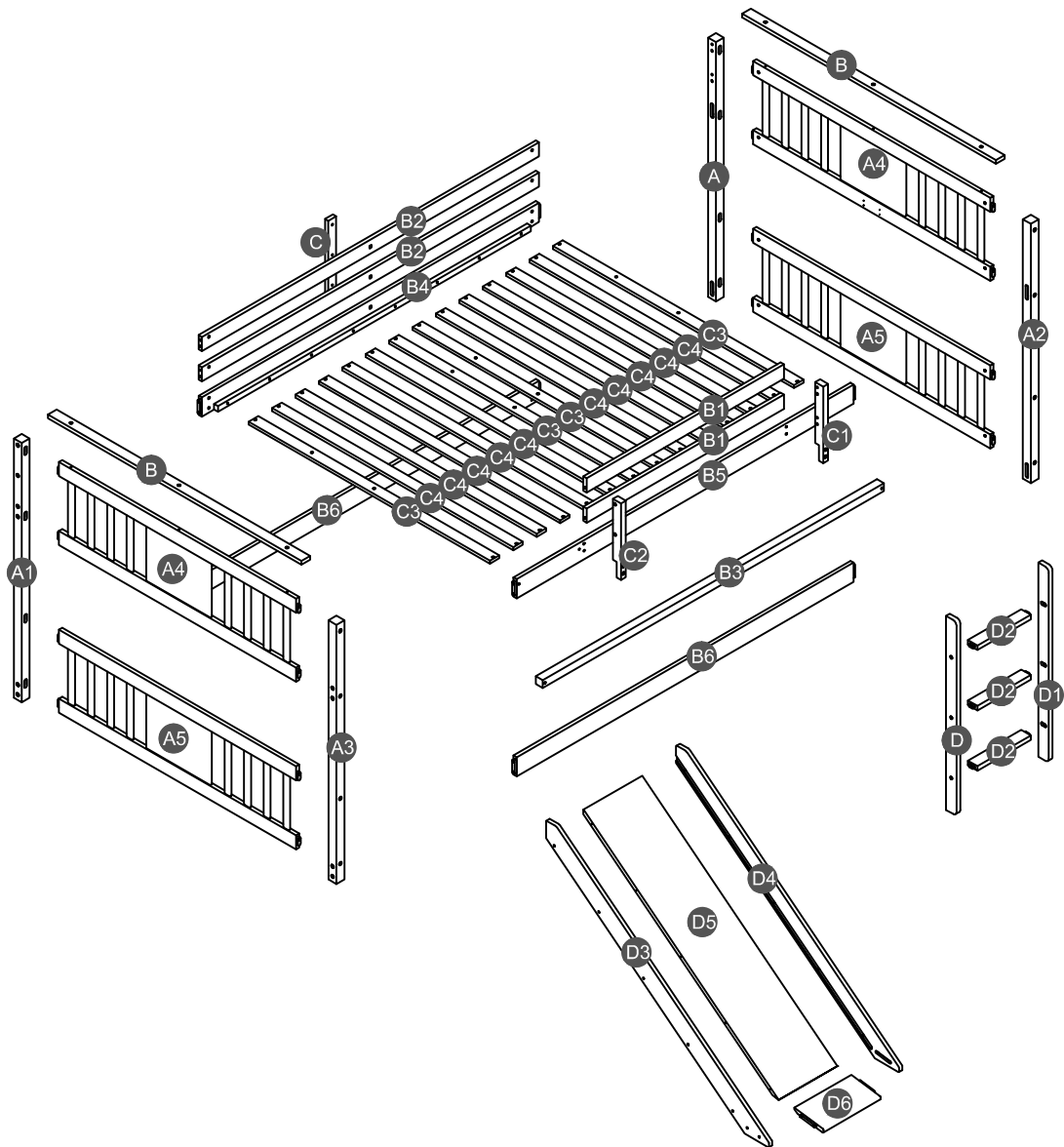



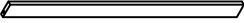

Detail View

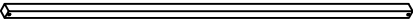
Vue Détaillée











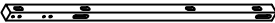
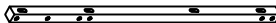

Part list (Box 1)

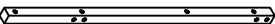
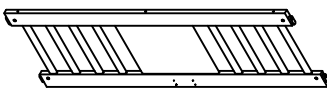
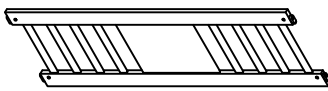
Liste des pièces (Boîte 1)

<p>B</p>  <p>Cap bar - 2pcs Barre de casquette</p>	<p>B1</p>  <p>Short guard rail (Front) - 2pcs Garde-corps court (Avant)</p>	<p>B2</p>  <p>Long guard rail (Back) - 2pcs Garde-corps long (Arrière)</p>
<p>B3</p>  <p>Lower support slat - 1pc Latte de support inférieure</p>	<p>B4</p>  <p>Upper side rail (Back) - 1pc Rail latéral supérieur (Arrière)</p>	<p>B5</p>  <p>Upper side rail (Front) - 1pc Rail latéral supérieur (Avant)</p>
<p>B6</p>  <p>Lower side rail - 2pcs Rail latéral inférieur</p>	<p>C</p>  <p>Vertical guard rail (Back) - 1pc Garde-corps vertical (Arrière)</p>	<p>D3</p>  <p>Left side slide - 1pc Glissière côté gauche</p>
<p>D4</p>  <p>Right side slide - 1pc Glissière côté droit</p>	<p>D5</p>  <p>Slide panel - 1pc Panneau coulissant</p>	<p>D6</p>  <p>Slide base support - 1pc Support de base coulissante</p>

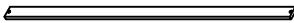
Part list & Hardware list (Box 2)

Liste des pièces & liste du matériel (Boîte 2)

<p>A</p>  <p>Leg (Right back) - 1pc Pied (Arrière droit)</p>	<p>A1</p>  <p>Leg (Left back) - 1pc Pied (Arrière gauche)</p>	<p>A2</p>  <p>Leg (Right front) - 1pc Pied (Avant droite)</p>
<p>A3</p>  <p>Leg (Left front) - 1pc Pied (Avant gauche)</p>	<p>A4</p>  <p>Upper HB frame - 2pcs Cadre supérieur HB</p>	<p>A5</p>  <p>Lower HB frame - 2pcs Cadre HB inférieur</p>
<p>C1</p>  <p>Vertical guard rail (right) - 1pc Garde-corps vertical (droit)</p>	<p>C2</p>  <p>Vertical guard rail (left) - 1pc Garde-corps vertical (gauche)</p>	<p>C3</p>  <p>Slat - 4pcs Latte</p>
<p>C4</p>  <p>Slat - 10pcs Latte</p>	<p>D</p>  <p>Left side ladder - 1pc Échelle côté gauche</p>	<p>D1</p>  <p>Right side ladder - 1pc Échelle côté droit</p>
<p>D2</p>  <p>Step ladder - 3pcs Escabeau</p>		

Hardware List (Box 2)

Liste du matériel (Boîte 2)

<p>1</p>  <p style="text-align: center;">Ø10*40mm</p> <p style="text-align: center;">Wood dowel (8pcs) Cheville en bois</p>	<p>2</p>  <p style="text-align: center;">(Ø15)1/4"*100mm</p> <p style="text-align: center;">Hex-Head bolts (20pcs) Boulons à tête hexagonale</p>	<p>3</p>  <p style="text-align: center;">(Ø15)1/4"*80mm</p> <p style="text-align: center;">Hex-Head bolts (20pcs) Boulons à tête hexagonale</p>
<p>4</p>  <p style="text-align: center;">(Ø12)1/4"*60mm</p> <p style="text-align: center;">Hex-Head bolts (6pcs) Boulons à tête hexagonale</p>	<p>5</p>  <p style="text-align: center;">(Ø12)1/4"*40mm</p> <p style="text-align: center;">Hex-Head bolts (4pcs) Boulons à tête hexagonale</p>	<p>6</p>  <p style="text-align: center;">(Ø12)1/4"*35mm</p> <p style="text-align: center;">Hex-Head bolts (4pcs) Boulons à tête hexagonale</p>
<p>7</p>  <p style="text-align: center;">(Ø12)1/4"*30mm</p> <p style="text-align: center;">Hex-Head bolts (3pcs) Boulons à tête hexagonale</p>	<p>8</p>  <p style="text-align: center;">1/4"*15 (9.5mm)</p> <p style="text-align: center;">Horizontal-Hole bolts(46pcs) Boulons à tête hexagonale</p>	<p>9</p>  <p style="text-align: center;">(Ø12)1/4"*40mm</p> <p style="text-align: center;">Hex-Head bolts (6pcs) Boulons à tête hexagonale</p>
<p>10</p>  <p style="text-align: center;">(Ø12)1/4"*50mm</p> <p style="text-align: center;">Hex-Head bolts (14pcs) Boulons à tête hexagonale</p>	<p>11</p>  <p style="text-align: center;">Ø4*30mm</p> <p style="text-align: center;">Wood screws (36pcs) Vis</p>	<p>12</p>  <p style="text-align: center;">116*40*27mm</p> <p style="text-align: center;">Metal bracket (2pcs) Support métallique</p>
<p>13</p>  <p style="text-align: center;">Ø3.5*15mm</p> <p style="text-align: center;">Wood screws (8pcs) Vis</p>	<p>14</p>  <p style="text-align: center;">Ø4*19mm</p> <p style="text-align: center;">Wood screws (12pcs) Vis</p>	<p>15</p>  <p style="text-align: center;">81*26*21mm</p> <p style="text-align: center;">Metal bracket (4pcs) Support métallique</p>
<p>16</p>  <p style="text-align: center;">(Ø13)1/4"*14mm</p> <p style="text-align: center;">Connect bolt (2pcs) Connecter le boulon</p>	<p>17</p>  <p style="text-align: center;">Ø13"*3mm</p> <p style="text-align: center;">Spring Washer (14pcs) Rondelle à ressort</p>	<p>18</p>  <p style="text-align: center;">142*18*2mm</p> <p style="text-align: center;">Hooks (2pcs) Crochets</p>
<p>19</p>  <p style="text-align: center;">(1/4")4.5*58mm</p> <p style="text-align: center;">Allen key (2pcs) Clé Allen</p>		

ASSEMBLY TOOLS REQUIRED (NOT INCLUDED)

OUTILS D'ASSEMBLAGE REQUIS (NON INCLUS)



 (Phillip head screwdriver)



PLEASE BE CAREFUL DO NOT DAMAGE THE HOLE
POSITION WHEN YOU USE POWER TOOLS !
NE PAS UTILISEZ DES OUTILS ÉLECTRIQUES POUR
ASSEMBLER CE PRODUIT !

STEP 1:

ÉTAPE

3		8	
16PCS		16PCS	

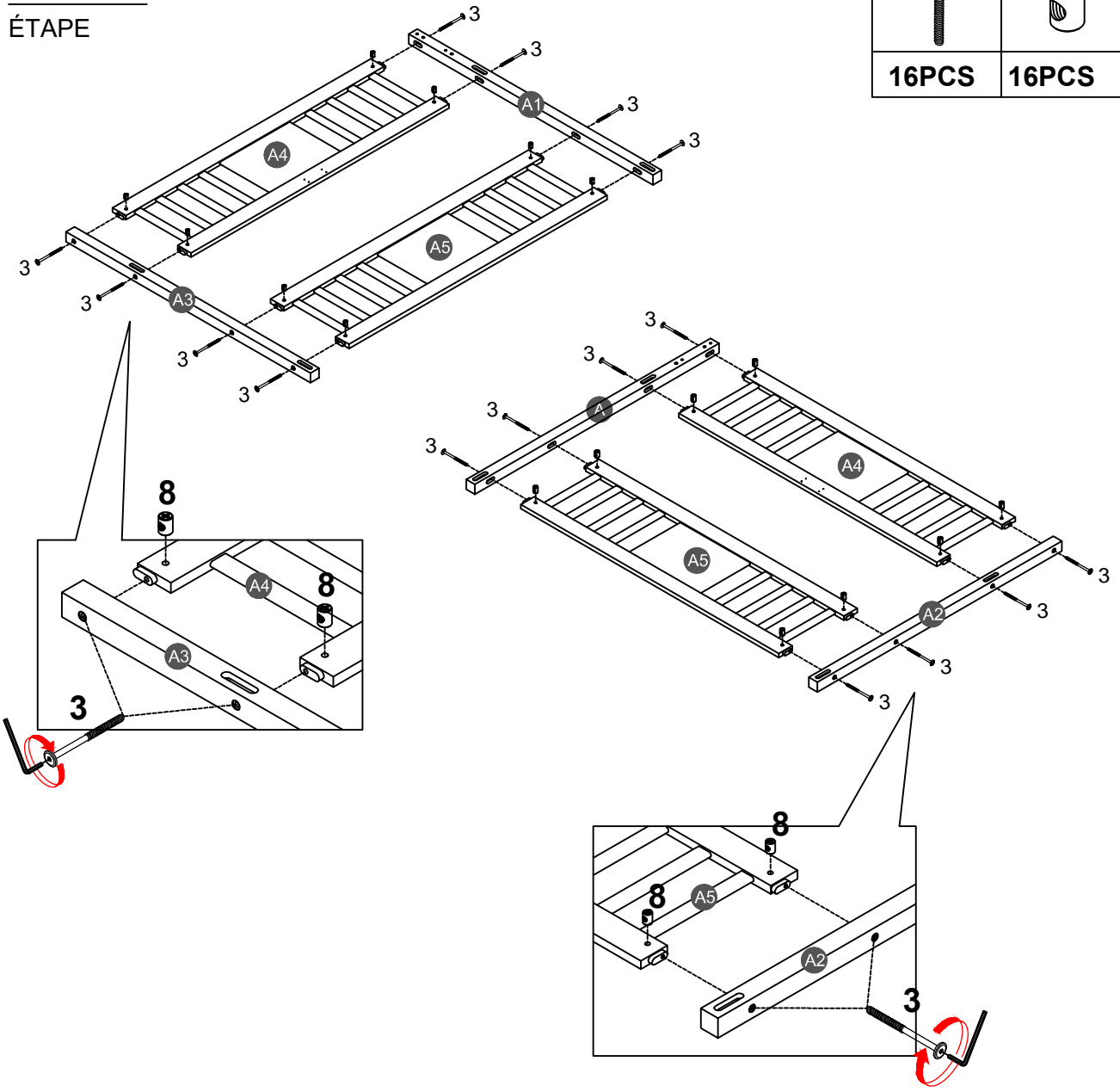

Note: Part 8 will face up with the "x" mark on it, otherwise it cannot be tightened

Remarque: La pièce 8 sera face vers le haut avec la marque "x", sinon elle ne peut pas être serrée.

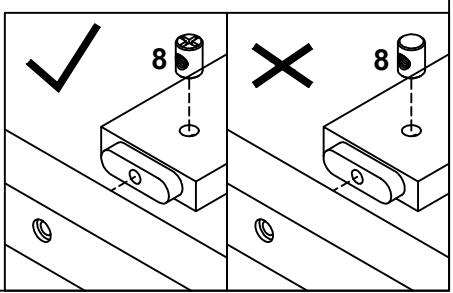

STEP 2:

ÉTAPE

9



6PCS

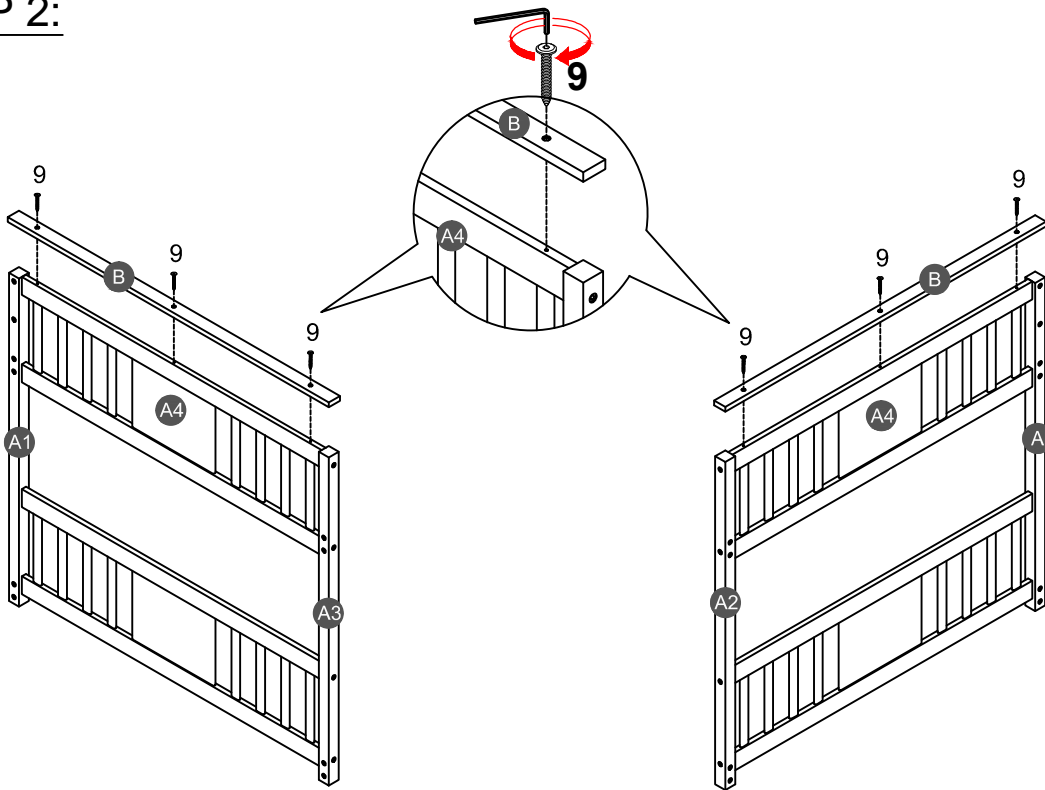

STEP 3:

ÉTAPE

12



2PCS

13



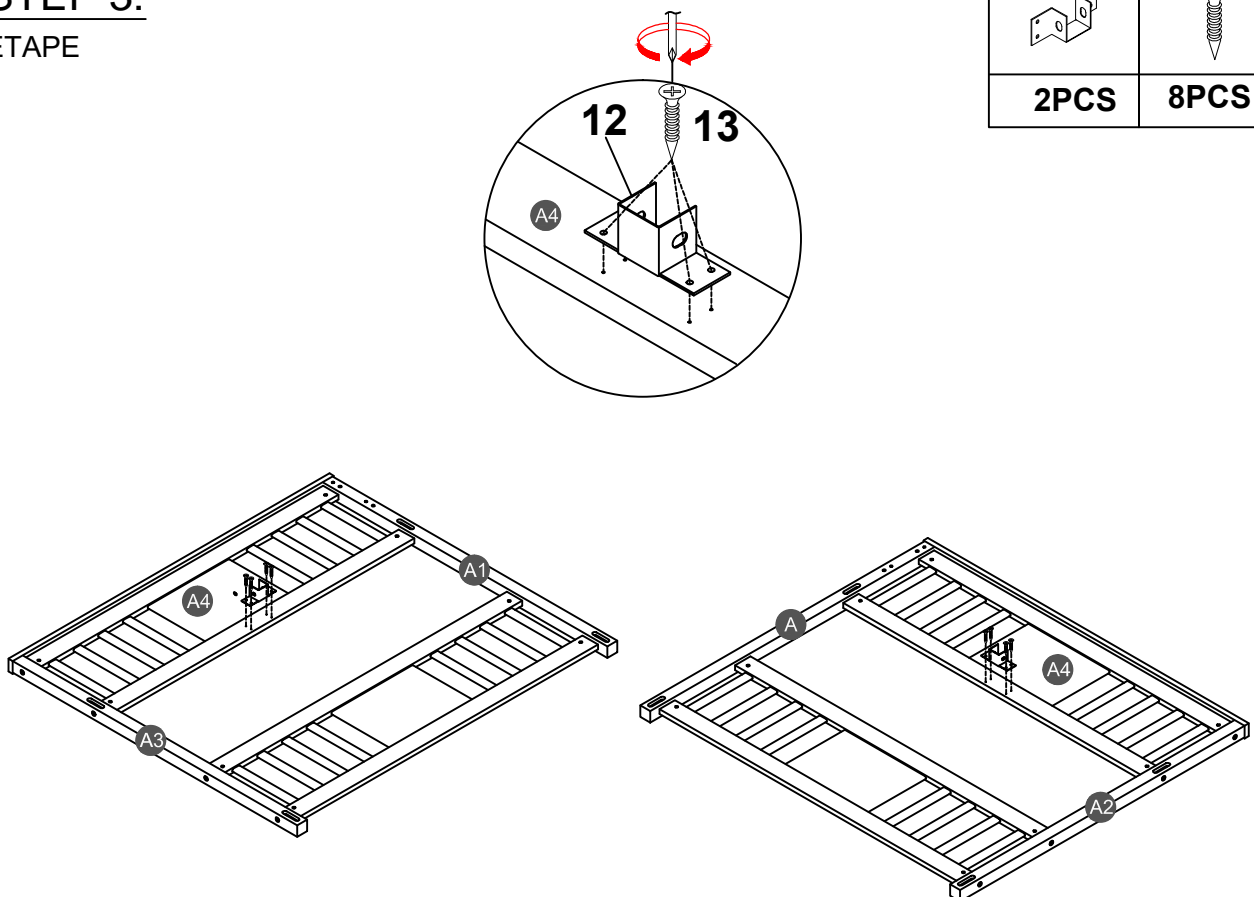

8PCS



STEP 4:

ÉTAPE

1 	2 	8 
4PCS	20PCS	20PCS

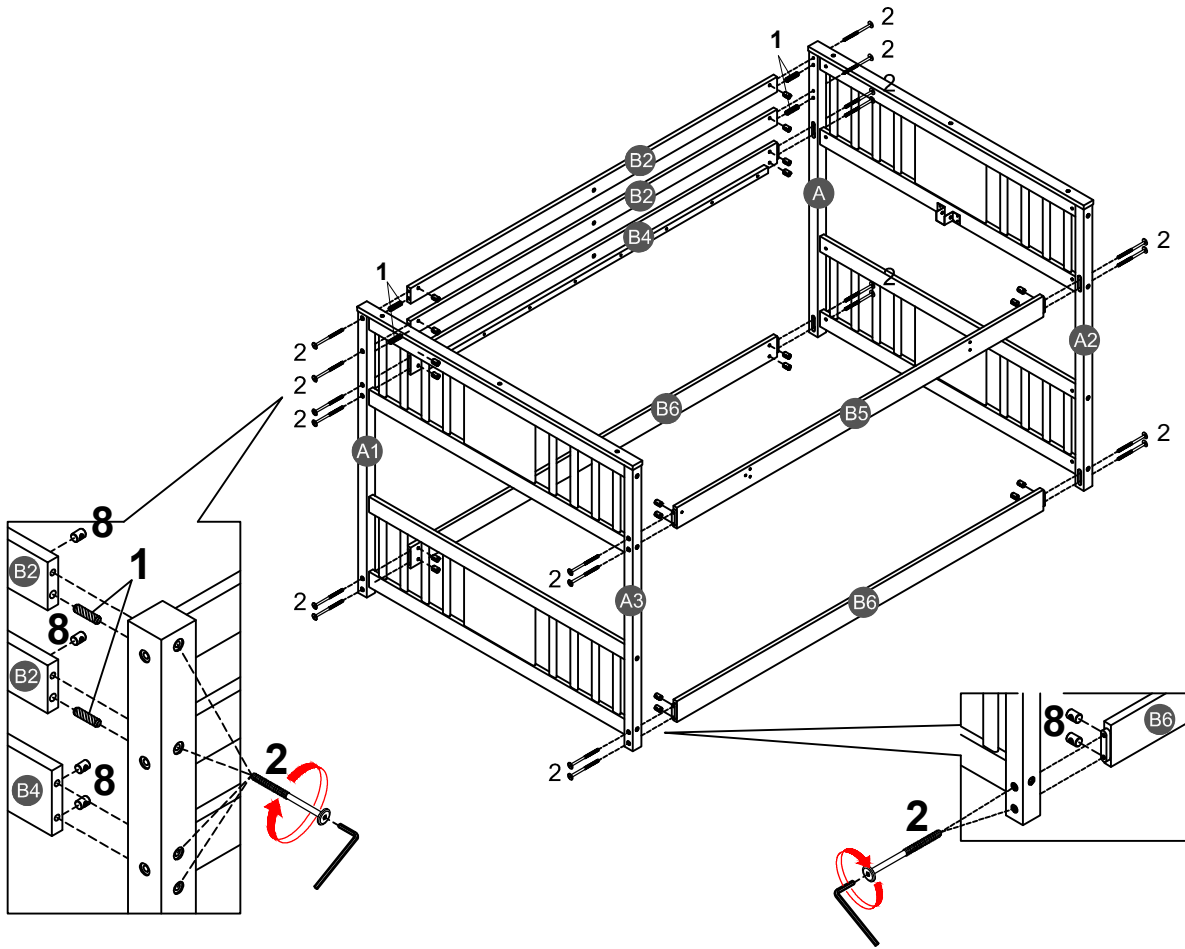

STEP 5:

ÉTAPE

7 
3PCS

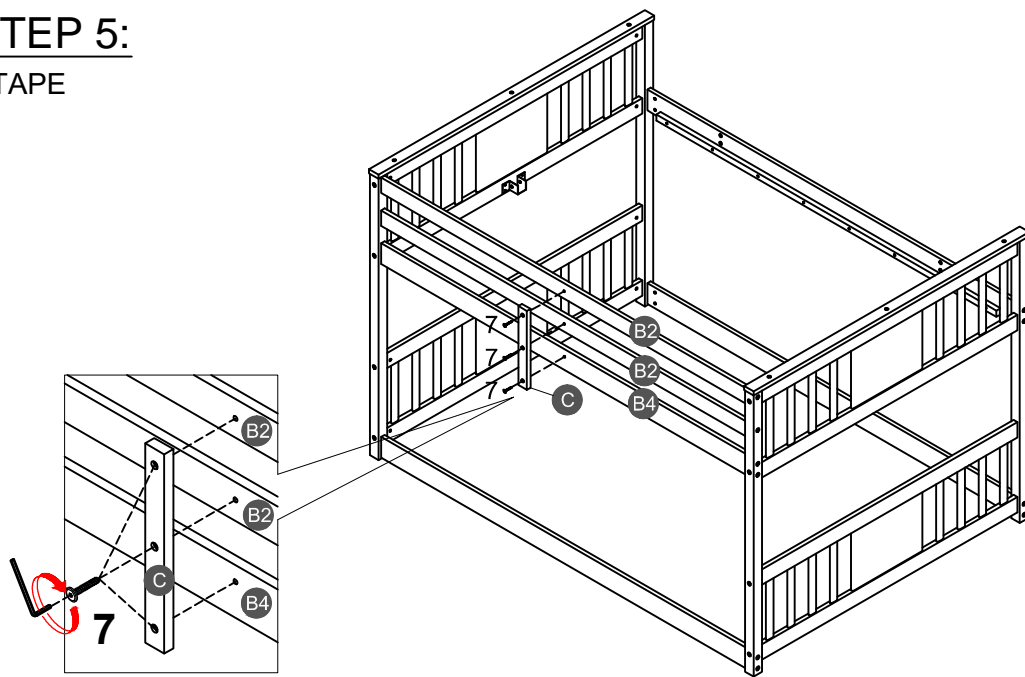

STEP 6:

ÉTAPE

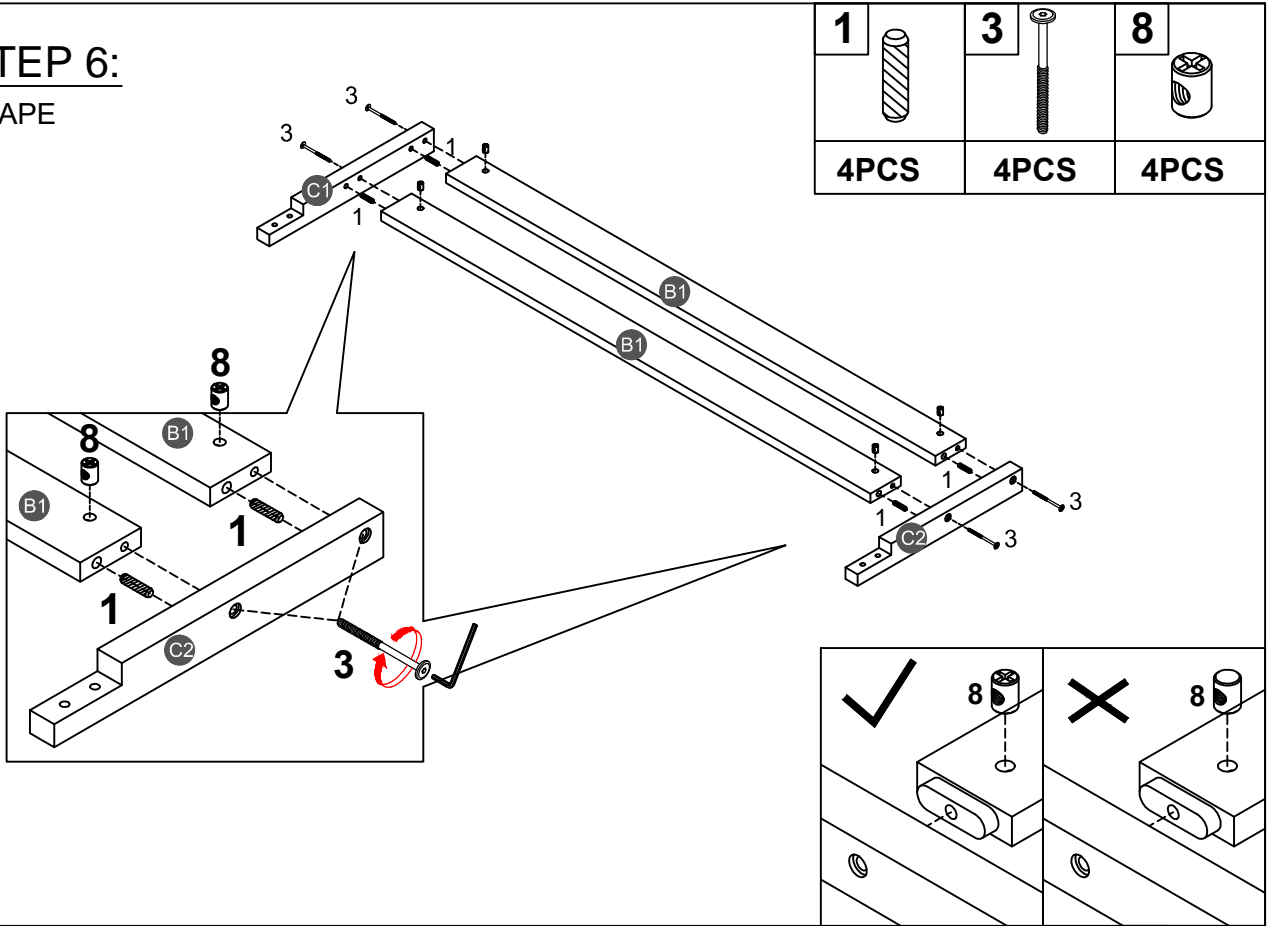

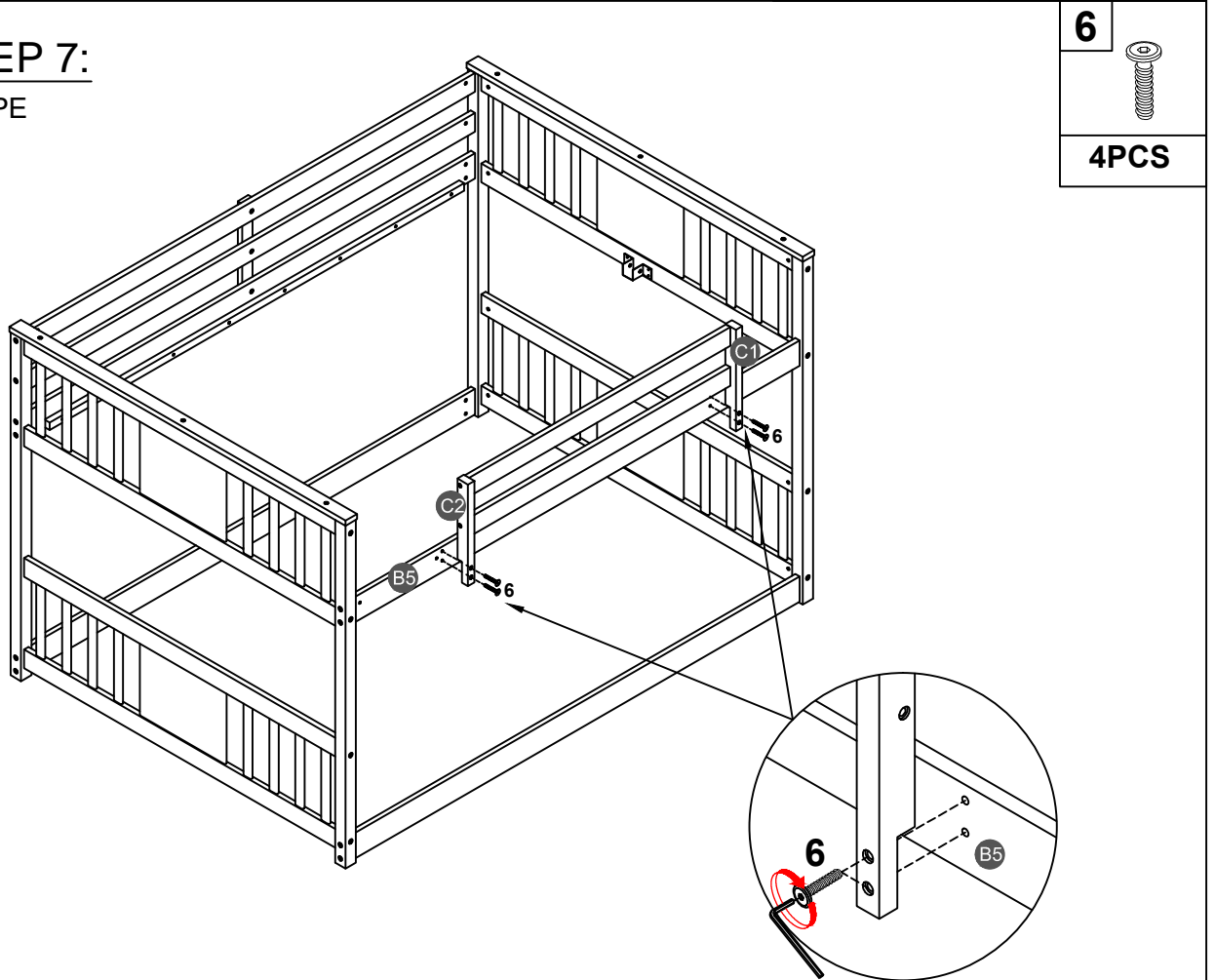

STEP 7:

ÉTAPE



STEP 8:

ÉTAPE

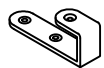
4 	8 	14 	15 
6PCS	6PCS	8PCS	4PCS

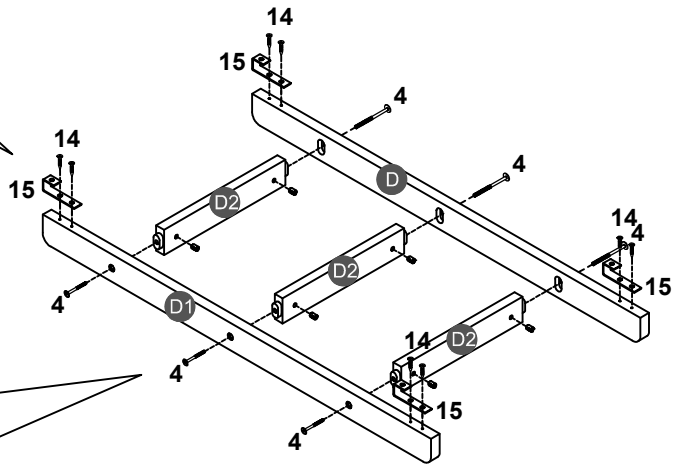
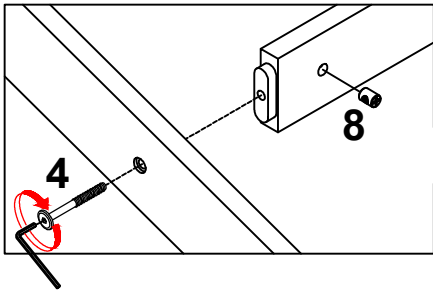
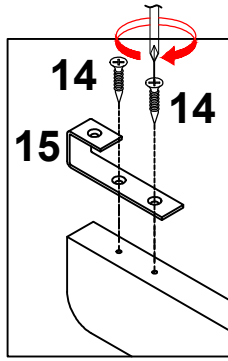

STEP 9:

ÉTAPE

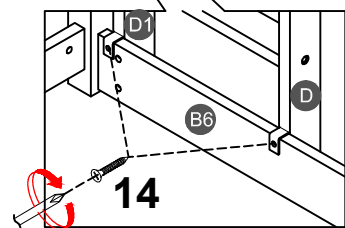
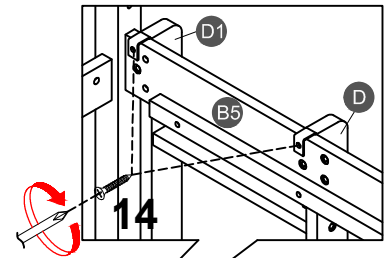
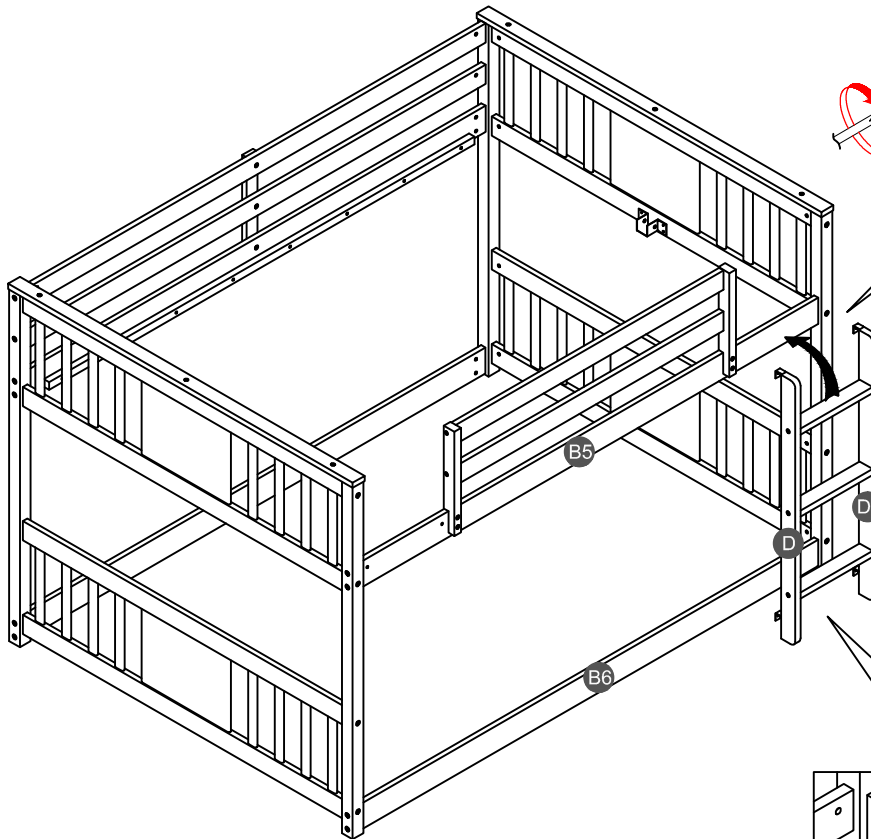



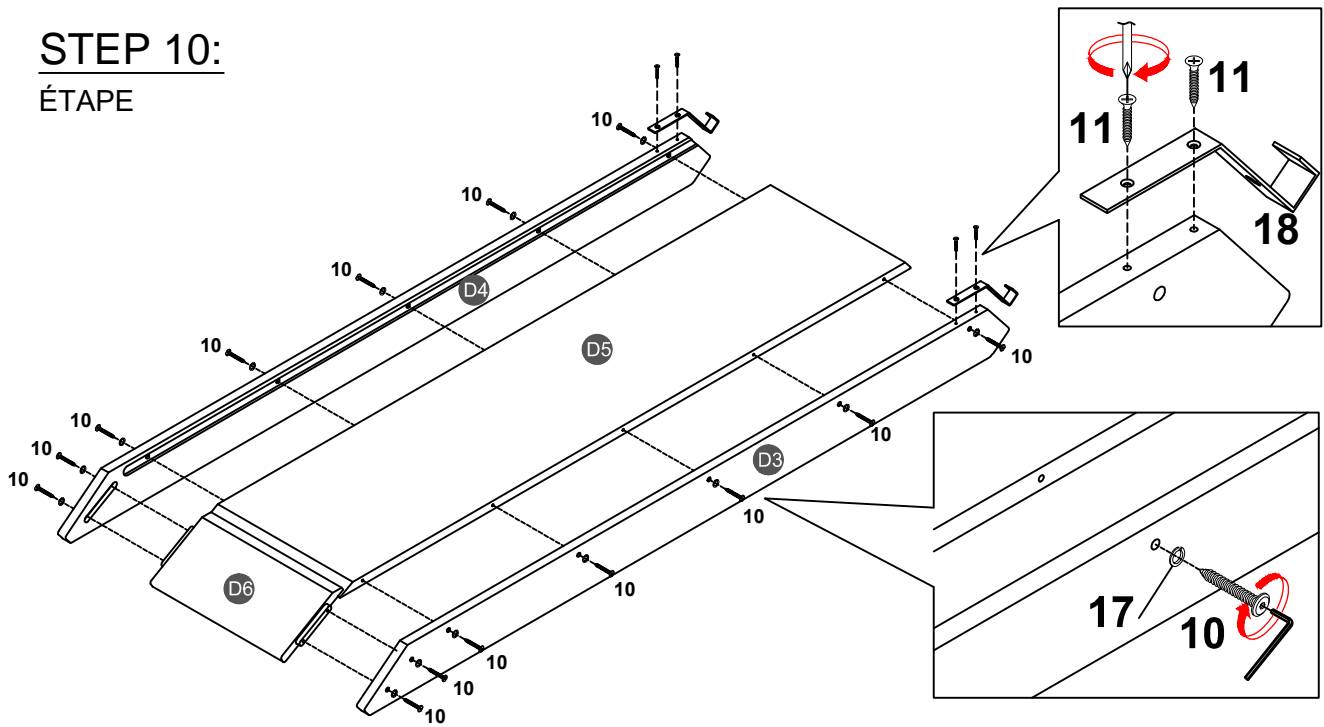

14 
4PCS

STEP 10:

ÉTAPE



10 	11 	17 	18 
14PCS	4PCS	14PCS	2PCS

STEP 11:

ÉTAPE

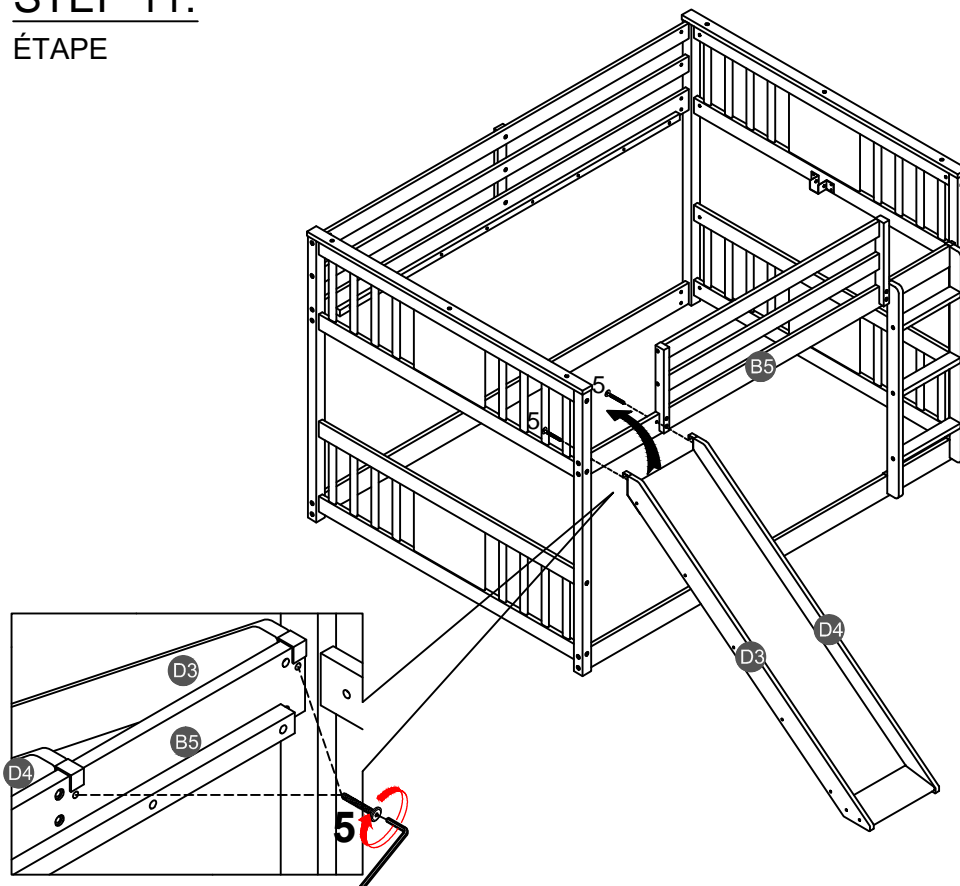



5 
2PCS

STEP 12:

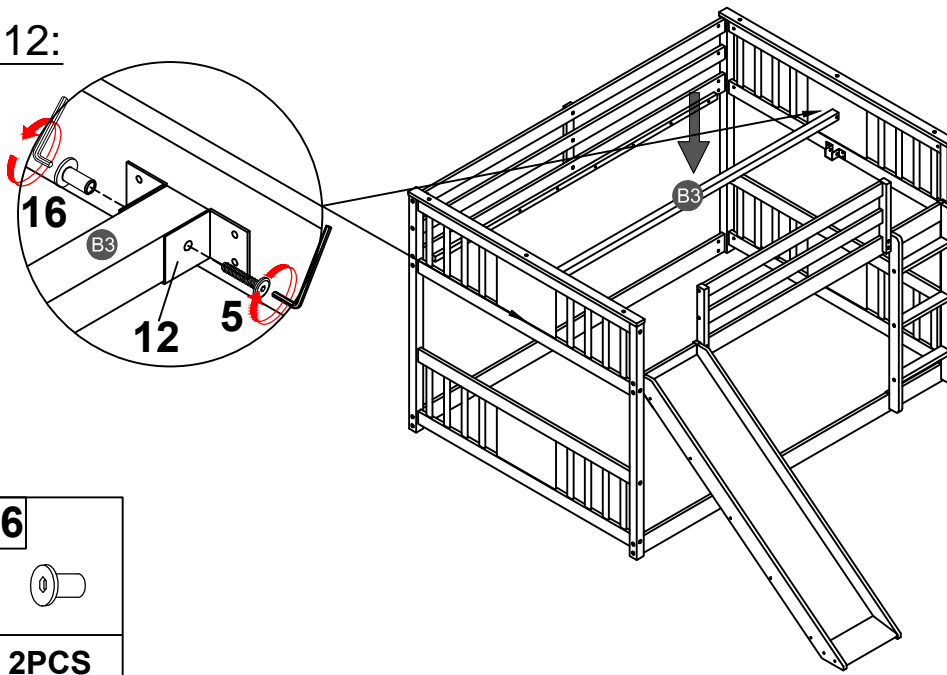
ÉTAPE



5		16	
2PCS		2PCS	

STEP 13:

ÉTAPE

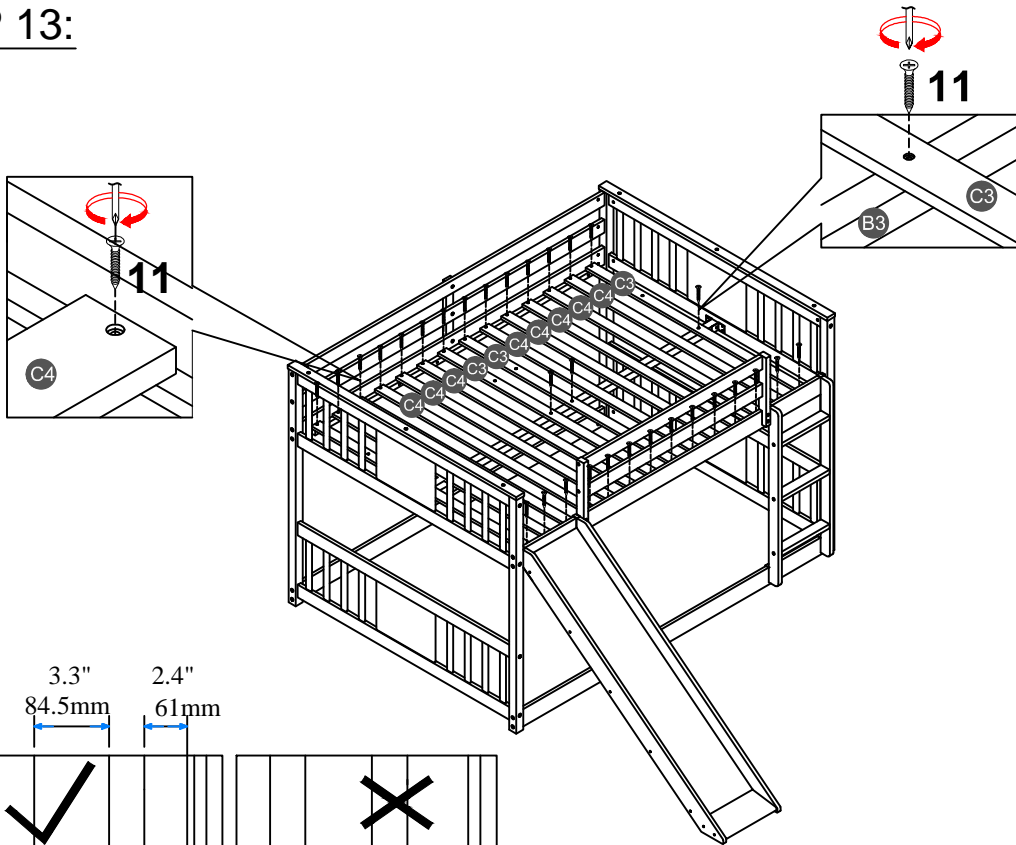

11	
32PCS	

NOTE: Please make sure the bed slats close to the side rail before locking the screws to avoid breakage. This step is required for both the left and right sides. Moreover, please do not lock the screws of the bed slats at the outermost edge to avoid damaging.

Remarque: Assurez-vous Les lattes du lit fermer du rail latéral avant de verrouiller les vis pour éviter la casse. Cette étape est requise pour tous les deux côtés gauche et droit. De plus, ne verrouillez pas les vis des lattes de lit sur le bord le plus extérieur pour éviter d'endommager.

Make sure to tighten all the screws of the bed.

Assurez-vous de serrer toutes les vis des de lit.