

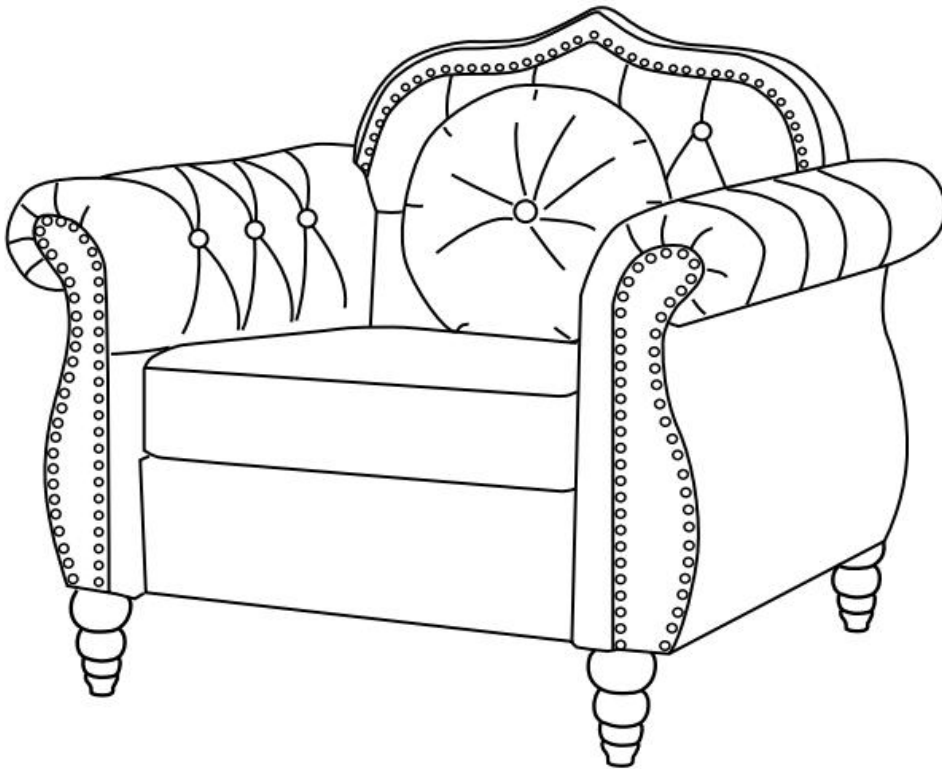



# Assembly Instructions

**Note: Please help to read my instruction before you ready to assemble.**



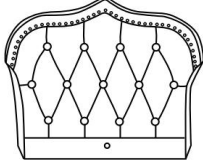
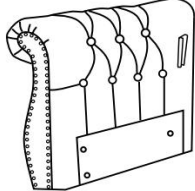
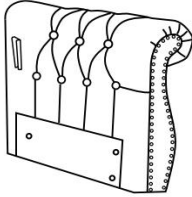
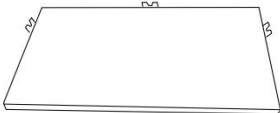
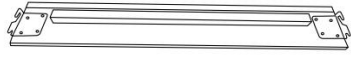
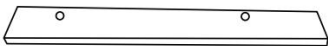

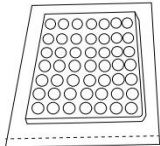
## Chair









## Part List

Label	Picture	Description	QTY (PCS)
A		Backrest	1
B		Left Armrest	1
C		Right Armrest	1
D		Seat	1
E		Front Rail	1
F		Back Panel	1
G		Seat Cushion (Fabric Cover)	1
H		Compressed Seat Spring Package	1
I		Pillow	1
J		Leg	4

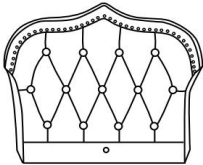
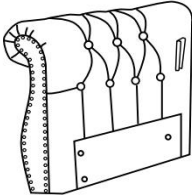
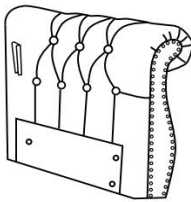
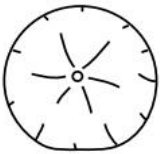
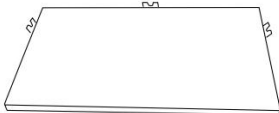
## Hardware

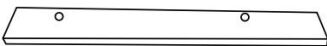
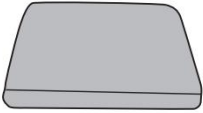
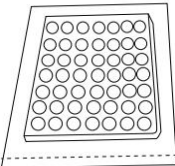
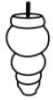
①		Plastic Washer	7
②		Allen Wrench	1
③		Bolt(M8*40mm)	3
④		Flat Washer	3

## Assembly Preparation

All Including:					
					
					
	x4	x1	x7	x3	x3

### **NOTICE:**

- Please read the instruction from cover to cover in detail.Thanks.
- Installed by at least two adults
- To avoid damaging your furniture , Please don't assemble on flooring or carpet.
- Please assemble on a clean non-marring surface, example for packing foam.
- Saving all packaging until have finished.

## Assembly Steps

### OVERVIEW

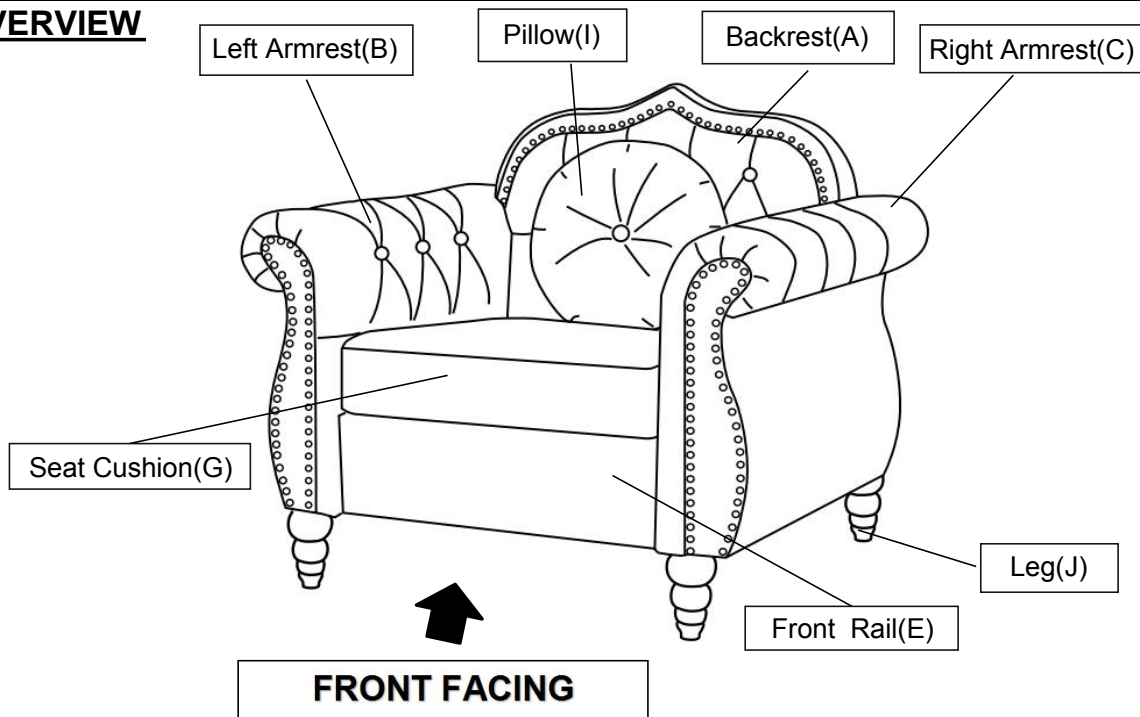

This Chair has multiple parts and may require up to 30 minutes to assemble. To give you an overview of the Chair parts, the above picture is to help you put the various parts into perspective. Please read through the instructions below to familiarise yourself with the parts and steps before assembly.

**Note: It is recommended that you have an adult partner to assist during the entire assembly process.**

### Step 1

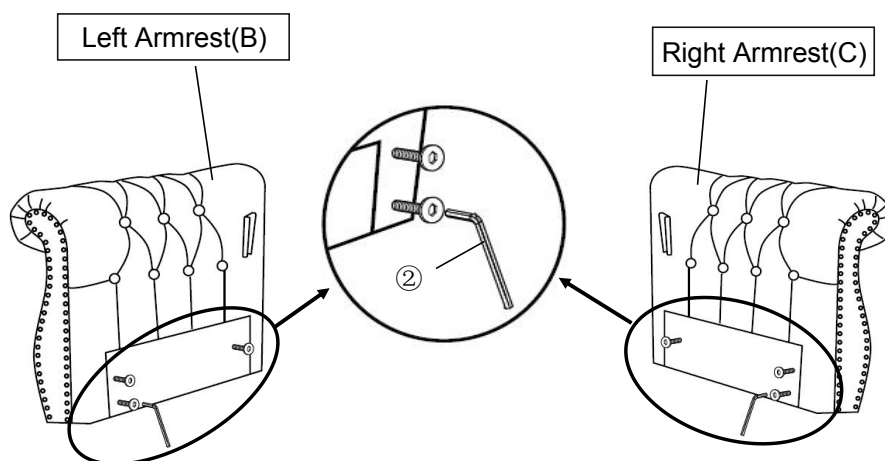

Open the carton and place all the parts on a clean, non-marring surface.

Loosen the 3 bolts in Left Armrest(B) and Right Armrest(C) around half inch by Allen Wrench(2).

**Step 2**

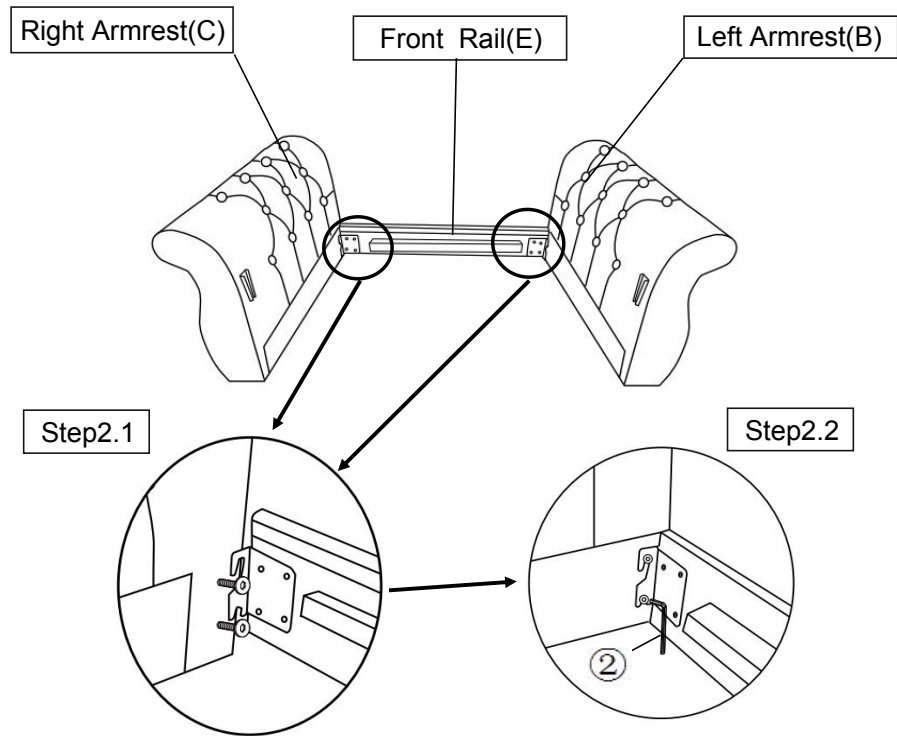

Step2.1 Slide the hook in the end of Front Rail(E) into the bolts on the Left Armrest(B) and Right Armrest(C) as shown in Picture.

Step2.2 Tighten the Bolts by Allen Wrench(②).

**Step 3**

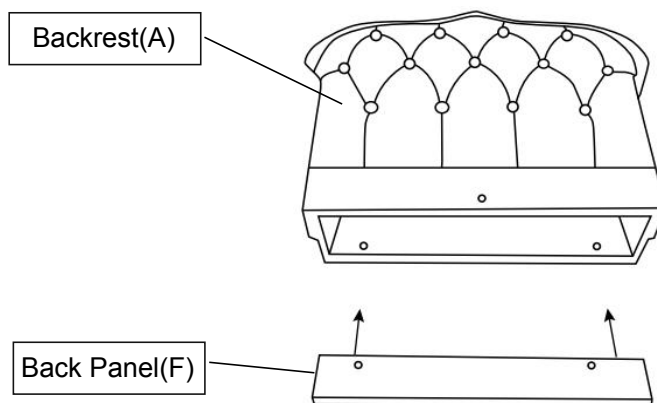

Put the Back Panel(F) under Backrest(A).

**Step 4**

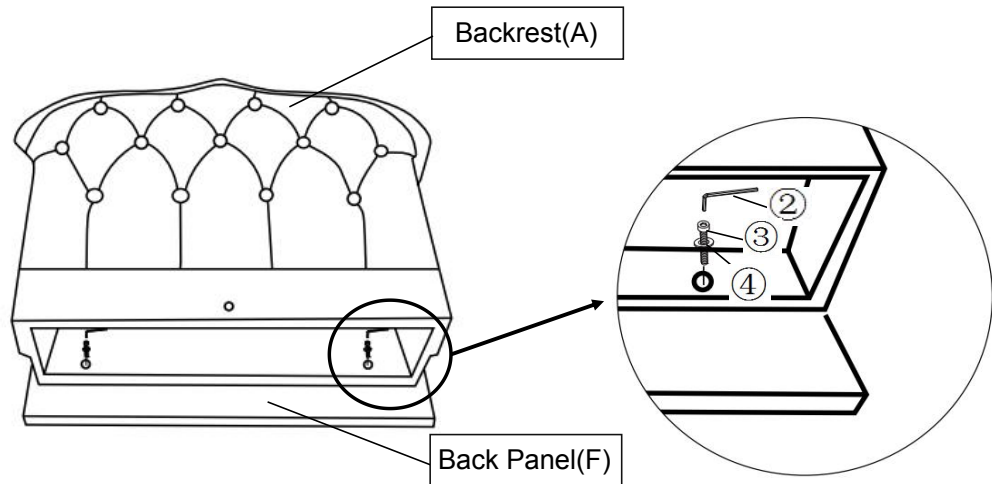

Using Bolt(③), Flat Washer(④) with Allen Wrench(②) turning clockwise until tight.

**Step 5**

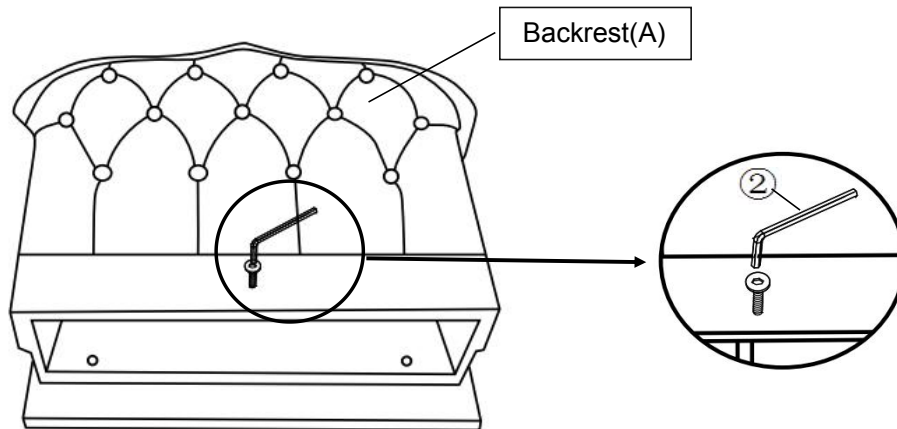

Loosen one bolt in Backrest(A) around half inch by Allen Wrench(②).

### Step 6

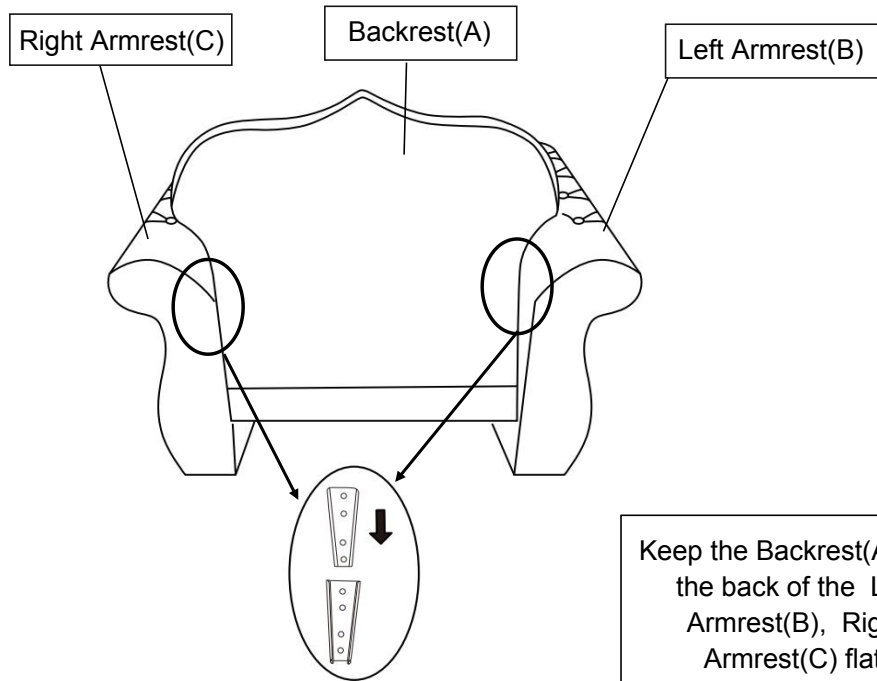

Slide the Tapered Connectors on the Backrest(A) into the Tapered Connectors on the Left Armrest(B) and Right Armrest(C) as shown in the picture.

**Note: Make sure the Tapered Connectors on Backrest(A) lock into the Tapered Connectors on the Left Armrest(B) and Right Armrest(C).**

**Assistance from an adult partner is necessary for this assembly process.**

**During this assembly process - do exercise caution. You may need to use your hand to press down and or pave away the padded surface to facilitate the 'slip and slide' assembly.**

**Caution: Ensure that your fingers do not get caught or pinched in the assembly process.**

### Step 7

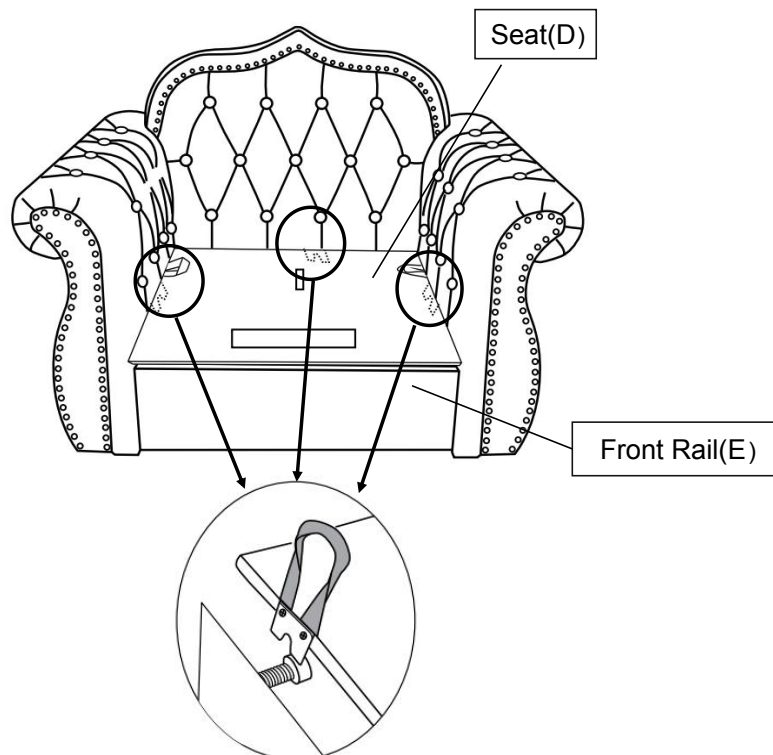

Lift the rope on the two sides of Seat(D) by hand.

Put the Seat(D) on the wood bar of the Front Rail(E) and then slowly place it down as shown above.

**Note: All the u-shaped iron sheet need clamped to the bolt.**

**Step 8**

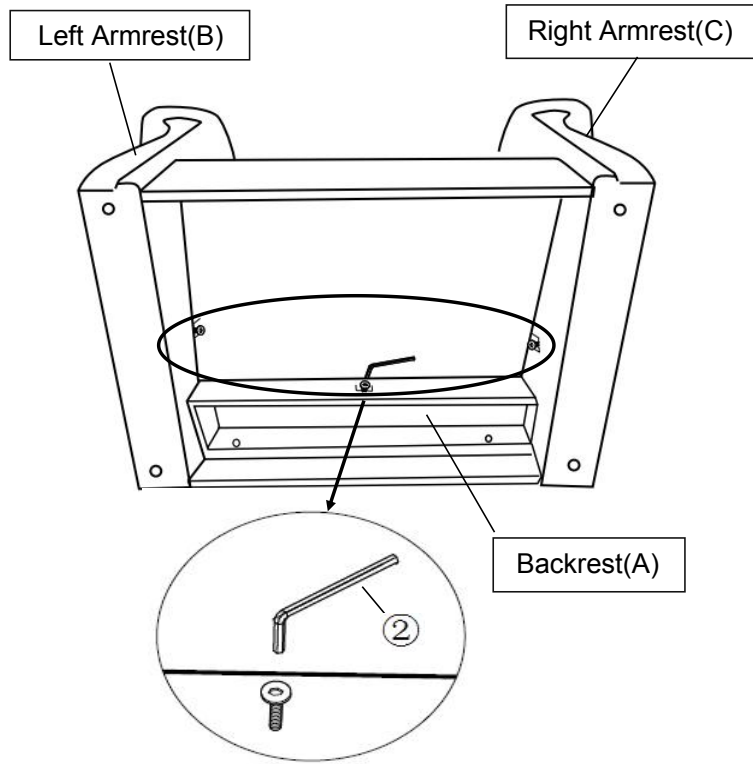

Tilt and lay the Chair onto a flat surface.  
Tighten the Bolts in the bottom of Backrest(A), Left Armrest(B) and Right Armrest(C) by Allen Wrench(②) as pictured above.  
Tighten the Bolts fully in a sequential manner.

**Step 9**

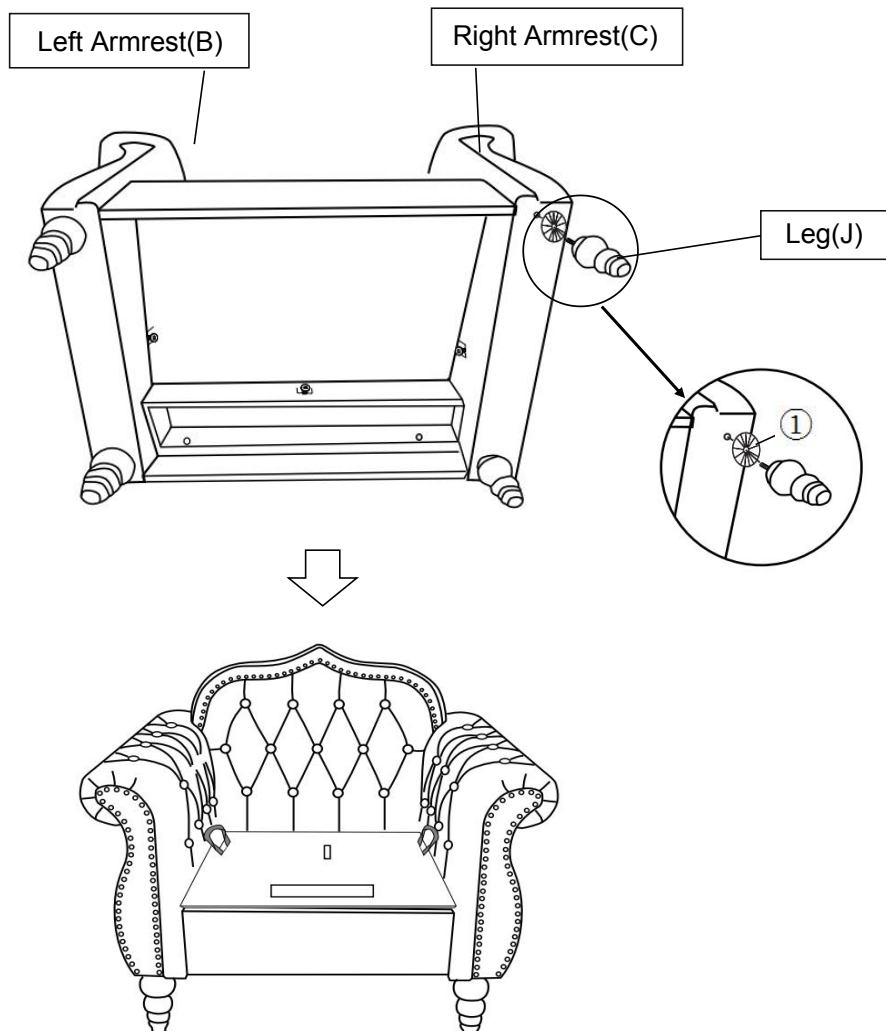

Install the Leg(J) at the bottom of Left Armrest (B) and Right Armrest(C) by placing one Plastic Washer(①) on the threaded stem.

Then insert threaded stem into the threaded mounting position at the bottom of Left Armrest(B) and Right Armrest(C). Tighten by turning the Leg clockwise and position right side up.

**Note: The use of Plastic Washer(①) are OPTIONAL and are especially useful to help alleviate slight wobbles. Some Legs may need more than one whilst some legs may not need any.**

### Step 10

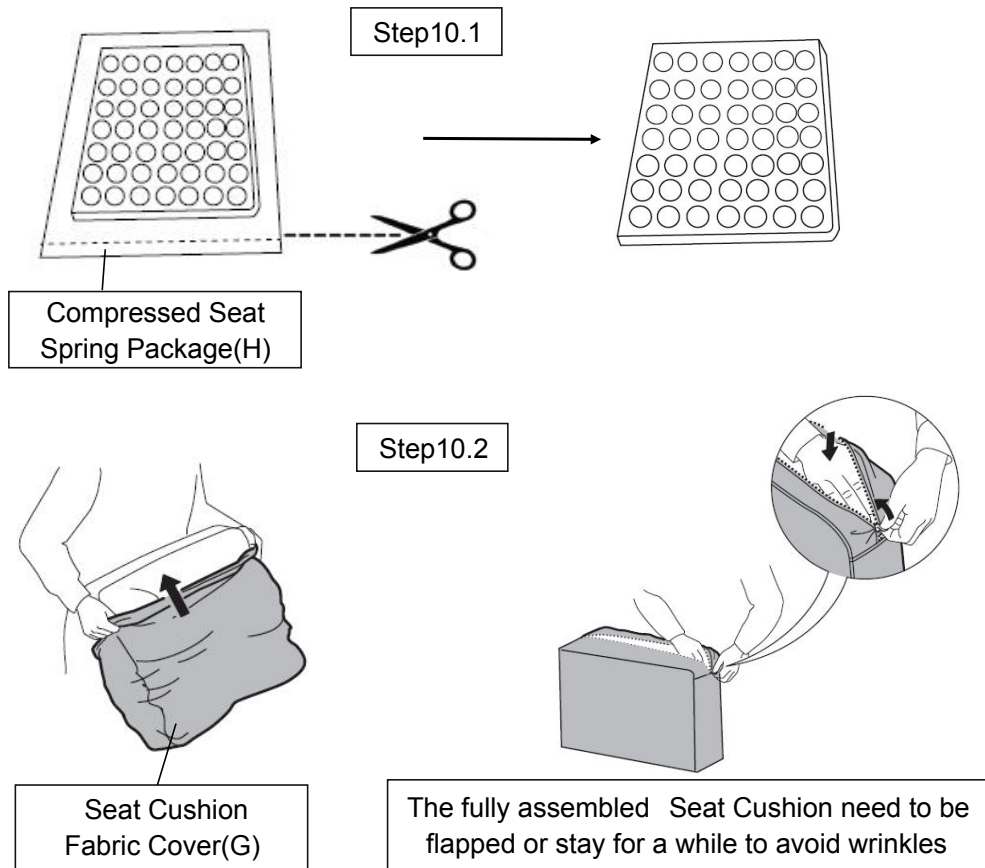

Step 10.1 Cut and remove the Compressed Seat Spring Package(H).

Step 10.2 Put the Seat Spring Package(H) into the Seat Cushion Fabric Cover(G) as picture showed.

### Step 11

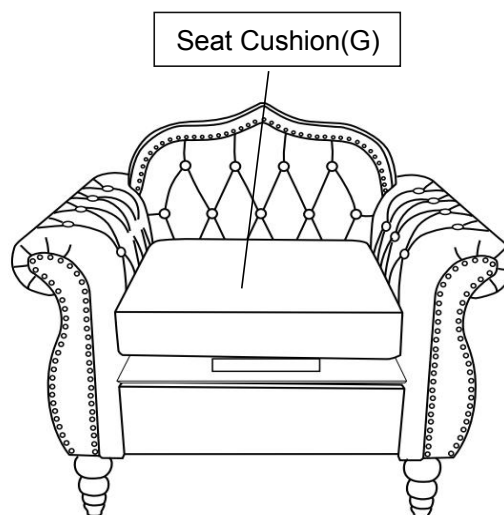

Put the Seat Cushion(G) on the Chair.

Step 12

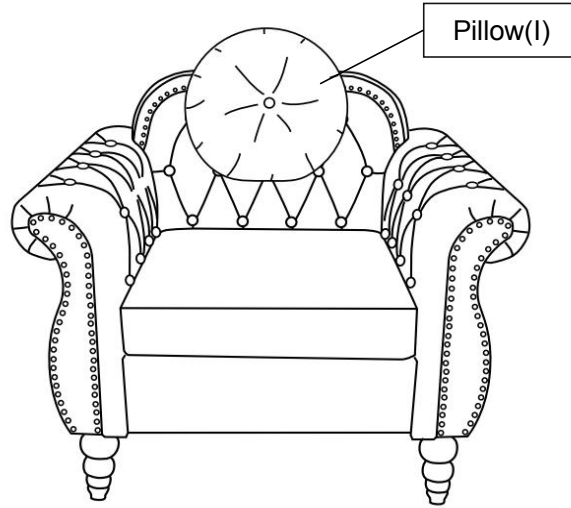

Put the Pillow(I) on the Chair.

Step 13

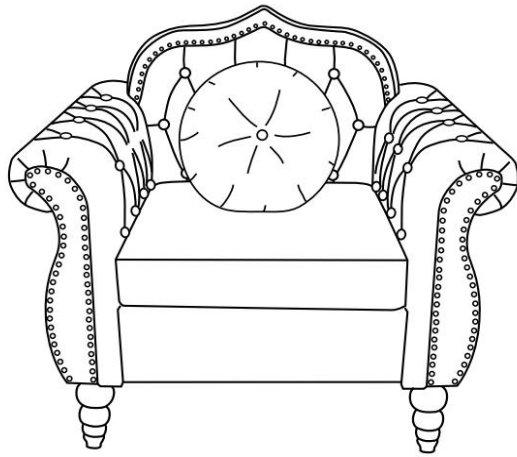

Your Chair is ready for use.  
This Chair can only be used on a flat, level surface.