

THIS INSTRUCTION BOOKLET CONTAINS IMPORTANT INFORMATION. PLEASE READ AND KEEP FOR FUTURE REFERENCE

**We stand behind we sell. If you are not satisfied with your purchase
Please don't hesitate to contact us.**

Email: umservice001@outlook.com

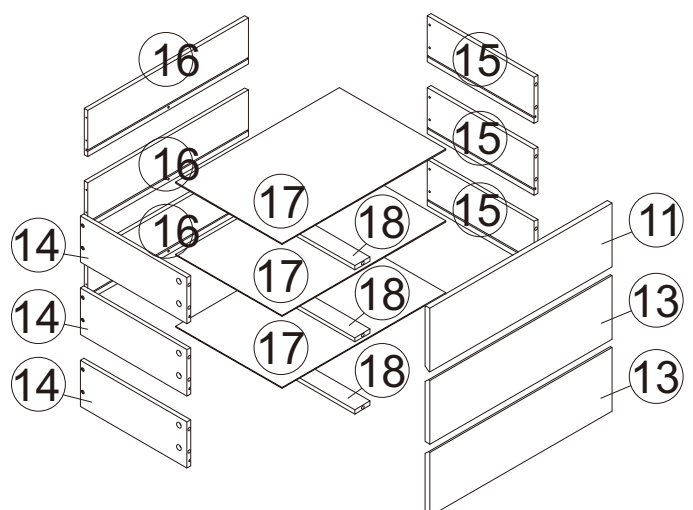

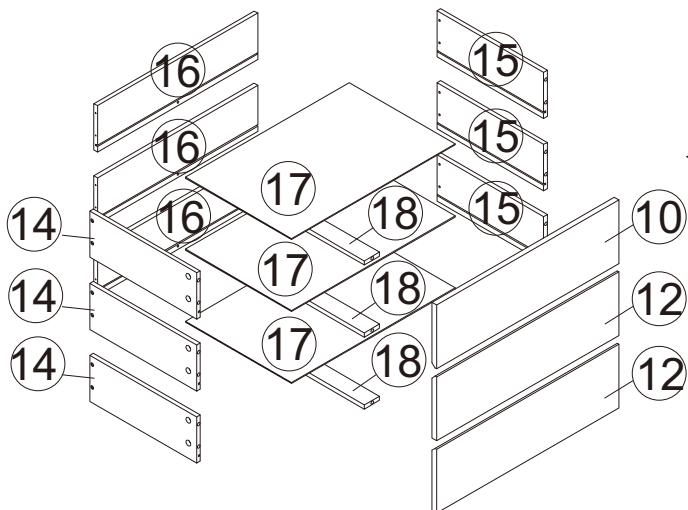
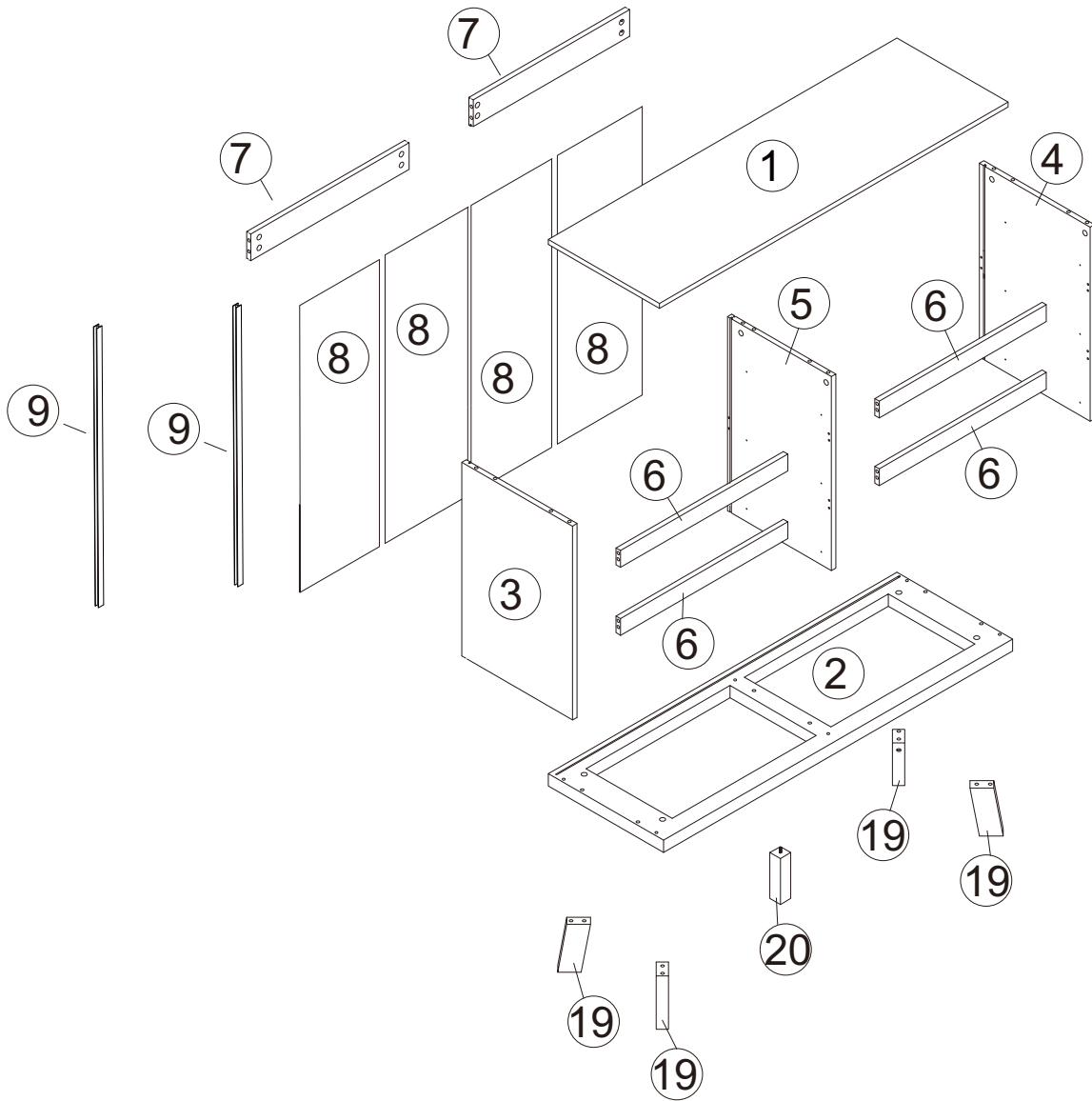

Fittings

Please check that you have all the fittings listed below:

NOTE: The quantities below are the correct amount to complete the assembly. In some cases more fittings may be supplied than required.

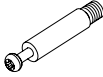
Bag 1

 Ax52	 Bx52	 Cx20	 Dx2
 Ex4	 Fx32	 Gx48	 Hx4
 Ix2	 Jx4	 Kx6	 Lx2
 Mx2	 Ox8	 Px8	 Qx5
 CLx6	 CRx6	 DLx6	 DRx6

Tools required

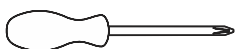

Phillips screwdriver
(small & medium)



Flathead screwdriver
(small & medium)

Step 1

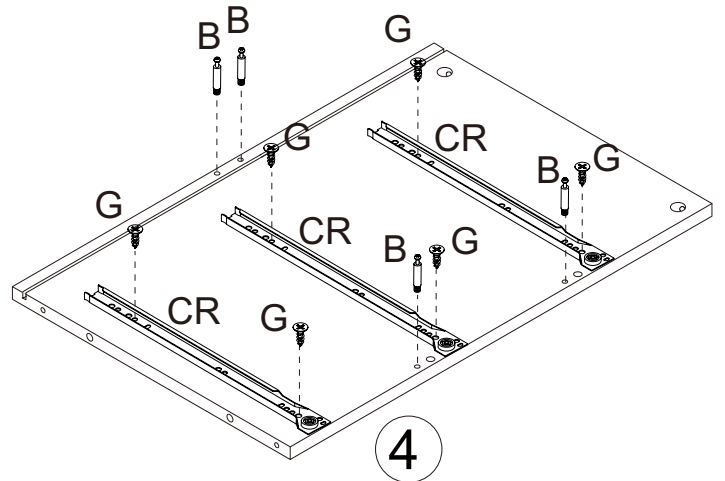
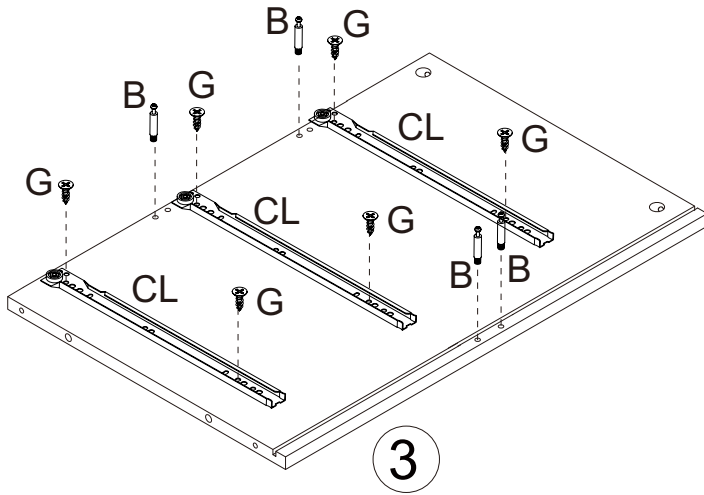
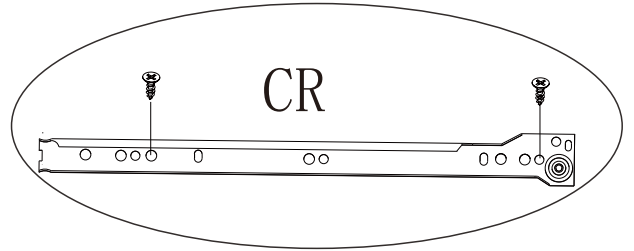
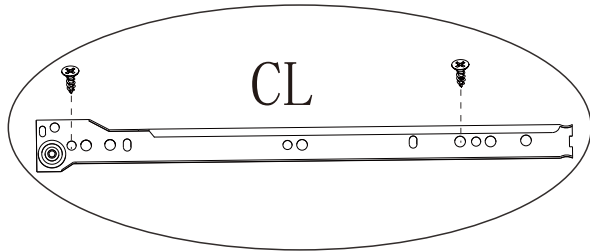

Bx8



Gx12



CLx3



CRx3



Step 2

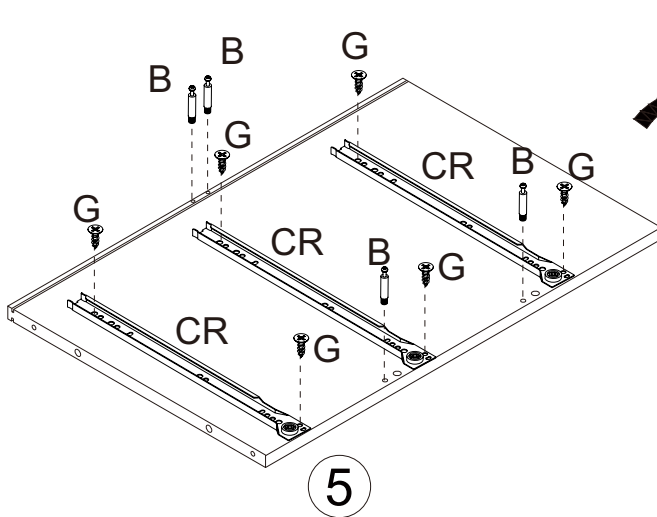
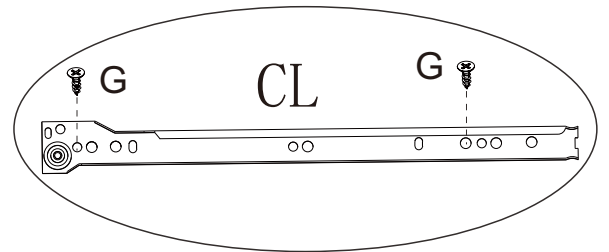
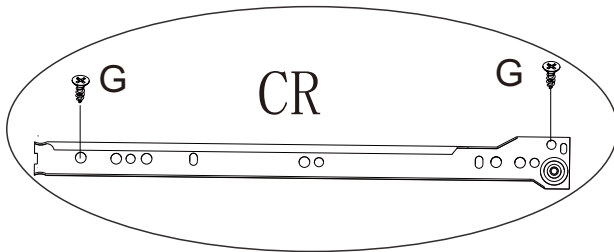

FLIP

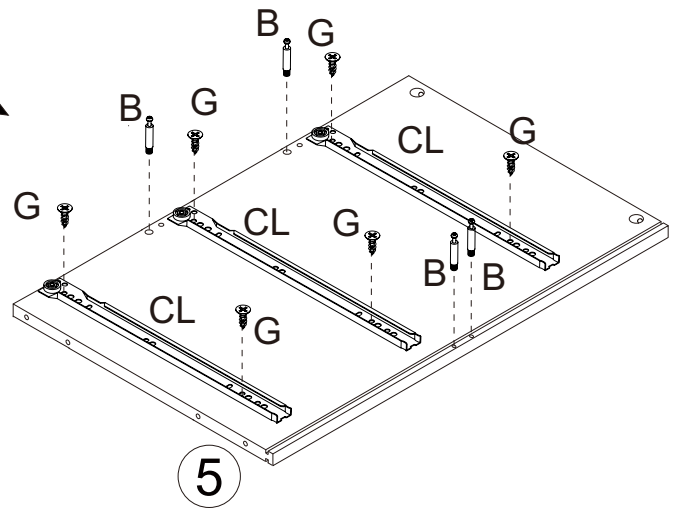

Bx8



Gx12



CLx3



CRx3

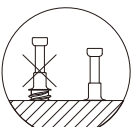

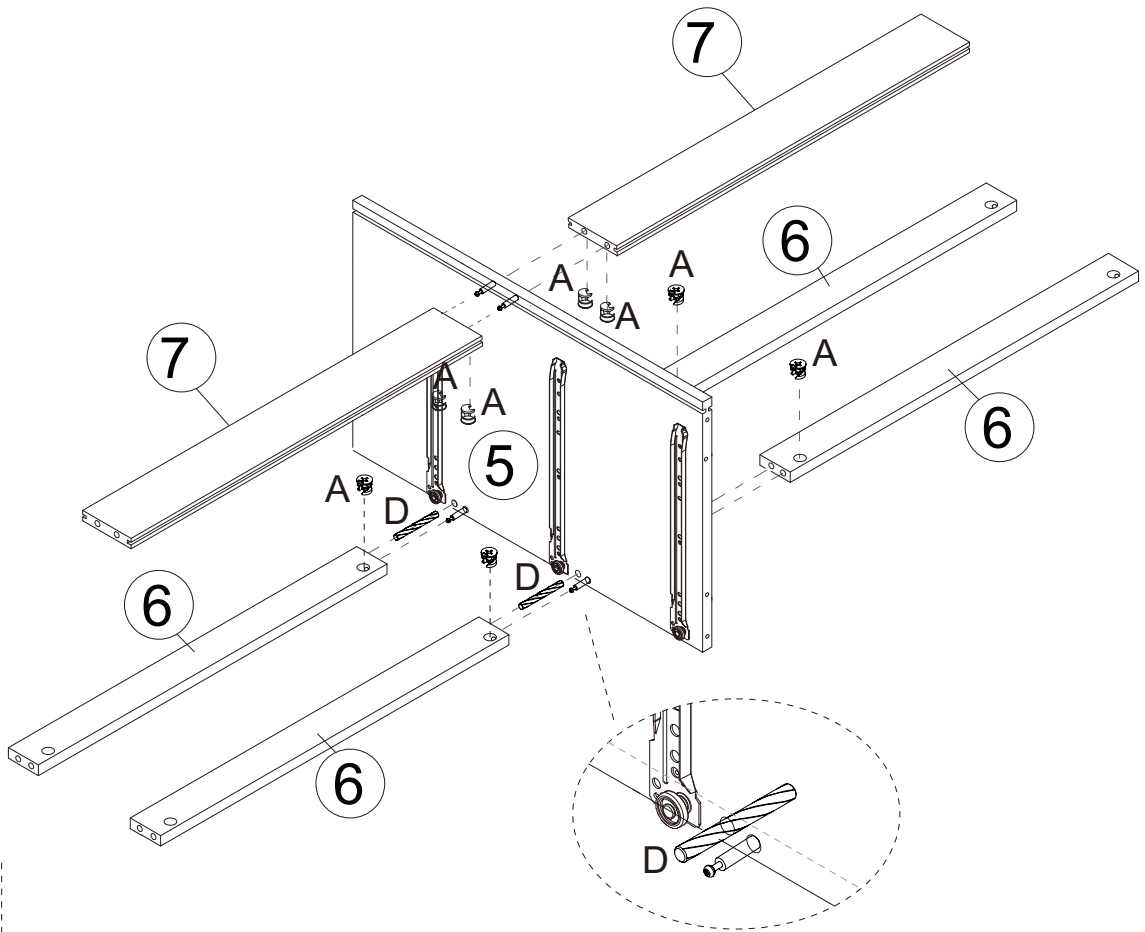

Step 3

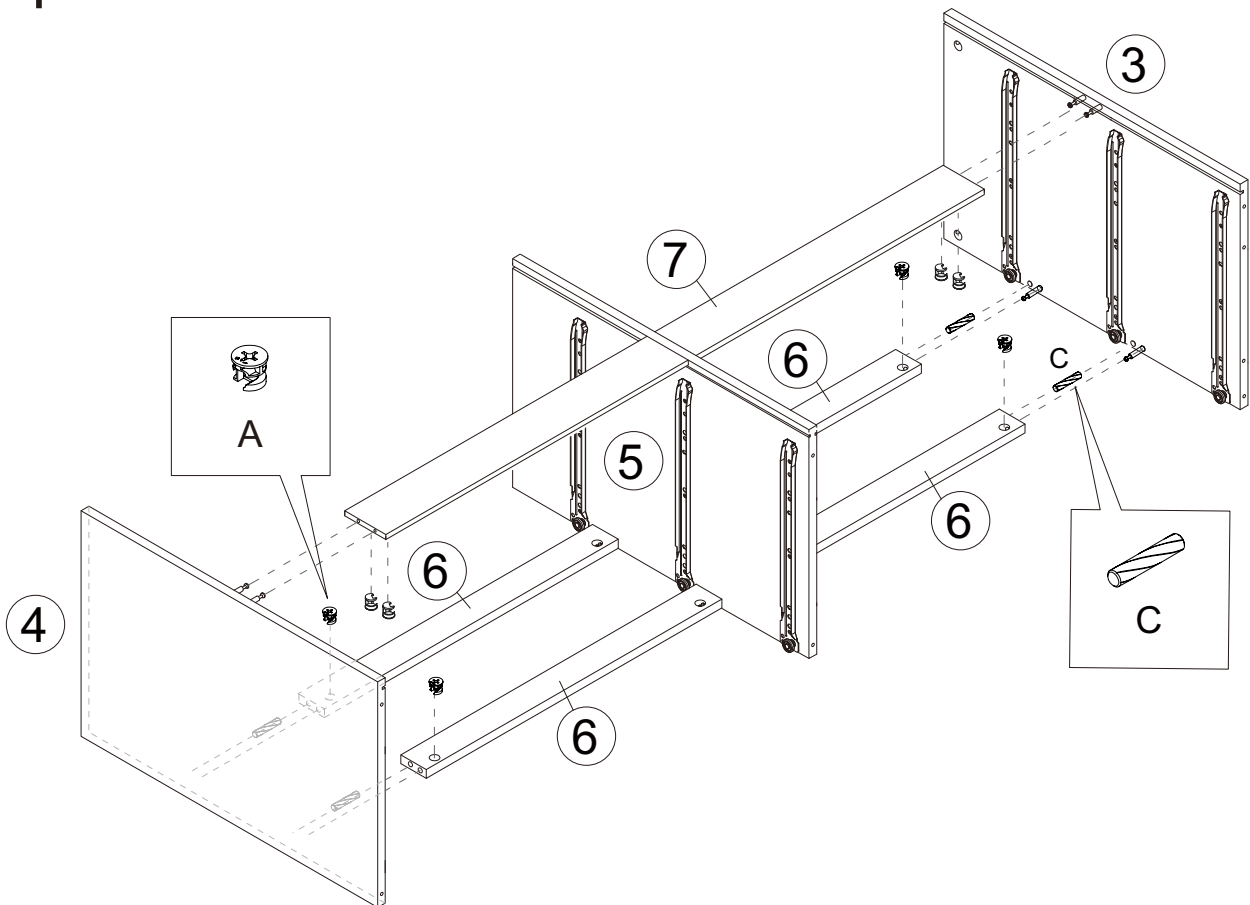

- | | |
|--|-----|
|  | Ax8 |
|  | Dx2 |

Step 4



- | | |
|--|-----|
|  | Ax8 |
|  | Cx4 |

Step 5

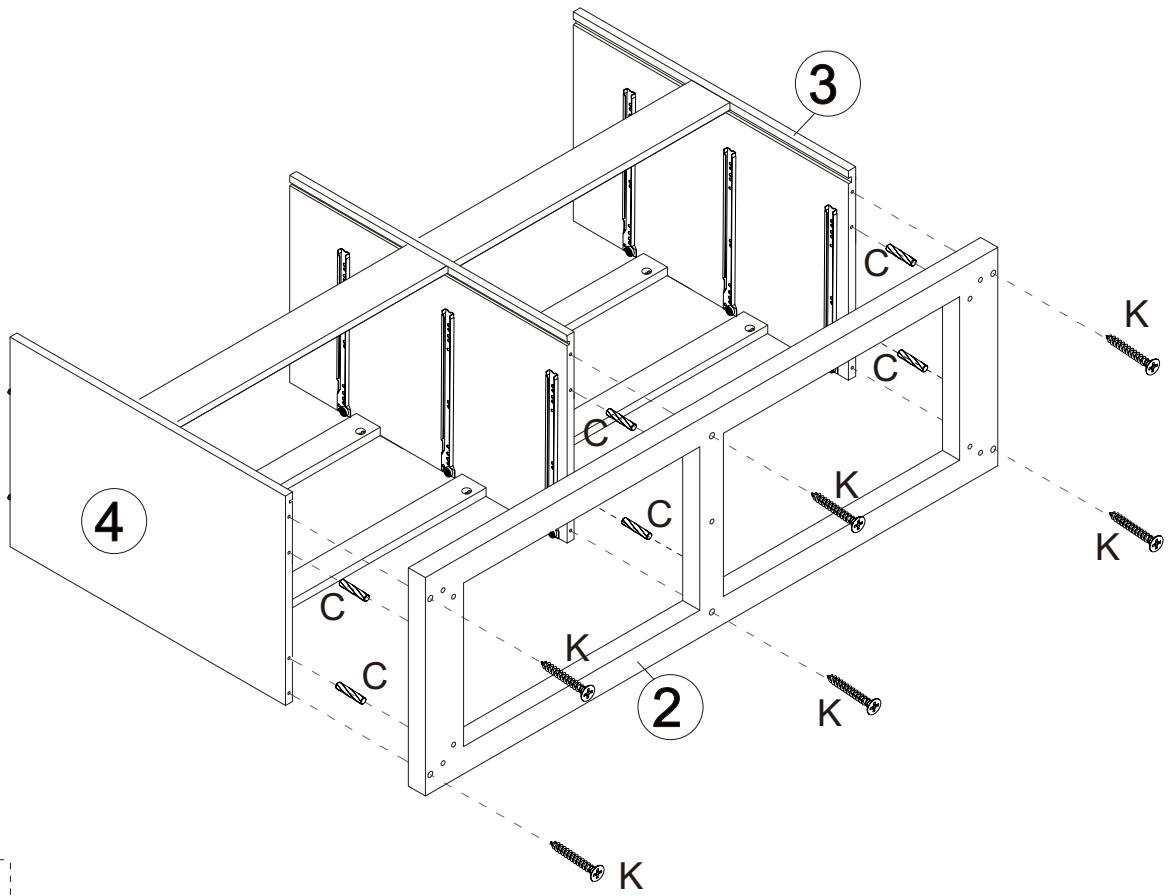



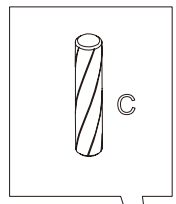
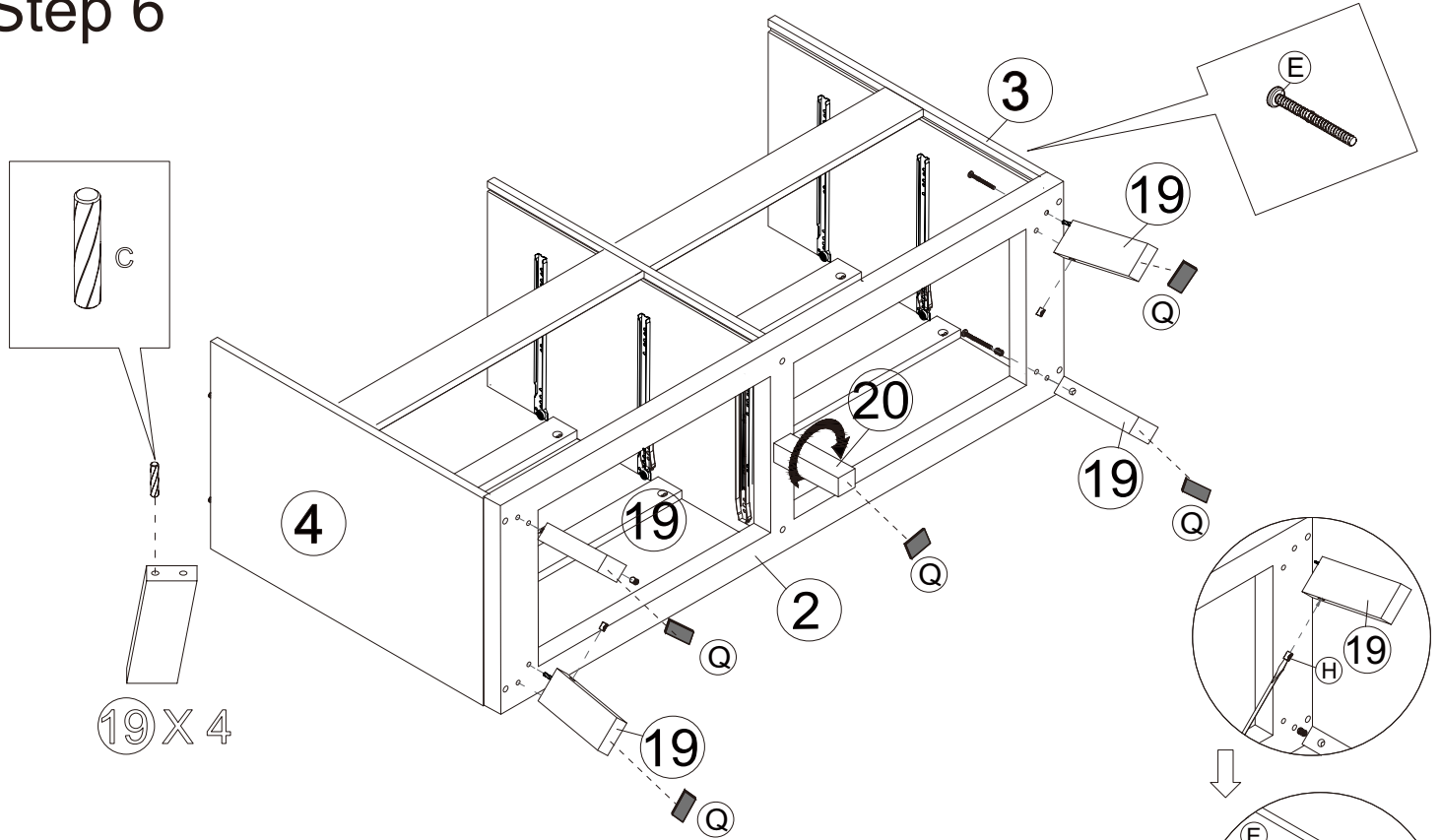

-  Cx6
-  Kx6

Step 6



19 X 4

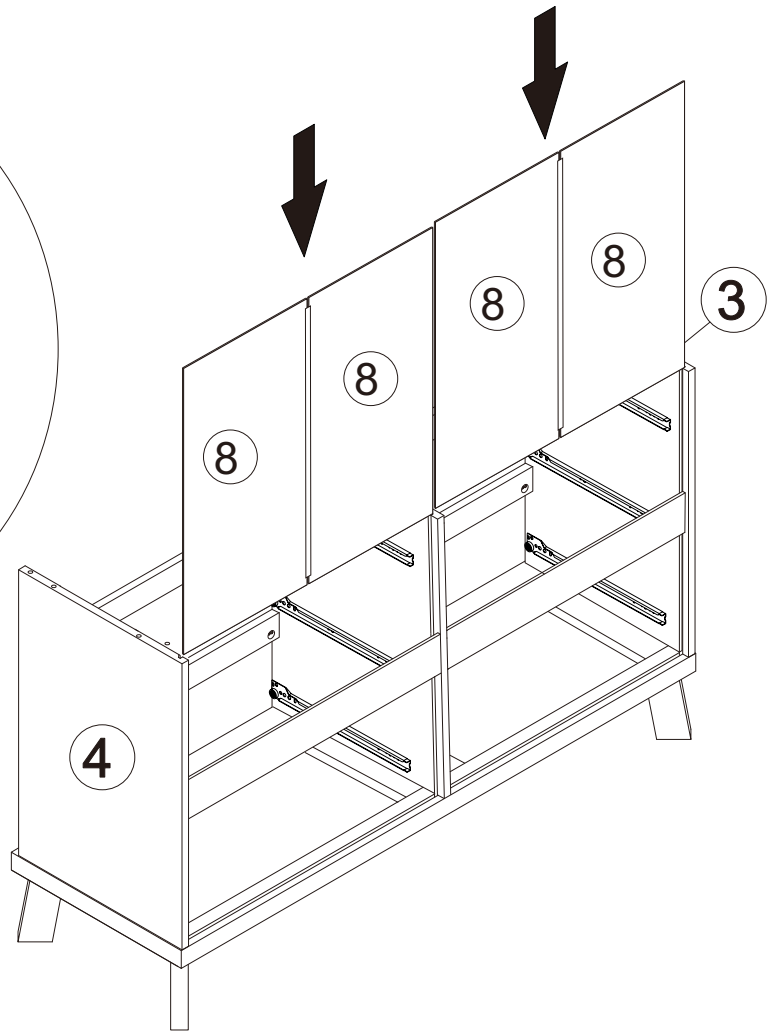
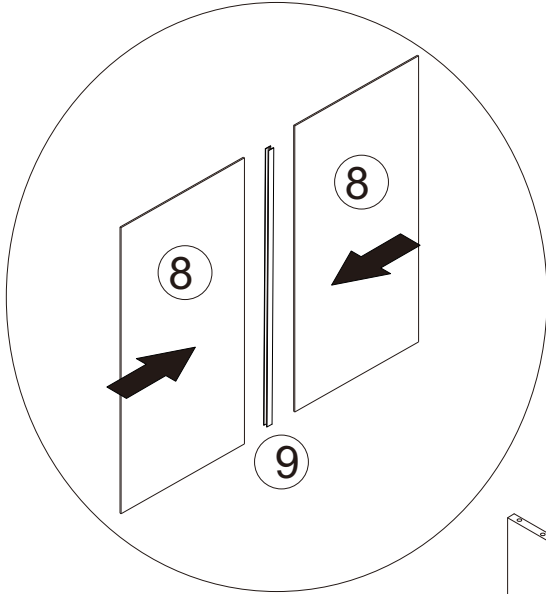

-  Cx4
-  Ex4
-  Hx4
-  Qx5

Step 7

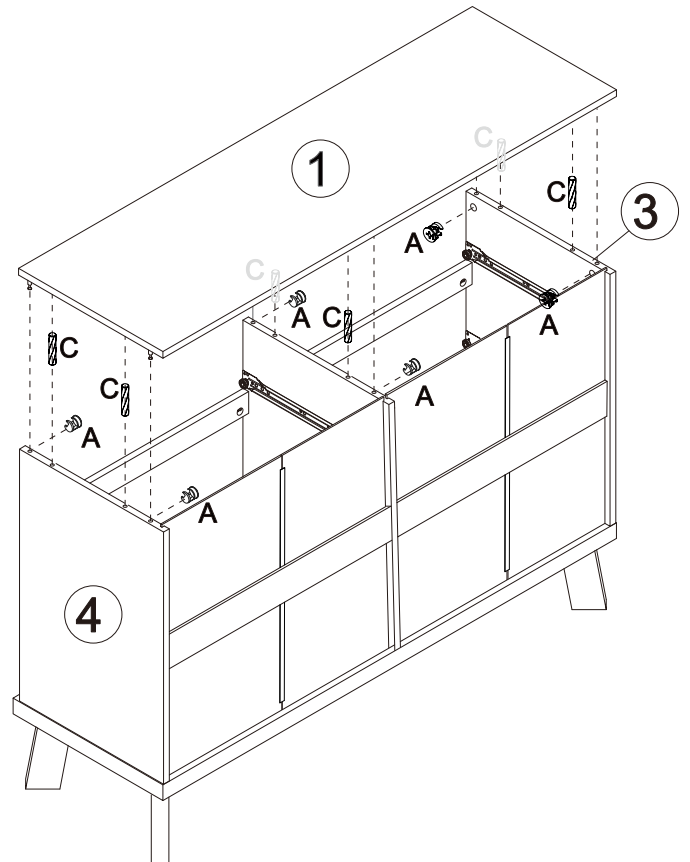
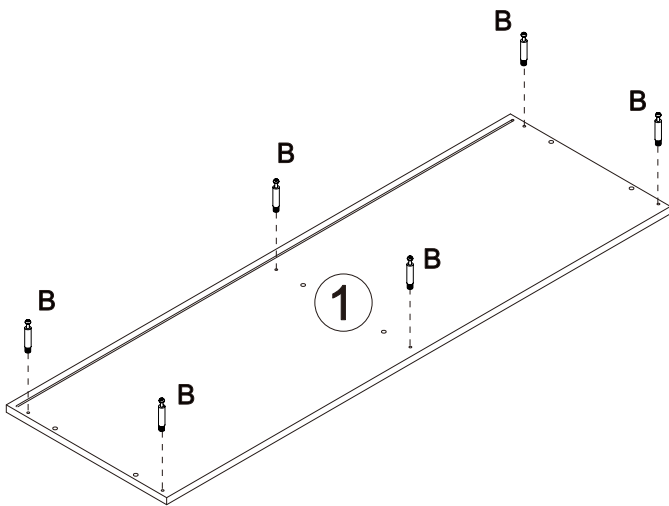

Step 8



- | | |
|--|-----|
|  | Ax6 |
|  | Bx6 |
|  | Cx6 |

Step 9

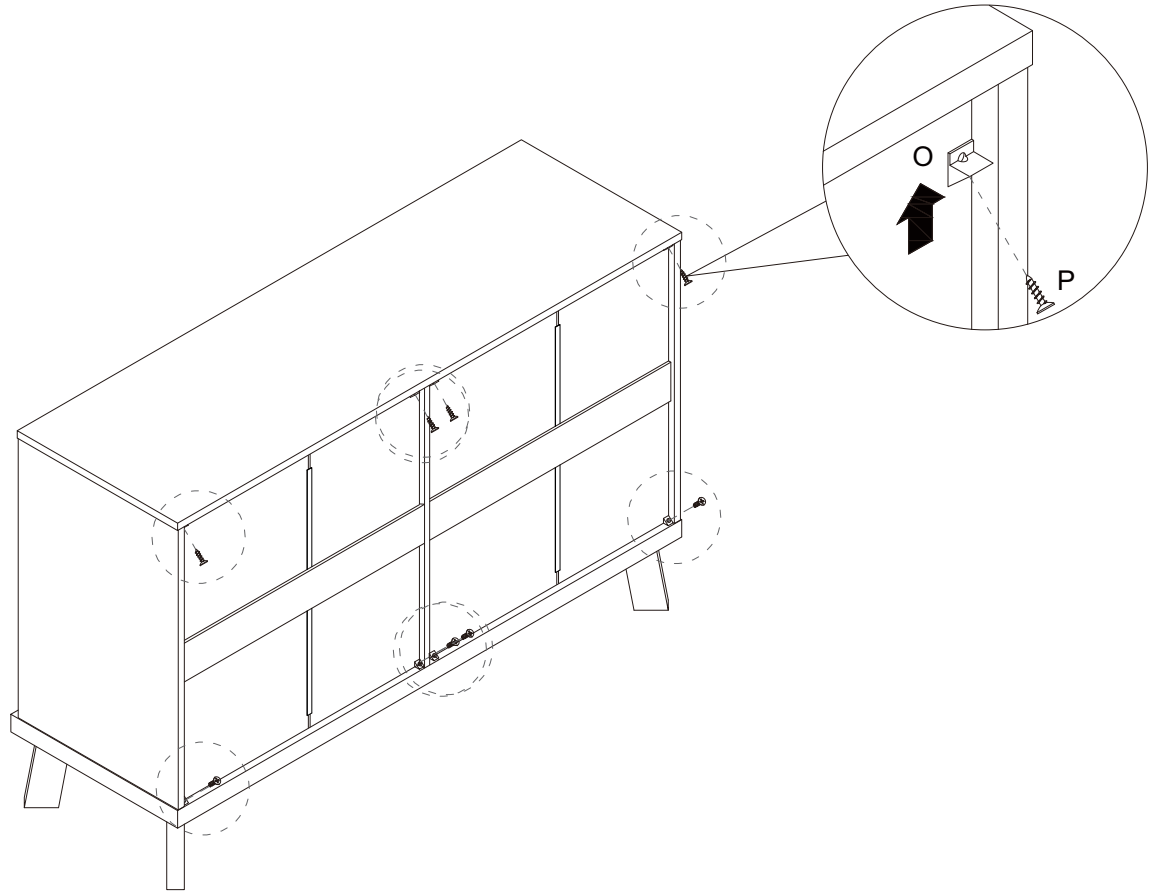

Ox8



Px8

Step 10

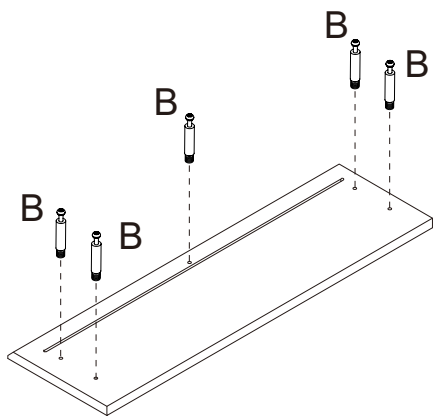

10

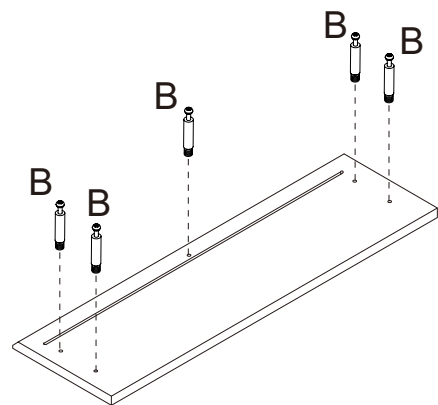

11

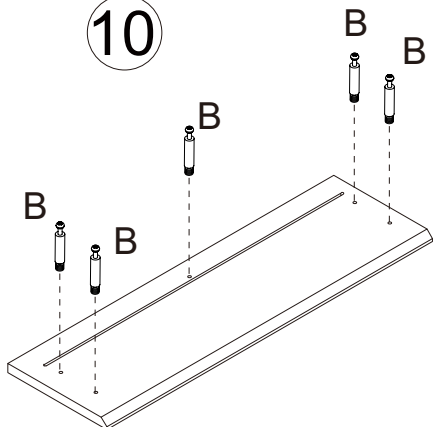

12 X 2

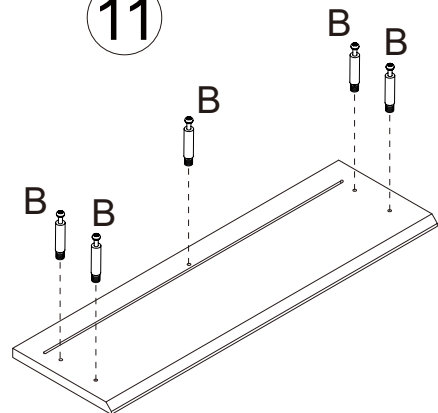

13 X 2



Bx30

Step 11

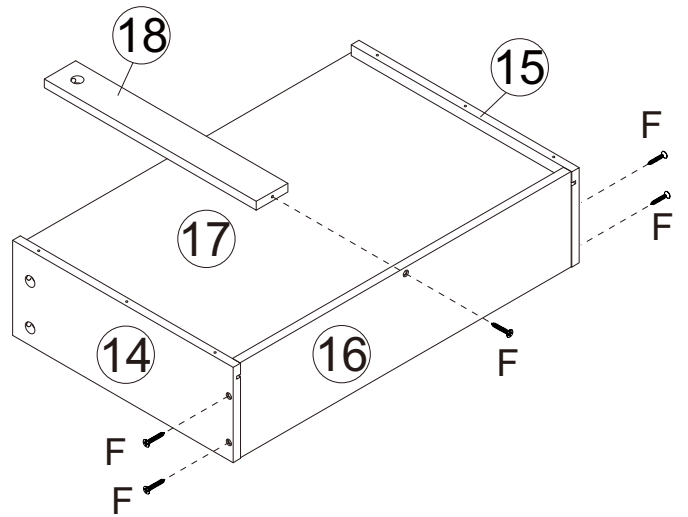
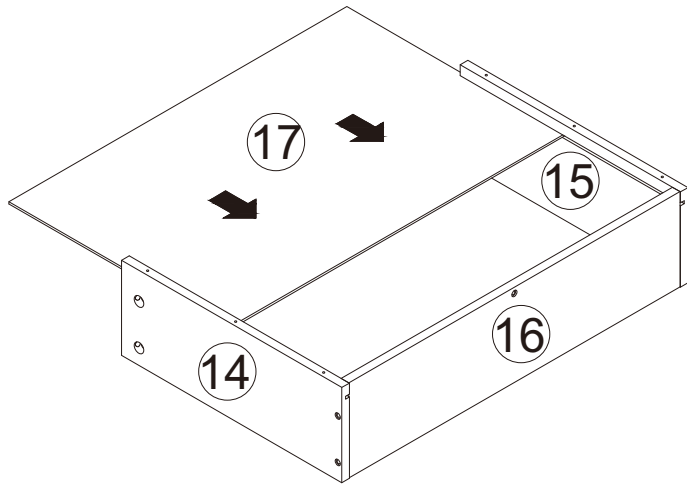

X 6



Fx30

Step 12

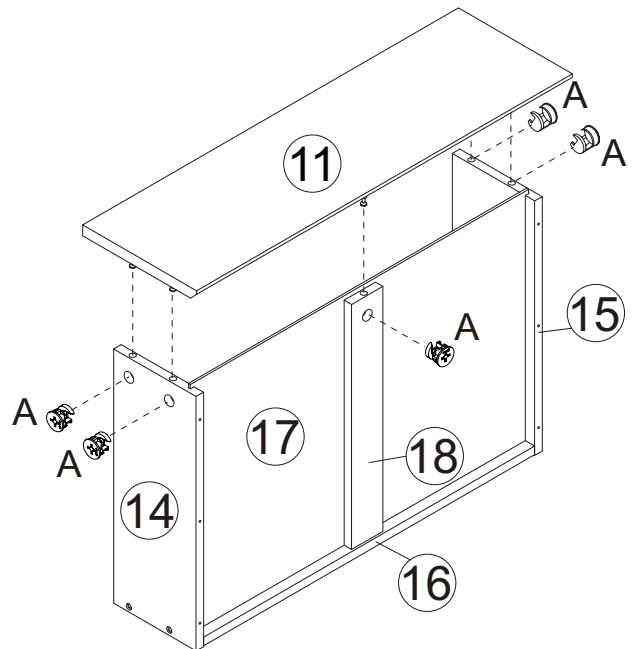
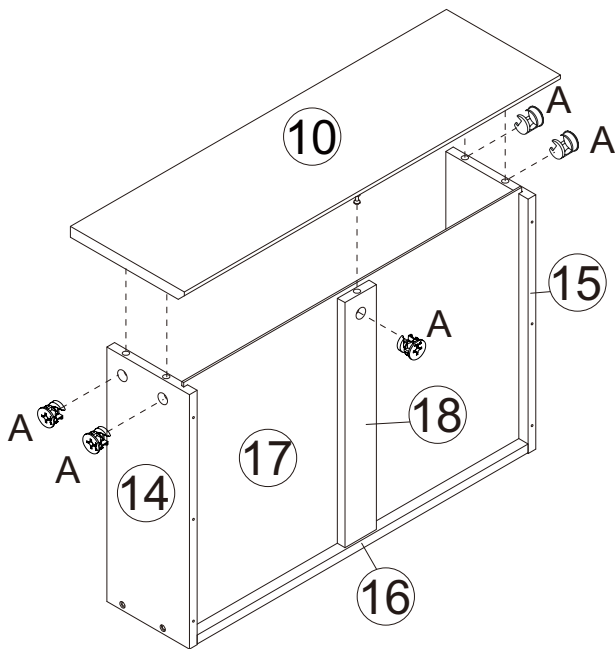

Ax10

Step 13

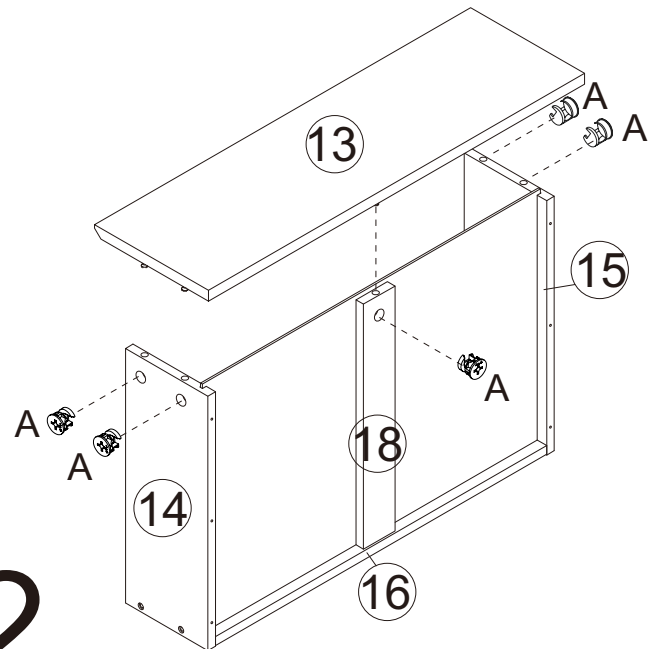
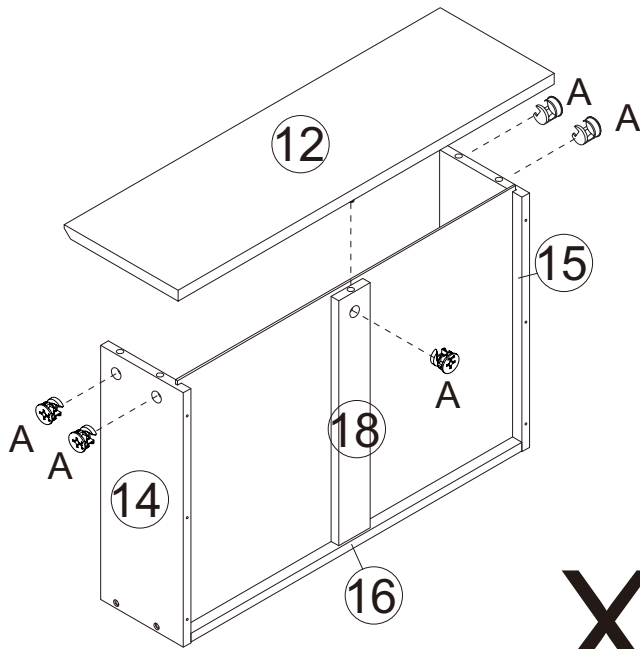

X 2



Ax20

Step 14

Drawers x6

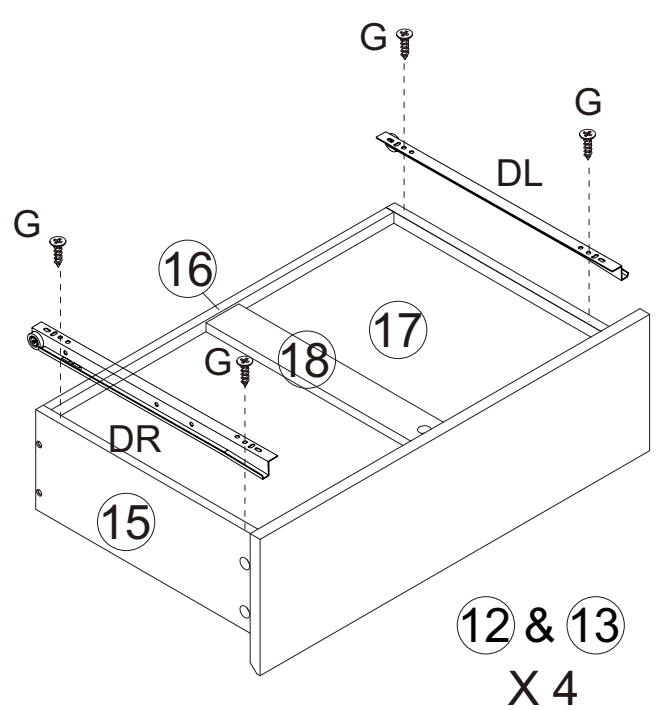
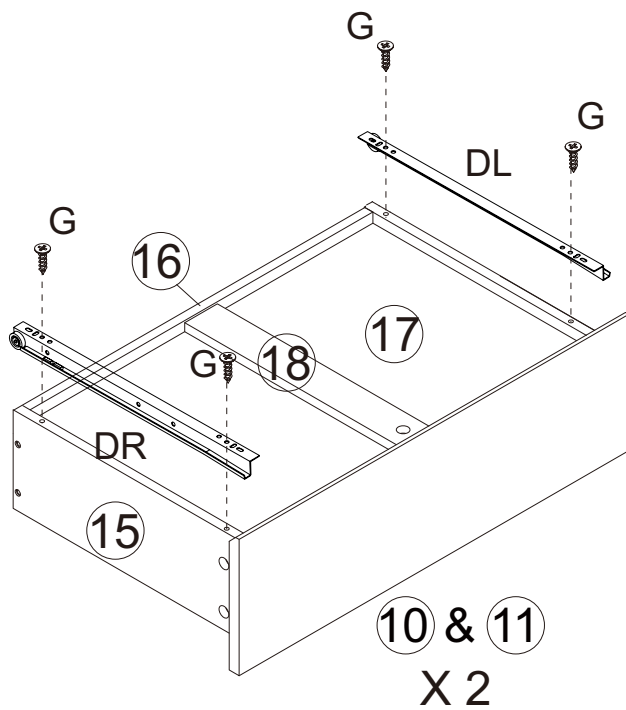

Gx24



DLx6





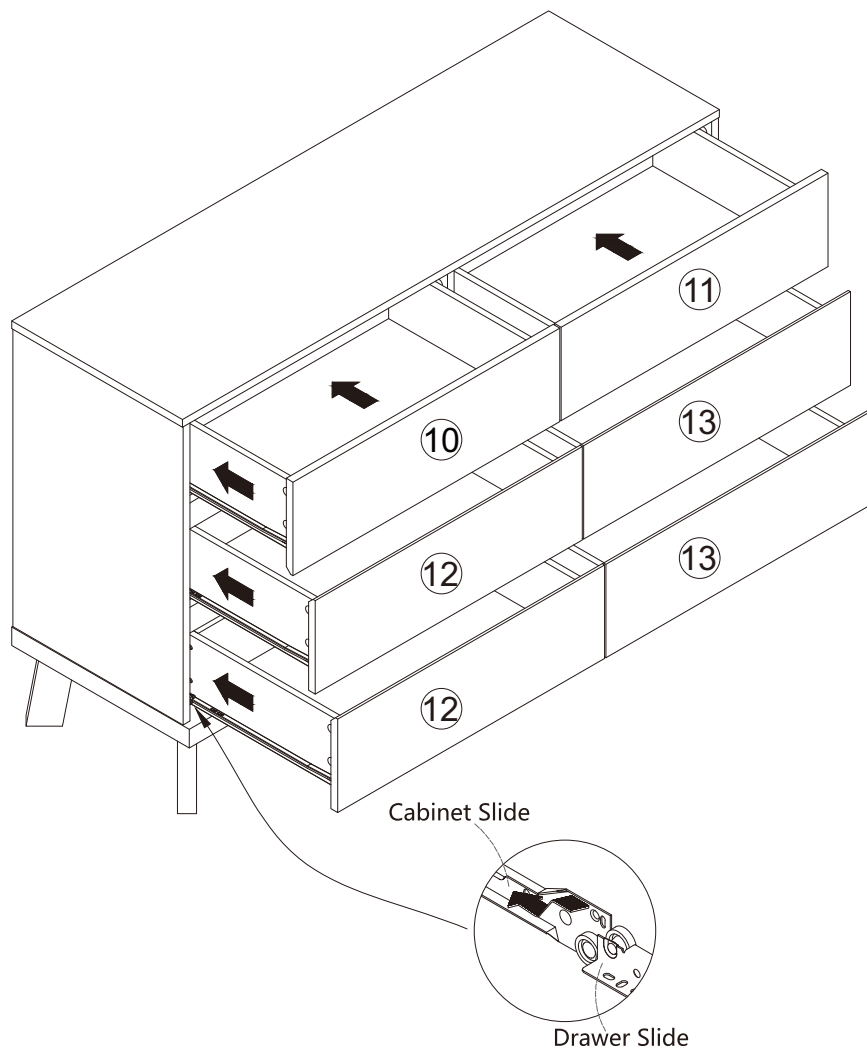

DRx6

Step 15

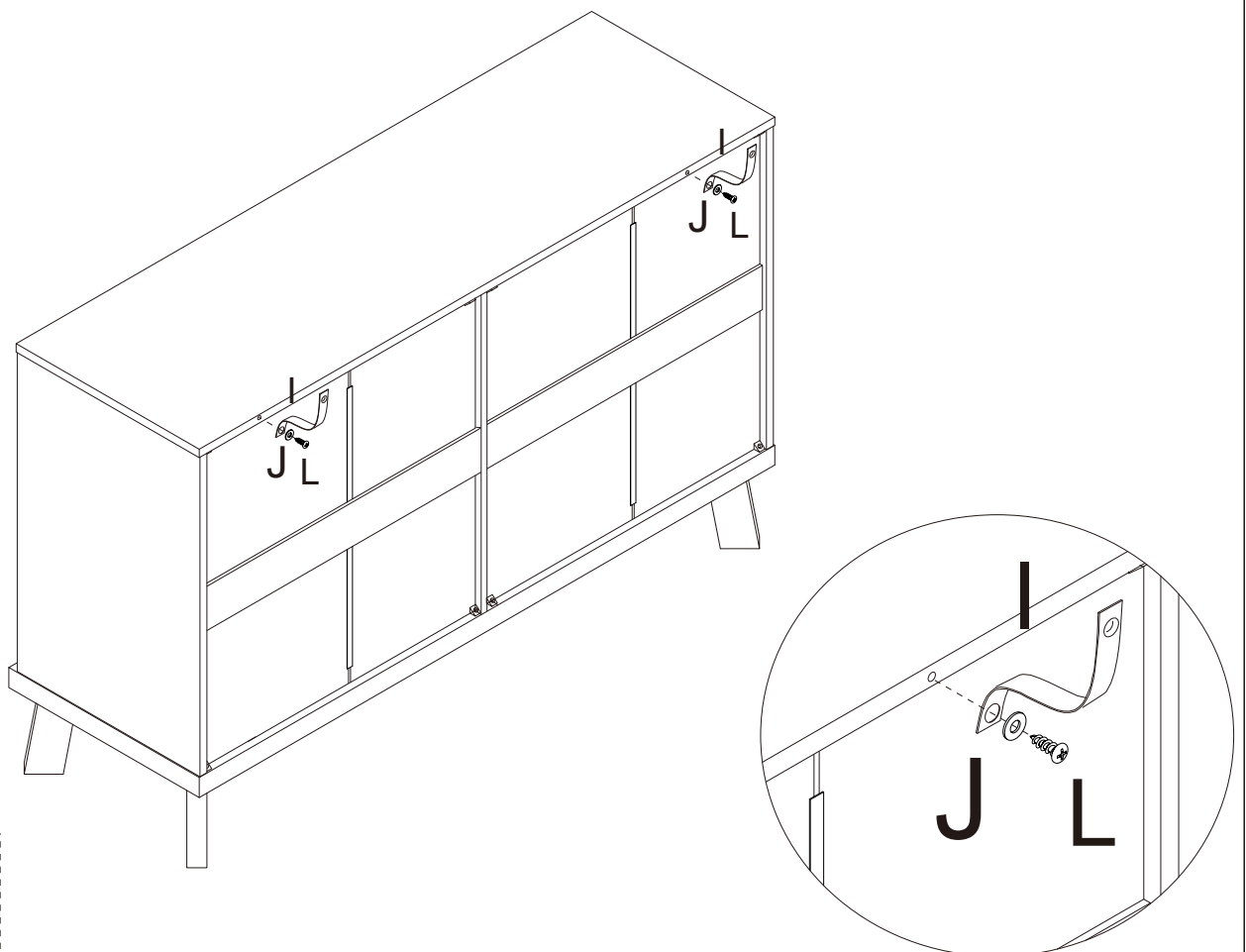





Step 16

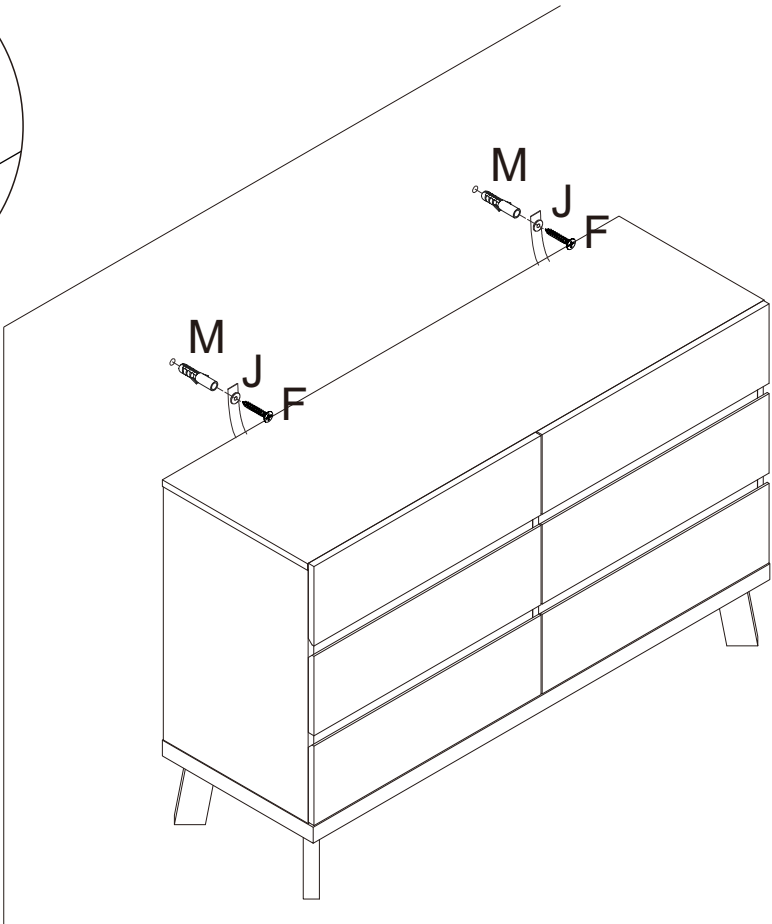
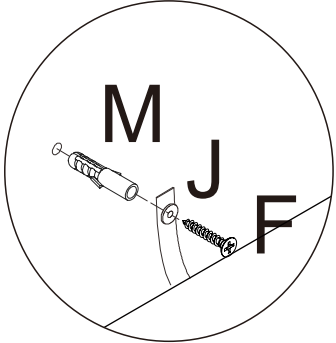

- | | |
|--|-----|
|  | Ix2 |
|  | Jx2 |
|  | Lx2 |

Step 17



	Fx2
	Jx2
	Mx2