

WOODEN SWING SET- AC0701H

INSTALLATION AND OPERATING INSTRUCTIONS

OBSTACLE FREE SAFETY ZONE - 313" x 336" x 188 3/16" (7.95 m x 8.54m x 4.78 m) area requires Protective Surfacing. See page 3.

MAXIMUM VERTICAL FALL HEIGHT - 79 1/8" (2.01 m).

CAPACITY - 6 Users Maximum, Ages 3 to 10; Weight Limit 110 lbs. (50 kg) per child.

RESIDENTIAL HOME USE ONLY. Not intended for public areas such as multi-unit residences, schools, churches, nurseries, day cares or parks.

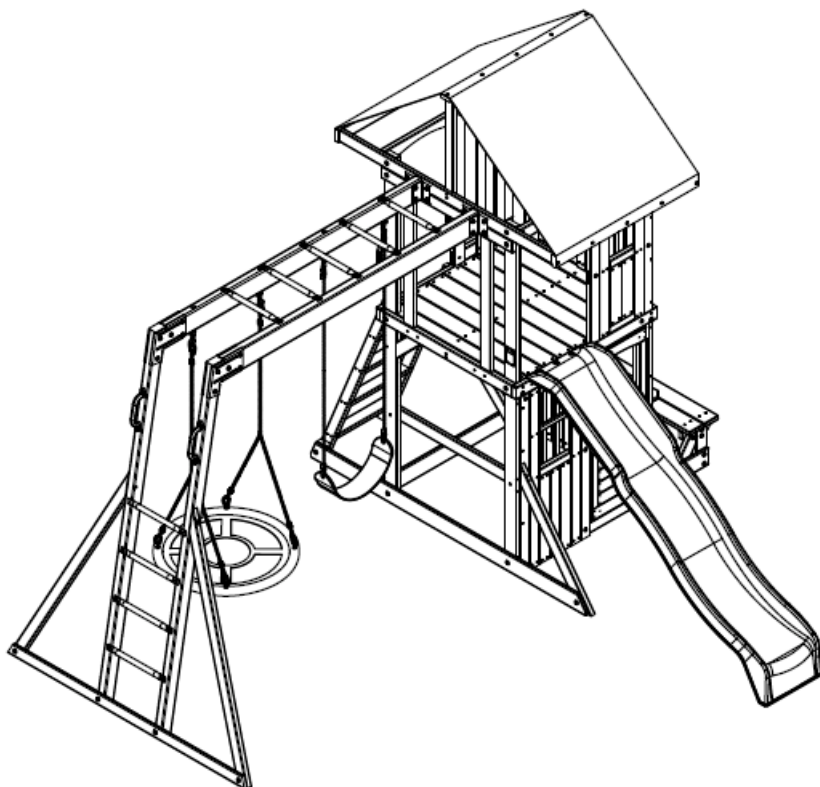

Warning. Only for domestic use

Shenzhen Jia De Fu Ke Ji You Xian Gong Si
1802 Building 6, Phase II Runyuan Xingfu City,
Longhua District Shenzhen City, China
0086-152 7759 8658
yangklokick8658@outlook.com

⚠️WARNING

To reduce the risk of serious injury or death, please read and follow these instructions. Keep and refer to instructions as needed and pass along to any future owners of this item.

Warnings and Safe Play Instructions



CONTINUOUS ADULT SUPERVISION REQUIRED. Most serious injuries and deaths on playground equipment have occurred while children were unsupervised! Our products are designed to meet mandatory and voluntary safety standards. Complying with all warnings and recommendations in these instructions will reduce the risk of serious or fatal injury to children using this play system. Go over the warnings and safe play instructions regularly with your children and make certain that they understand and follow them. Remember on-site adult supervision is required for children of all ages.



WARNING

SERIOUS HEAD INJURY HAZARD

Installation over concrete, asphalt, dirt, grass, carpet and other hard surface creates a risk of serious injury or death from falls to the ground. Install and maintain shock absorbing material under and around play-set as recommended on page 3 of these instructions.

COLLISION HAZARD

Place play-set on level ground at least 2m from any obstruction such as a garage or house, fences, poles, trees, sidewalks, walls, landscape timbers, rocks, pavement, planters, garden borders, overhanging branches, laundry lines, and electrical wires. (See OBSTACLE FREE SAFETY ZONE on cover)

CHOKING HAZARD/SHARP EDGES & POINTS

Adult assembly required. This product contains small parts and parts with sharp edges and points. Keep parts away from children until fully assembled.

WARNING LABEL

Owners shall be responsible for maintaining the legibility of the warning labels.

STRANGULATION HAZARD

- NEVER allow children to play with ropes, clotheslines, pet leashes, cables, chains or cord-like items when using this play-set or to attach these items to play-set.
- NEVER allow children to wear loose fitting clothing, ponchos, hoods, scarves, capes, necklaces, items with draw-strings, cords or ties when using this play-set.
- NEVER allow children to wear bike or sport helmets when using this play-set.

Failure to prohibit these items, even helmets with chin straps, increases the risk of serious injury and death to children from entanglement and strangulation.

TIP OVER HAZARD

Choose a level location for the equipment. This can reduce the likelihood of the play set tipping over and loose-fill surfacing materials washing away during heavy rains.

DO NOT allow children to play on the play-set until the assembly is complete and the unit is properly anchored.

Never add extra length to chain or rope. The chains or ropes provided are the maximum length designed for the swinging element(s).



WARNING – Safe Play Instructions

- ✓ Observe capacity limitations of your play-set. See front cover.
- ✓ Dress children with well fitting and full foot enclosing footwear.
- ✓ Teach children to sit with their full weight in the center of the swing seat to prevent erratic swing motion or falling off.
- ✓ Check for splintered, broken or cracked wood; missing, loose, or sharp edged hardware. Replace, tighten and or sand smooth as required prior to playing.
- ✓ Verify that suspended climbing ropes, rope ladders, chain or cable are secured at both ends and cannot be looped back on itself as to create an entanglement hazard.
- ✓ On sunny and or hot days, check the slide and other plastic rides to assure that they are not very hot as to cause burns. Cool hot slide and rides with water and wipe dry prior to using.
- ✓ Orientate slide such that it gets the least amount of exposure to the sun.
- ✗ Do not allow children to wear open toe or heel footwear like sandals, flip-flops or clogs.
- ✗ Do not allow children to walk, in front, between, behind or close to moving rides.
- ✗ Do not let children twist swing chains or ropes or loop them over the top support bar. This may reduce the strength of the chain or rope and cause premature failure.
- ✗ Do not let children get off rides while they are in motion.
- ✗ Do not permit climbing on equipment when it is wet.
- ✗ Do not permit rough play or use of equipment in a manner for which it was not intended. Standing on or jumping from the roof, elevated platforms, swings, climbers, ladders or slide can be dangerous.
- ✗ Do not allow children to swing empty rides or seats.
- ✗ Do not allow children to go down slide head first or run up slide.

⚠️ Protective Surfacing - Reducing Risk of Serious Head Injury From Falls

One of the most important things you can do to reduce the likelihood of serious head injuries is to install shock-absorbing protective surfacing under and around your play equipment. The protective surfacing should be applied to a depth that is suitable for the equipment height in accordance with ASTM F1292. There are different types of surfacing to choose from; whichever product you select, follow these guidelines:

Loose-Fill Materials

- Maintain a minimum depth of 9 inches (23 cm) of loose-fill materials such as wood mulch/chips, engineered wood fiber (EWF), or shredded/recycled rubber mulch for equipment up to 8 feet (2.45 m) high; and 9 inches (23 cm) of sand or pea gravel for equipment up to 5 feet (1.5 m) high. NOTE: An initial fill level of 12 inches (31 cm) will compress to about a 9-inch (23 cm) depth of surfacing over time. The surfacing will also compact, displace, and settle, and should be periodically raked and refilled to maintain at least a 9-inch (23 cm) depth.
- Use a minimum of 6 inches (16 cm) of protective surfacing for play equipment less than 4 feet (1.22 m) in height. If maintained properly, this should be adequate. (At depths less than 6 inches (16 cm), the protective material is too easily displaced or compacted.)

NOTE: Do not install home playground equipment over concrete, asphalt, or any other hard surface. A fall onto a hard surface can result in serious injury to the equipment user. Grass and dirt are not considered protective surfacing because wear and environmental factors can reduce their shock absorbing effectiveness. Carpeting and thin mats are not adequate protective surfacing. Ground level equipment -- such as a sandbox, activity wall, playhouse or other equipment that has no elevated play surface -- does not need any protective surfacing.

- Use containment, such as digging out around the perimeter and/or lining the perimeter with landscape edging. Don't forget to account for water drainage.
- Periodically rake, check and maintain the depth of the loose-fill surfacing material. Marking the correct depth on the play equipment support posts will help you to see when the material has settled and needs to be raked and or replenished. Be sure to rake and evenly redistribute the surfacing in heavily used areas.
- Do not install loose fill surfacing over hard surfaces such as concrete or asphalt.

Poured-In-Place Surfaces or Pre-Manufactured Rubber Tiles

You may be interested in using surfacing other than loose-fill materials - like rubber tiles or poured-in-place surfaces.

- Installations of these surfaces generally require a professional and are not “do-it yourself” projects.
- Review surface specifications before purchasing this type of surfacing. Ask the installer/manufacturer for a report showing that the product has been tested to the following safety standard: ASTM F1292 *Standard Specification for Impact Attenuation of Surfacing Materials within the Use Zone of Playground Equipment*. This report should show the specific height for which the surface is intended to protect against serious head injury. This height should be equal to or greater than the fall height - vertical distance between a designated play surface (*elevated surface for standing, sitting, or climbing*) and the protective surfacing below - of your play equipment.
- Check the protective surfacing frequently for wear.

Placement

Proper placement and maintenance of protective surfacing is essential. Refer to diagram on front cover. Be sure to;

- Extend surfacing at least 6 feet (1.8 m) from the equipment in all directions.
- For to-fro swings, extend protective surfacing in front of and behind the swing to a distance equal to twice the height of the top bar from which the swing is suspended.
- For tire swings, extend surfacing in a circle whose radius is equal to the height of the suspending chain or rope, plus 6 feet (1.8 m) in all directions.

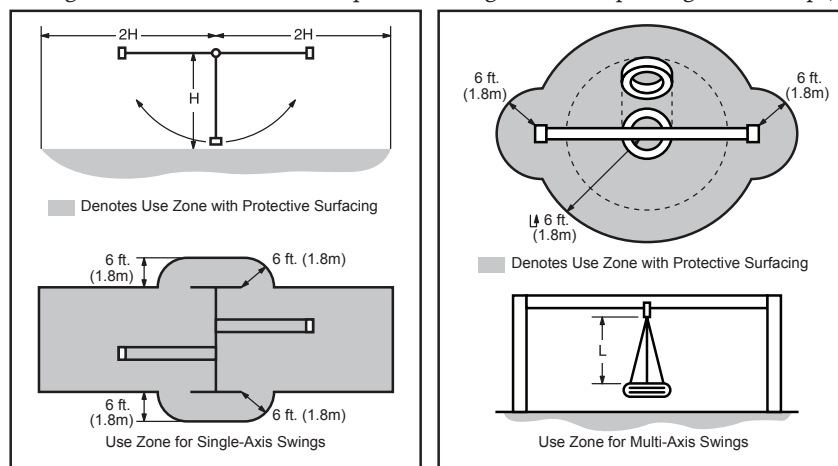

From the CPSC Outdoor Home Playground Safety Handbook. At <https://www.cpsc.gov/s3fs-public/324.pdf>

Instructions for Proper Maintenance

Keeping your playhouse in good condition is essential to reduce injuries. Save this document and assembly instructions so you can order parts that break or wear out. Inspect your playhouse at regular intervals to make sure that assembly integrity has been maintained. Pointing out that if these checks are not carried out the activity toy could overturn or otherwise become a hazard. The following maintenance schedule is recommended:

Check the following at the beginning of the play season:

HARDWARE:

- ✓ Check metal parts for rust. If found, sand and repaint using a non-lead paint complying with 16 CFR 1303.
- ✓ Inspect and tighten all hardware. On wood assemblies **DO NOT OVER-TIGHTEN** as to cause crushing and splintering of wood.
- ✓ Check for sharp edges or protruding screw threads, add washers if required.

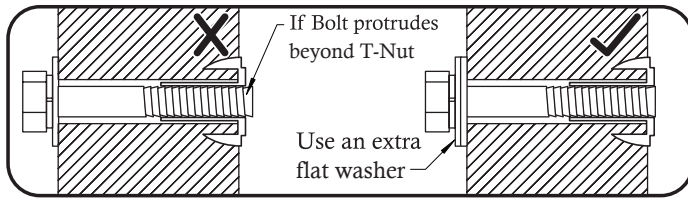
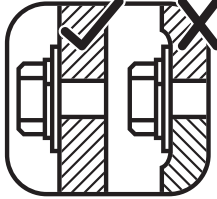

SHOCK ABSORBING SURFACING:

- ✓ Check for foreign objects. Rake and check depth of loose fill protective surfacing materials to prevent compaction and maintain appropriate depth. Replace as necessary. (See Protective Surfacing, page 3)

SWING HANGERS:

- ✓ Check that bolts are secure and tight. Quick clips should be completely closed and threaded clips screwed tight.
- ✓ If squeaking occurs lubricate bushings with oil or WD-40®.

SWINGS, ROPES AND RIDES:

- ✓ Reinstall if removed during cold season. Check all moving parts including swing seats, ropes, chains and attachments for wear, rust and other deterioration. Replace as needed.
- ✓ Check that ropes are tight, secure at both ends and cannot loop back as to create an entrapment.

GROUND STAKES (ANCHORS):

- ✓ Check for looseness, damage or deterioration. Should firmly anchor unit to ground during use, Re-secure and or replace, if necessary.
- ✓ Detailed instructions on how anchors shall be installed to prevent overturning or lifting of the support members when they are used as intended or in a foreseeable way, taking into account the condition of the soil normally encountered.
- ✓ Instructions that anchors shall be placed level with or under the ground in order to reduce tipping hazards.

WOOD PARTS:

- ✓ Check all wood members for deterioration, structural damage and splintering. Sand down splinters and replace deteriorated wood members. As with all wood, some checking and small cracks in grain is normal.
- ✓ Applying a water repellent or stain (water-based) on a yearly basis is important maintenance to maintain maximum life and performance of the product.

Check all protective coverings on bolts, pipes, edges, and corners. Replace if they are loose, cracked, or missing.

Check twice a month during play season:

HARDWARE:

- ✓ Inspect for tightness. Must be firmly against, but not crushing the wood. **DO NOT OVER-TIGHTEN.** This will cause splintering of wood.
- ✓ Check for sharp edges or protruding screw threads. Add washers if required.

SHOCK ABSORBING SURFACING:

- ✓ Rake and check depth of loose fill protective surfacing materials to prevent compaction and maintain appropriate depth. Replace as necessary. (See Protective Surfacing, page 3)

Check once a month during play season:

SWING HANGERS:

- ✓ Check that they are secure and orientated correctly. Hook should rotate freely and perpendicular to support beam.
- ✓ If squeaking occurs lubricate bushings with oil or WD-40®.

SWINGS AND RIDES:

- ✓ Check swing seats, all ropes, chains and attachments for fraying, wear, excessive corrosion or damage. Replace if structurally damaged or deteriorated.

Check at the end of the play season:

SWINGS AND RIDES:

- ✓ To prolong their life, remove swings and store inside when outside temperature is below 32°F/0°C. Below freezing, plastic parts may become more brittle.

SHOCK ABSORBING SURFACING:

- ✓ Rake and check depth of loose fill protective surfacing materials to prevent compaction and maintain appropriate depth. Replace as necessary. (See Protective Surfacing, page 3)

If you dispose of your play set: Please disassemble and dispose of your unit so that it does not create any unreasonable hazards at the time it is discarded. Be sure to follow your local waste ordinances.

Maintenance to be carried out under the direct supervision of a responsible adult. Colour, designs and decorations may vary from those shown in the photographs.

Keys to Assembly Success

Required Tools

- Carpenters Level
- Carpenters Square
- Claw Hammer
- Pencil
- Rubber Mallet
- Power Drill
- Ratchet With Extension
7/16"(11mm)&1/2"(13mm) Sockets
- 8' (2.4m) Step Ladder
- Safety Glasses And Gloves
- Tape Measure
- 3/16"(5mm) Hex Key
- 1/8" (3mm) Drill Bits
- Adult Helpers

Part Identification instructions

The Parts required for each step can be found in the bottom right part of every page

Part Numbers

Part Numbers are referenced on the first page of the step-by-step instructions below. To avoid damage to the playhouse or injury from incorrect assembly, please ensure you have properly identified and prepared each part required for the relevant step before assembly.

Basic Safety - Powered Hand Tools - Electric Tools

When and how should you inspect powered hand tools?	What should you do while using powered hand tools?	What should you avoid when using powered tools?
<p>Inspect tools for any damage prior to each use. Check the handle and body casing of the tool for cracks or other damage. If the tool has auxiliary or double handles, check to see that they installed securely. Check for damaged switches and ones with faulty trigger locks. Inspect the plug for cracks and for missing, lose or faulty prongs.</p> <p>What should you do before using powered hand tools?</p> <p>Ensure that you have been properly trained to use the tool safely. Ensure that the power tool has the correct guard, shield or other attachment that the manufacturer recommends. Ensure that the tools are properly grounded.</p>	<p>Wear or use personal protective equipment (PPE) or clothing that is appropriate for the work you are doing; this may include items such as safety glasses or goggles, or a face shield (with safety glasses or goggles), hearing protection, dust mask, gloves, safety boots or shoes, or rubber boots. Switch off the tools before connecting them to a power supply. If a power cord feels more than comfortably warm or if a tool is sparking, please let us know. Remove any wrenches and adjusting tools before turning on a tool. During use, keep power cords clear of tools and the path that the tool will take. Use clamps, a vice or other devices to hold and support the piece being worked on, when practical to do so. Follow good housekeeping procedures – keep the work area free of clutter and debris that could be tripping or slipping hazards.</p>	<p>Do not wear gloves, loose clothing or jewellery while using revolving power tools. Tie back long hair or wear appropriate hair protection to prevent hair from getting caught in moving parts of equipment. Do not use a tool unless you have been trained to use it safely and know its limitations and hazards. Avoid accidental starting by ensuring the tool is turned off before you plug it in. Also do not walk around with a plugged-in tool with your finger touching the switch. Do not leave a running tool unattended. Do not leave it until it has been turned off, has stopped running completely, and has been unplugged. Stop using an electric power tool if you feel a tingle in your fingers. This is a warning that the tool is faulty and needs repair. Do not carry electrical tools by the power cord. Do not brush away sawdust, shavings or turnings while the tool is running. Do not surprise or touch anyone who is operating a tool. Startling a tool operator could end up causing an accident or injury.</p>

Protrusion Hazard

Protrusion hazard means a component or piece of hardware that could impale or cut a child if the child falls against it. After you have completed a assembly step, please inspect the part for exposed

threads. If a thread protrudes from the T-Nut, undo the entire bolt, and add washers to eliminate the risk of a protrusion hazard.

Proper Hardware Assembly

As a general rule of thumb, your pilot hole should be slightly smaller than the diameter of your screw. This will remove as much material as possible, which will reduce the likelihood of splitting, but will still leave enough material for the screw's threads to grip into. Once the pilot hole is drilled, you can install the screw. Drive the screw in, being careful to angle it to follow the path of the hole. Repeat this process for each screw used. For large screw please first slip a flat washer over the screw.

For bolts, gently tap the relevant T-Nut into the hole using a hammer on the opposing site. Following the placement of the T-Nut, first slip a lock washer and a flat washer over the bolt. During the initial assembly you are not required to fully tighten the bolt to allow room for adjustment. Once your playhouse has been fully assembled, please ensure all bolts are fasten properly and that you have fully tightened all bolts used and no protrusion hazard has been created. Wafer head bolts with blue lock tight or a bolt with a Ny-Lok nut do **NOT** require a lock washer.

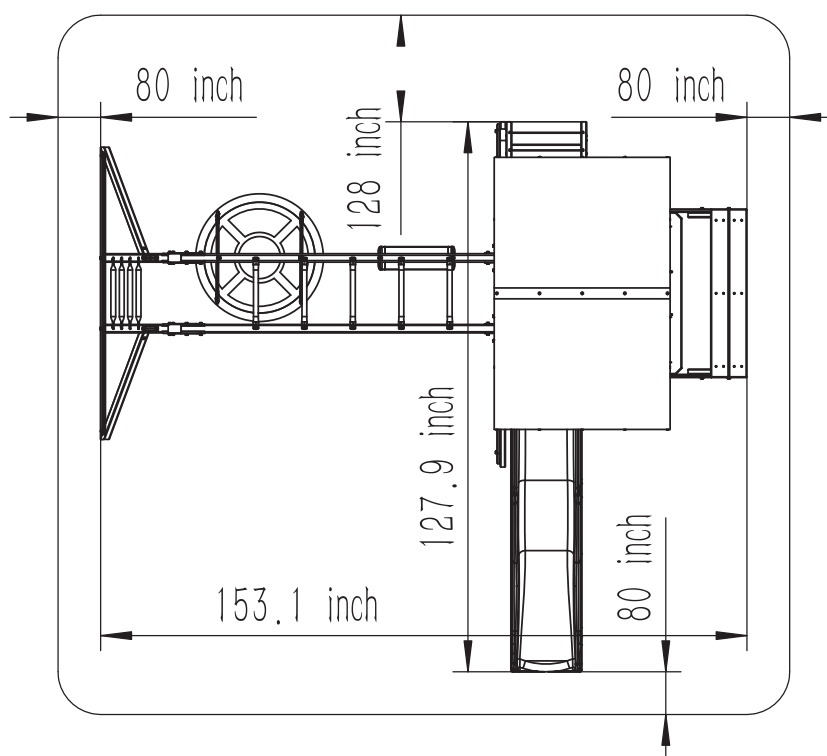
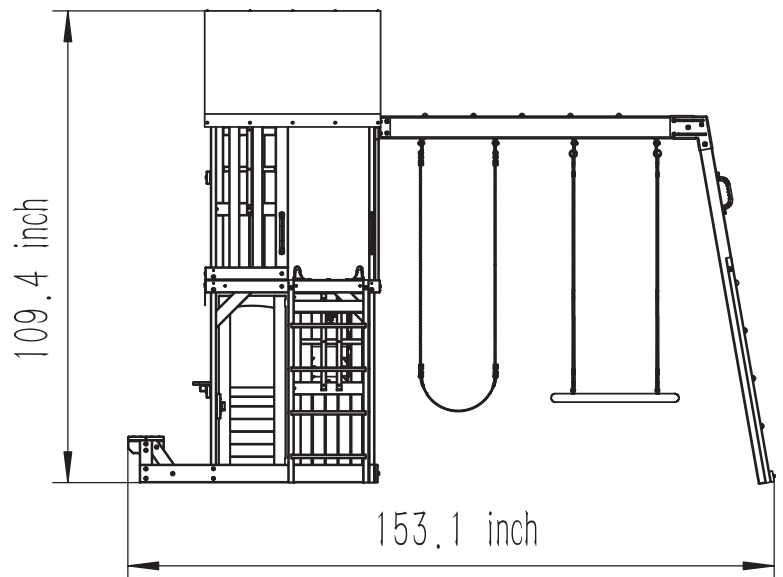
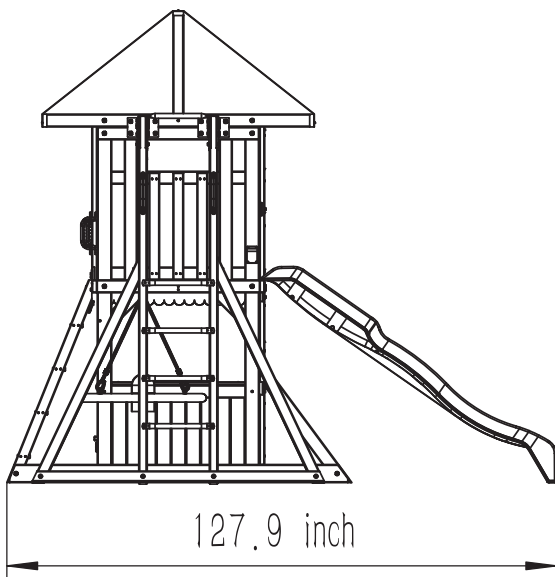

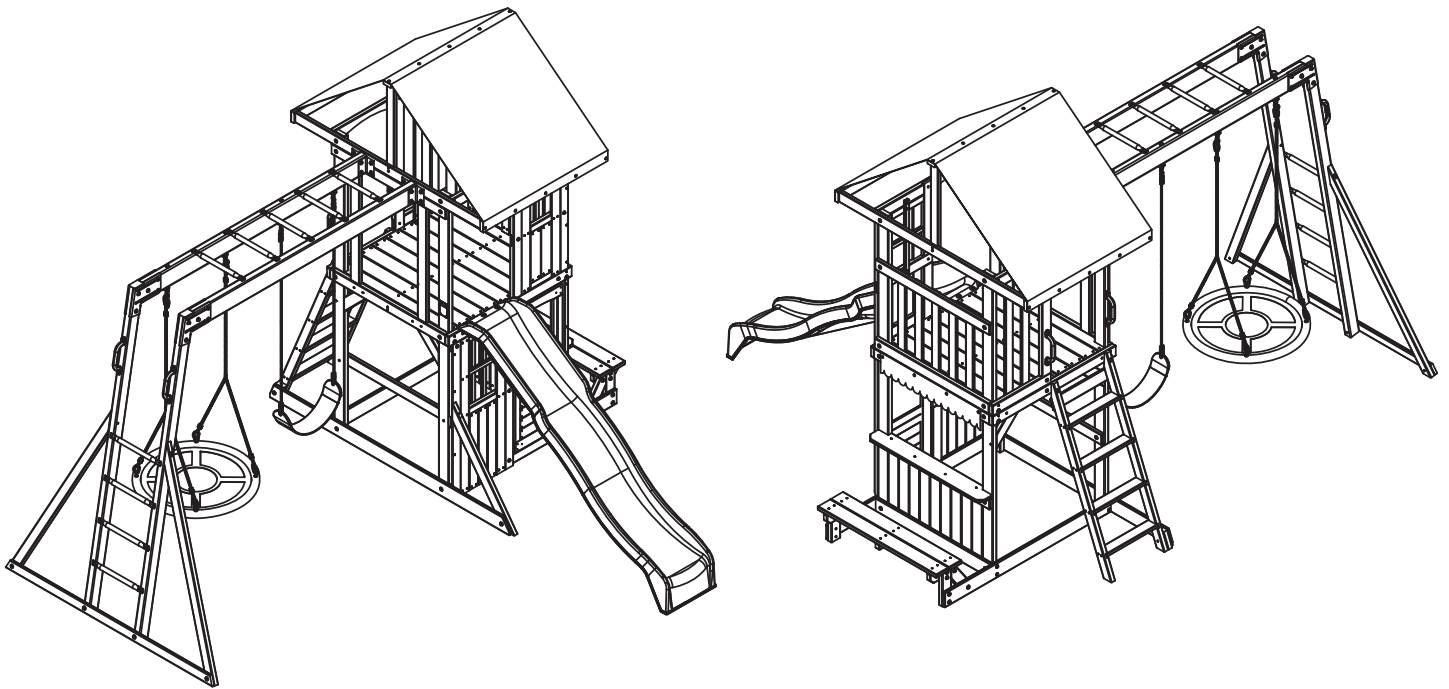

Carefully follow all directions. Scan the QR code to watch the installation guide.



12001 X1



12002 X1



12003 X1

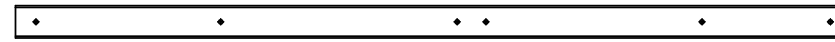

12004 X1

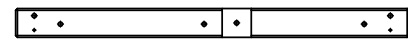

12005 X1



12006 X1



12007 X1

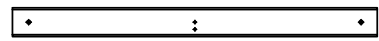

12008 X1

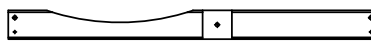

12009 X1

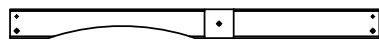

12010 X1

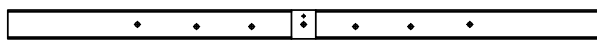

12011 X1

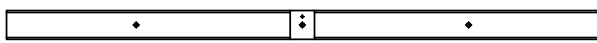

12012 X1



12013 X1



12014 X3

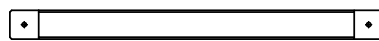

12015 X2

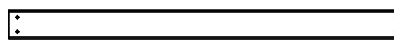

12017 X2



12016 X1



12018 X2

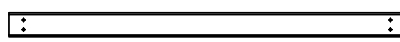

12019 X1

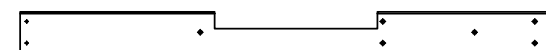

12020 X1



12021 X1

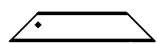

12022 X2

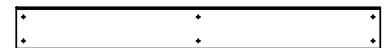

12023 X7

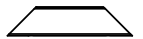

12024 X2



12025 X2



12026 X1



12027 X2

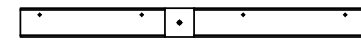
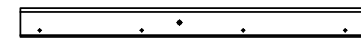

12028 X1



12029 X1

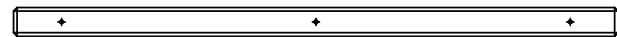

12030 X1

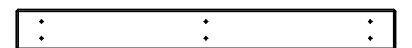

12031 X2



12032 X2



12033 X1



12034 X2



12035 X2

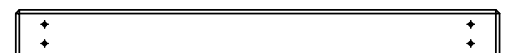

12036 X5

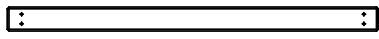

12037 X2



12038 X9



12039 X1



12040 X2

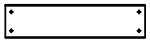

12041 X2

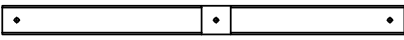
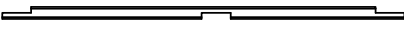
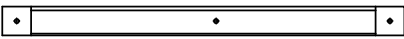

12042 X1

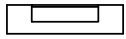

12043 X1

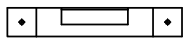

12044 X1

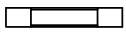

12045 X1



12046 X1



12047 X1

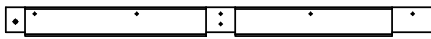
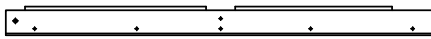

12048 X1



12049 X2

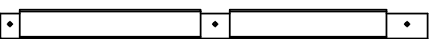

12050 X1



12051 X3

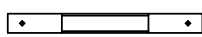

12052 X1

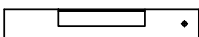

12053 X1



12054 X1



12055 X2

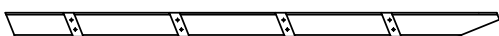

12056 X1

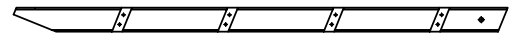

12057 X1



12058 X1



12059 X4

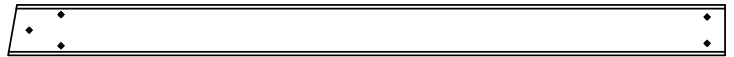
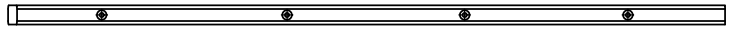

12060 X1



12061 X1



12062 X2

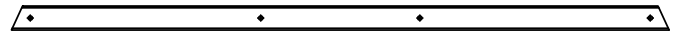

12063 X1



12064 X2



12065 X1



12066 X1

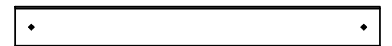

12067 X1



12068 X1

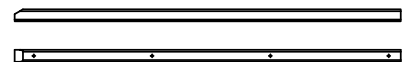

12069 X1



12070 X1



12071 X1

Hardware Identification (Actual Size)

9 x XG6 — 5/16 x 4 3/4"
7.8 x 120.6mm

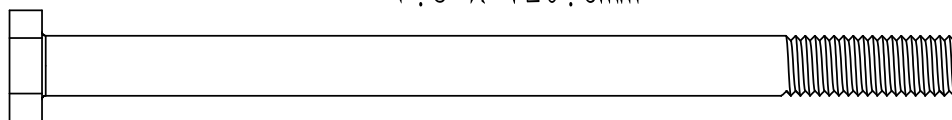

26 x XWL3 — 1/4 x 1 3/8"
6.3 x 34.9mm

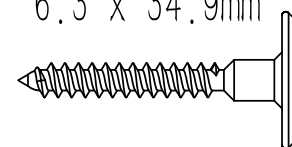

2 x XG21 — 5/16 x 3 3/4"
7.8 x 95.25mm

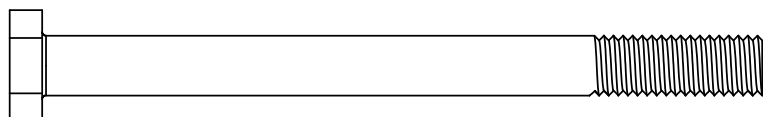

7 x XWL5 — 1/4 x 2 1/2"
6.3 x 63.5mm

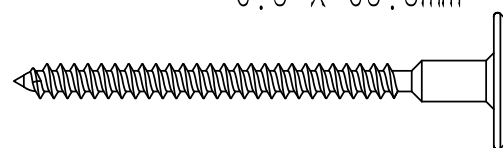

1 x XG11 — 5/16 x 3 1/2"
7.8 x 88.9mm

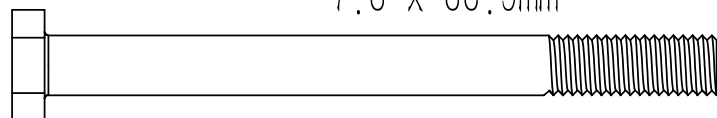

6 x XWB9 — 5/16 x 2 1/8"
7.8 x 54mm

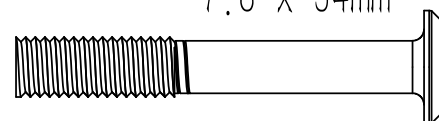

2 x XG10 — 5/16 x 3"
7.8 x 76.2mm

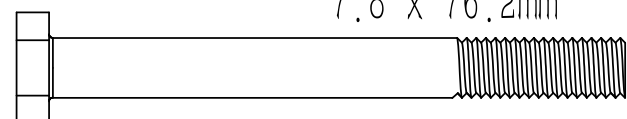

12 x XWB8 — 5/16 x 2 3/8"
7.8 x 60.3mm

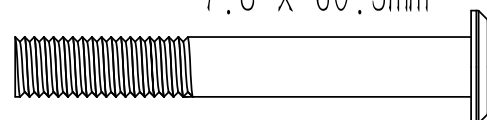

20 x XG36 — 5/16 x 2 3/4"
7.8 x 69.9mm

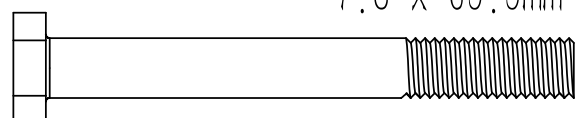

6 x XWB10 — 5/16 x 2 5/8"
7.8 x 66.68mm

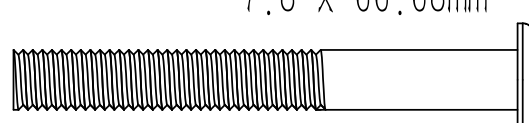

10 x XG9 — 5/16 x 2 1/2"
7.8 x 63.5mm

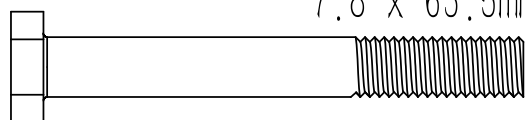

13 x XH9 — 1/4 x 1 1/4"
6.3 x 31.8mm

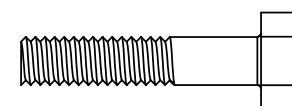

7 x XG8 — 5/16 x 2"
7.8 x 50.8mm

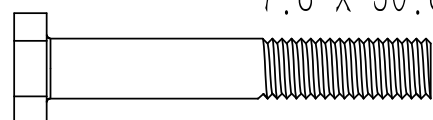

10 x XG27 — 5/16 x 1 3/4"
7.8 x 44.5mm

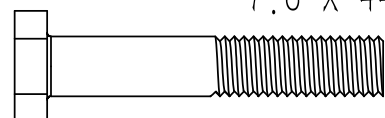

6 x XH8 — 1/4 x 4 1/4"
6.3 x 108mm

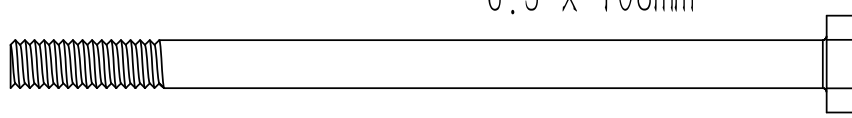

Hardware Identification (Actual Size)

7 x XS24 - #10 x 4"

4.8 x 101.6mm

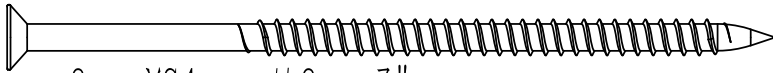

8 x XS4 - #8 x 3"

4.2 x 76.2mm

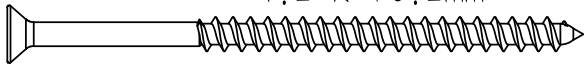

23 x XS3 - #8 x 2 1/2"

4.2 x 63.5mm



50 x XS11 - #8 x 2"

4.2 x 50.8mm



57 x XS2 - #8 x 1 1/2"

4.2 x 38.1mm



52 x XS20 - #8 x 1 3/8"

4.2 x 34.9mm



47 x XS1 - #8 x 1 1/8"

4.2 x 28.5mm



19 x XFW0 - 3/16"

4.8mm

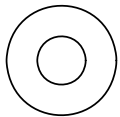

61 x XLW2 - 5/16"

7.9mm

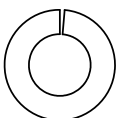

19 x XLW1 - 1/4"

6.4mm

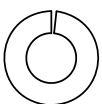

19 x XTN1 - 1/4"

6.4mm

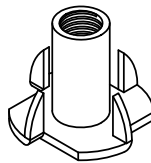

63 x XTN2 - 5/16"

7.9mm

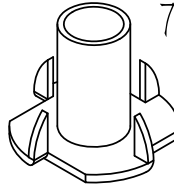

124 x XFW2 - 5/16"

7.9mm

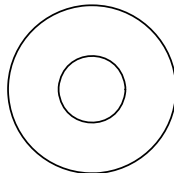

9 x XS7 - #12 x 2"

5.5 x 50.8mm

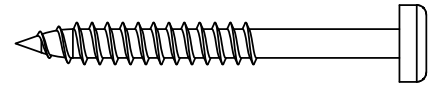

35 x XS0 - #8 x 7/8"

4.2 x 22.3mm

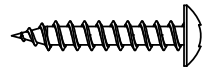

28 x XS10 - #8 x 1"

4.2 x 25.4mm



22 x XLN2 - 5/16"

7.9mm

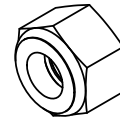

21 x XFW1 - 1/4"

6.4mm

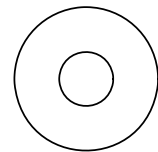

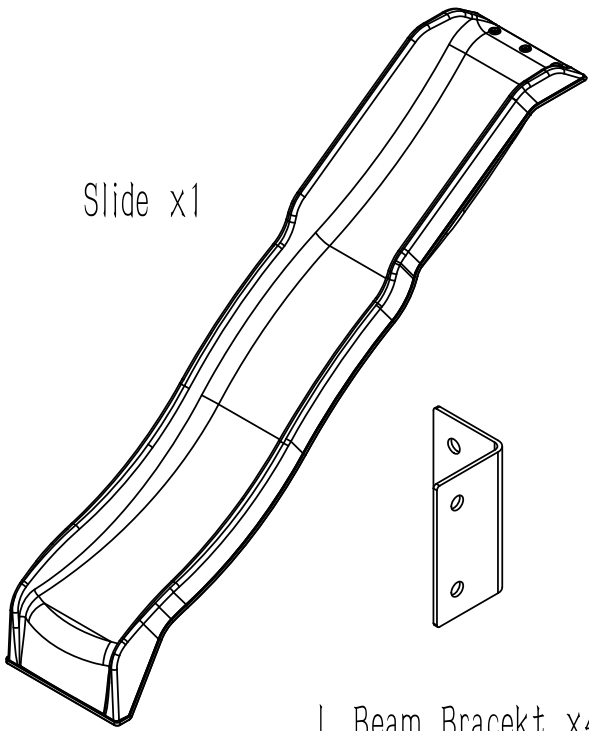

Slide x1

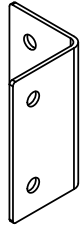

L Beam Bracket x4

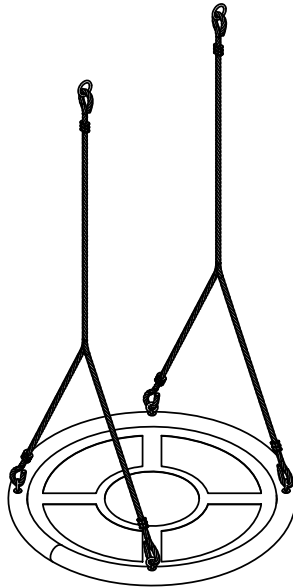

Nest Swing x1

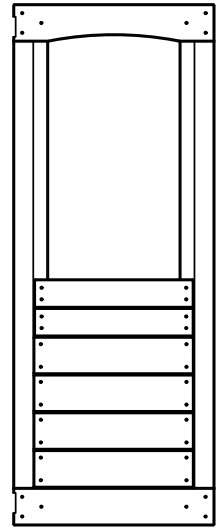

Door x1

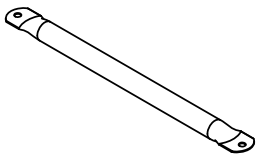

Monkey Bar x9

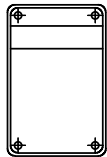

ID Plaque x1

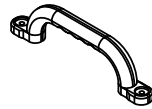

Handle x4

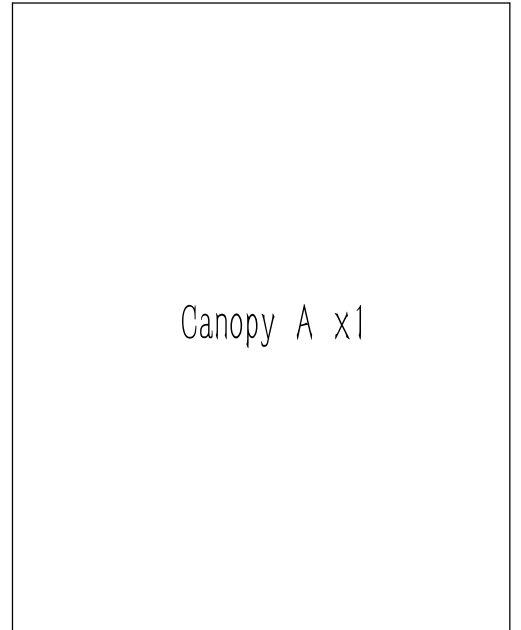

Canopy A x1

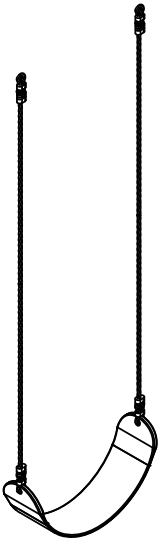

Swing x1

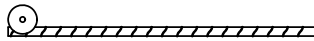

Ground Stake x6

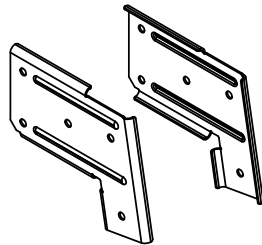

Beam Bracket x2

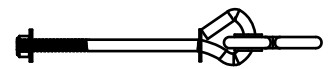

Bolt Swing Hanger x4

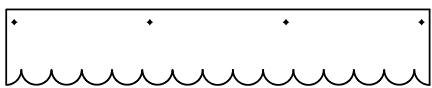

Canopy B x1

Door Hardware Bag x1

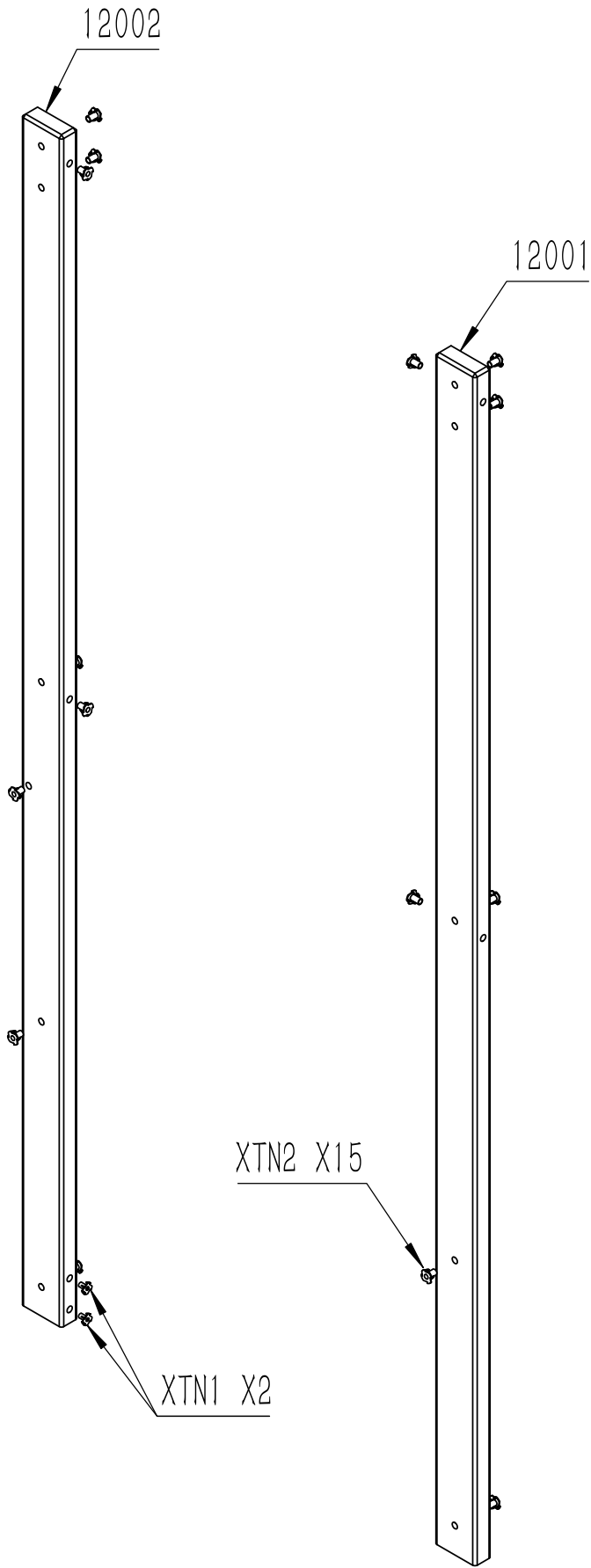

Parts	Qty
12001	1
12002	1
XTN1	2
XTN2	15

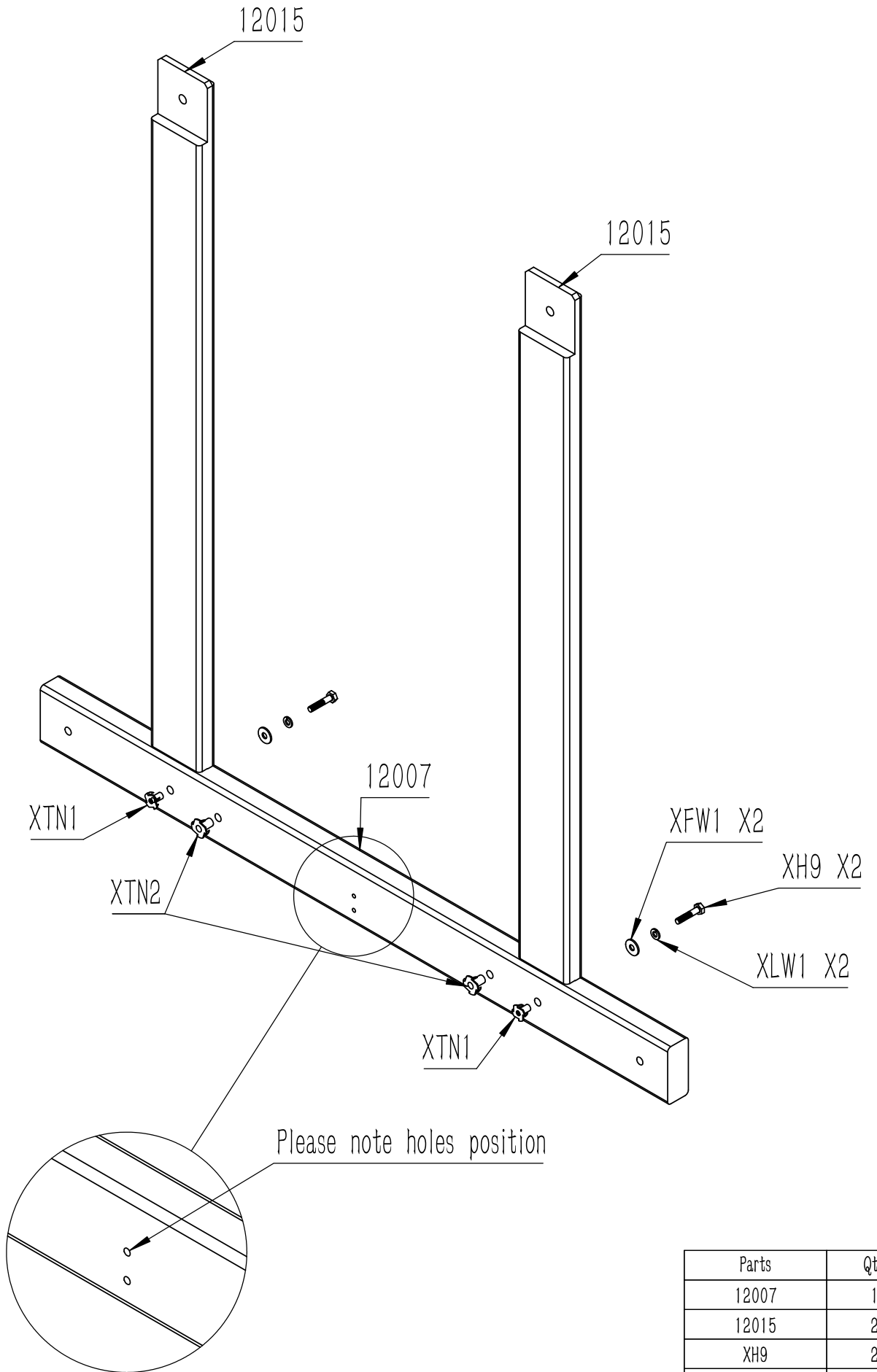

Parts	Qty
12007	1
12015	2
XH9	2
XFW1	2
XLW1	2
XTN1	2
XTN2	2

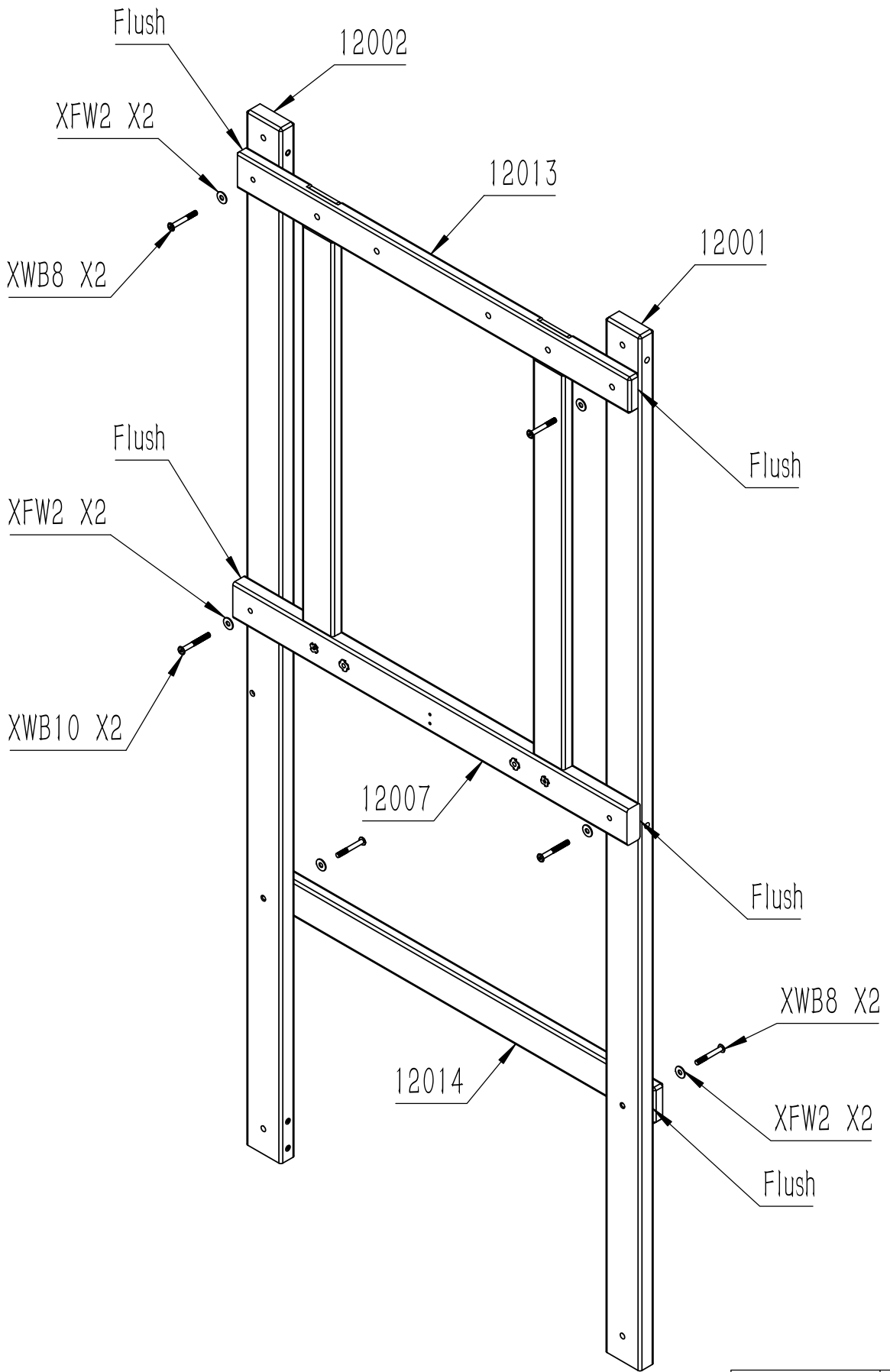

Parts	Qty
12013	1
12014	1
XWB8	4
XWB10	2
XFW2	6

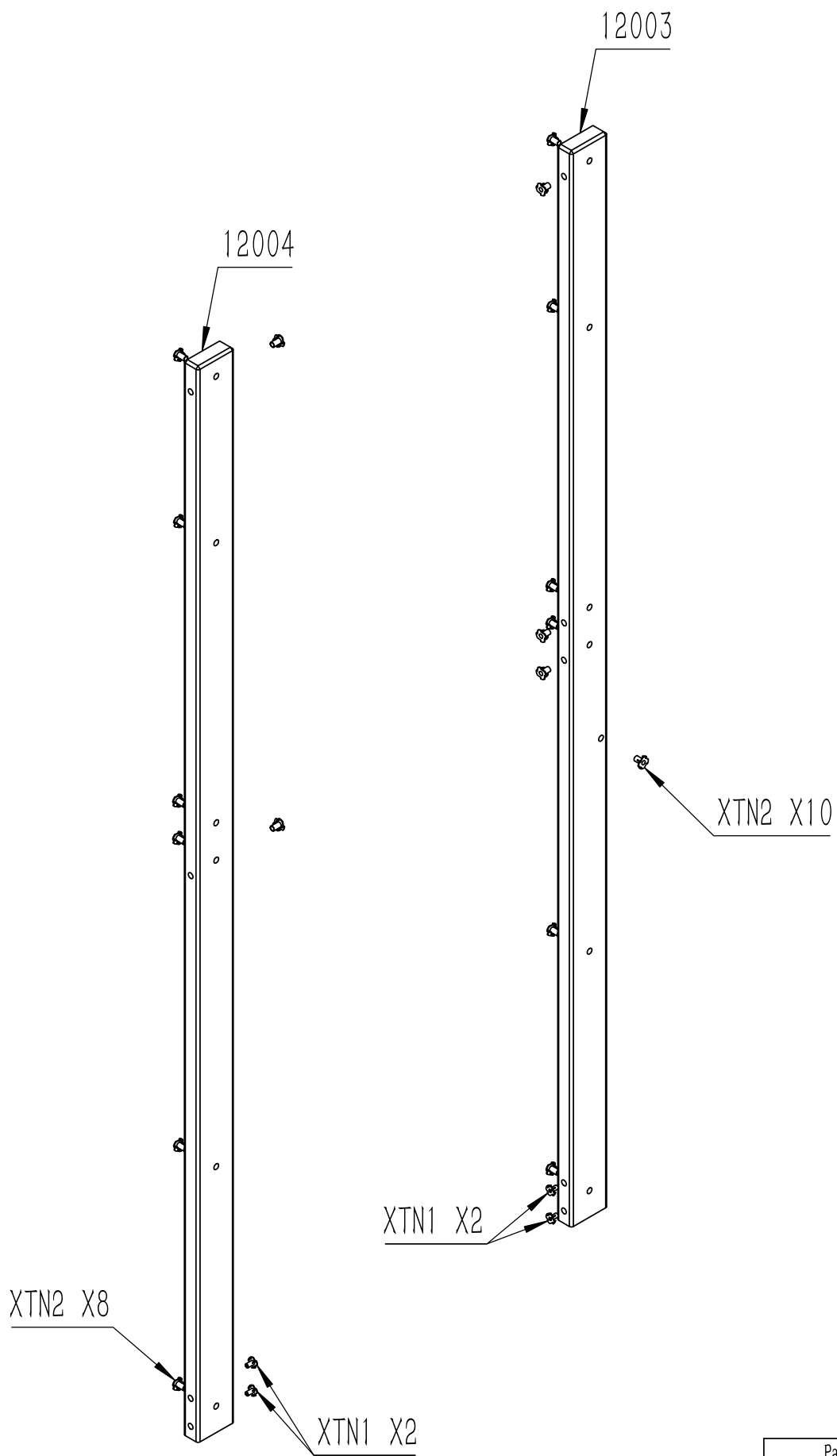

Parts	Qty
12003	1
12004	1
XTN1	4
XTN2	18

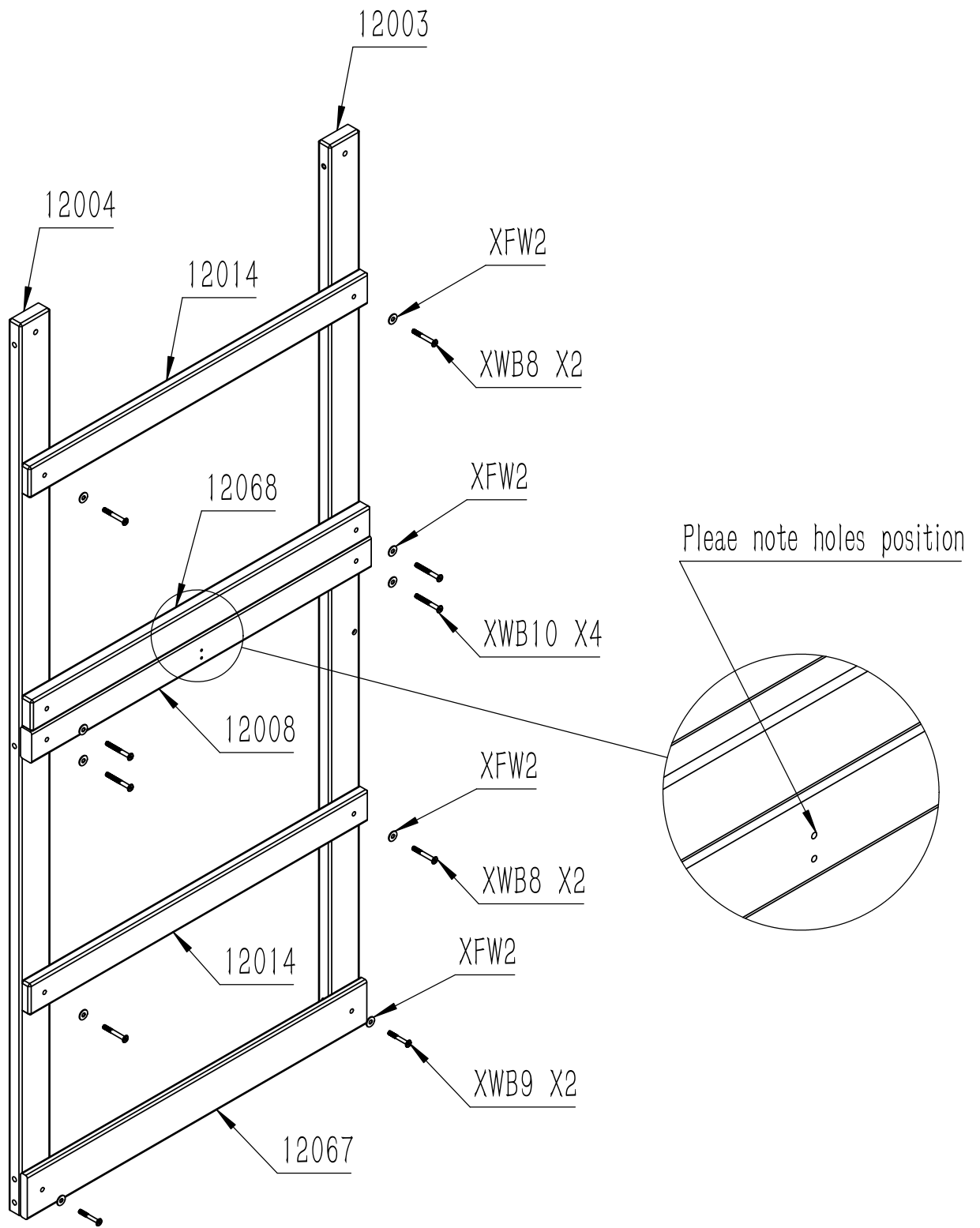

Parts	Qty
12008	1
12014	2
12067	1
12068	1
XWB8	4
XWB9	2
XWB10	4
XFW2	10

Please note holes position

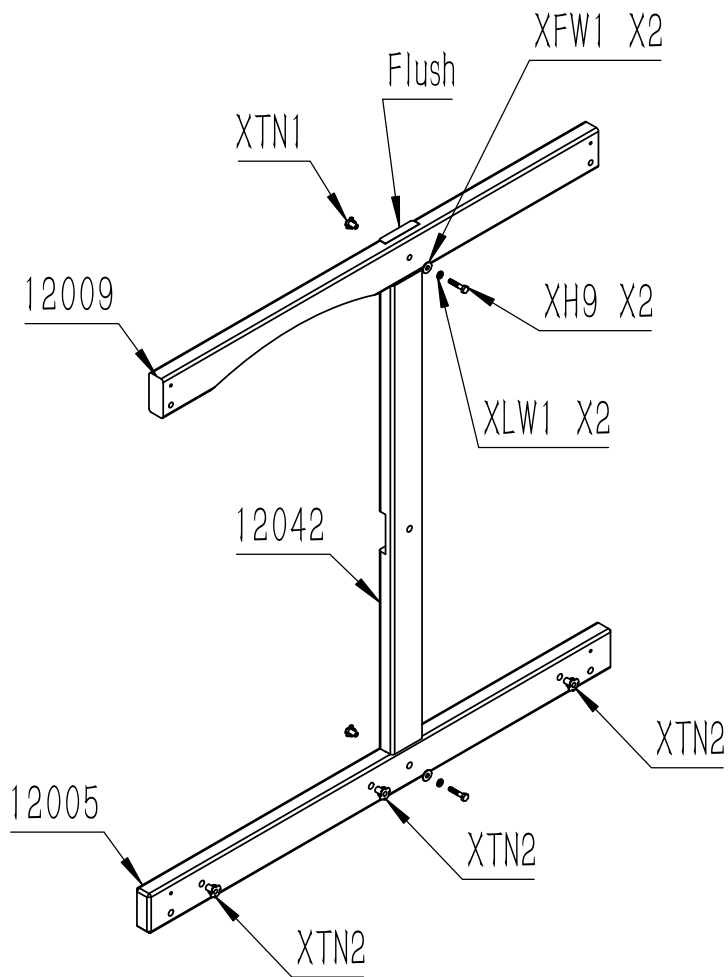
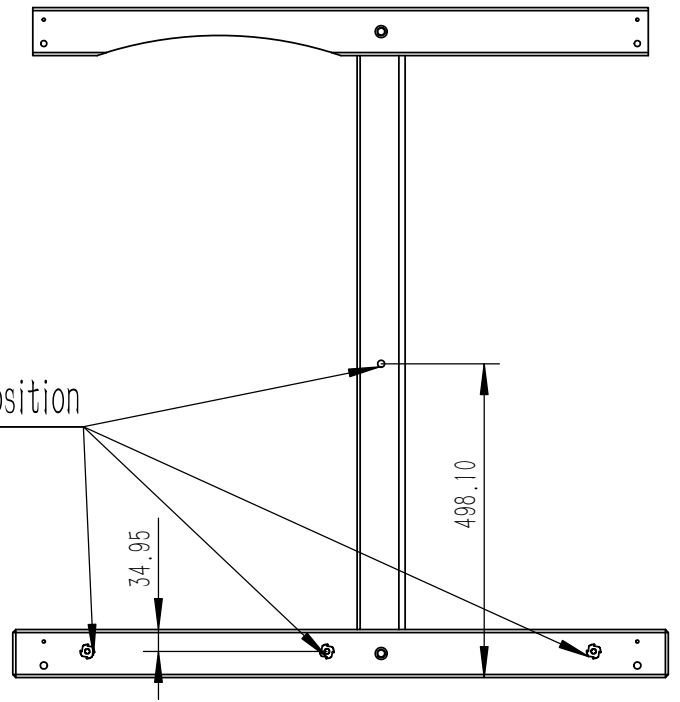

Parts	Qty
12005	1
12009	1
12042	1
XH9	2
XFW1	2
XLW1	2
XTN1	2
XTN2	3

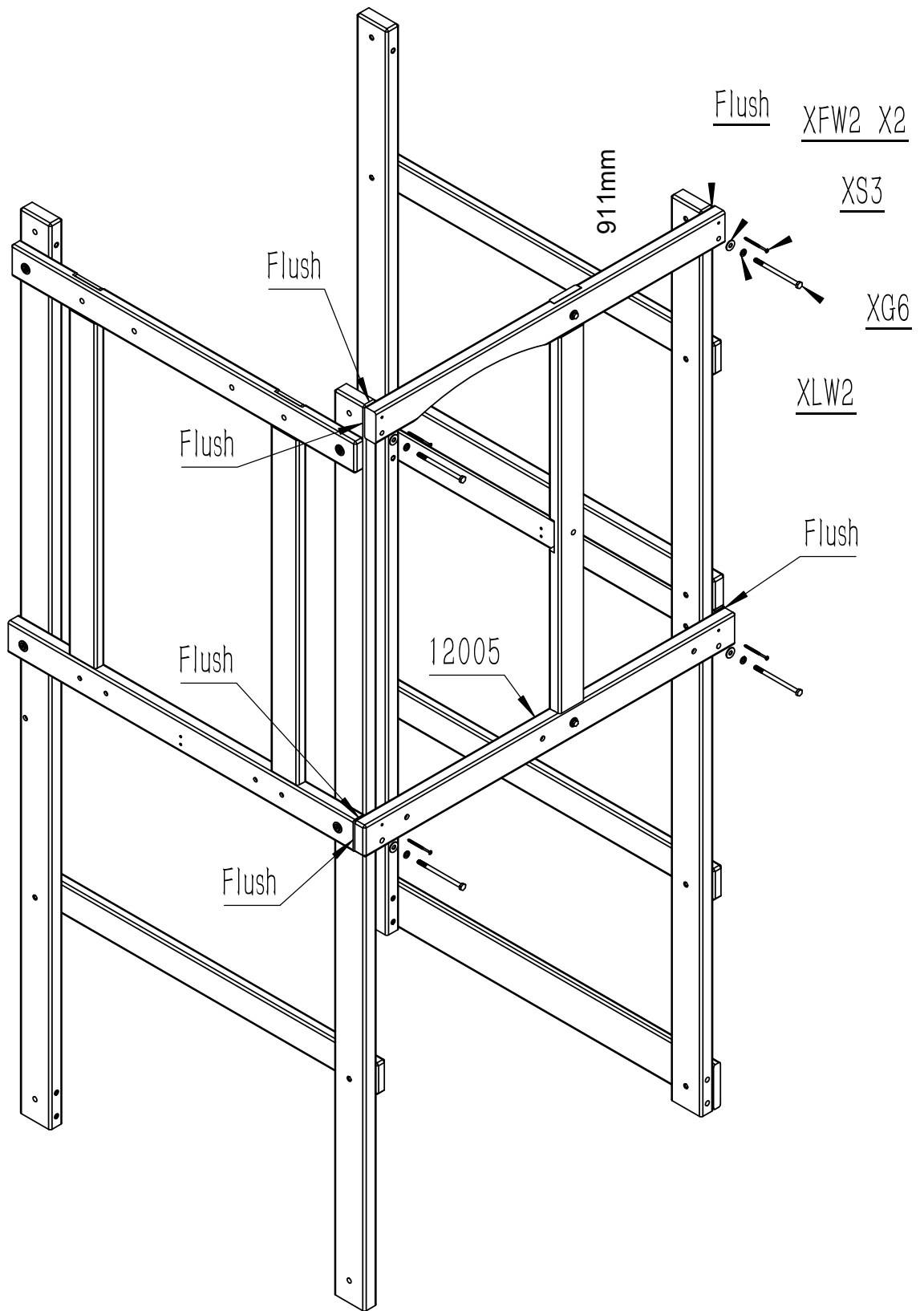

Parts	Qty
XG6	4
XFW2	8
XLW2	4
XS3	4

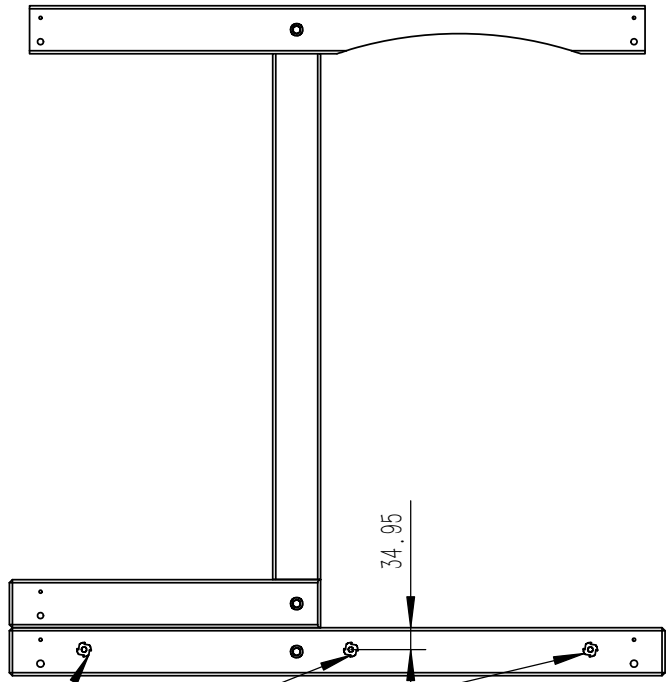

Please note holes position

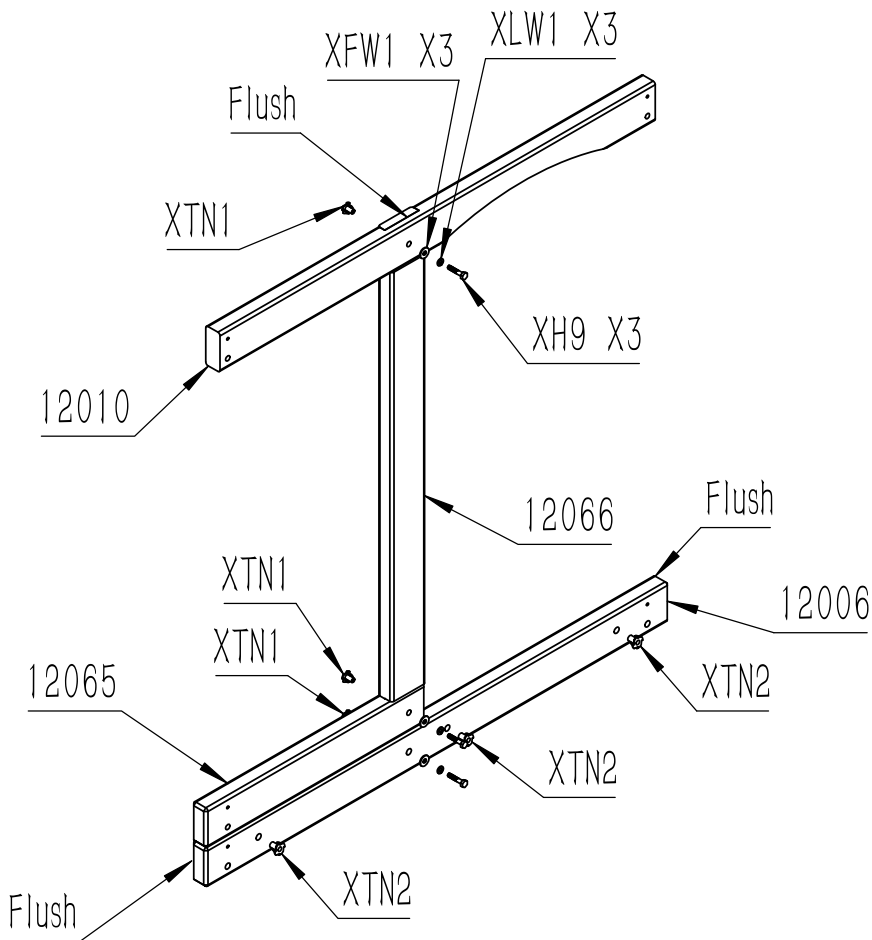

Parts	Qty
12006	1
12010	1
12065	1
12066	1
XH9	3
XLW1	3
XFW1	3
XTN1	3
XTN2	3

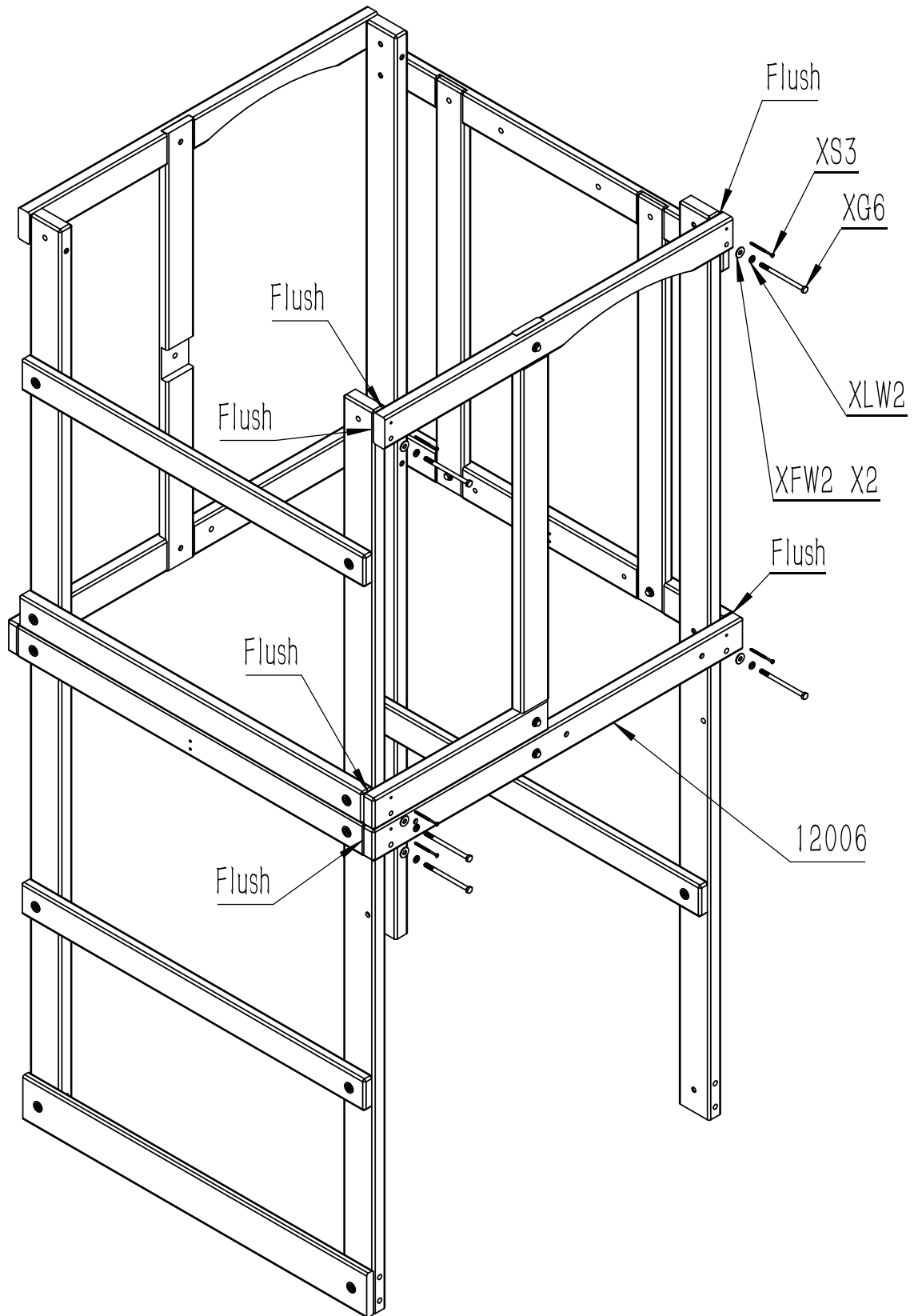

Parts	Qty
XG6	5
XLW2	10
XFW2	5
XS3	5

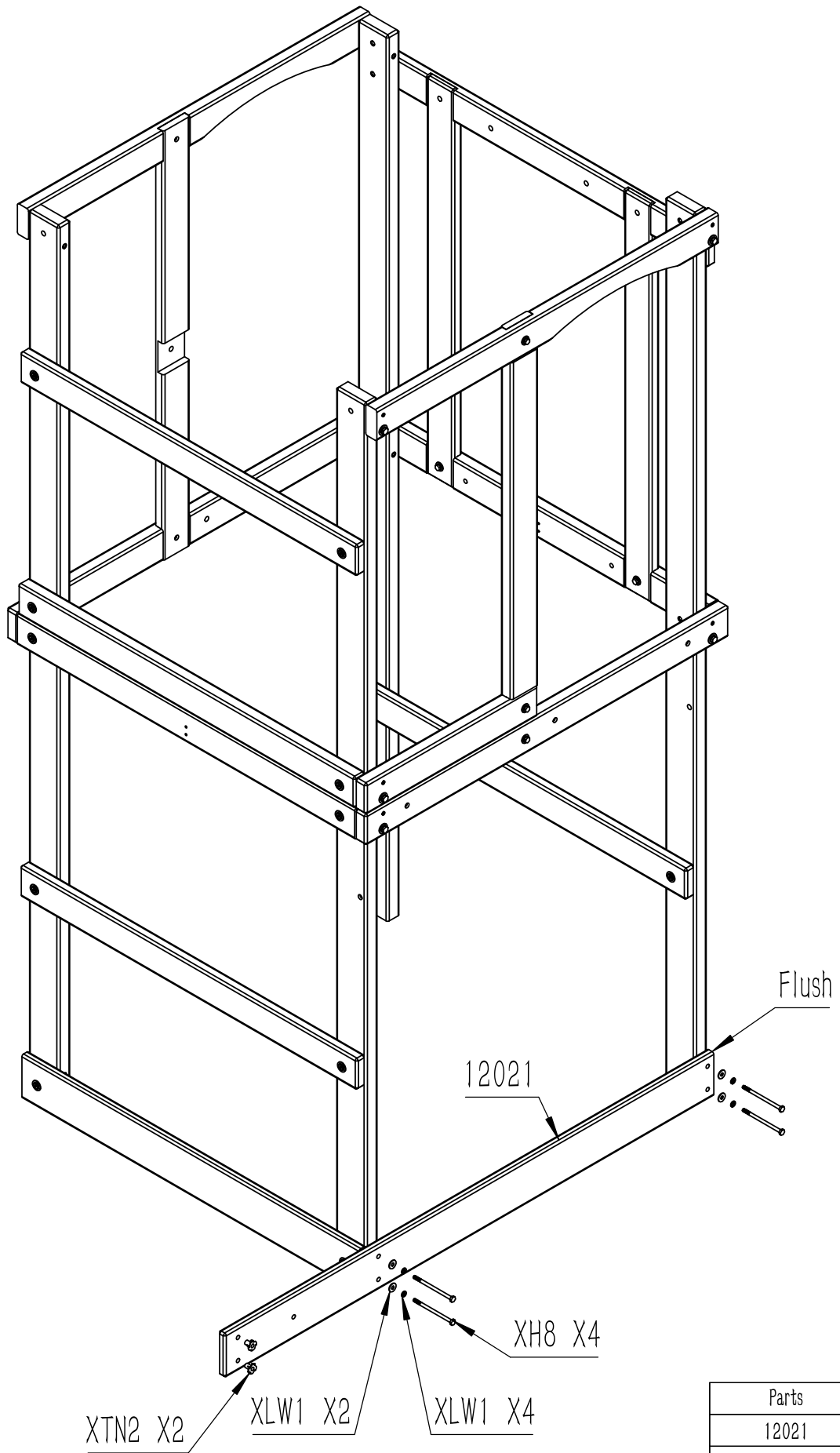

Parts	Qty
12021	1
XH8	4
XLW1	4
XFW1	4
XTN2	2

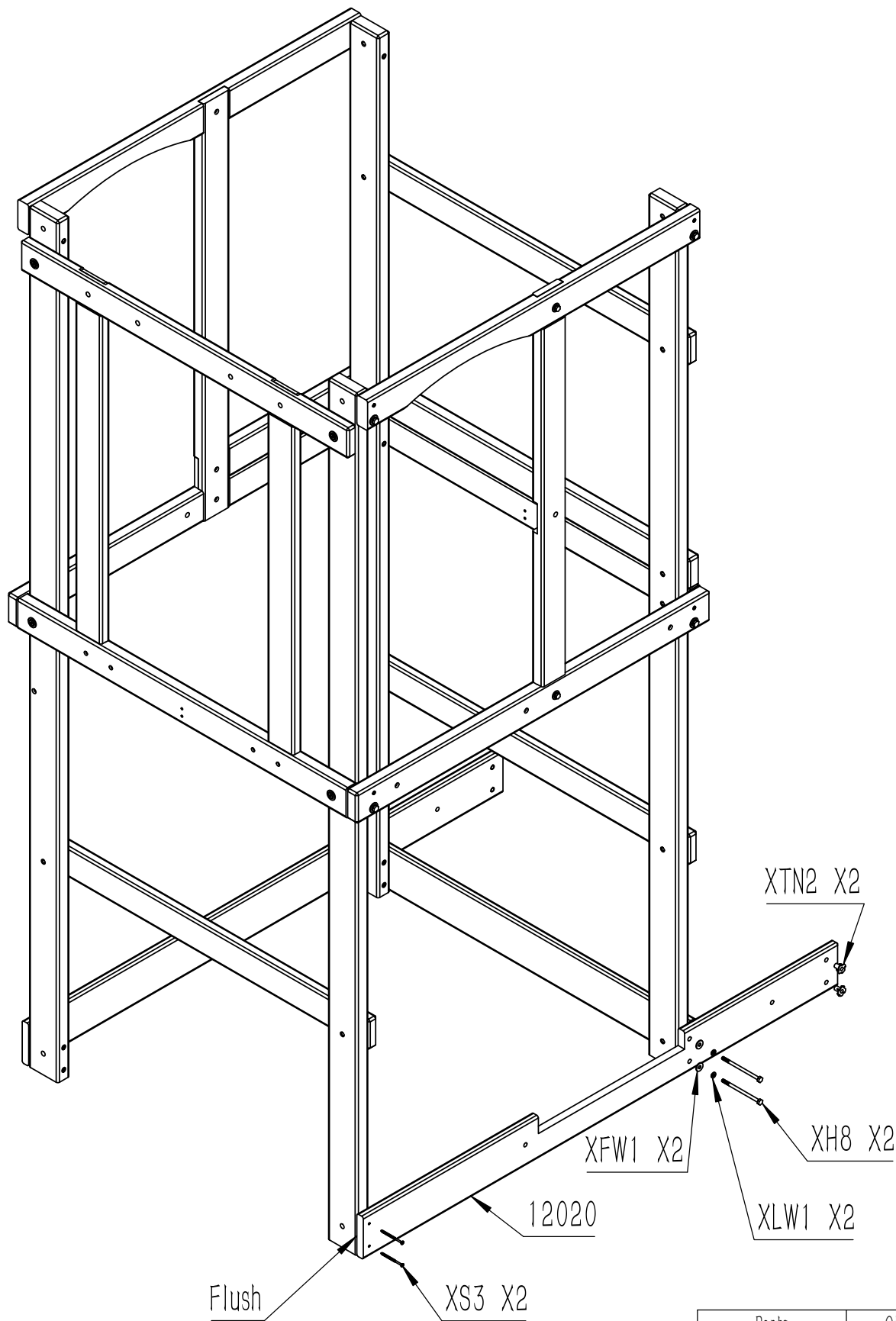

Parts	Qty
12020	1
XH8	2
XLW1	2
XFW1	2
XS3	2
XTN2	2

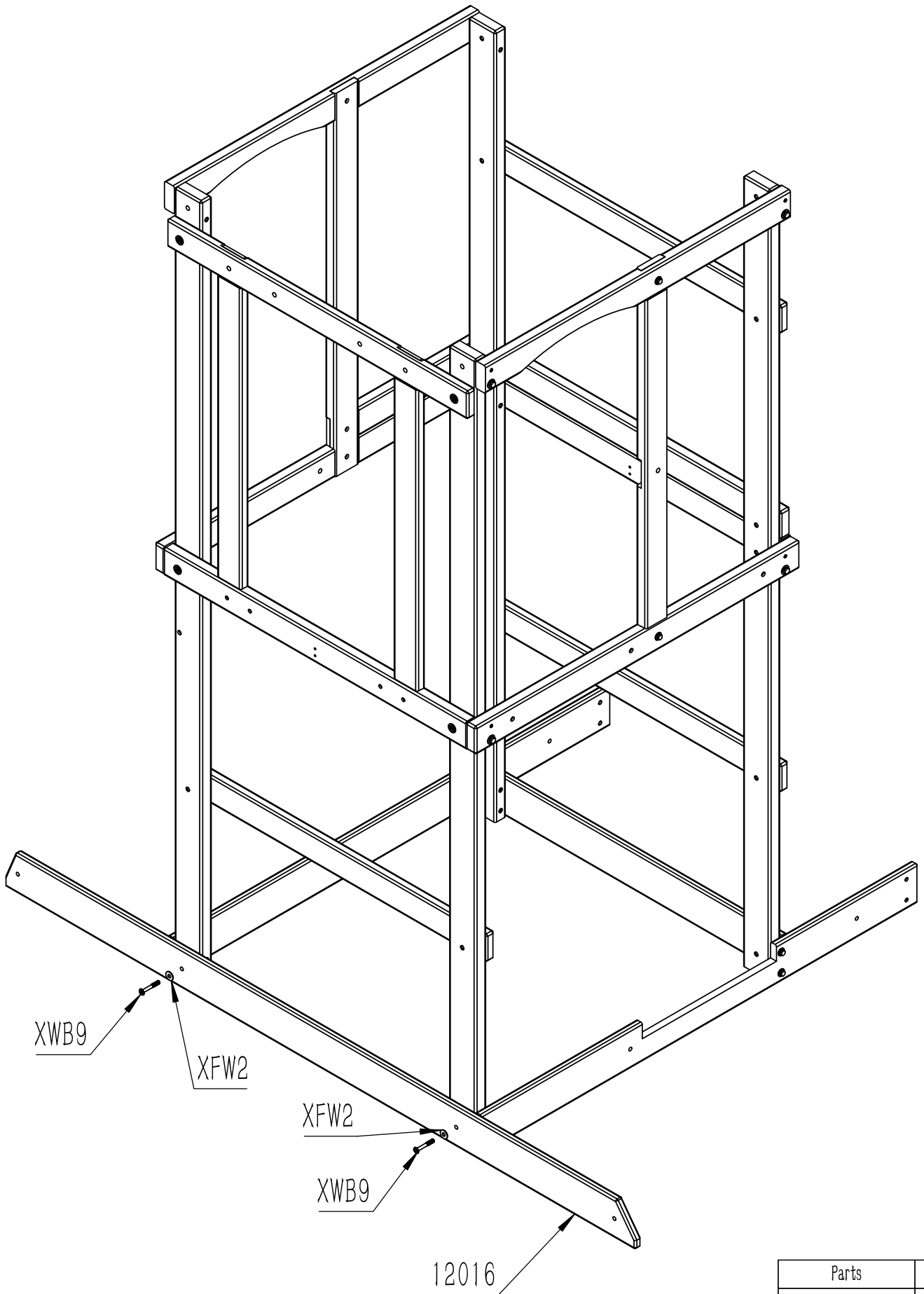

Parts	Qty
12016	1
XWB9	2
XFW2	2

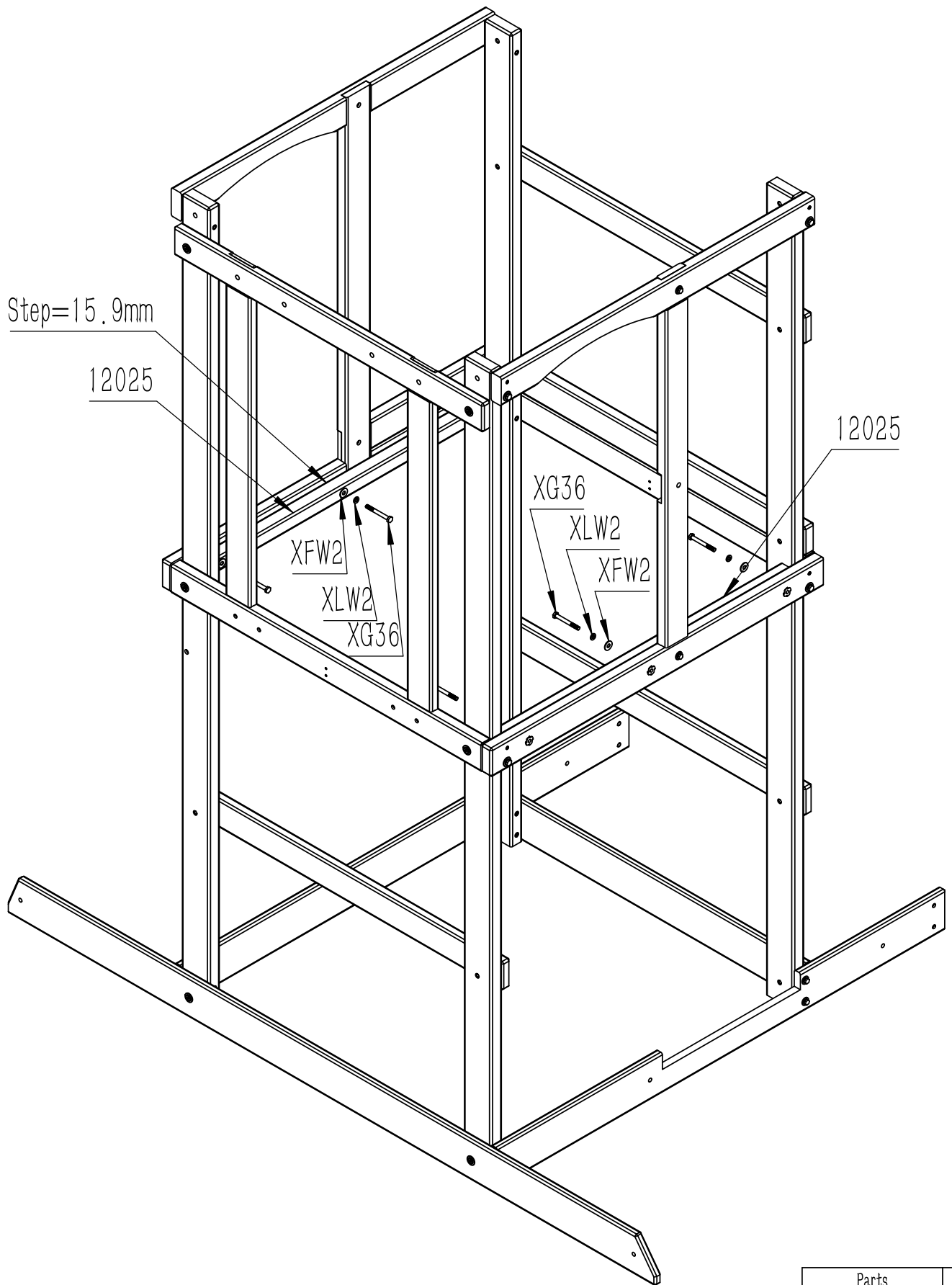

Parts	Qty
12025	2
XG36	6
XFW2	6
XLW2	6

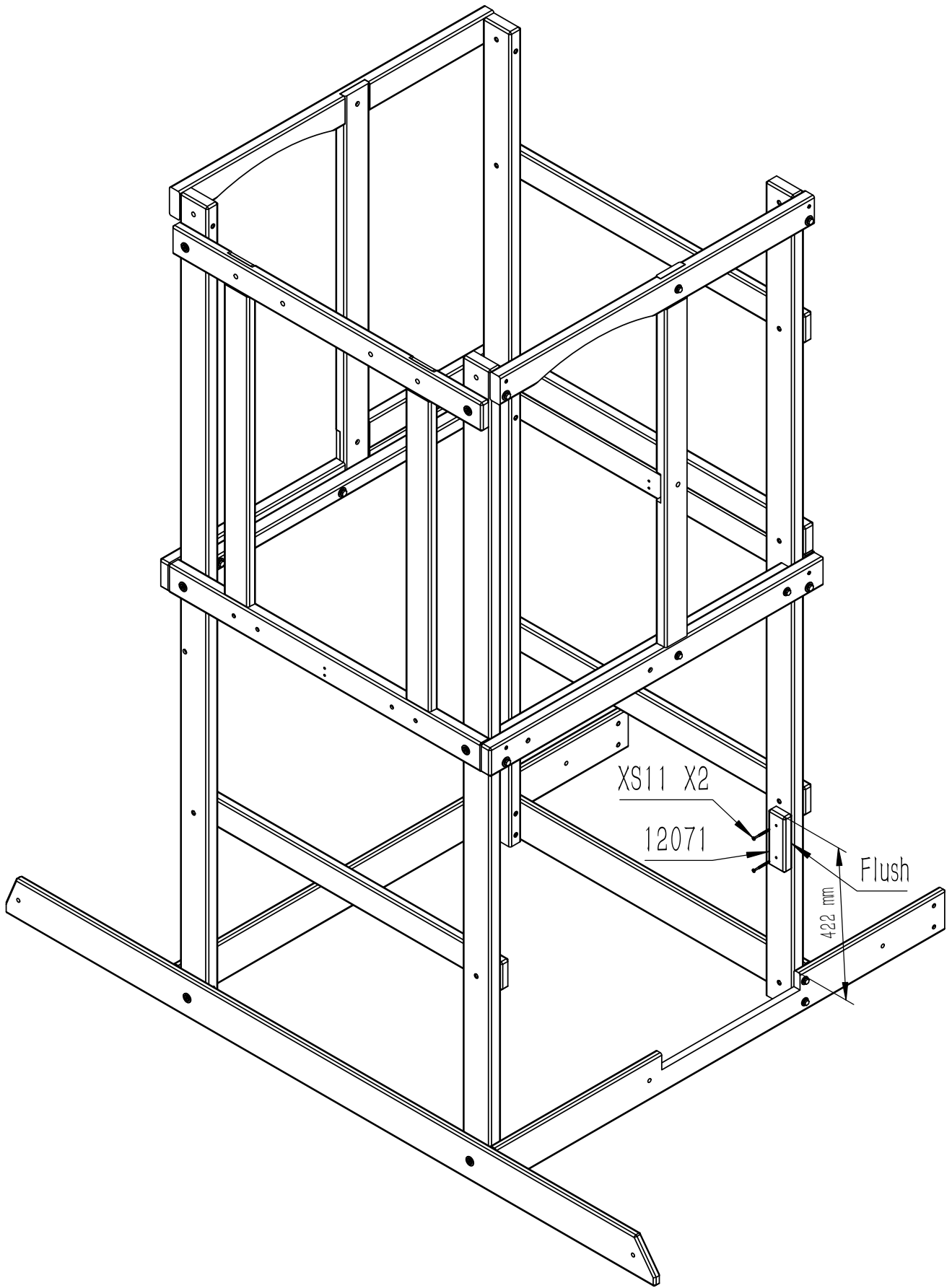

Parts	Qty
12071	1
XS11	2

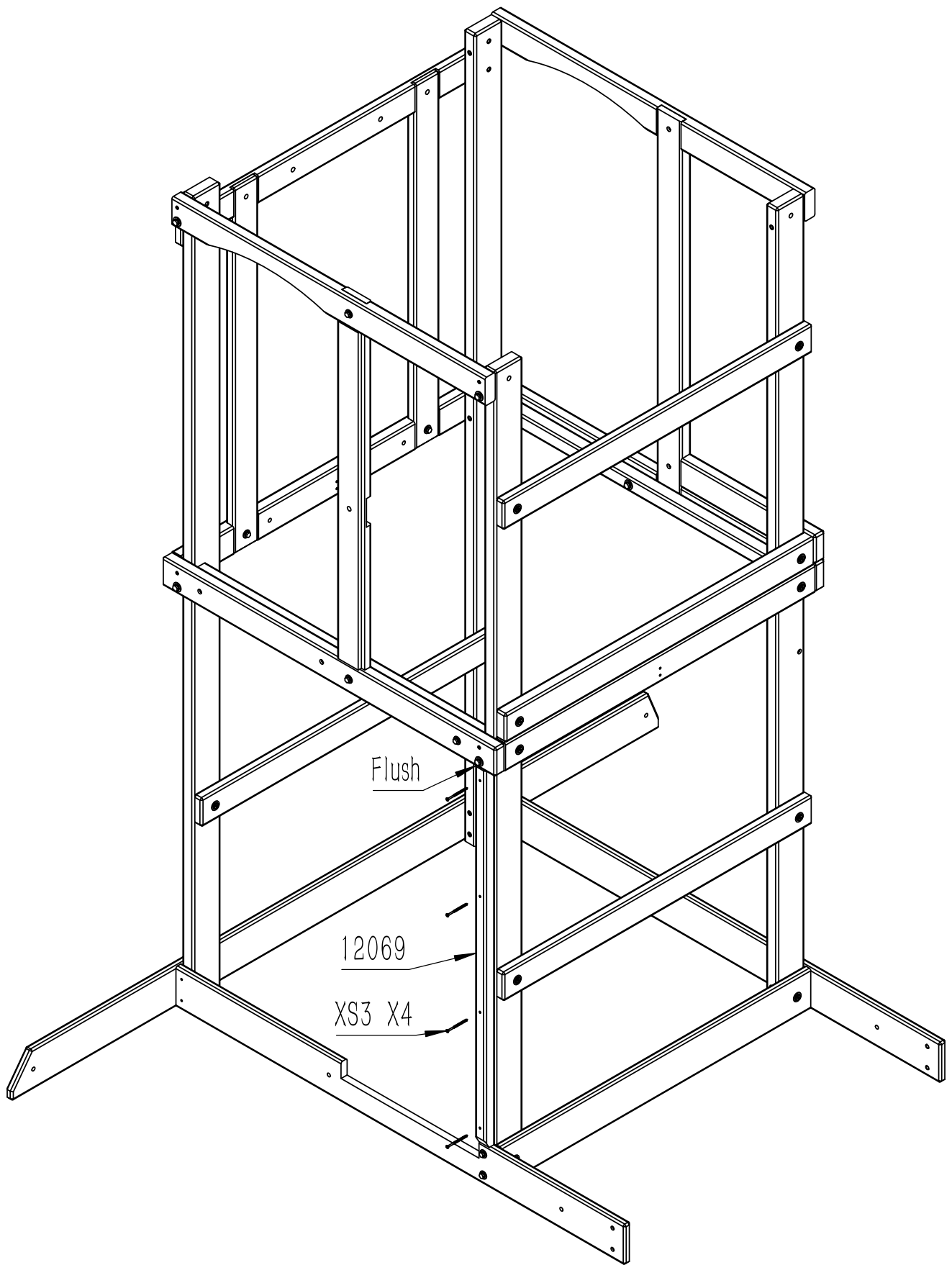

Parts	Qty
12069	1
XS3	4

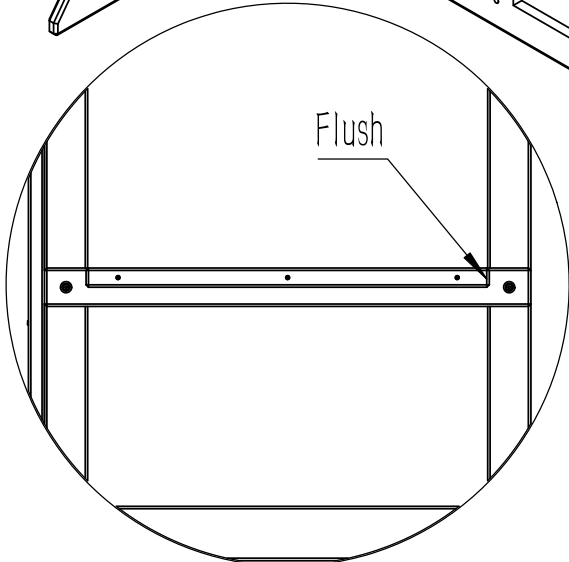
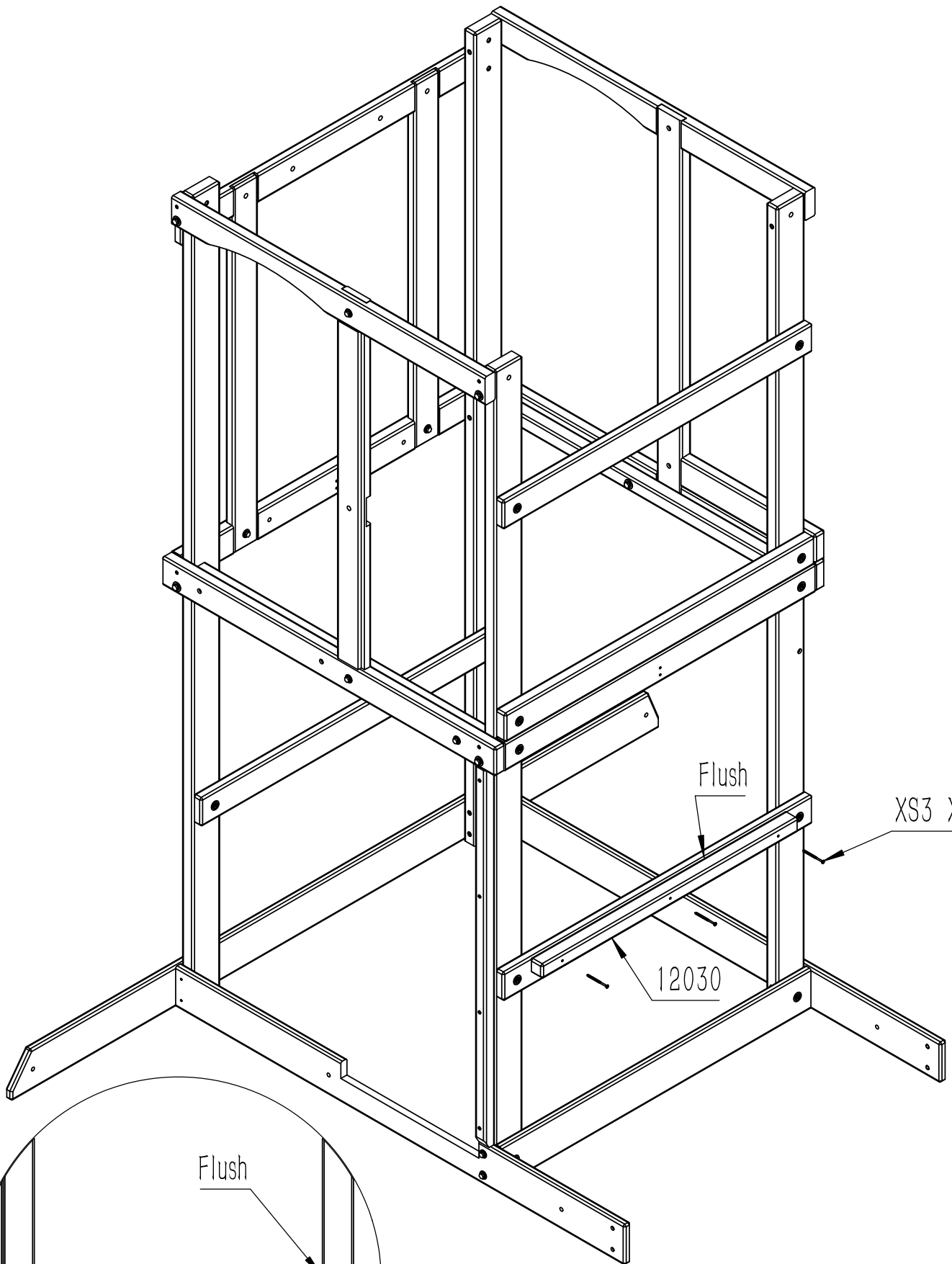

Parts	Qty
12030	1
XS3	3

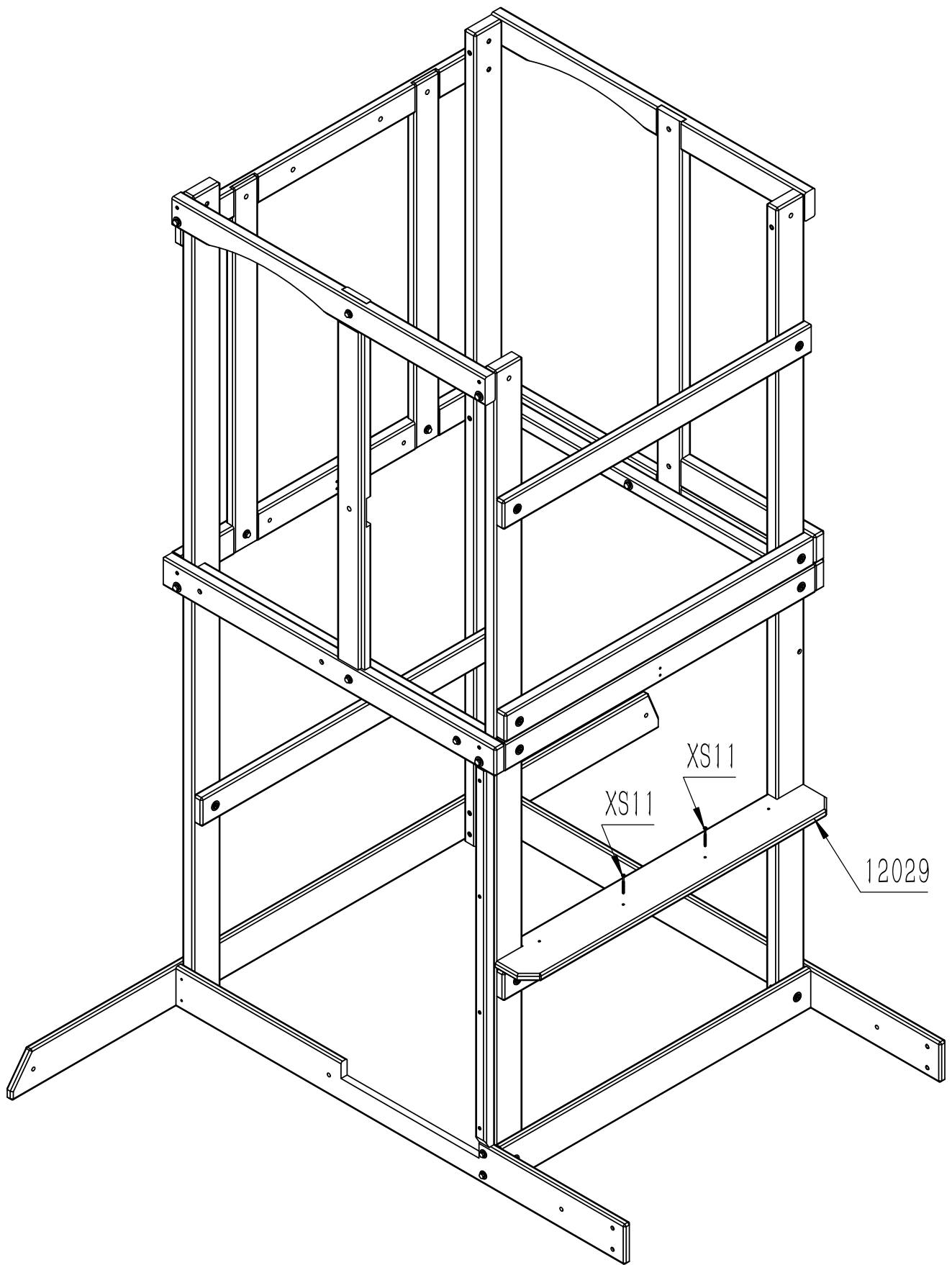

Parts	Qty
12029	1
XS11	2

Pre-drill each hole using a 1/8" drill bit for XS1

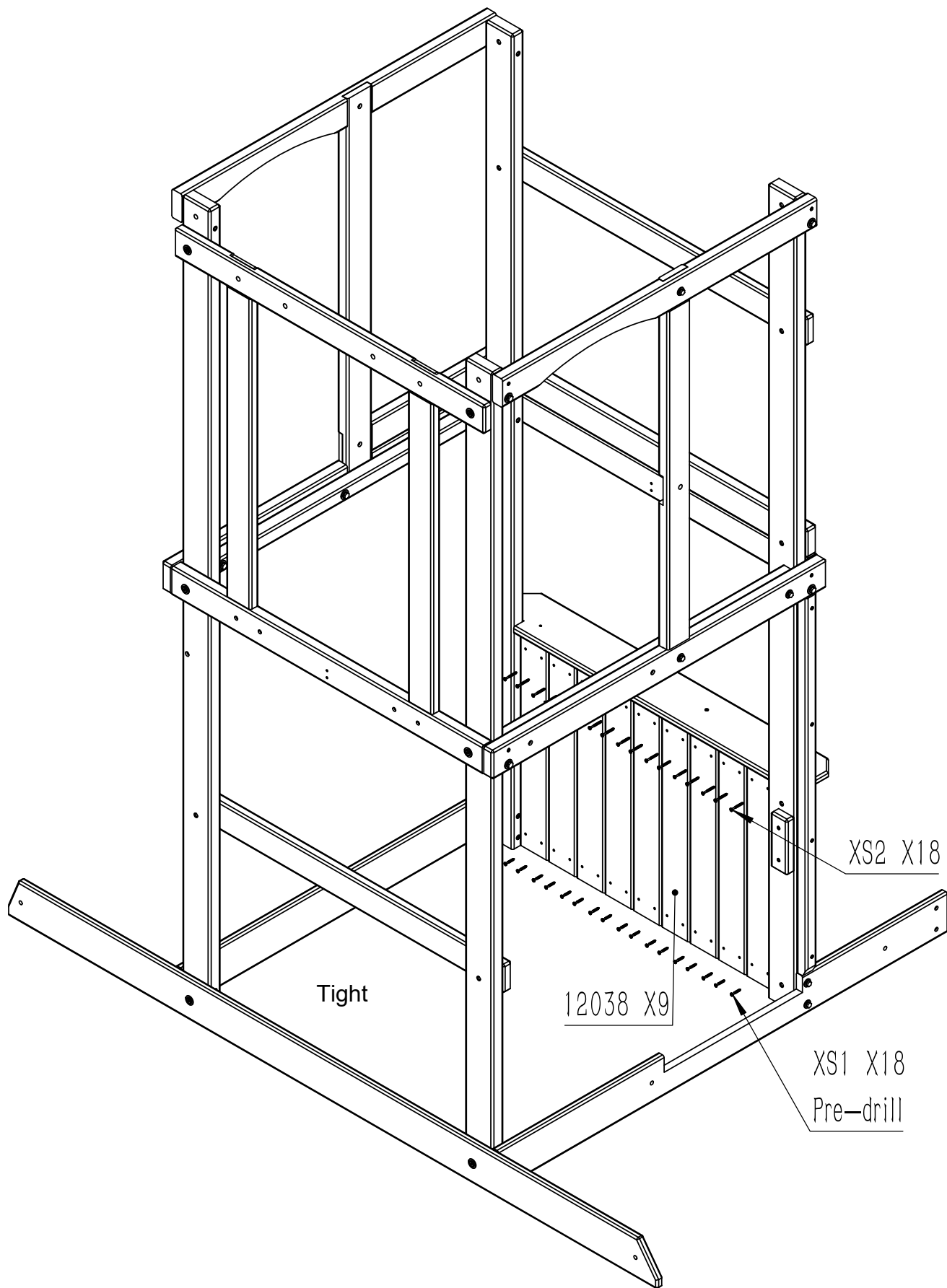

Parts	Qty
12038	9
XS2	18
XS1	18

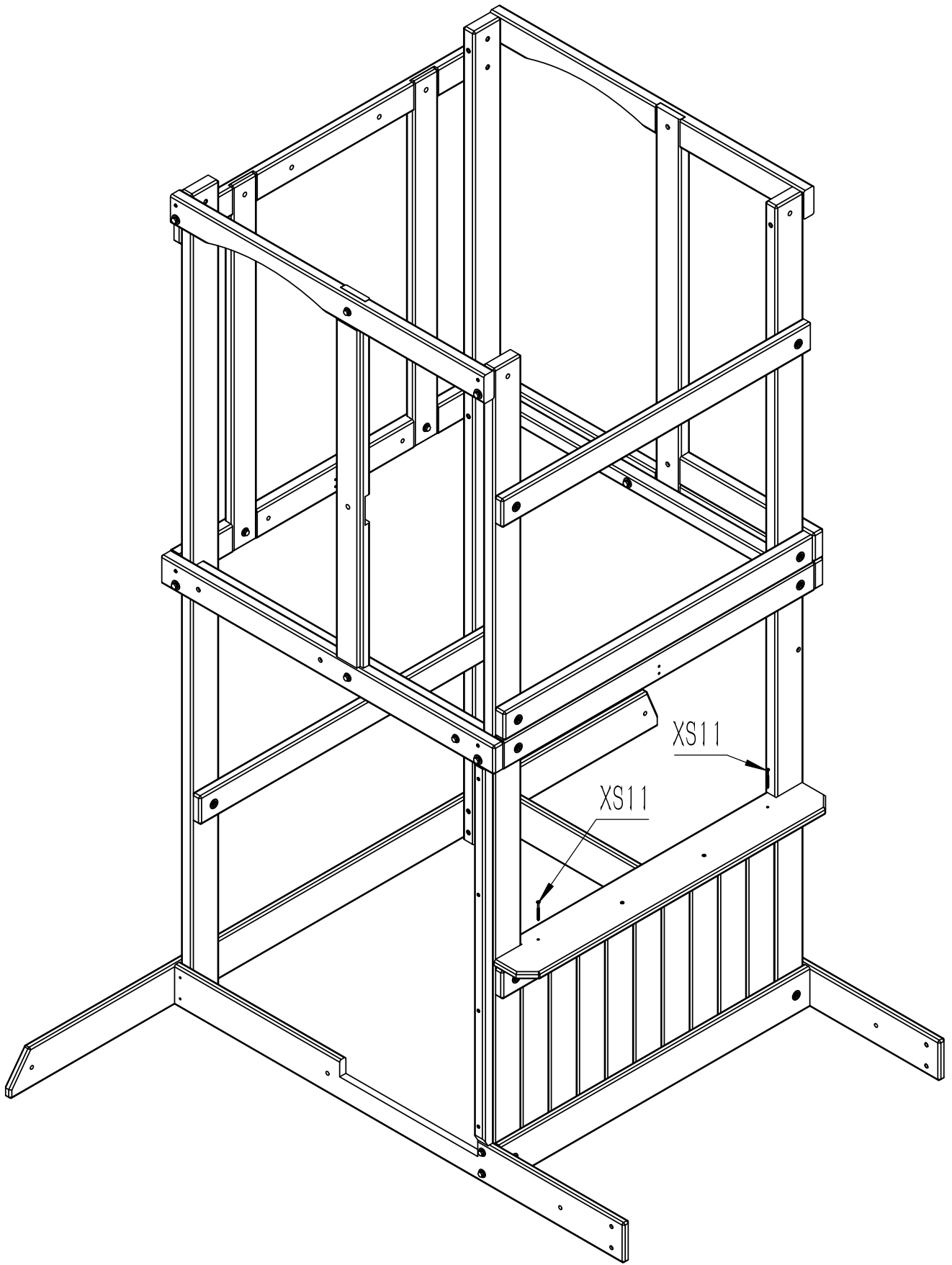

Parts	Qty
XS11	2

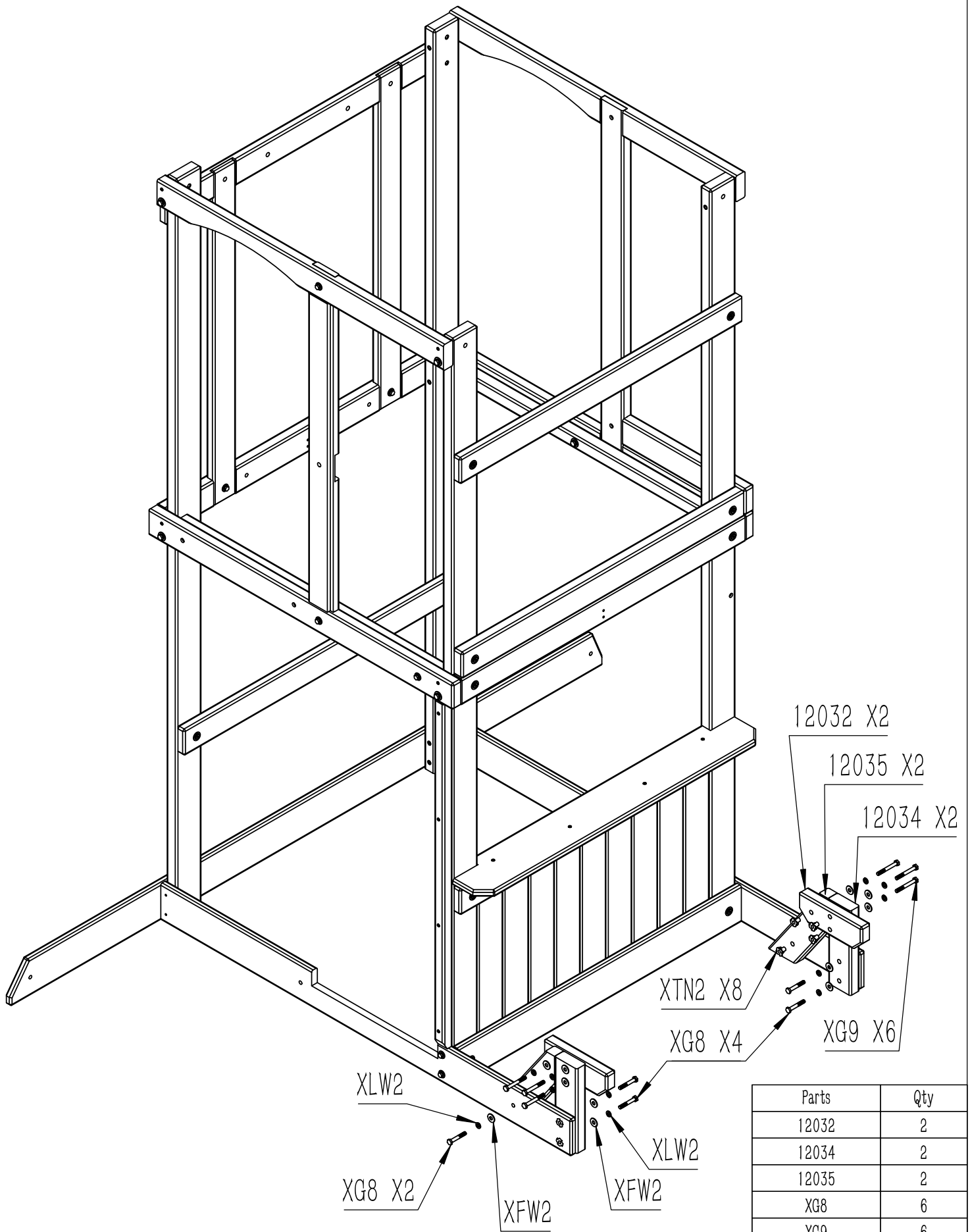

Parts	Qty
12032	2
12034	2
12035	2
XG8	6
XG9	6
XLW2	12
XFW2	12
XTN2	8

Pre-drill 2 holes using a 1/8" drill bit for XS11

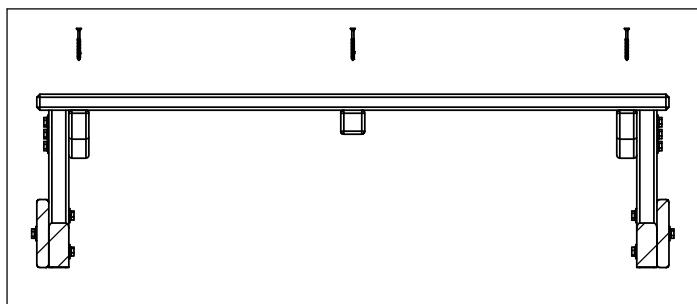
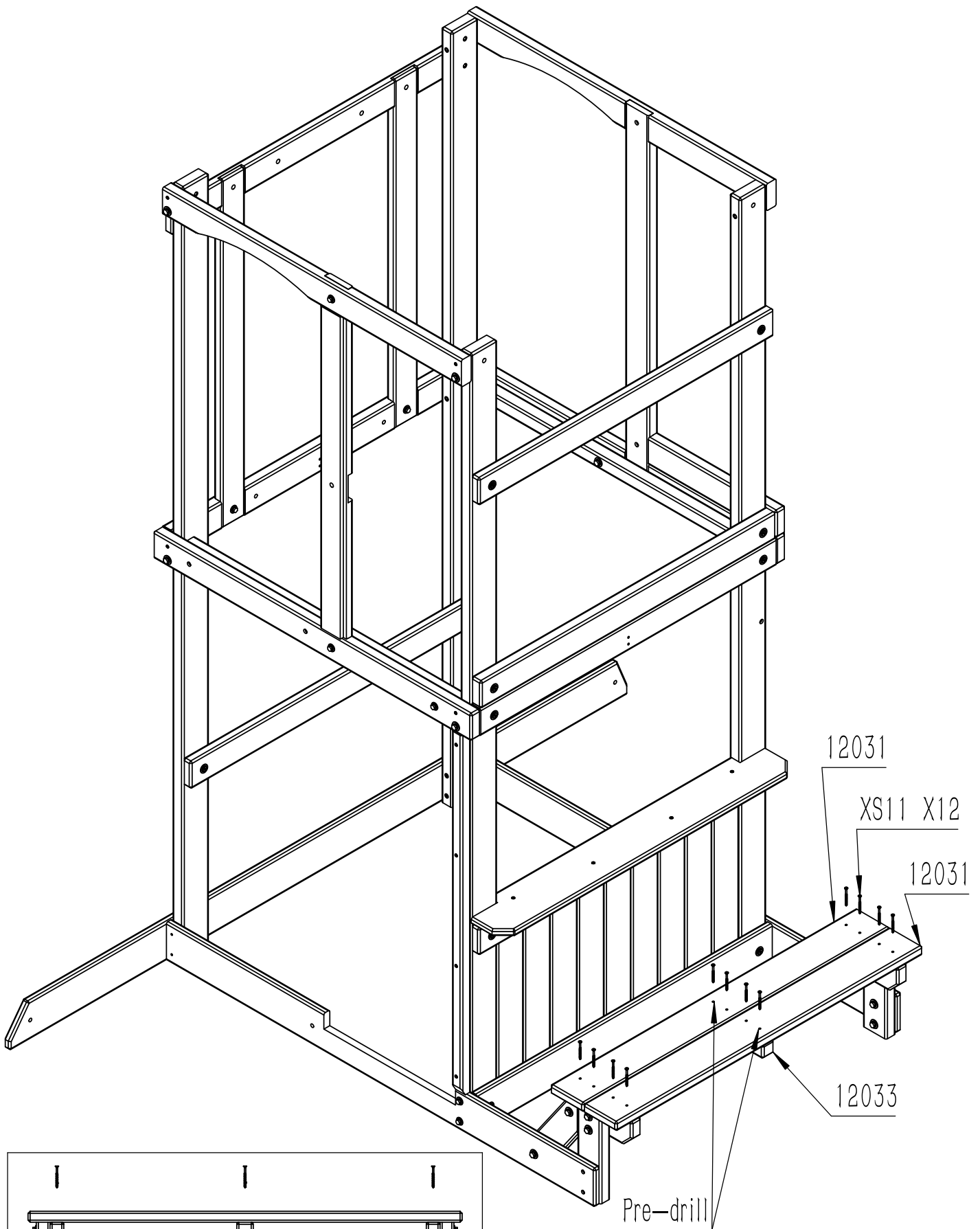

Parts	Qty
12031	2
12033	1
XS11	12

Keep part 12026 in the center of the floor

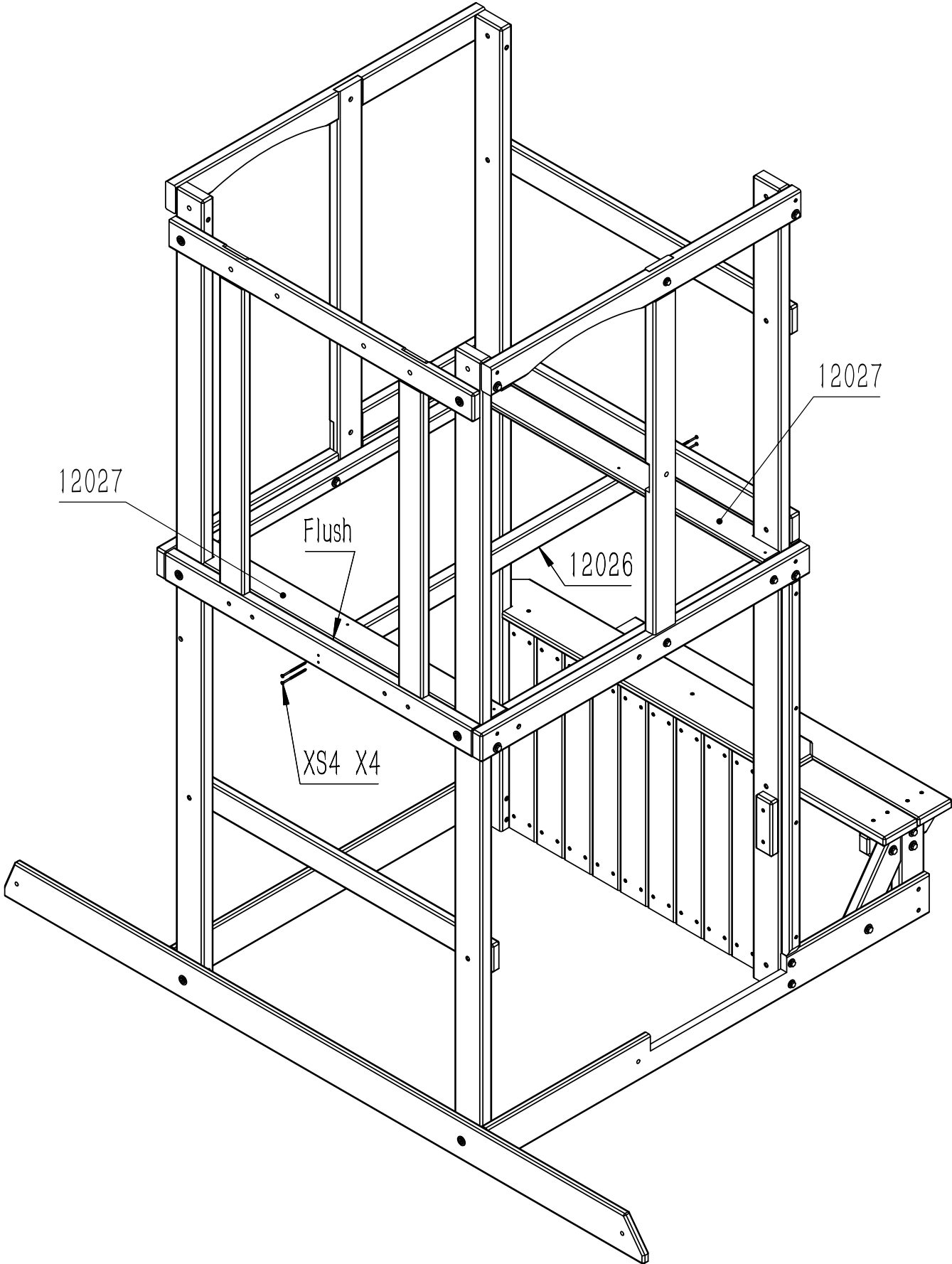

Parts	Qty
12026	1
XS4	4

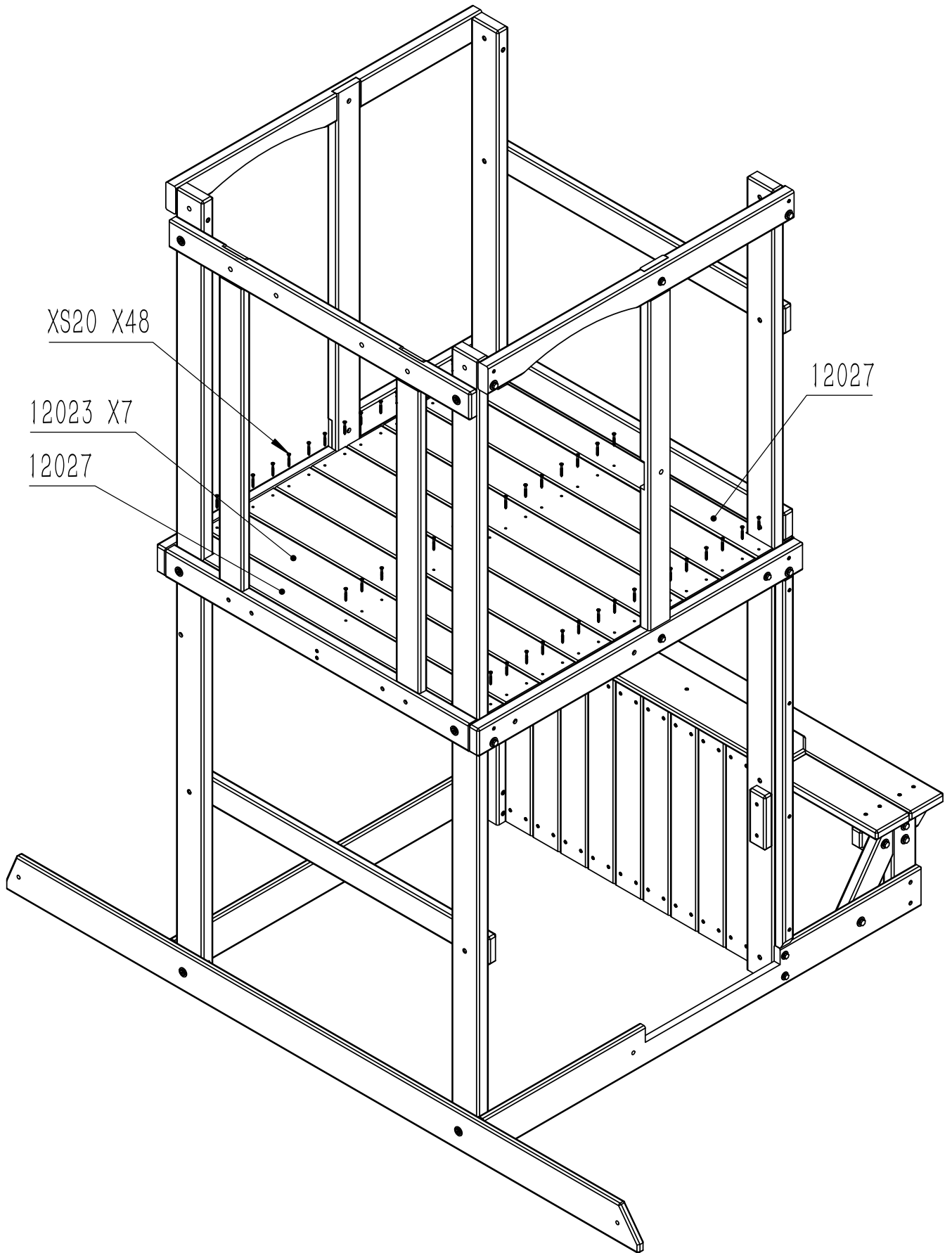

Parts	Qty
12023	7
12027	2
XS20	48

Pre-drill each hole using a 1/8" drill bit for XWL5

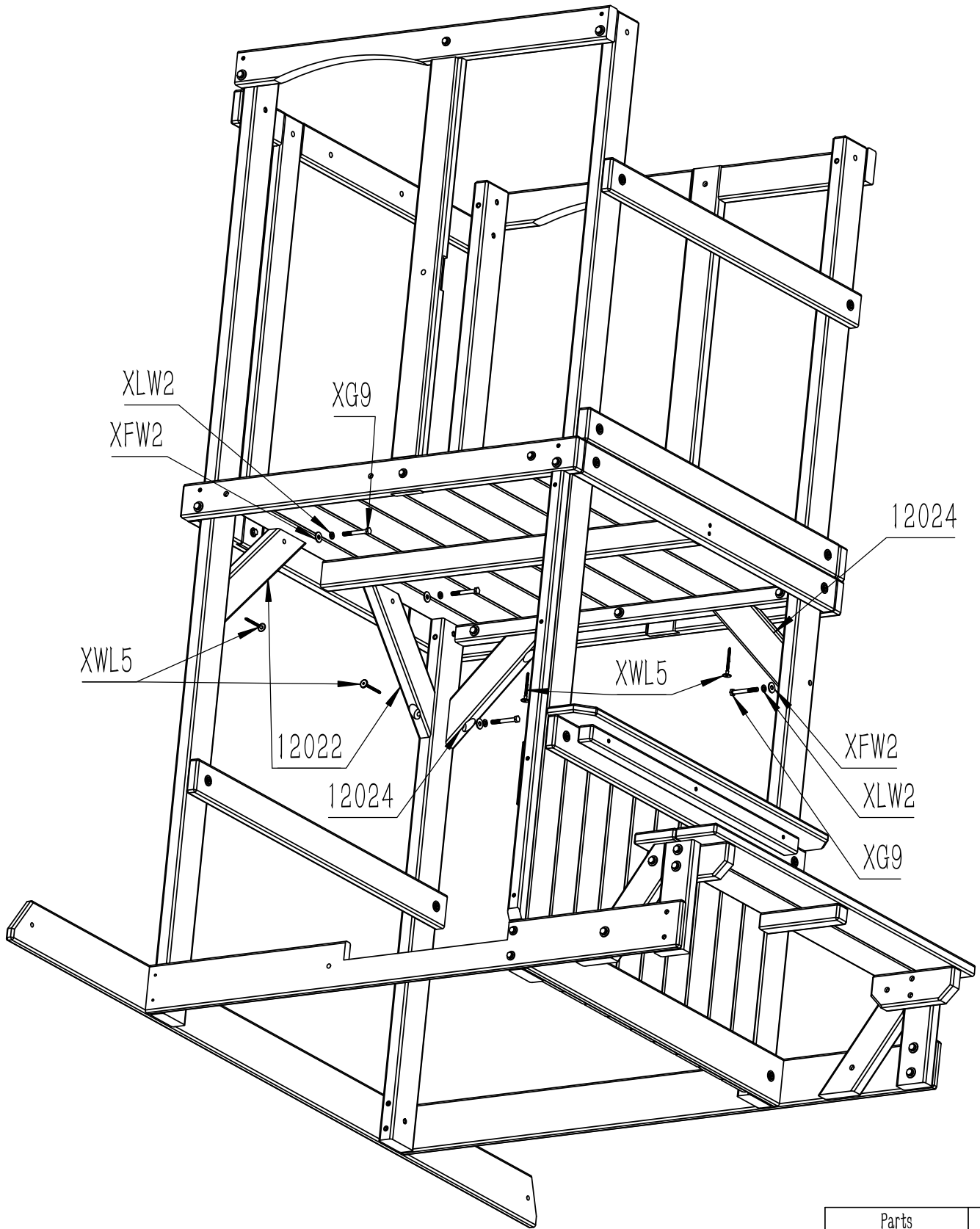

Parts	Qty
12022	2
12024	2
XG9	4
XLW2	4
XFW2	4
XWL5	4

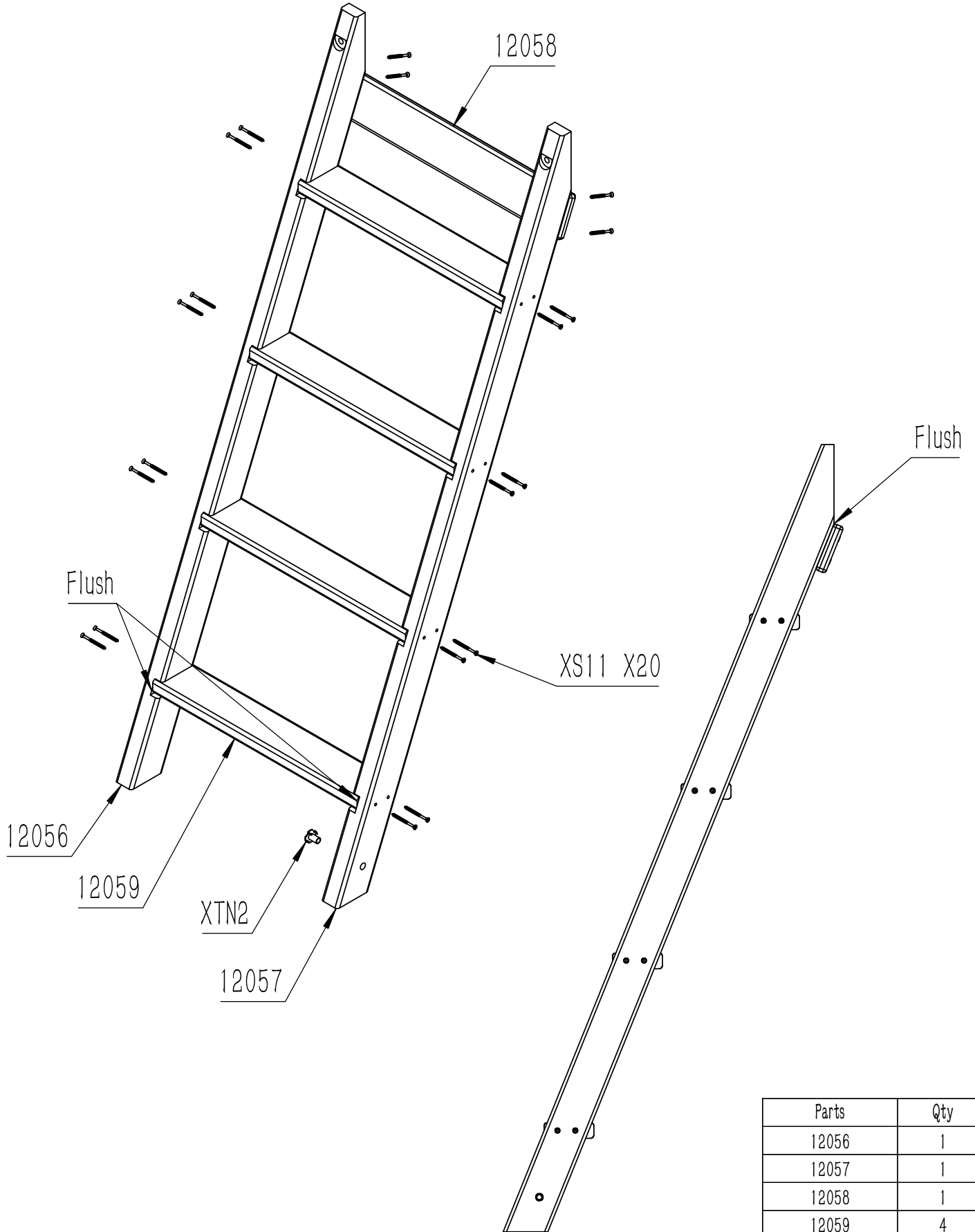

Parts	Qty
12056	1
12057	1
12058	1
12059	4
XTN2	1
XS11	20

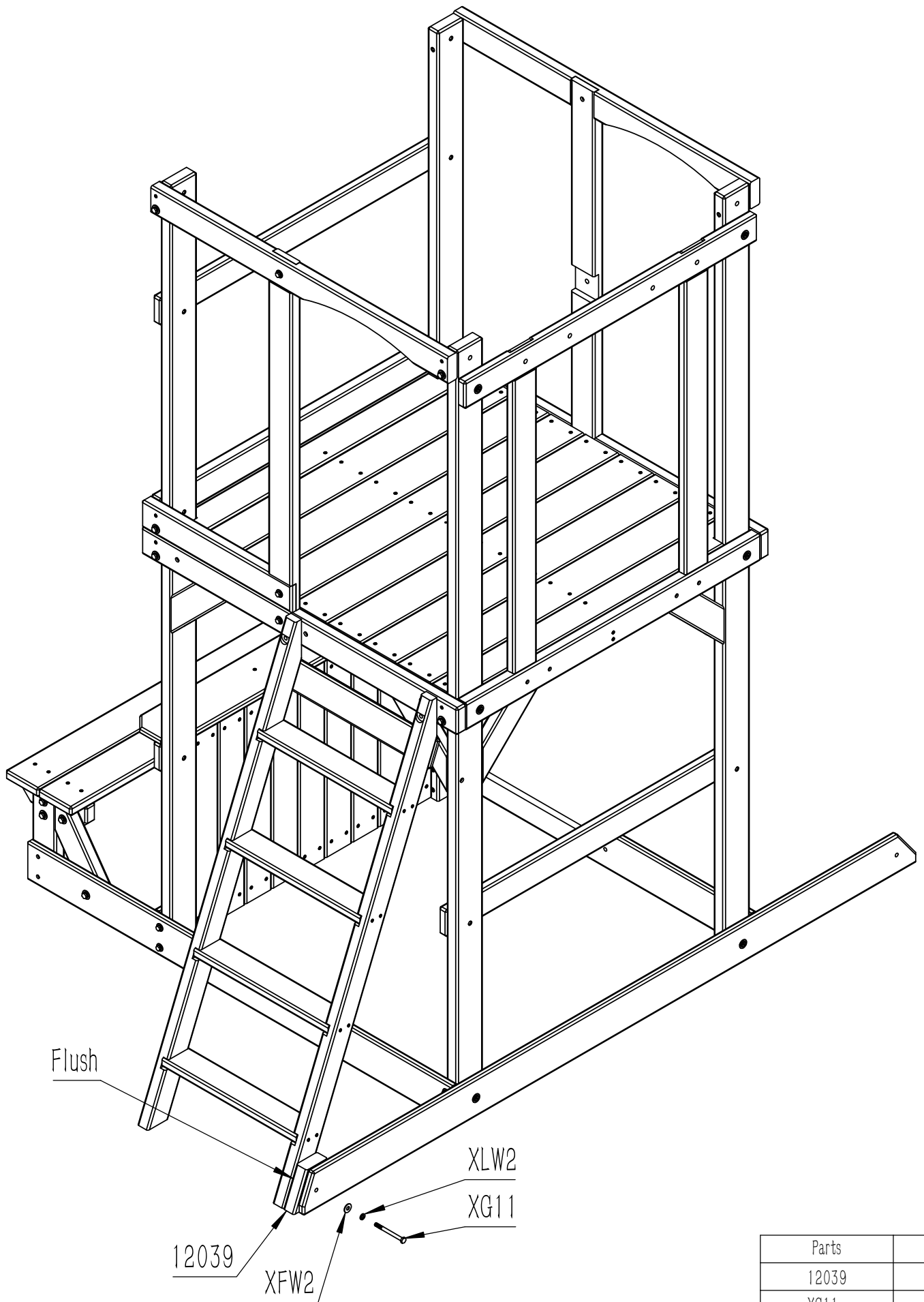

Parts	Qty
12039	1
XG11	1
XFW2	1
XLW2	1

Pre-drill each hole using a 1/8" drill bit for XWL5

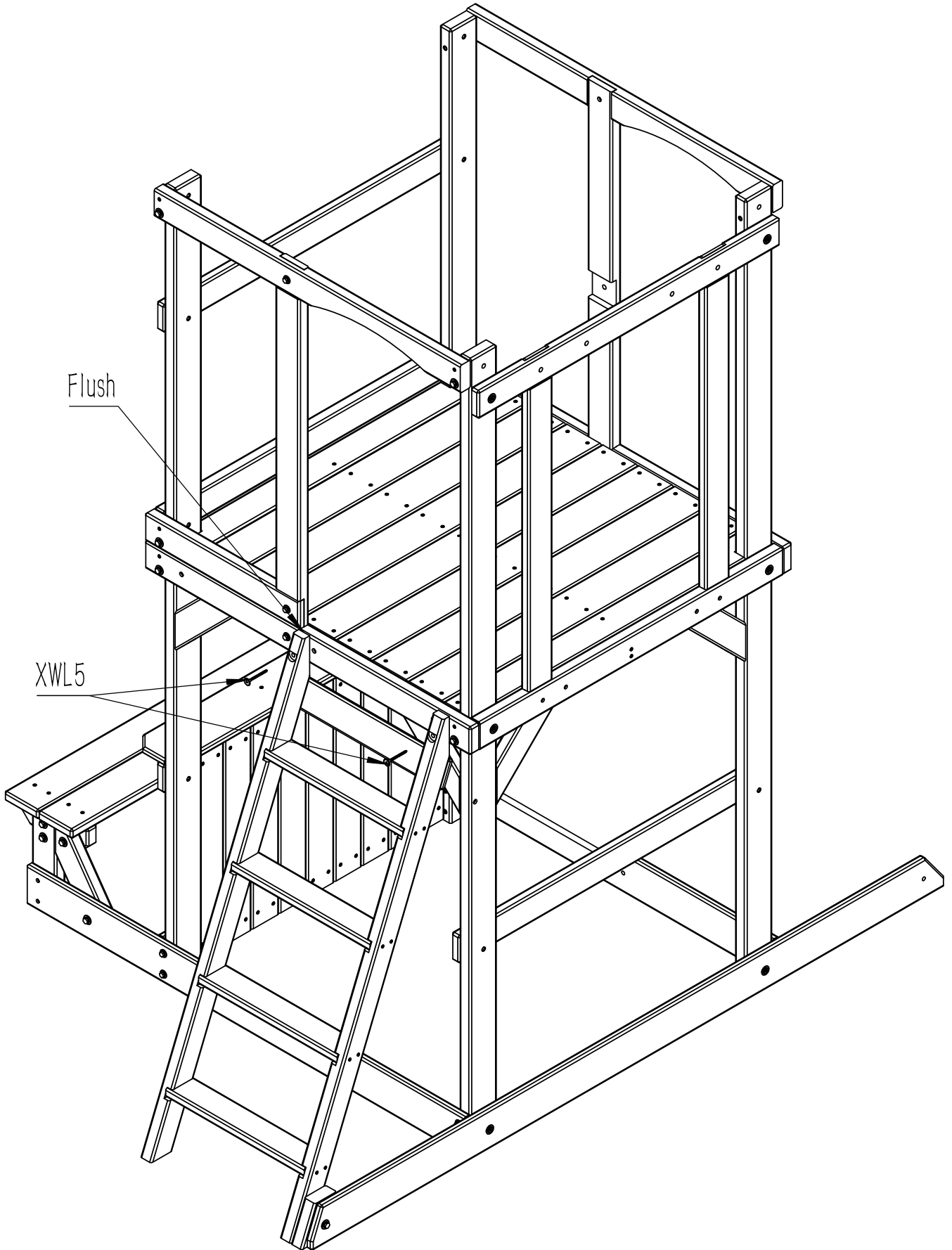

Parts	Qty
XWL5	2

Pre-drill each hole using a 1/8" drill bit for XWL3

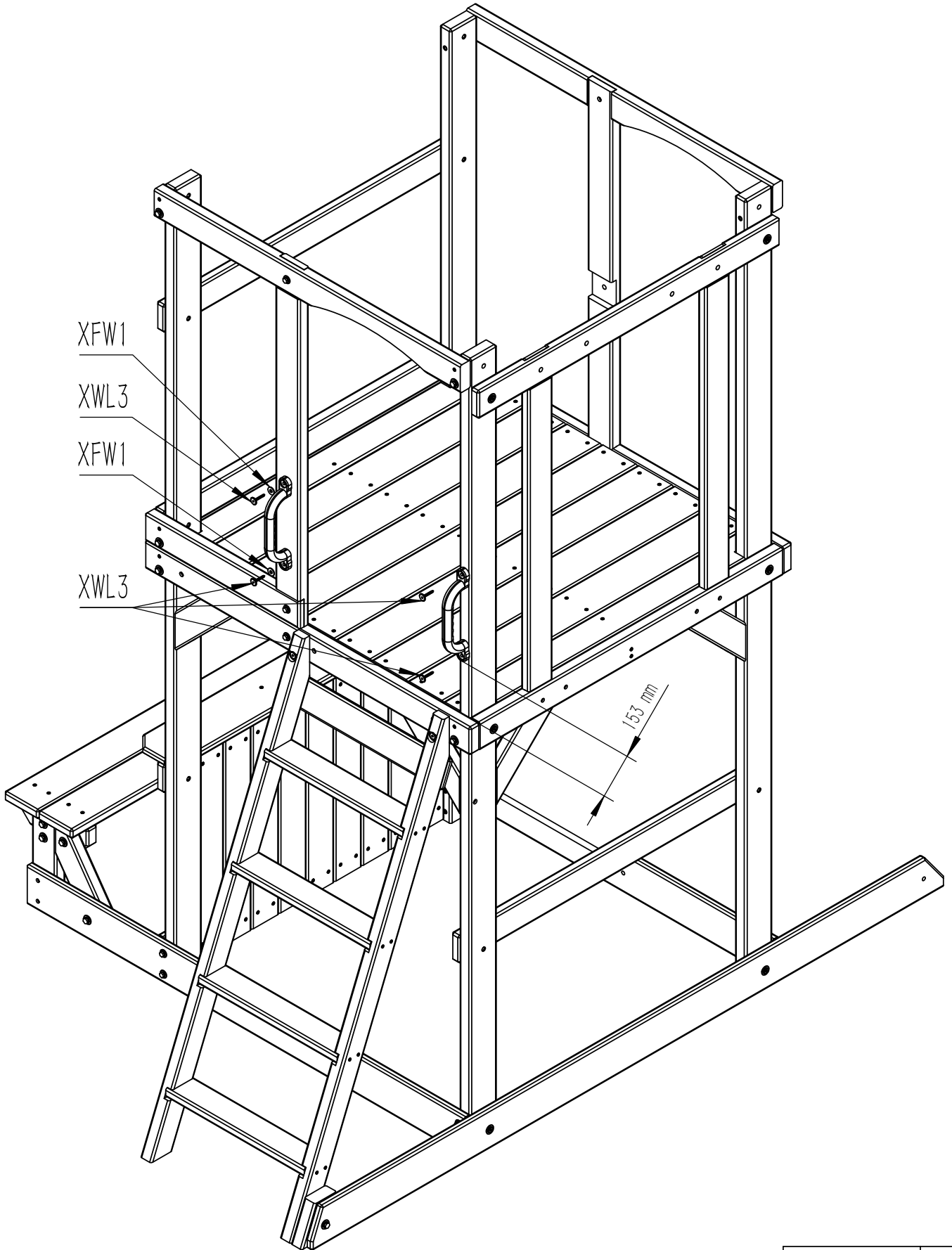

Parts	Qty
Handle	2
XWL3	4
XFW1	2

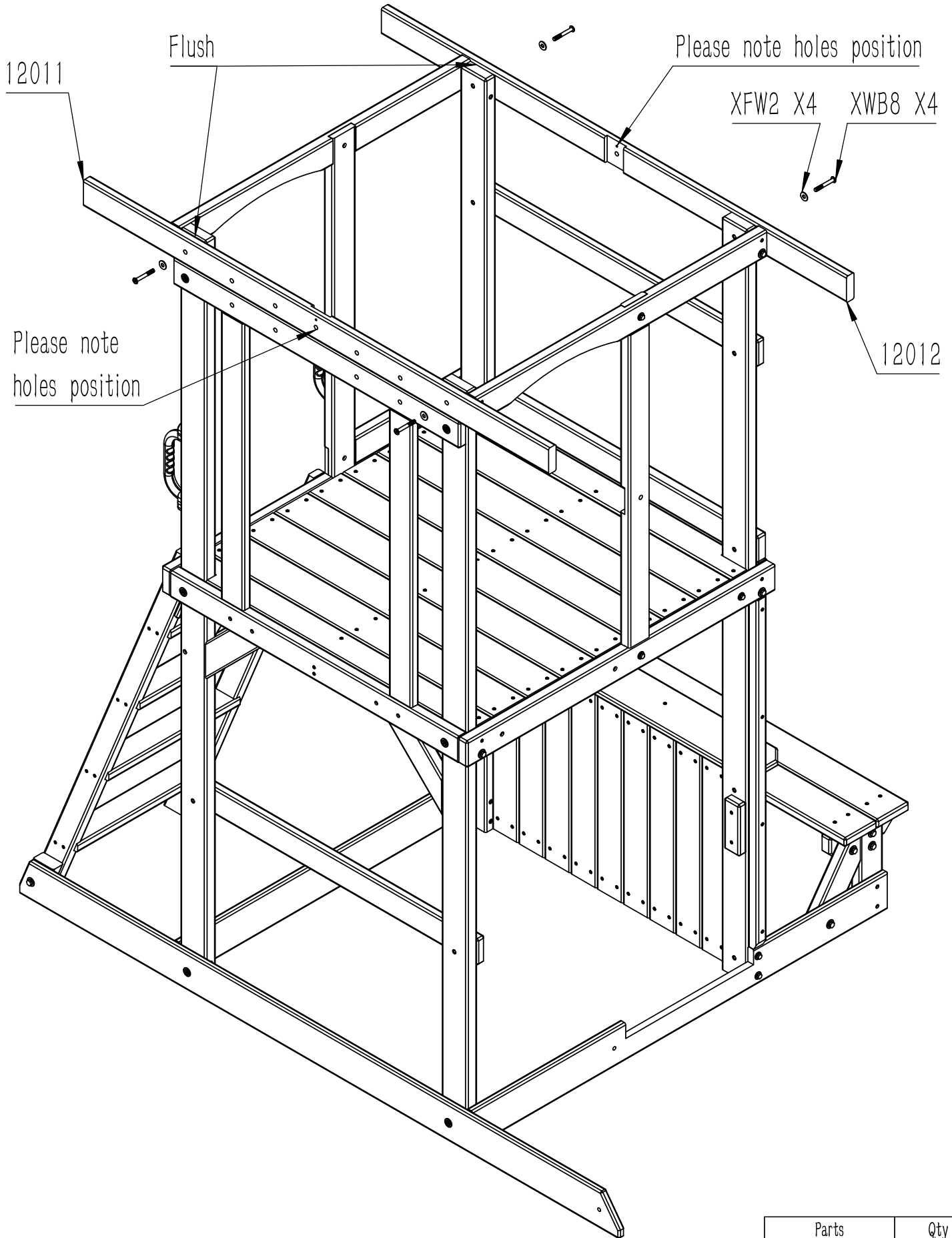

Parts	Qty
12011	1
12012	1
XWB8	4
XFW2	4

Pre-drill each hole using a 1/8" drill bit for XS1

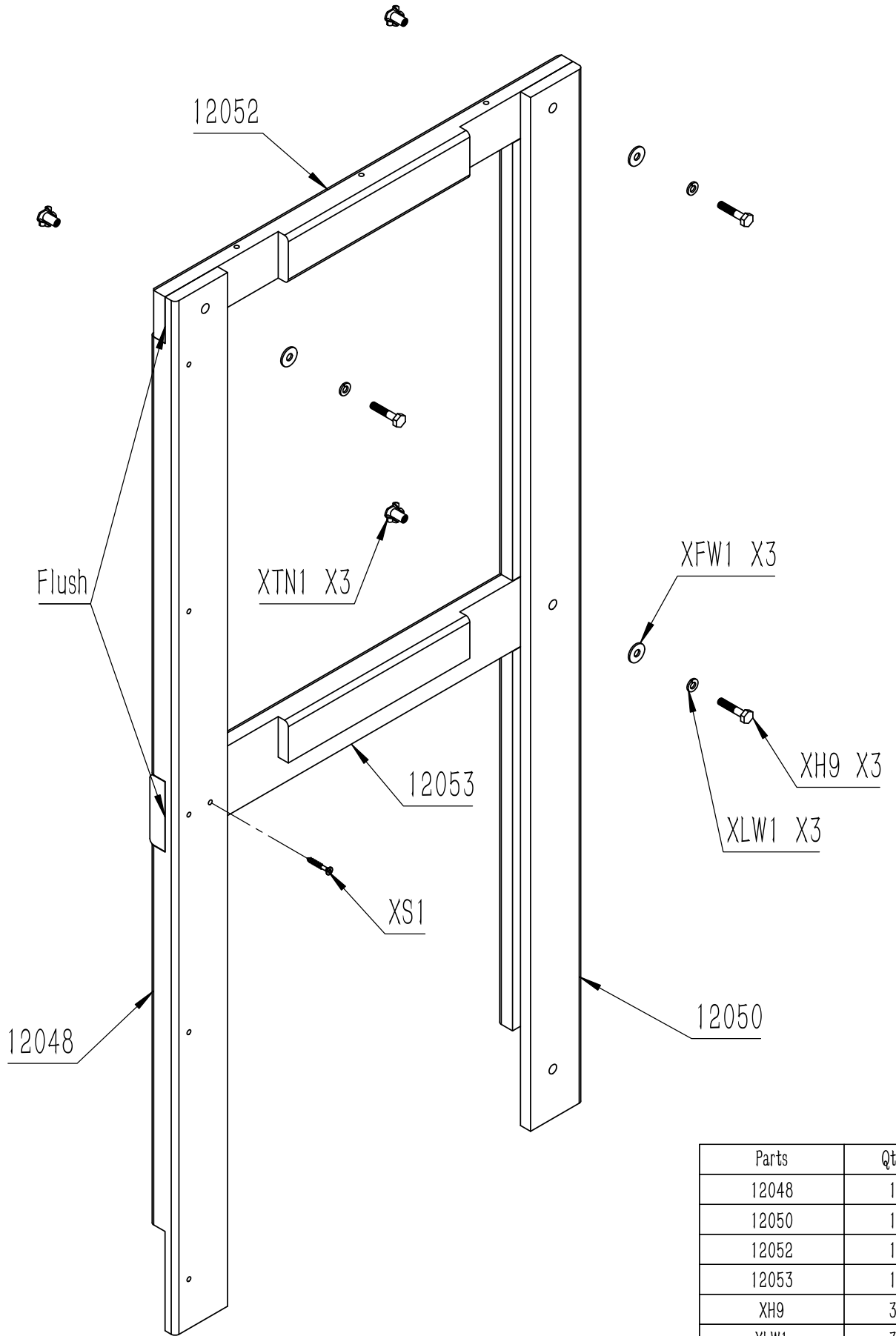

Parts	Qty
12048	1
12050	1
12052	1
12053	1
XH9	3
XLW1	3
XFW1	3
XTN1	3
XS1	1

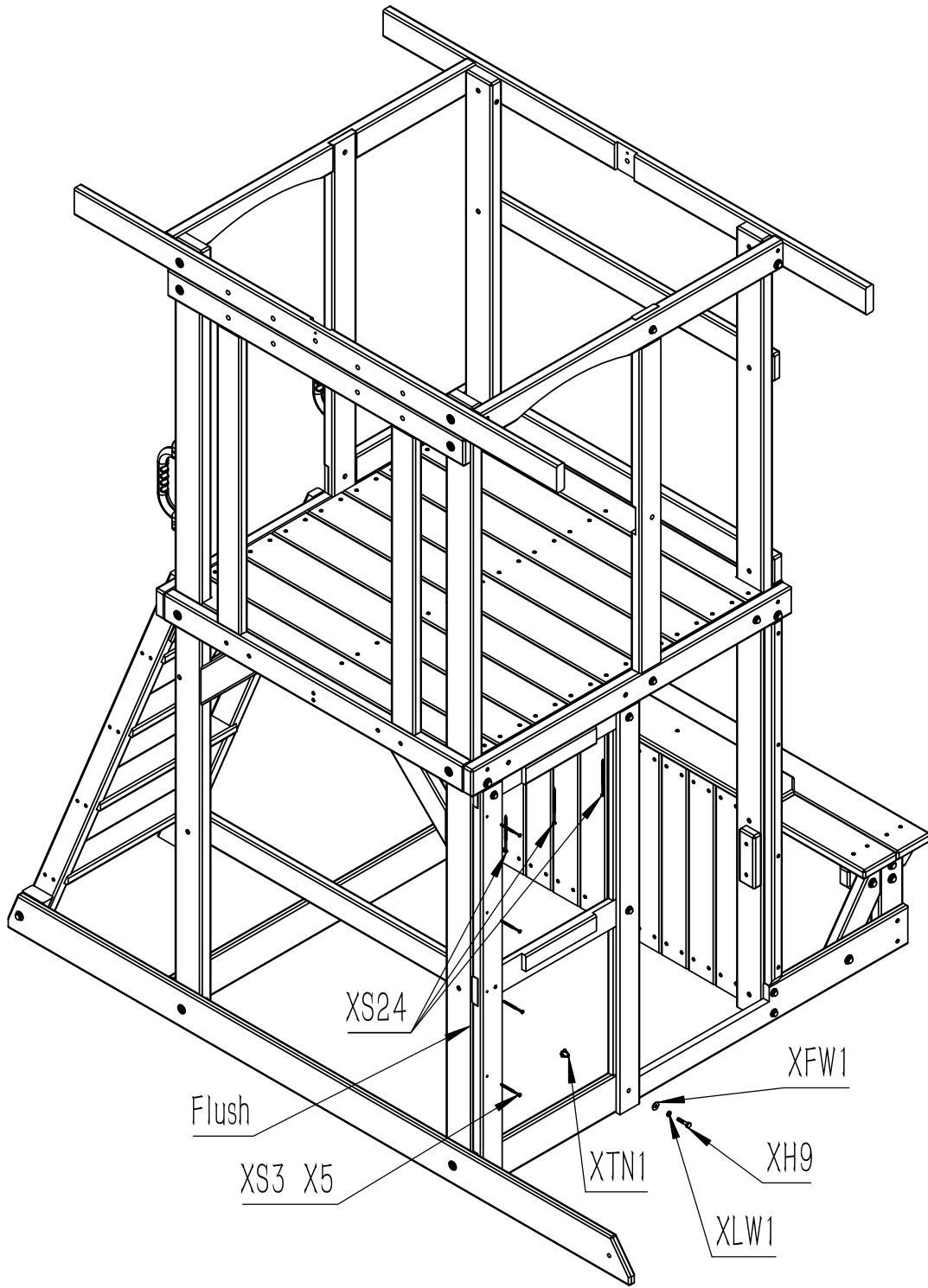

Parts	Qty
XH9	1
XLW1	1
XFW1	1
XTN1	1
XS3	5
XS24	3

Pre-drill each hole using a 1/8" drill bit for XS1

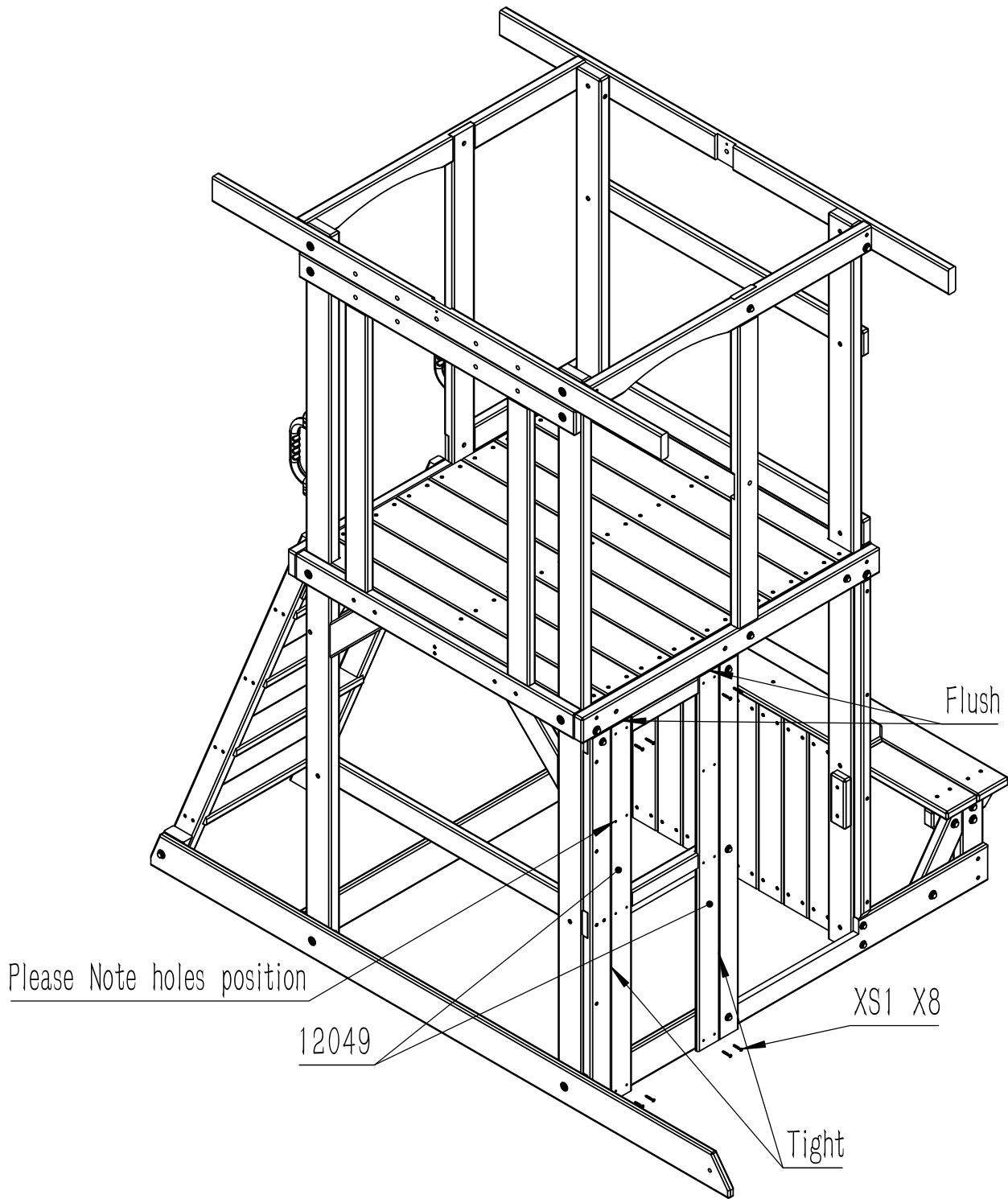

Parts	Qty
12049	2
XS1	8

Pre-drill each hole using a 1/8" drill bit for XS1

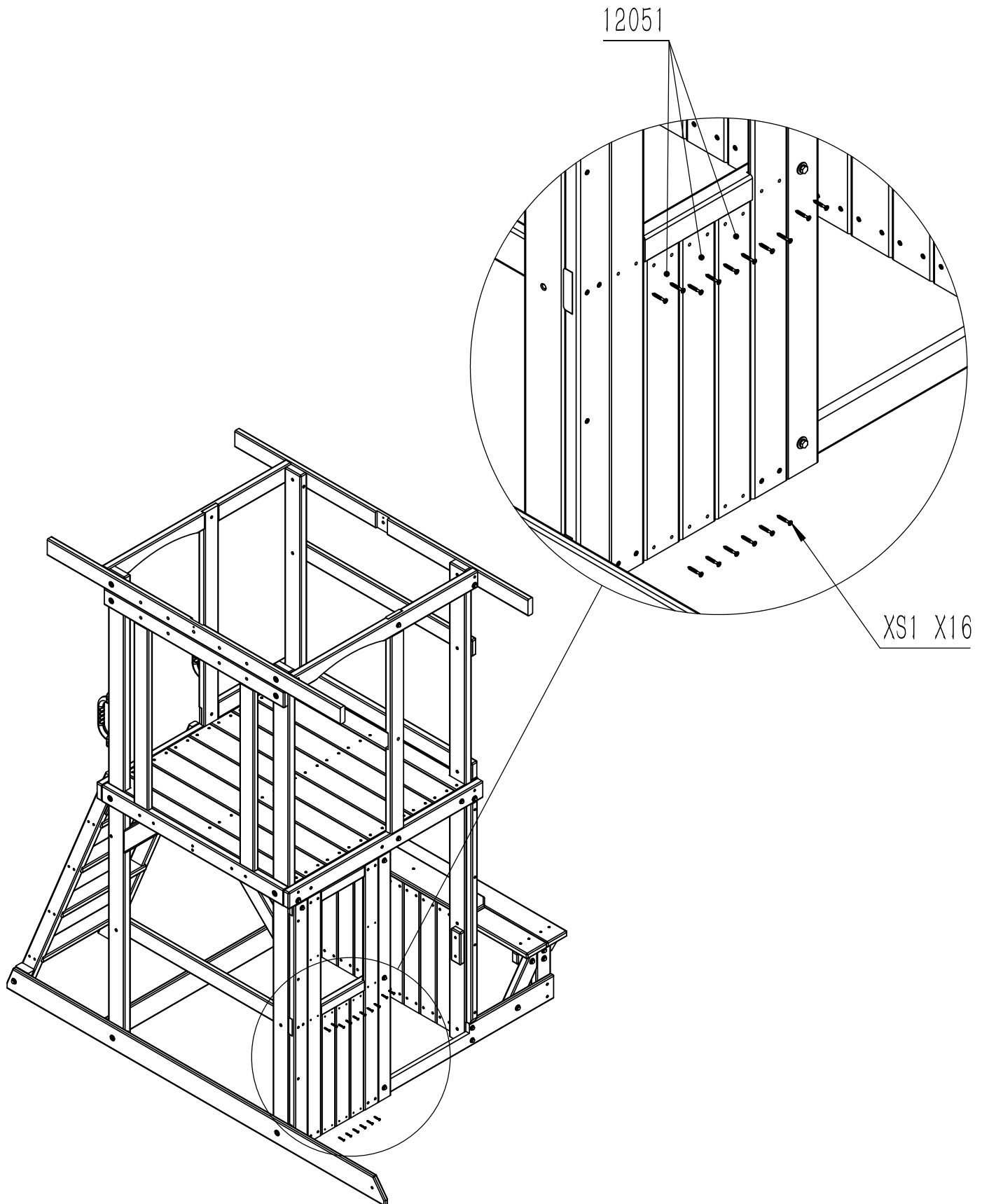

Parts	Qty
12051	3
XS1	16

Pre-drill each hole using a 1/8" drill bit for XS1

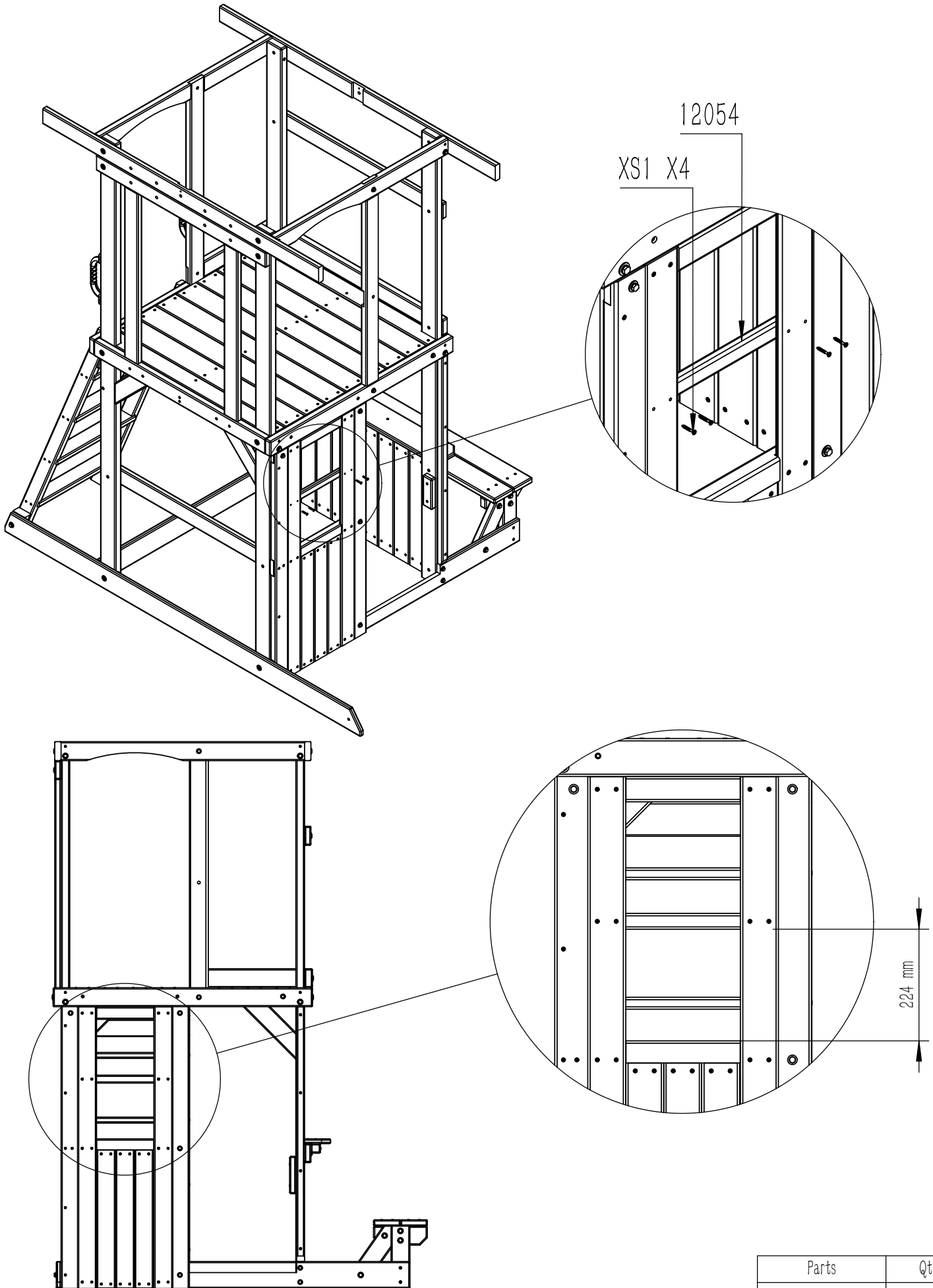

Pre-drill each hole using a 1/8" drill bit for XWL5

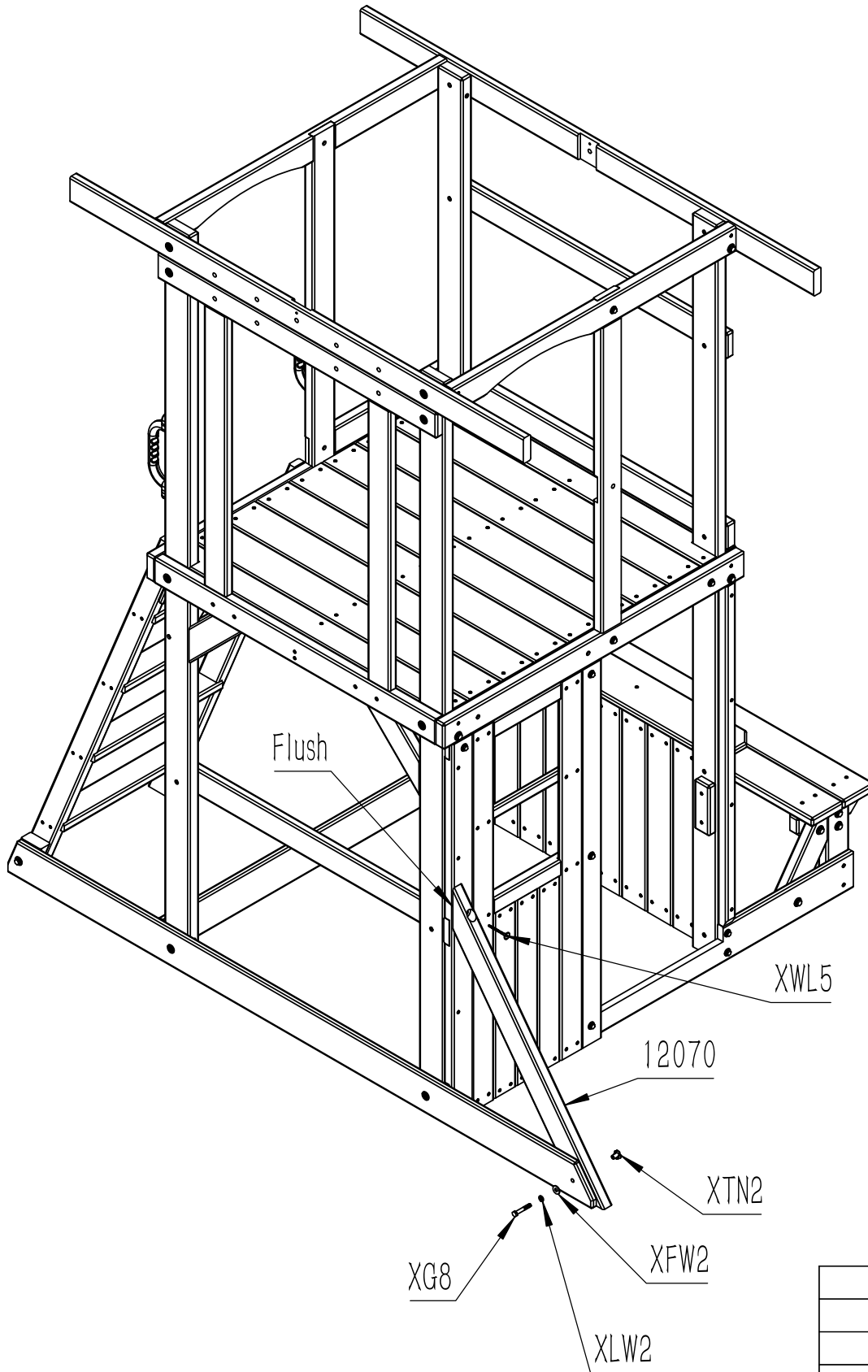

Parts	Qty
12070	1
XWL5	1
XG8	1
XLW2	1
XFW2	1
XTN2	1

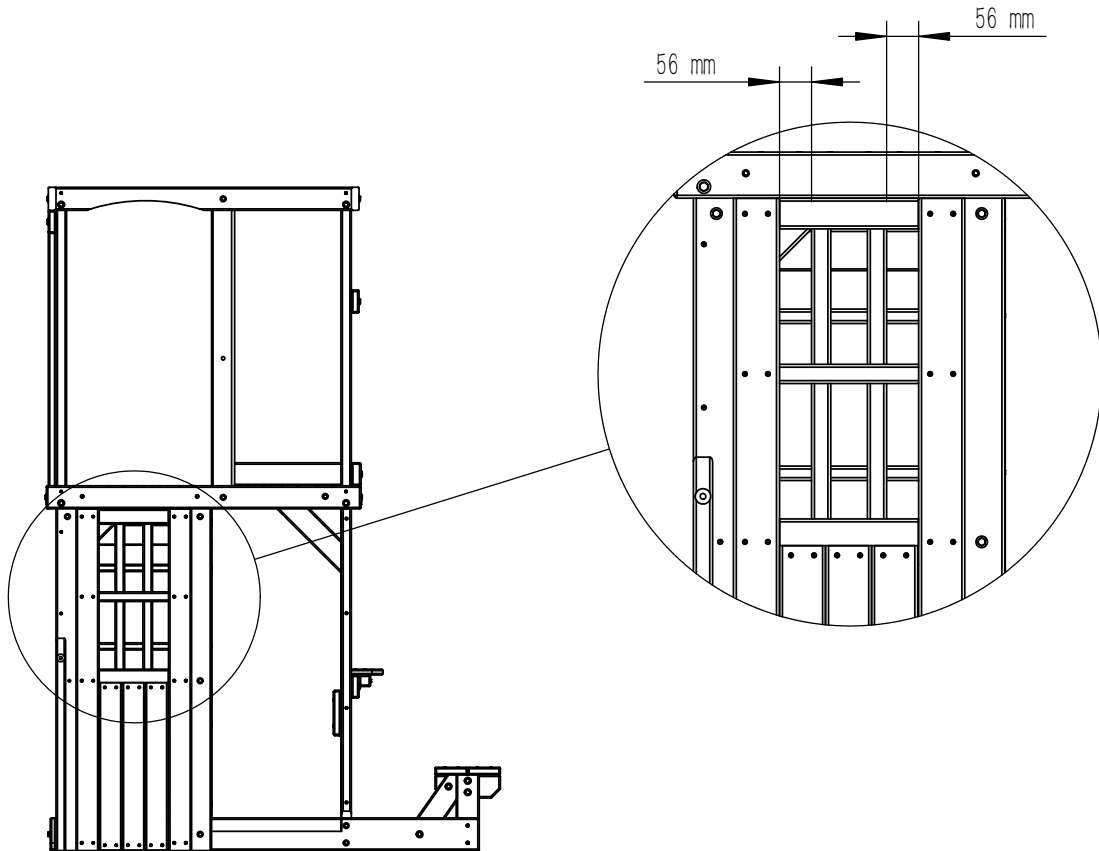
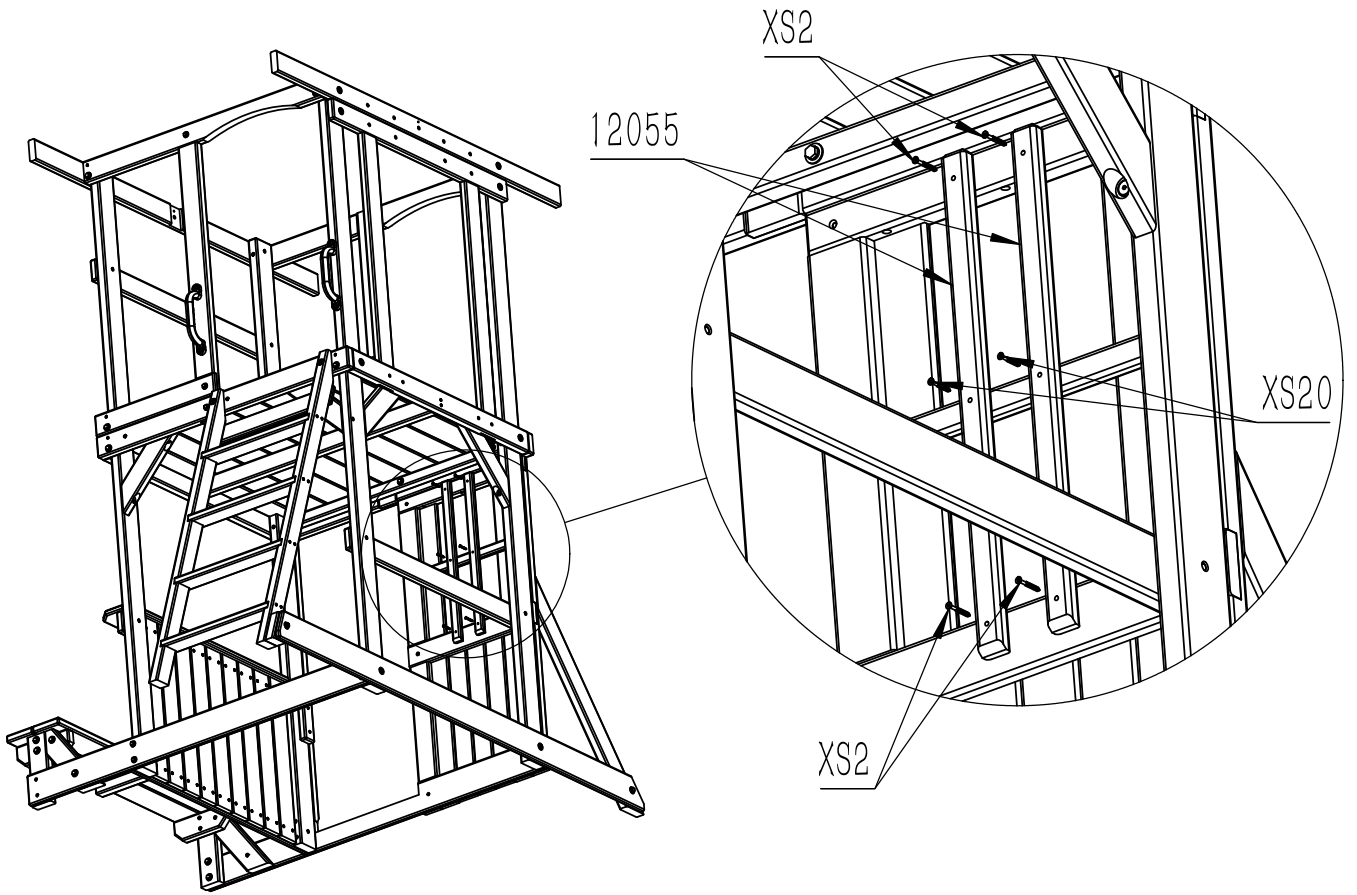

Parts	Qty
12055	2
XS2	4
XS20	2

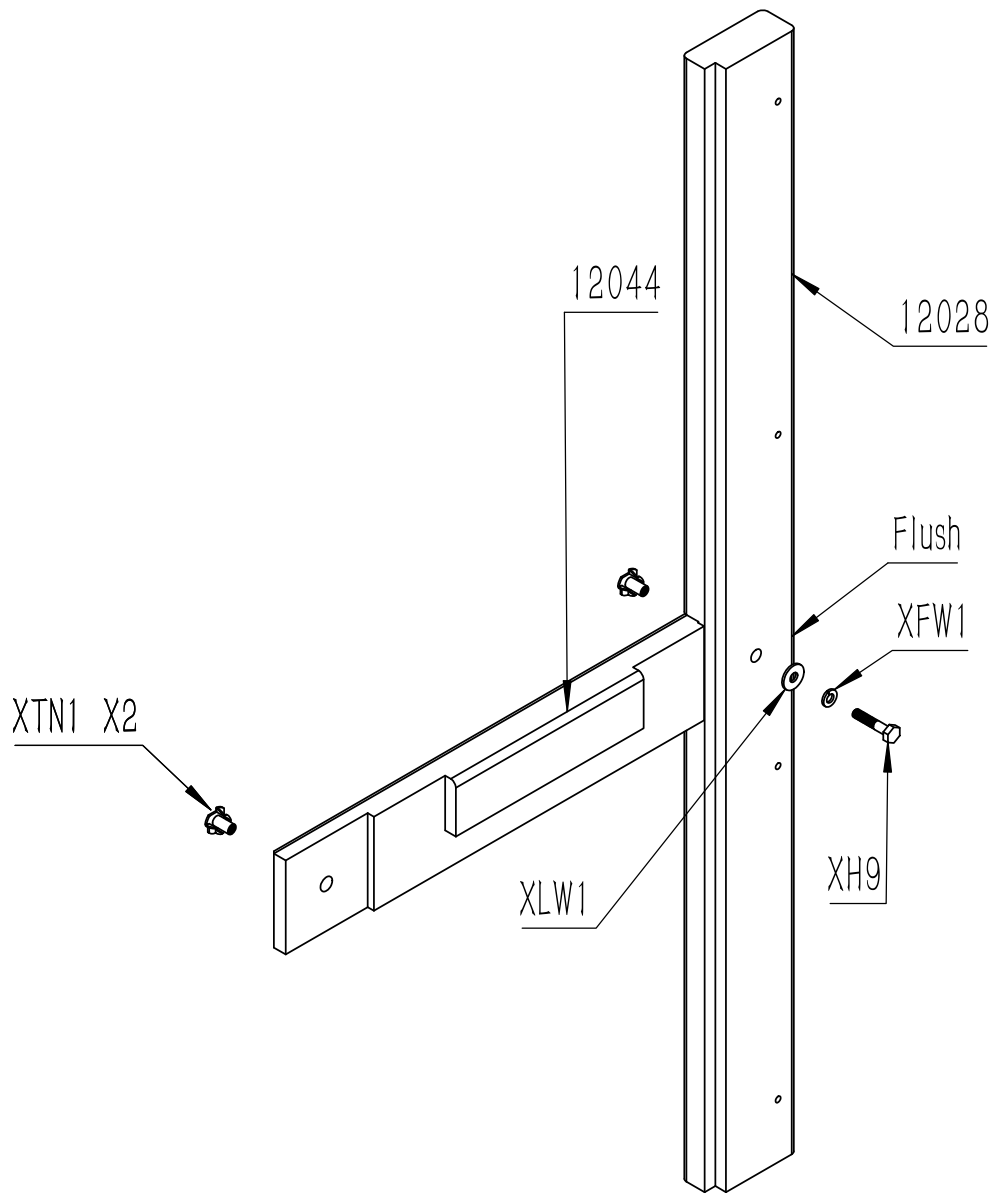

Parts	Qty
12028	1
12044	1
XH9	1
XFW1	1
XLW1	1
XTN1	2

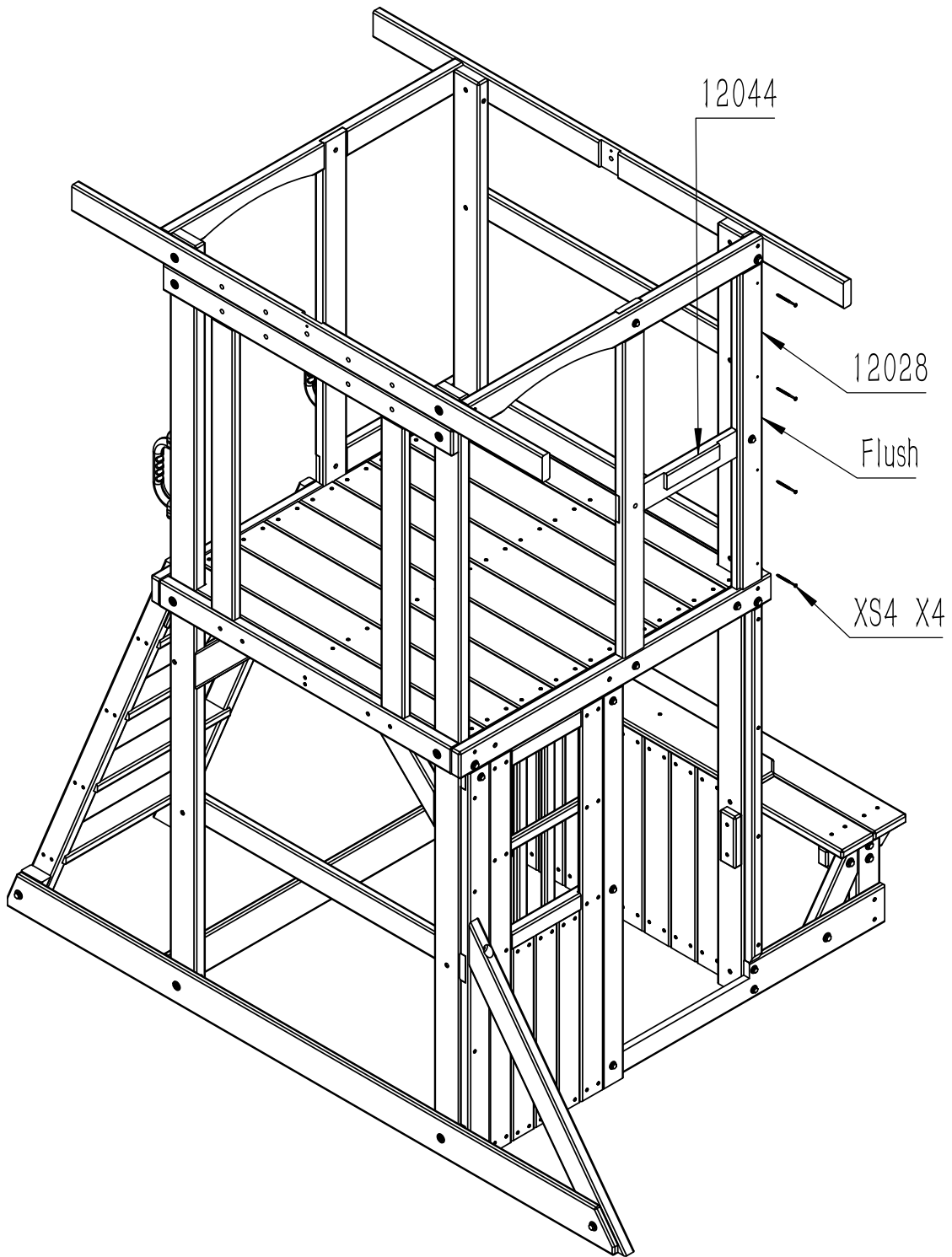

Parts	Qty
XS4	4

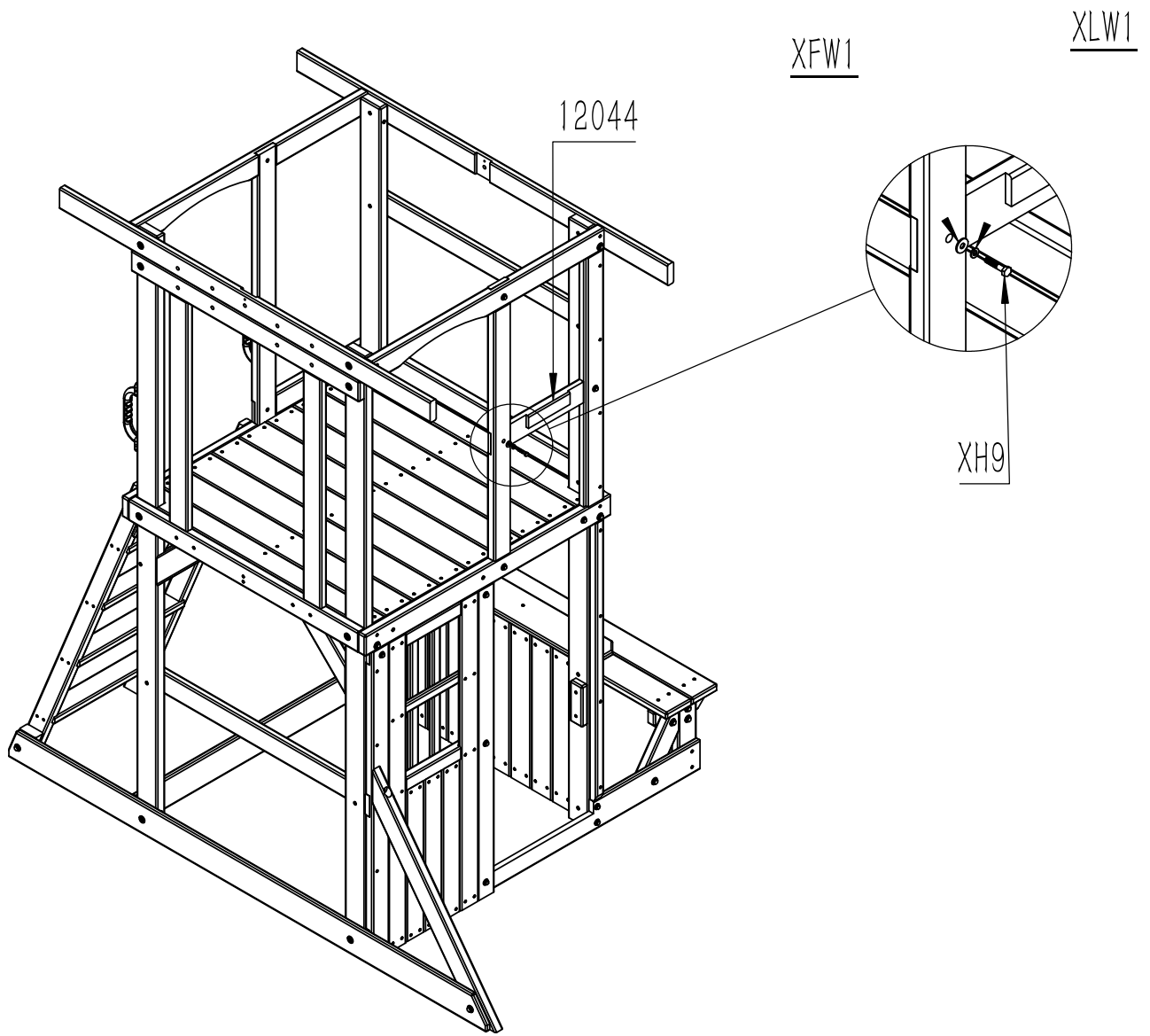

Parts	Qty
XH9	1
XLW1	1
XFW1	1

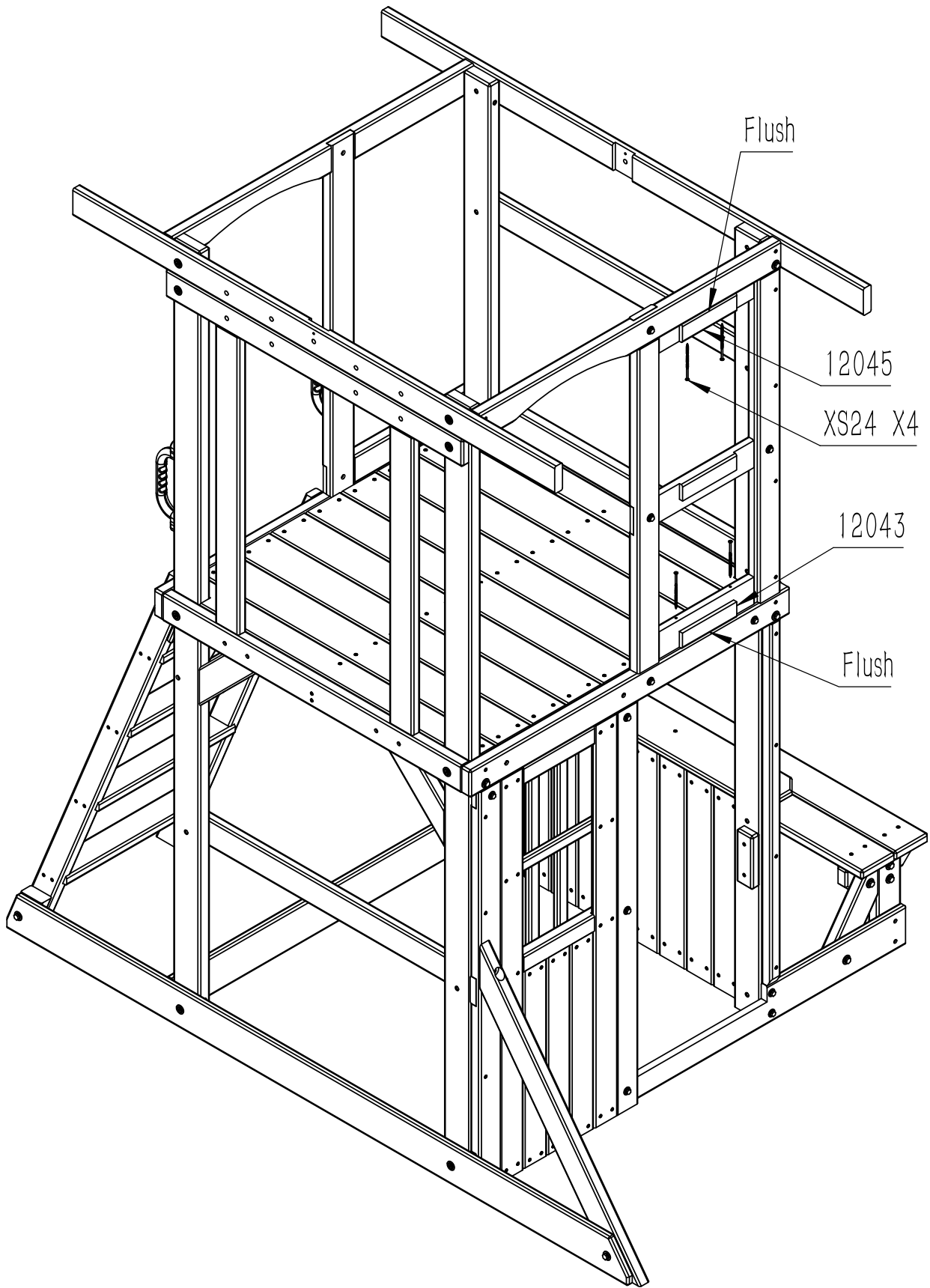

Parts	Qty
12043	1
12045	1
XS24	4

Pre-drill 4 holes using a 1/8" drill bit for XS10

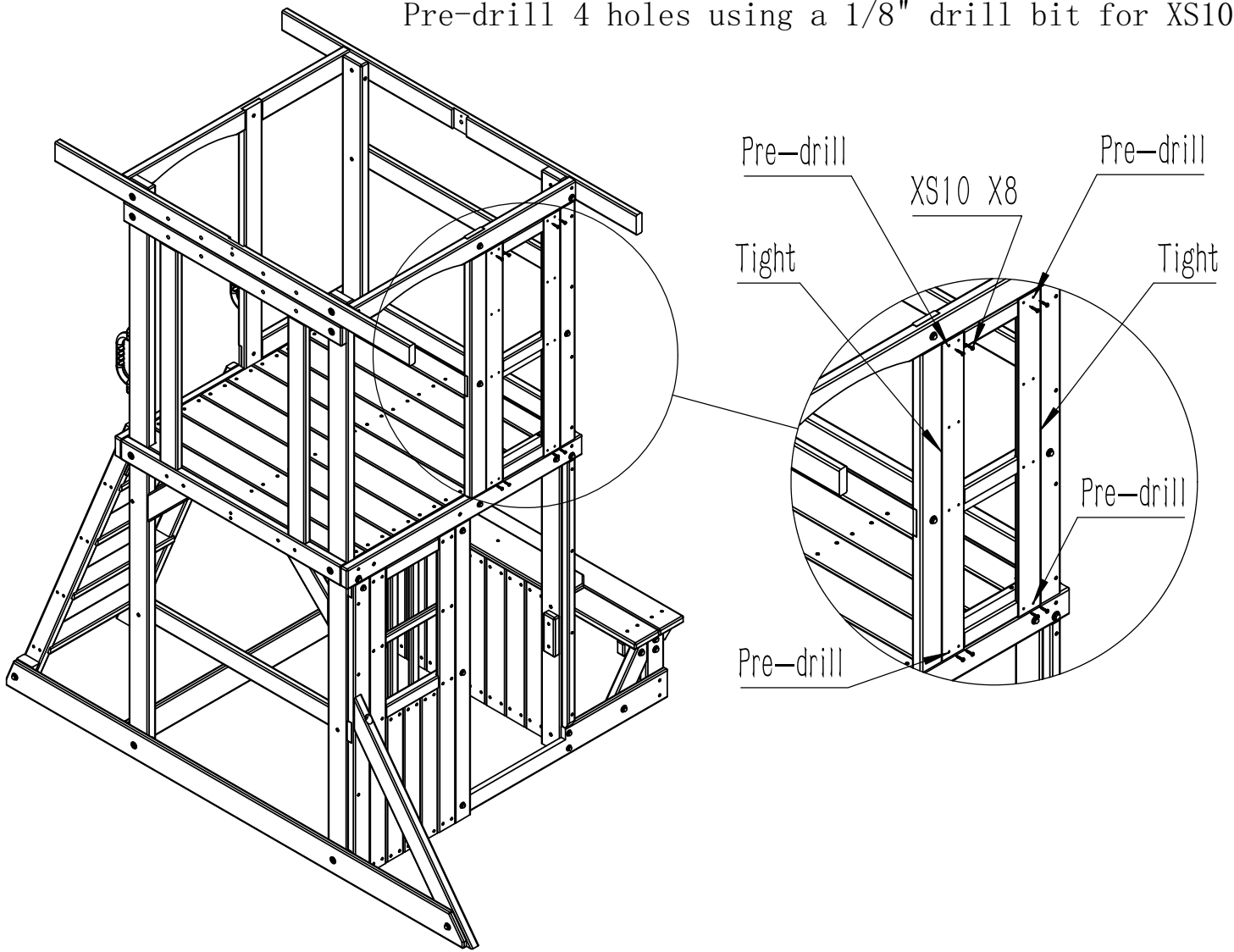

Please note hole position

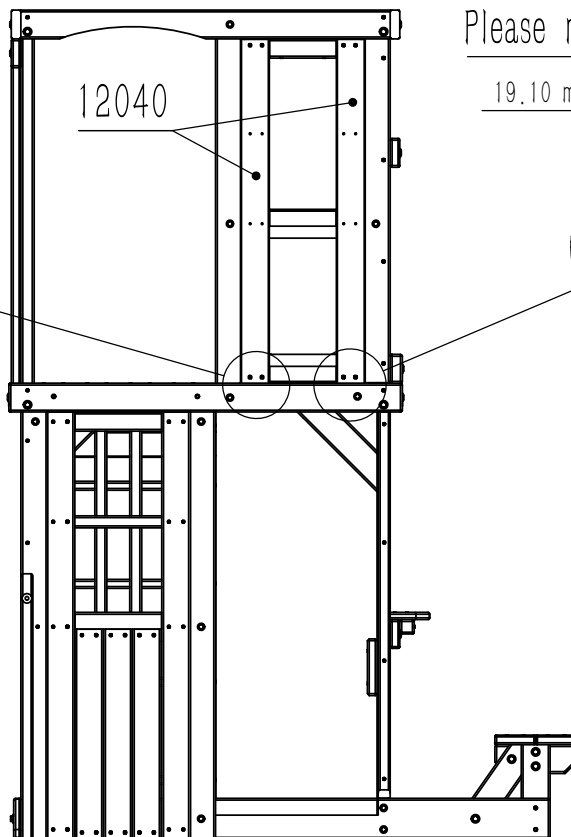
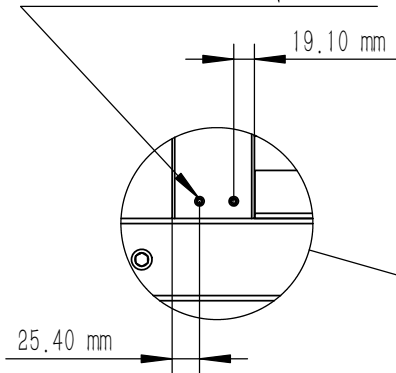

Please note hole position

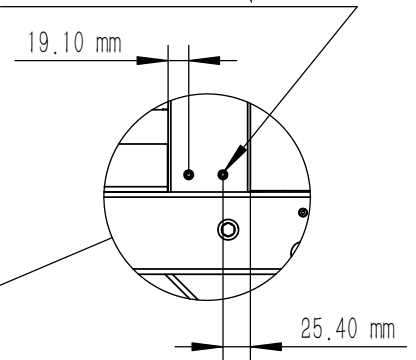

Parts	Qty
12040	2
XS10	8

Pre-drill 2 holes using a 1/8" drill bit for XS10

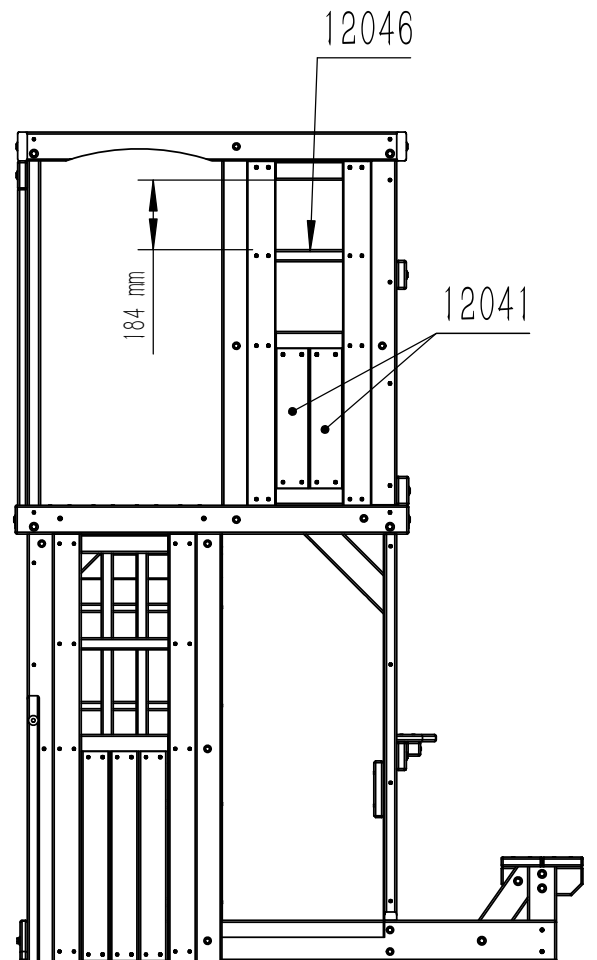
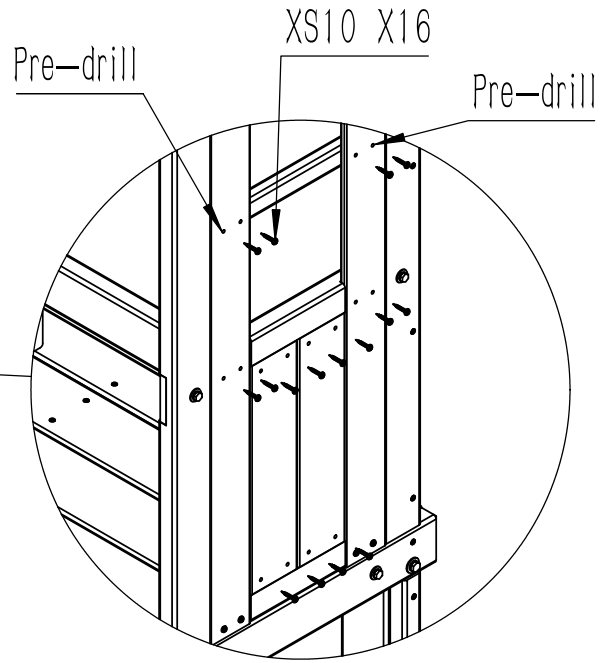
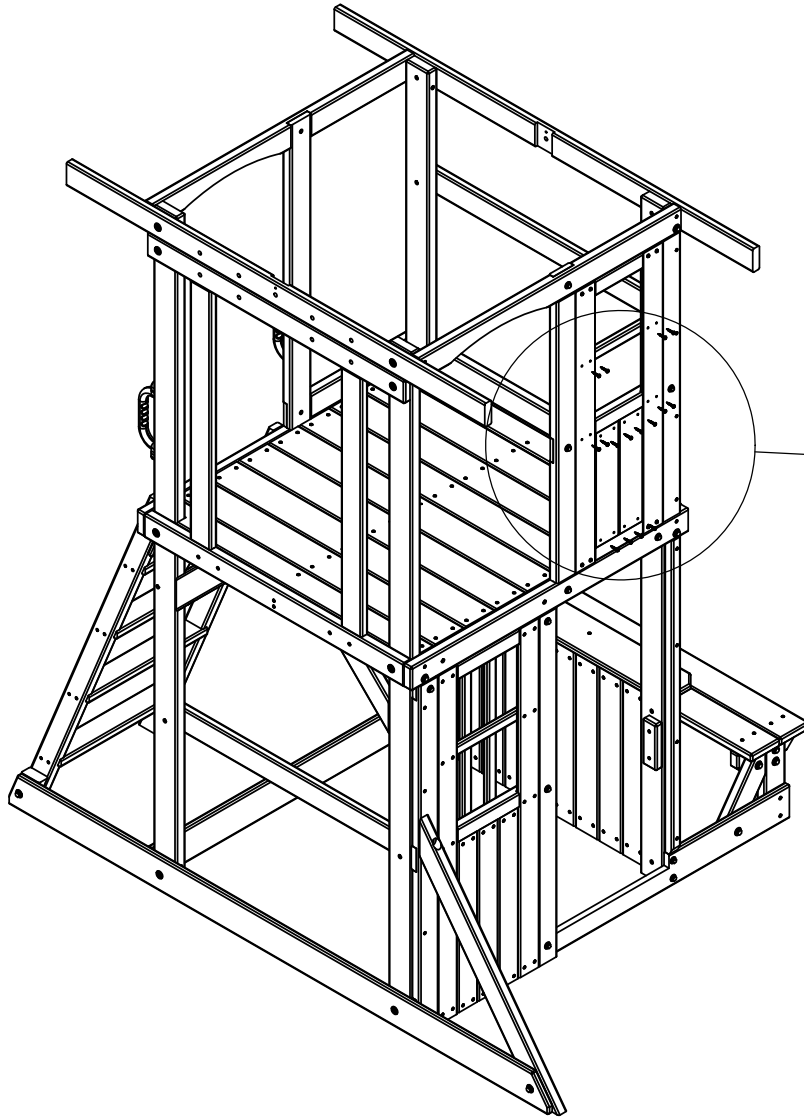

Parts	Qty
12041	2
12046	1
XS10	16

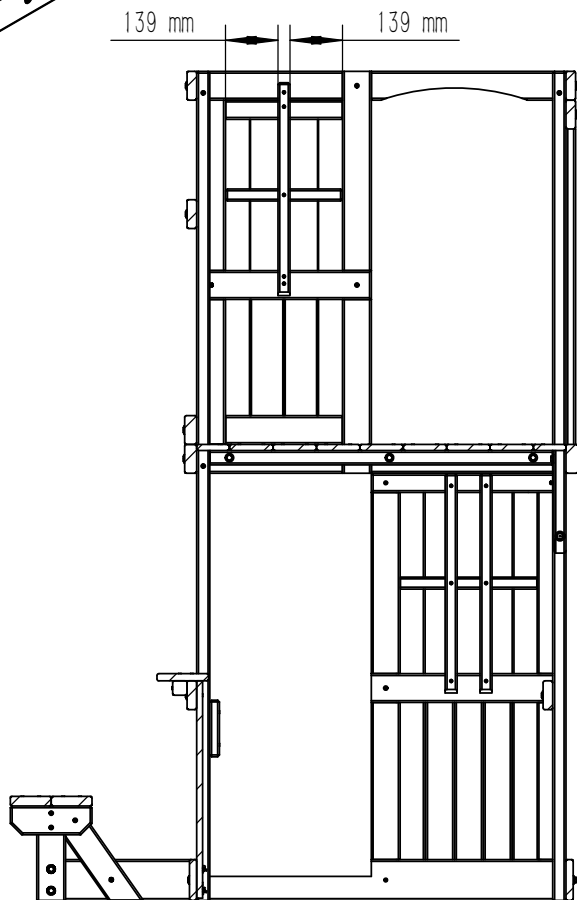
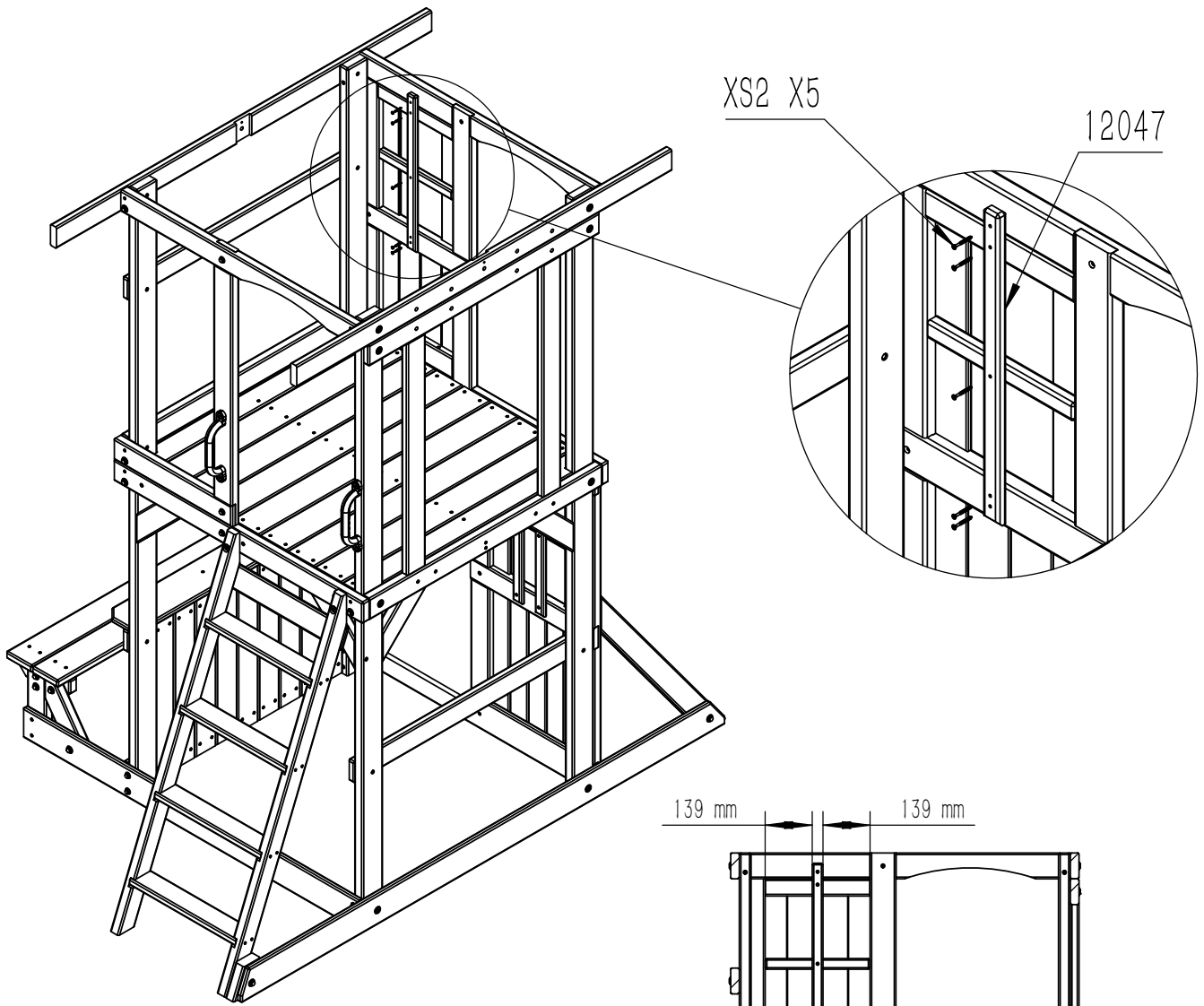

Parts	Qty
12047	1
XS2	5

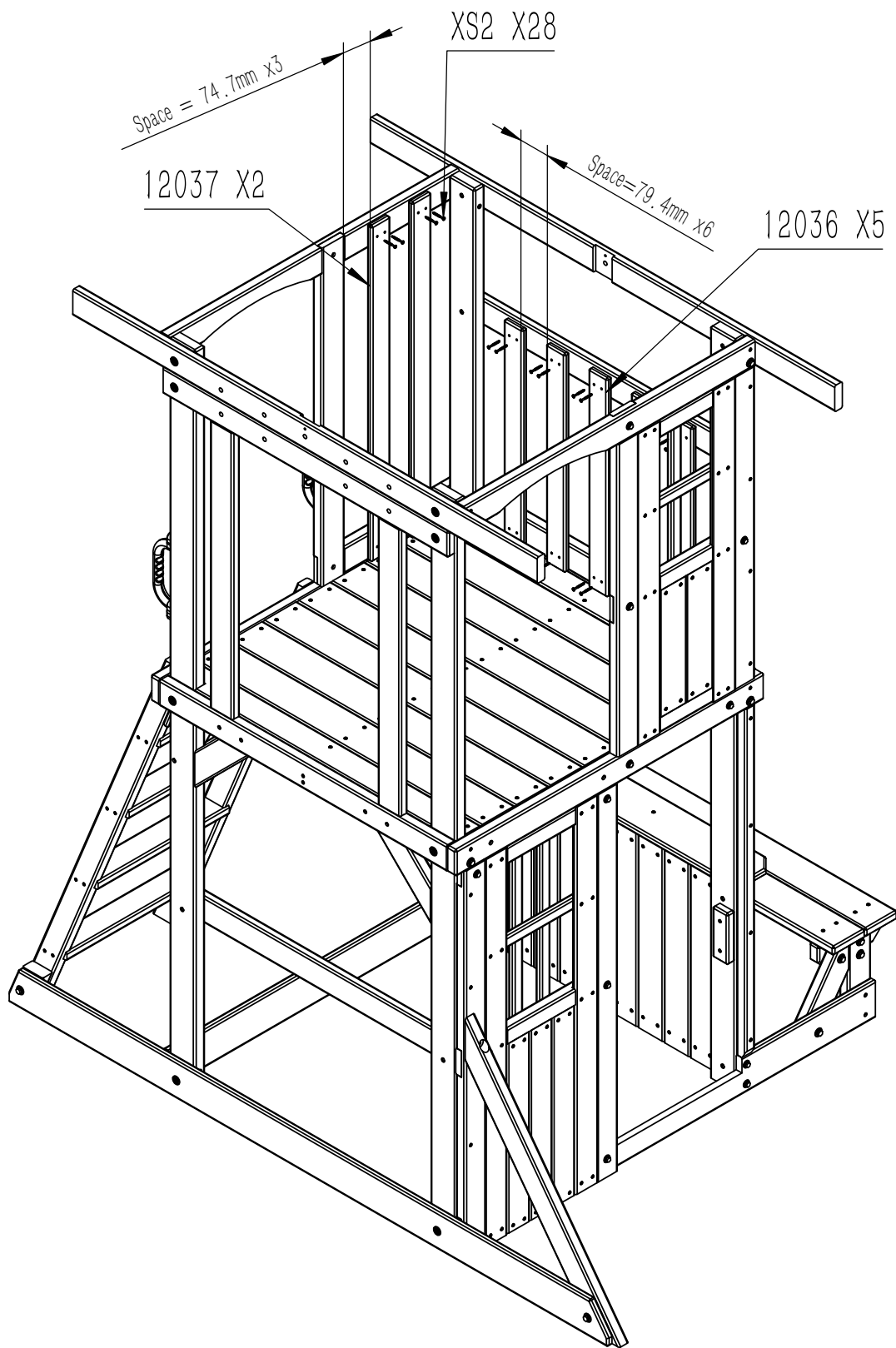

Parts	Qty
12036	5
12037	2
XS2	28

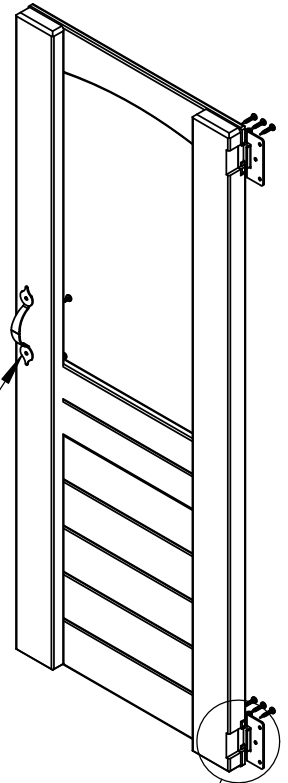
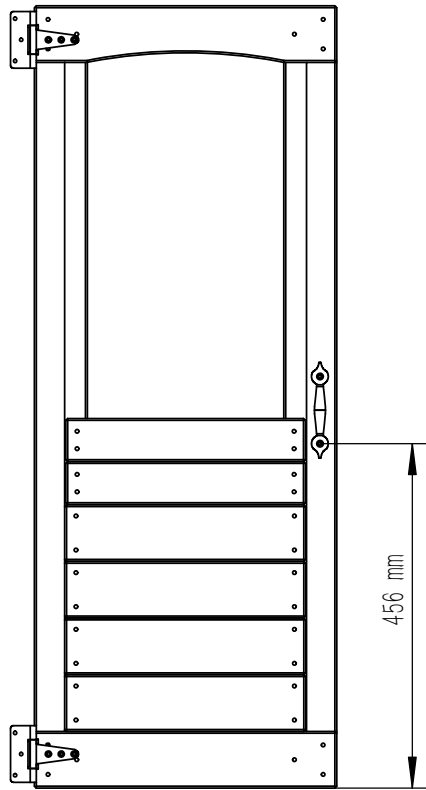

XS0

Steel Handle

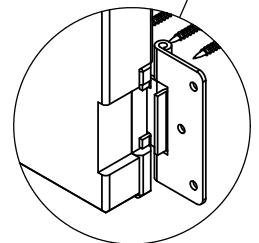

Hinge

XS0

XS0

Steel Handle

Hinge

XS0

Door

Parts	Qty
Door	1
Hinge	2
Steel Handle	2
XS0	10

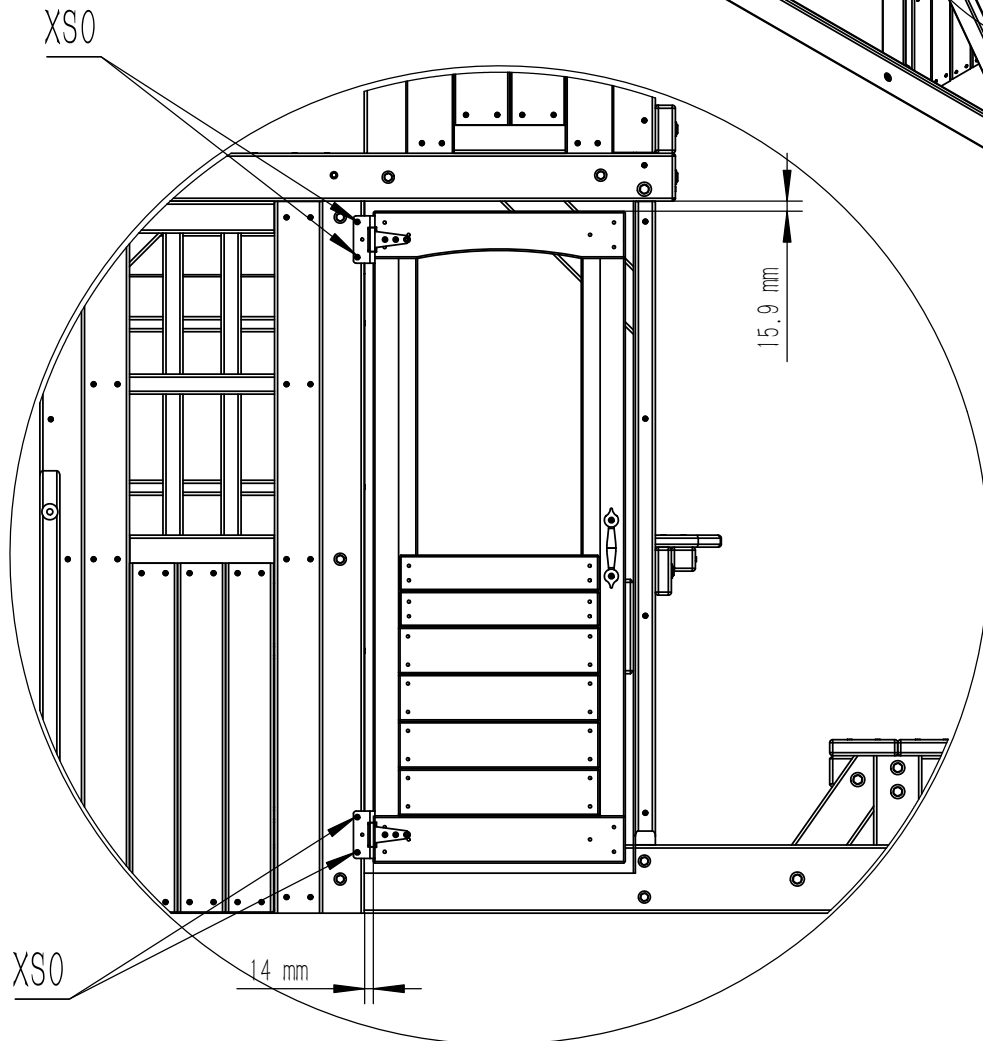
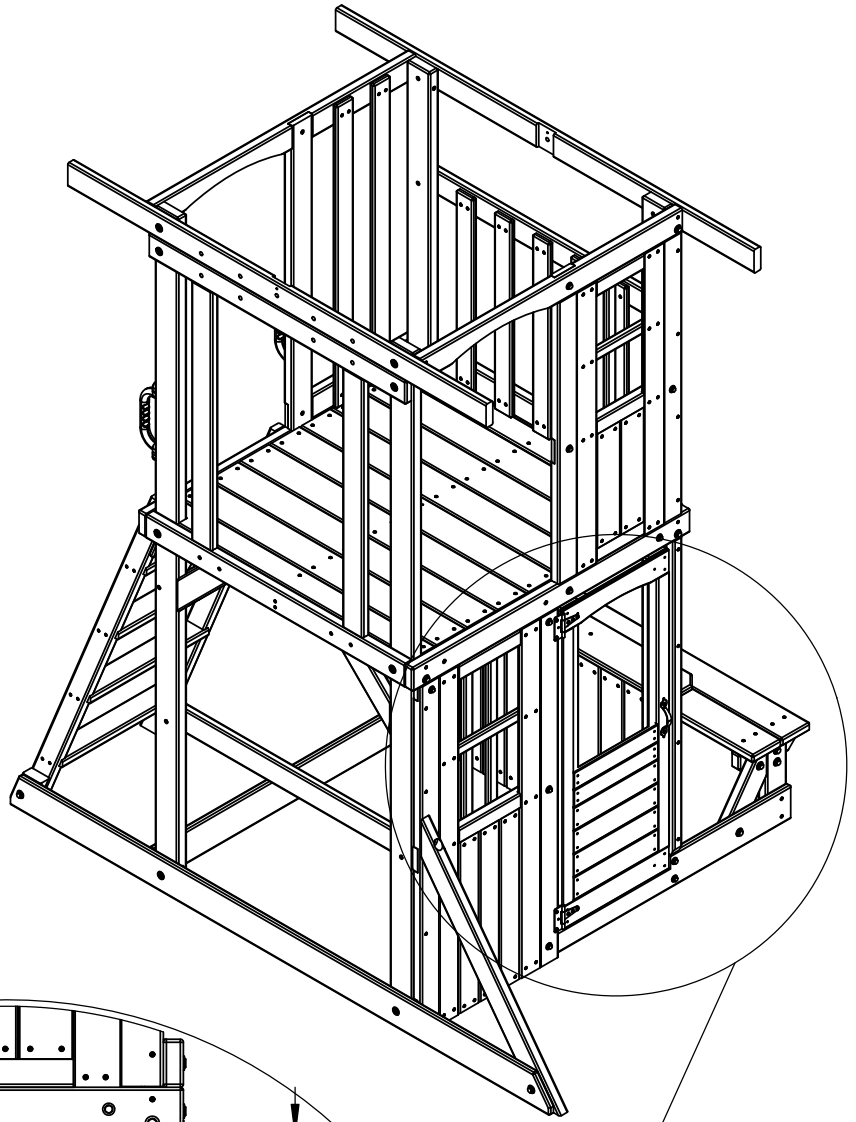

Parts	Qty
XS0	4

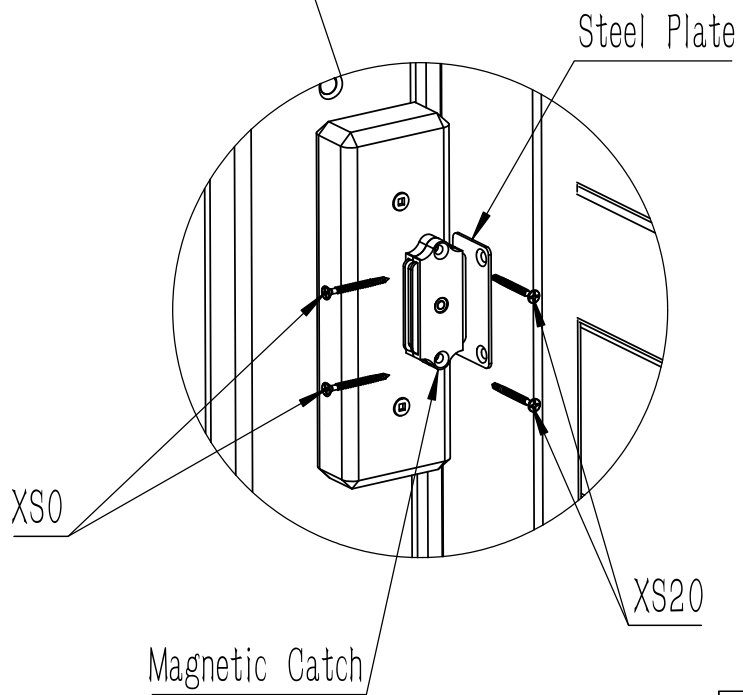
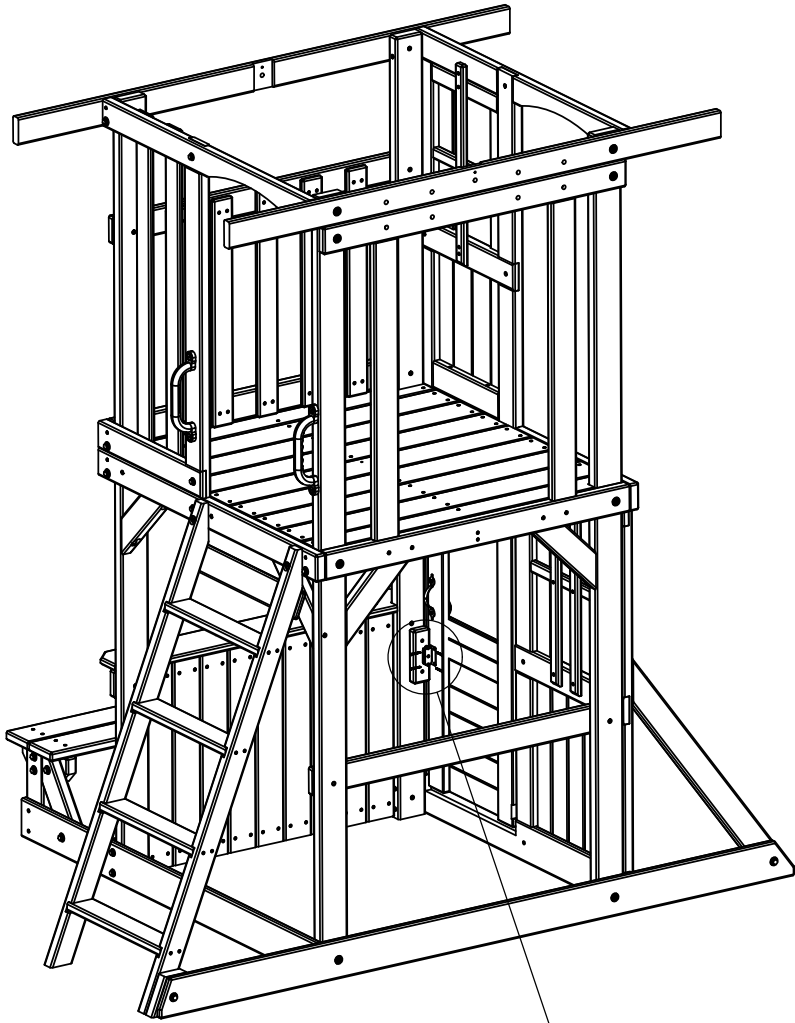

Parts	Qty
Magnetic Catch	1
Steel Plate	1
XS20	2
XS0	2

Please note angle

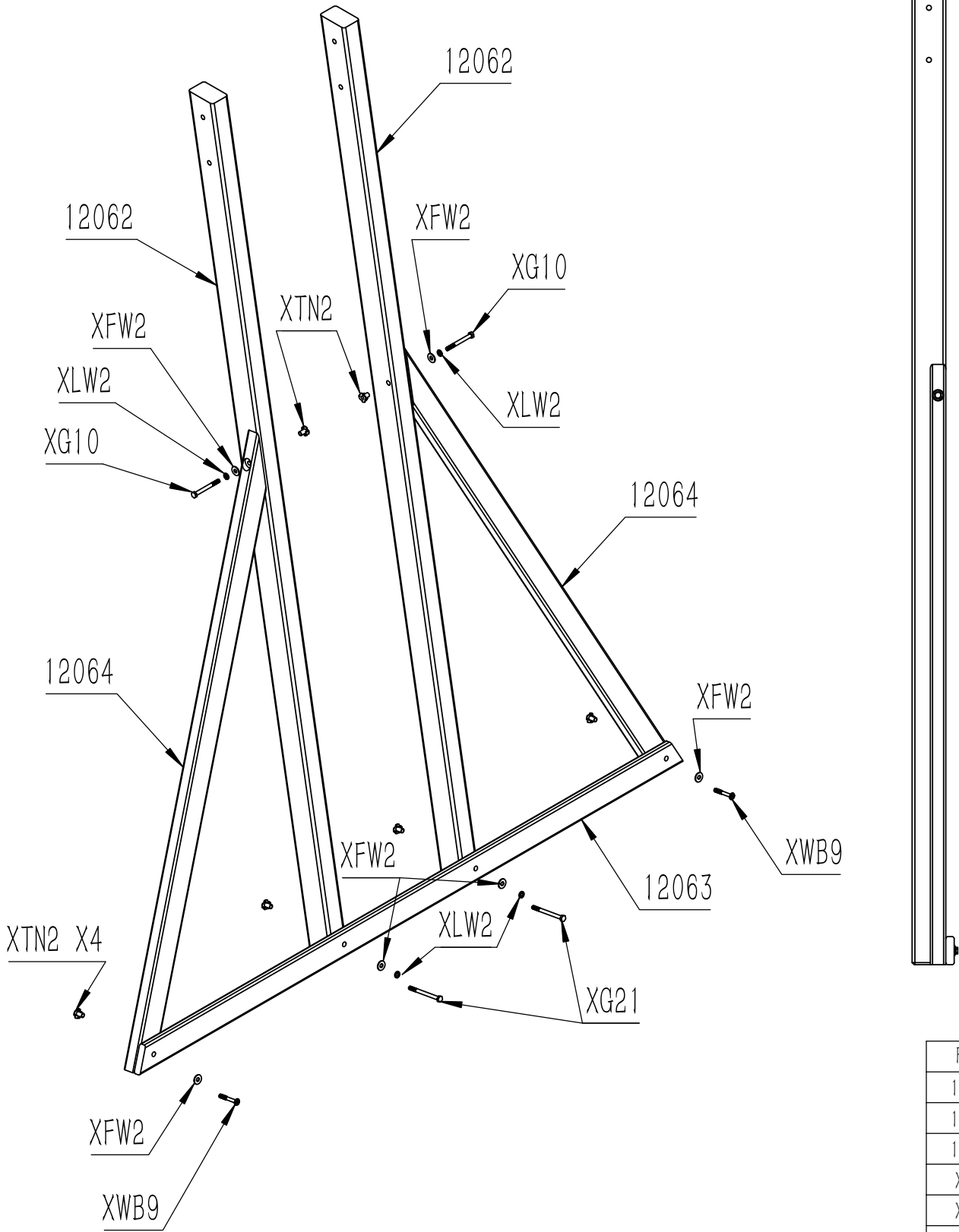

Parts	Qty
12062	2
12064	2
12063	1
XG10	2
XG21	2
XWB9	2
XLW2	4
XFW2	6
XTN2	6

Pre-drill each hole using a 1/8" drill bit for XWL3

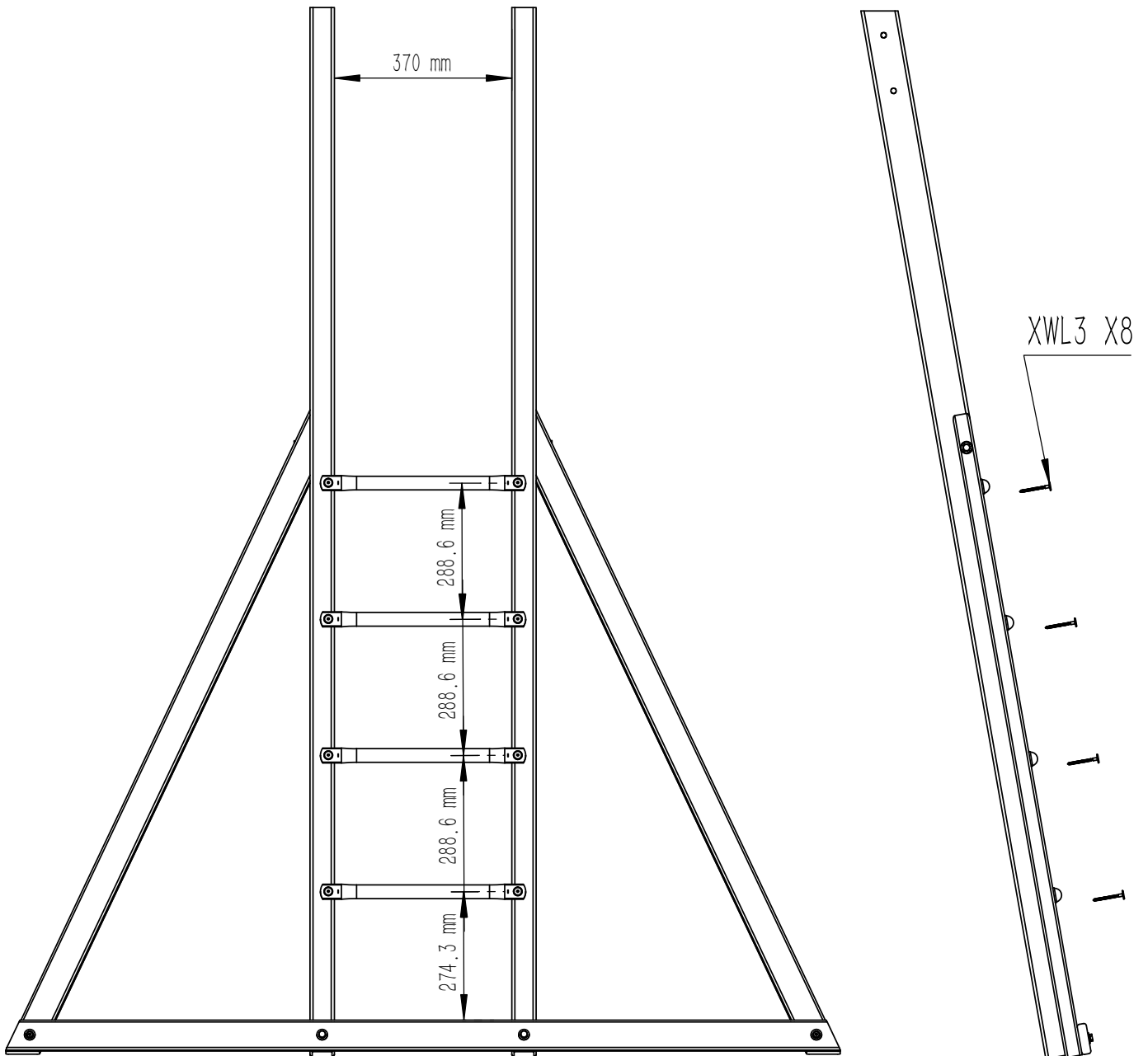

Parts	Qty
Monkey Bar	4
XWL3	8

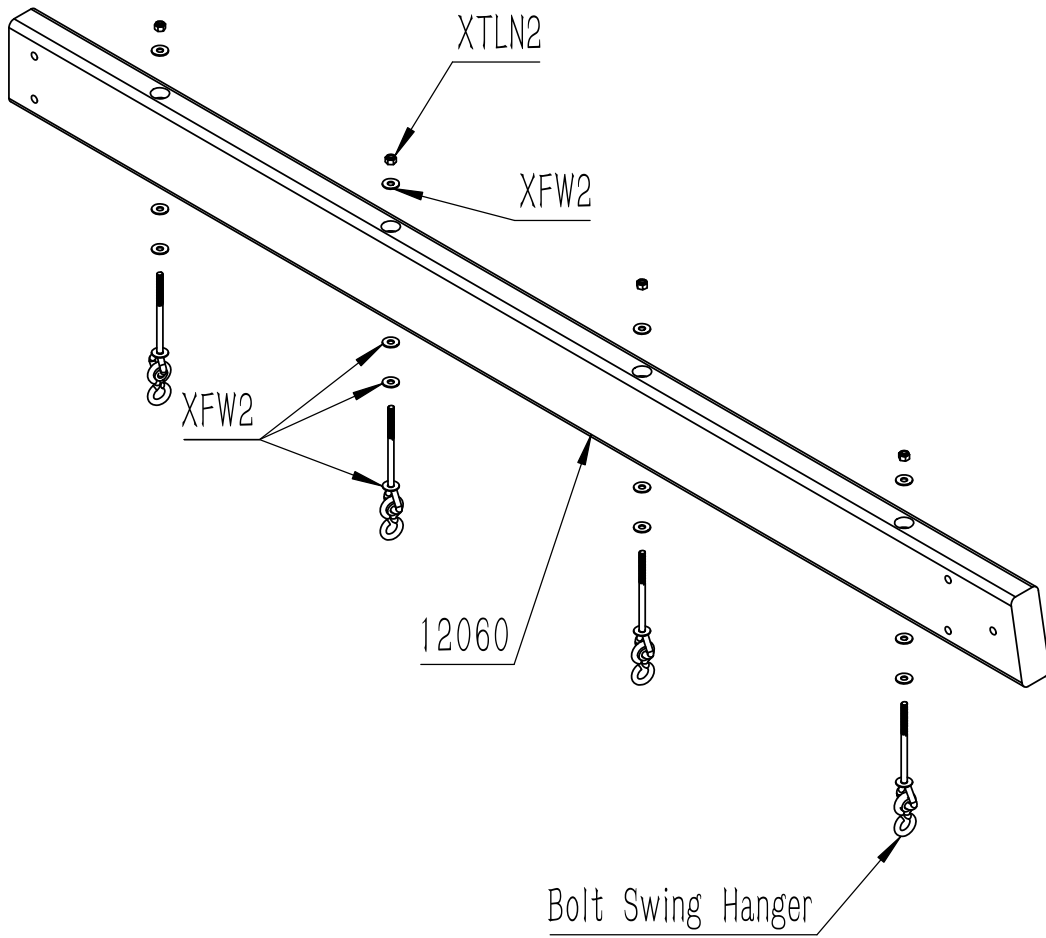
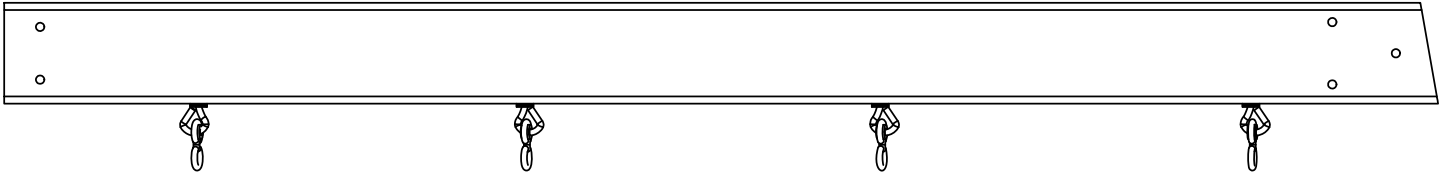

Parts	Qty
12060	1
Bolt Swing Hanger	4
XFW2	8

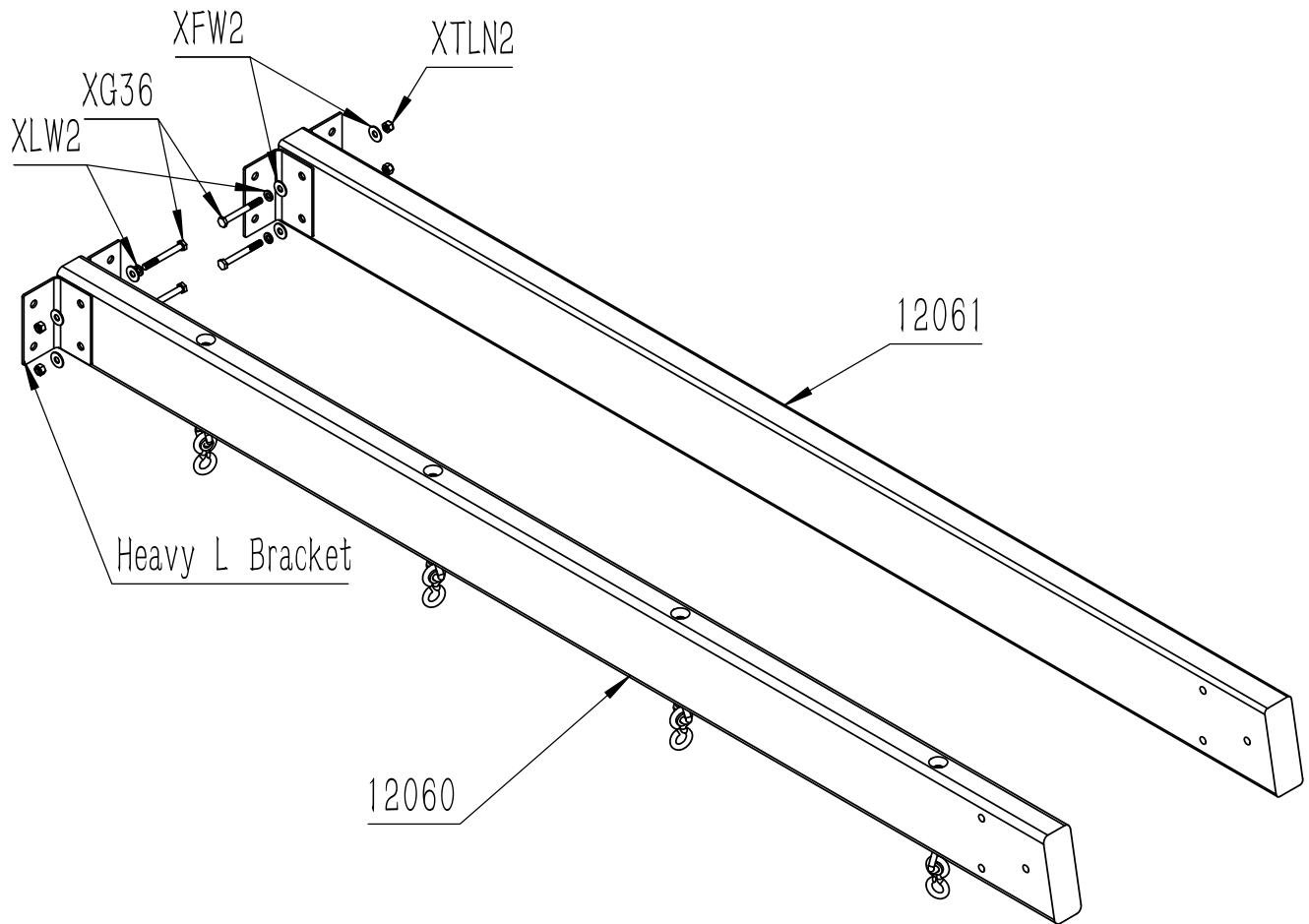

Parts	Qty
12061	1
Heavy L Bracekt	4
XG36	4
XFW2	8
XLW2	4
XLN2	4

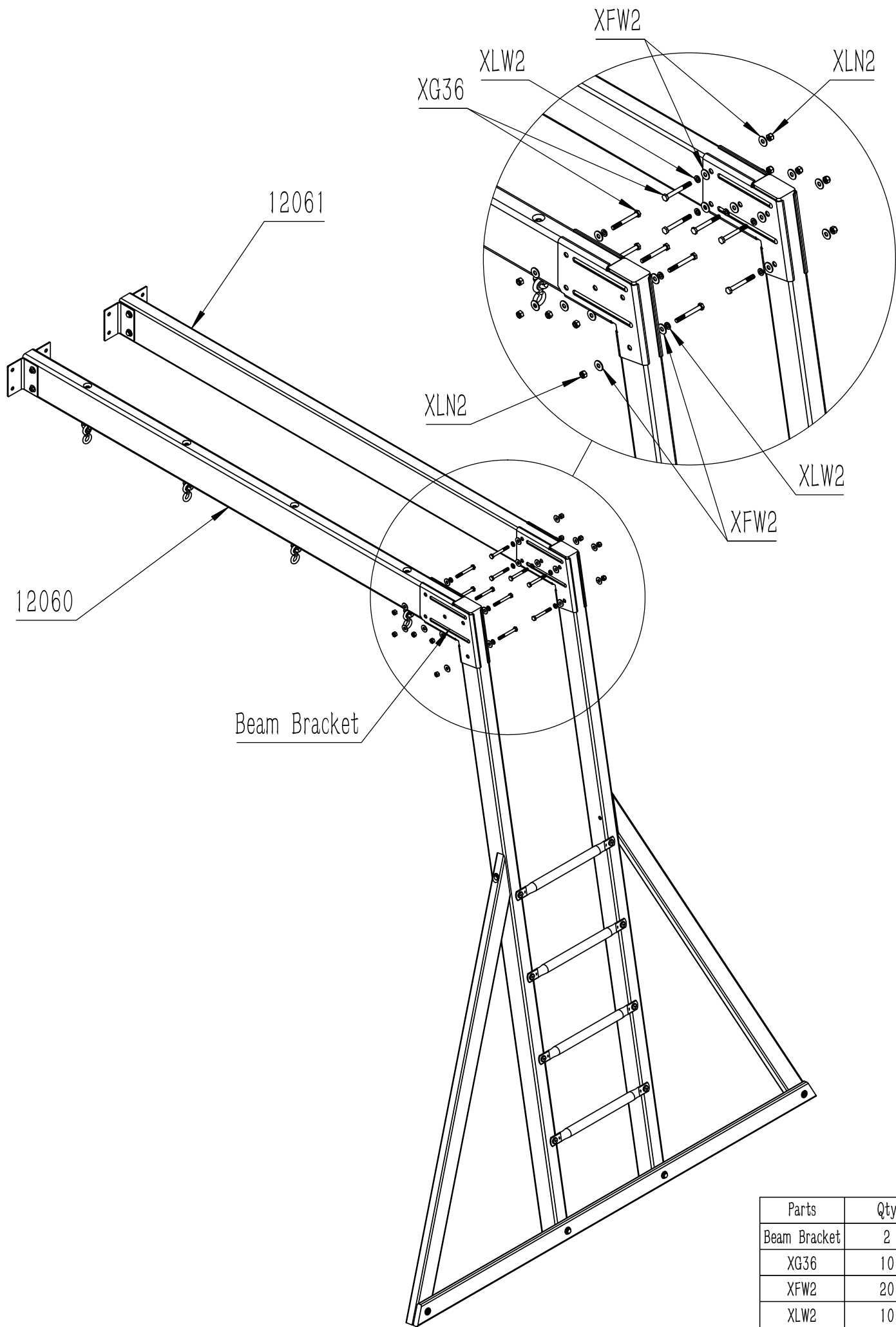

Parts	Qty
Beam Bracket	2
XG36	10
XFW2	20
XLW2	10
XLN2	10

Pre-drill each hole using a 1/8" drill bit for XWL3

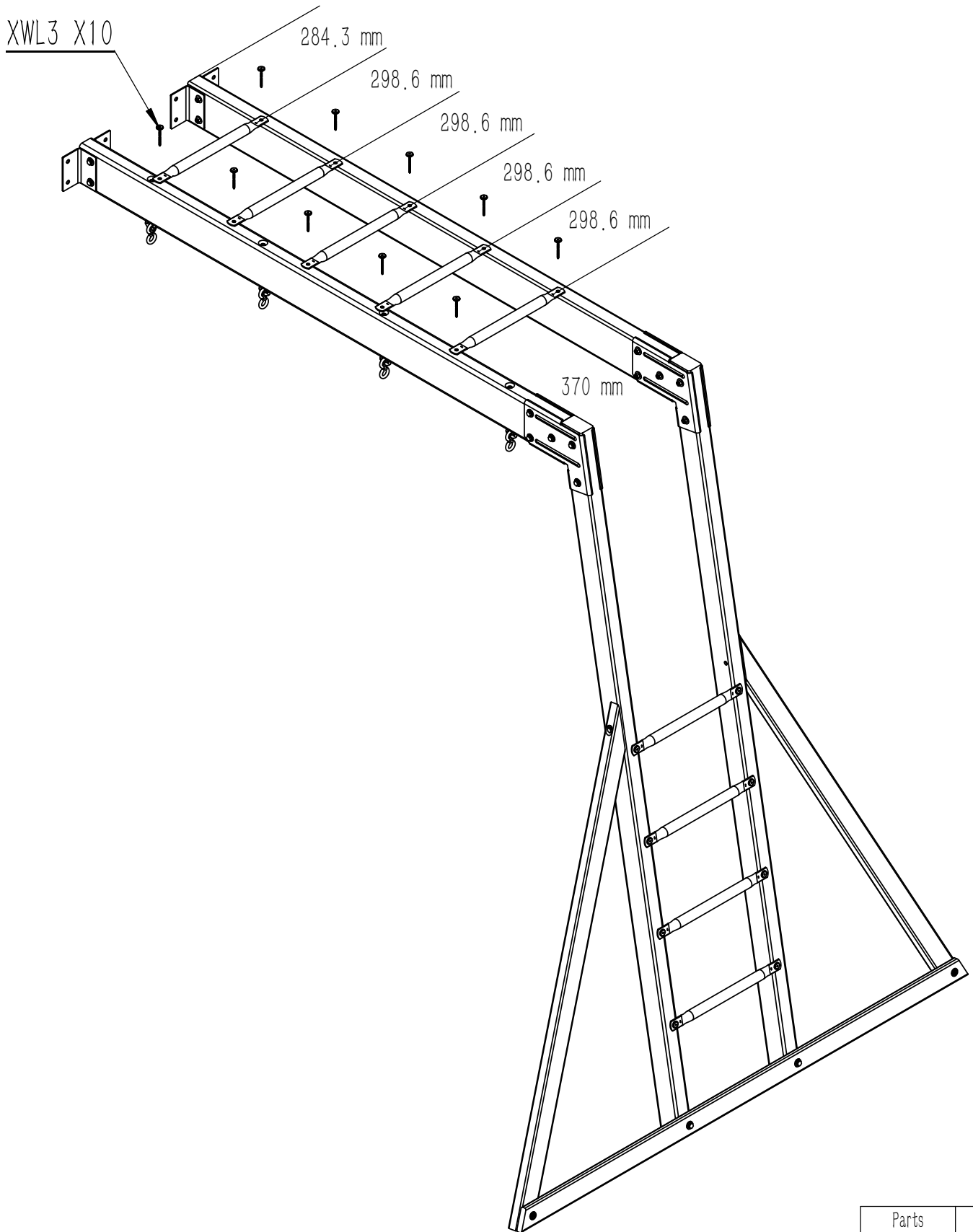

Parts	Qty
Monkey Bar	5
XWL3	10

Pre-drill each hole using a 1/8" drill bit for XWL3

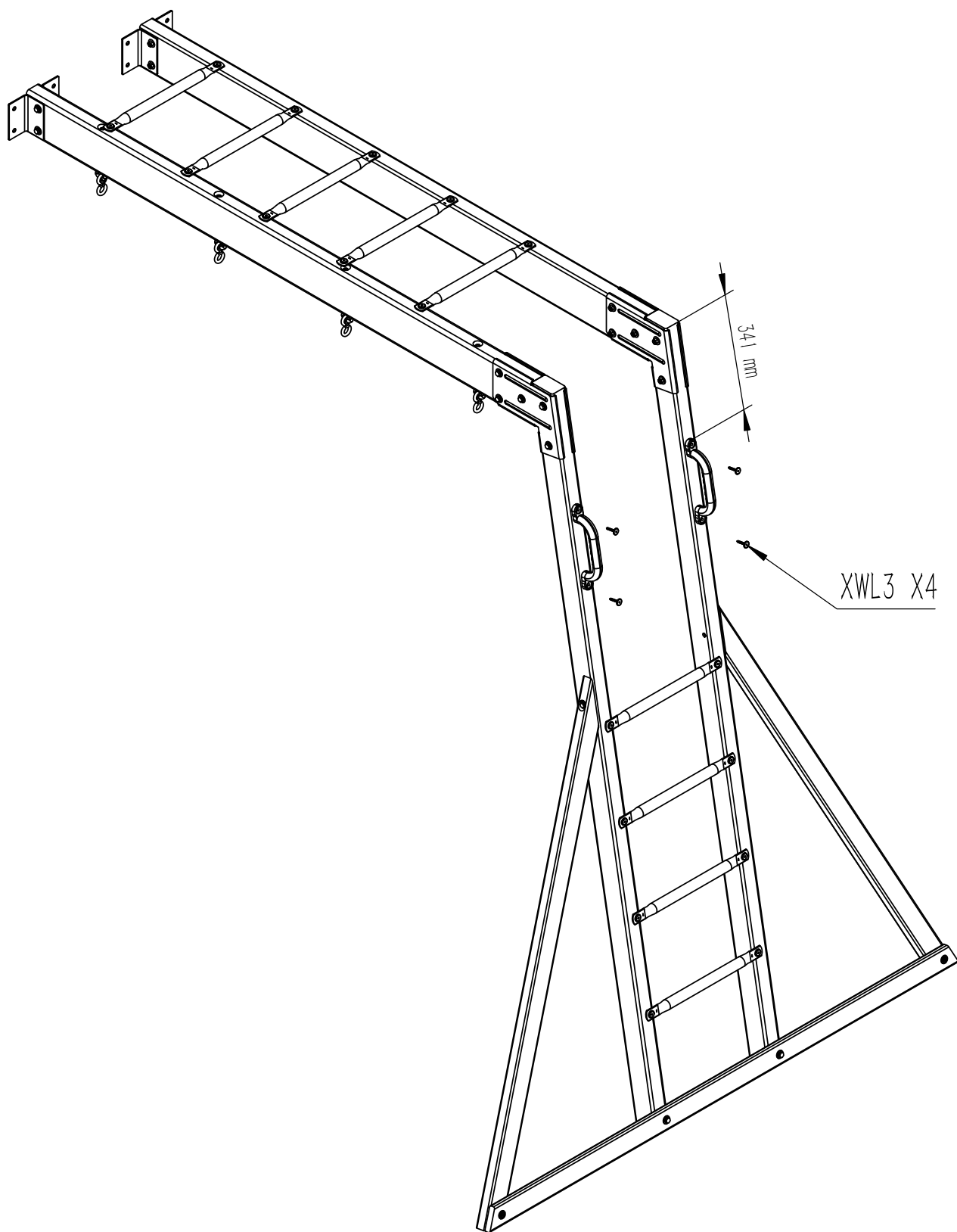

Parts	Qty
Handle	2
XWL3	4

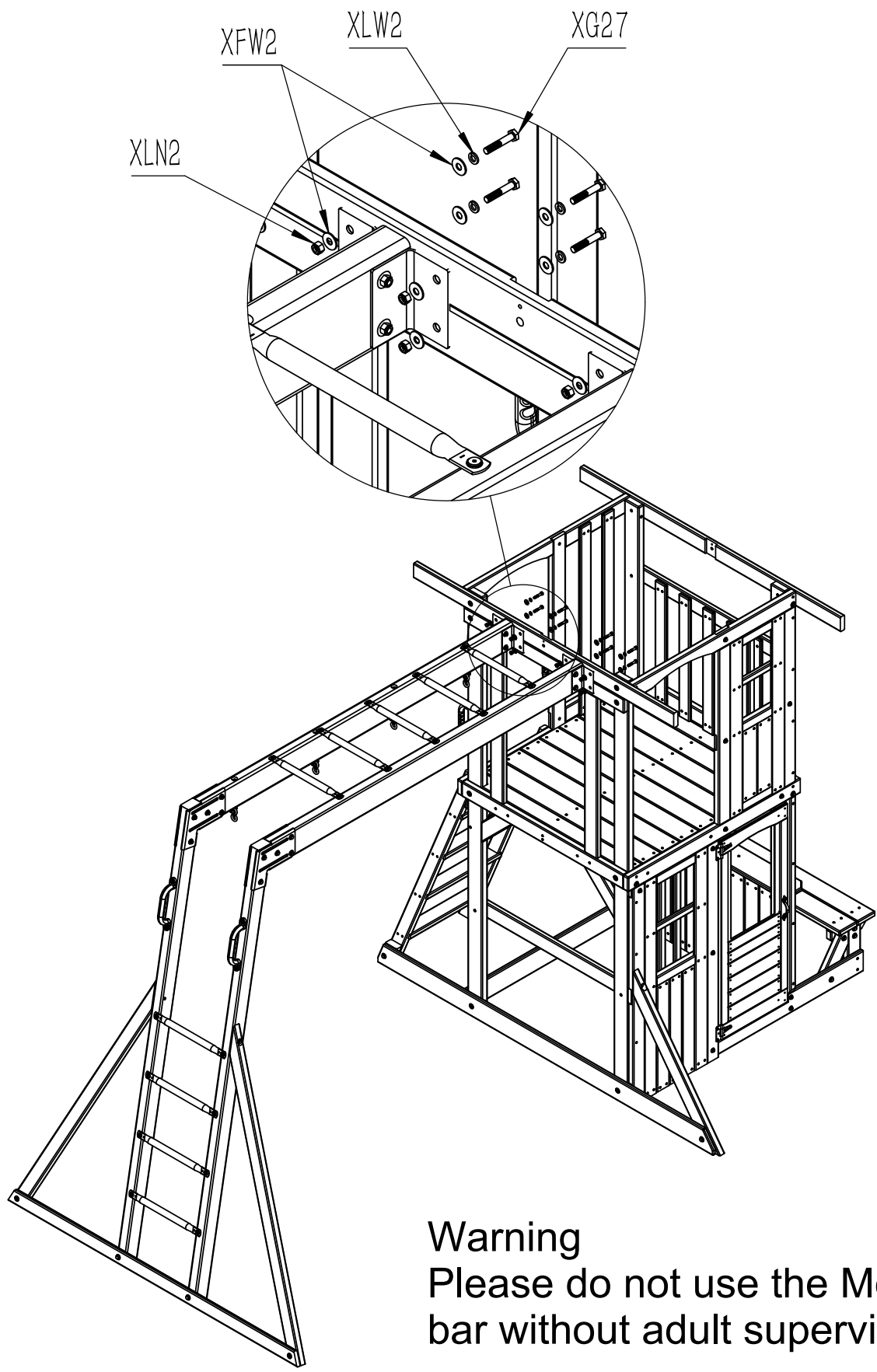

Warning
 Please do not use the Monkey
 bar without adult supervision.

Parts	Qty
XG27	8
XLW2	8
XFW2	16
XLN2	8

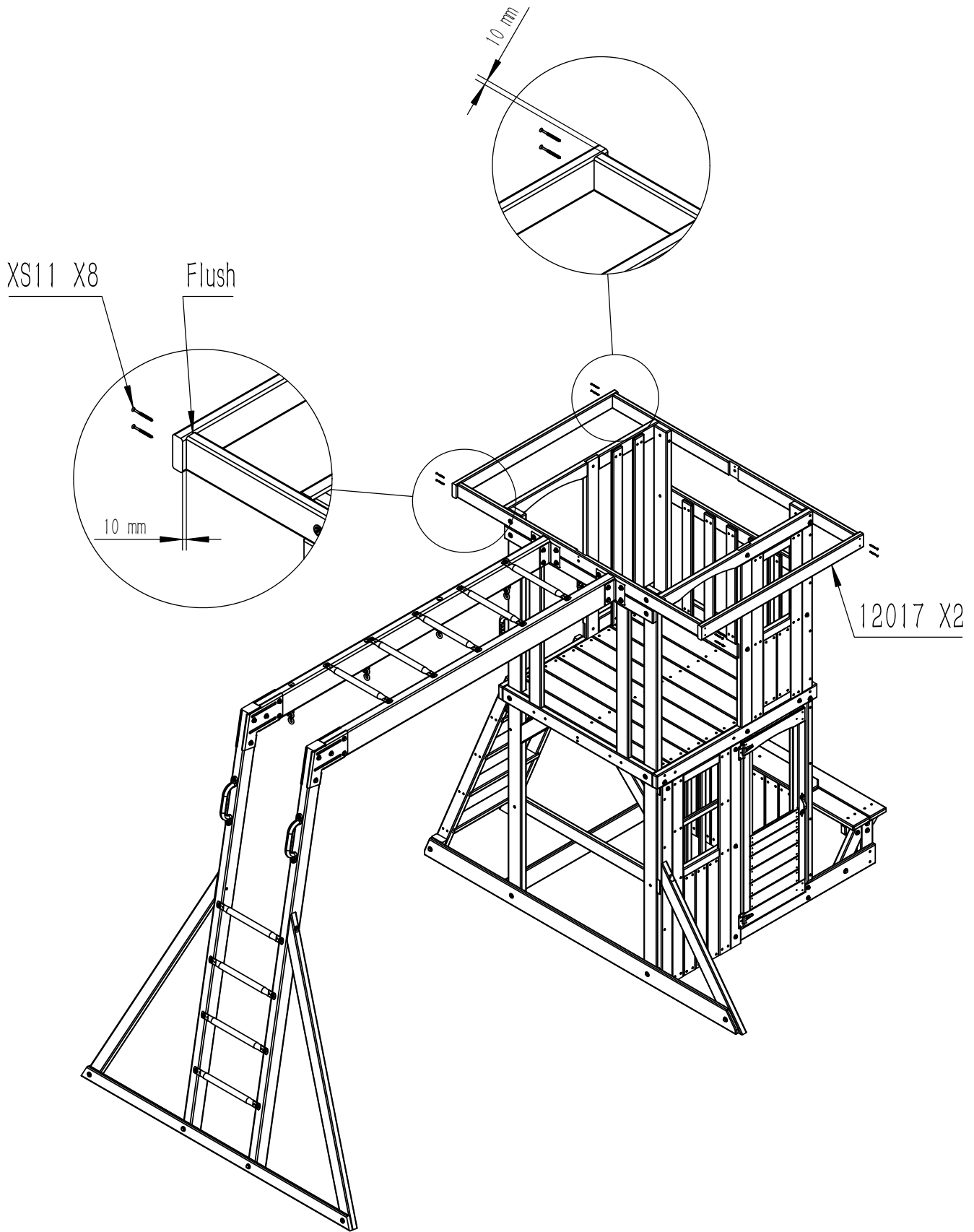

Parts	Qty
12017	2
XS11	8

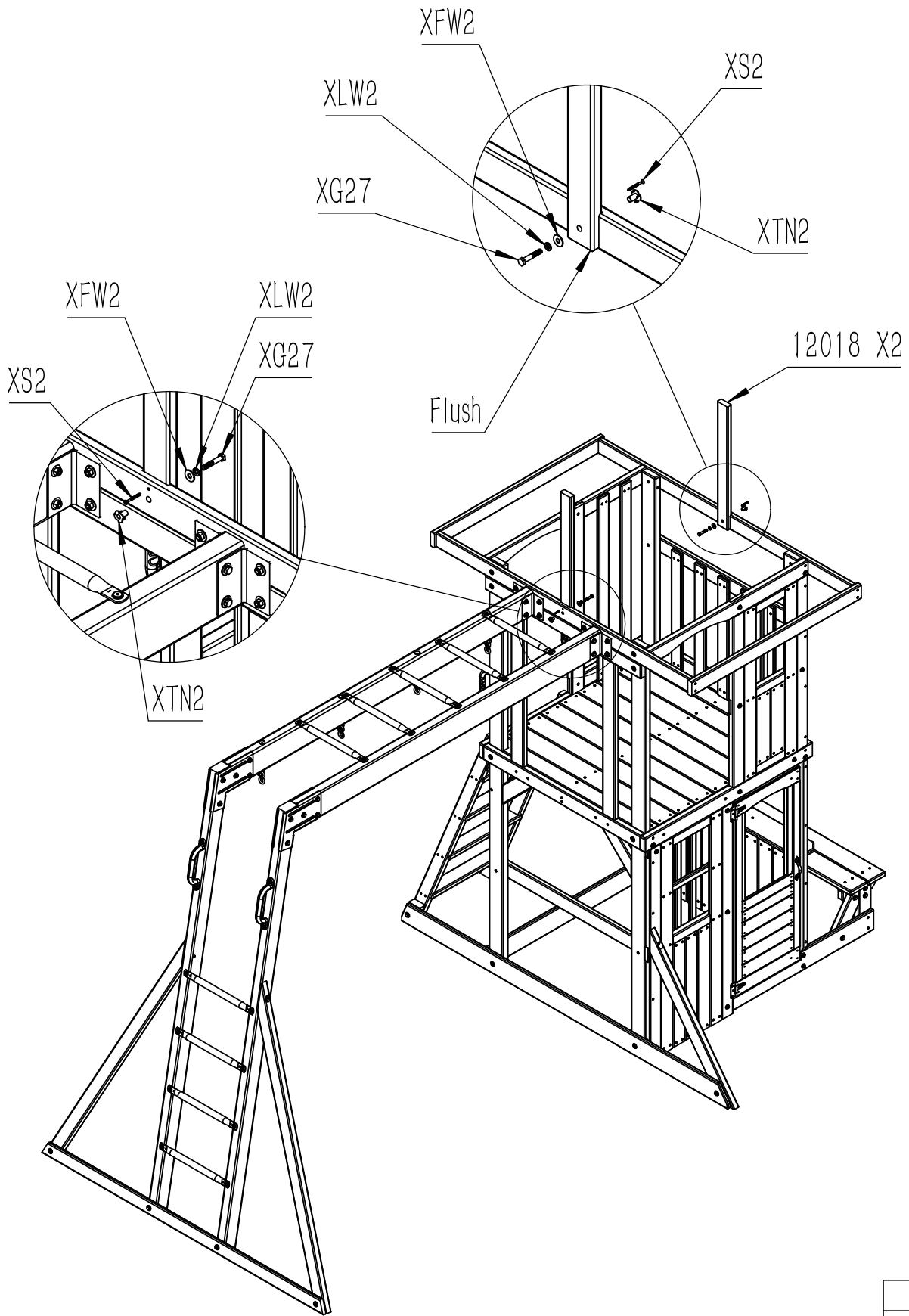

Parts	Qty
12018	2
XG27	2
XLW2	2
XFW2	2
XTN2	2
XS2	2

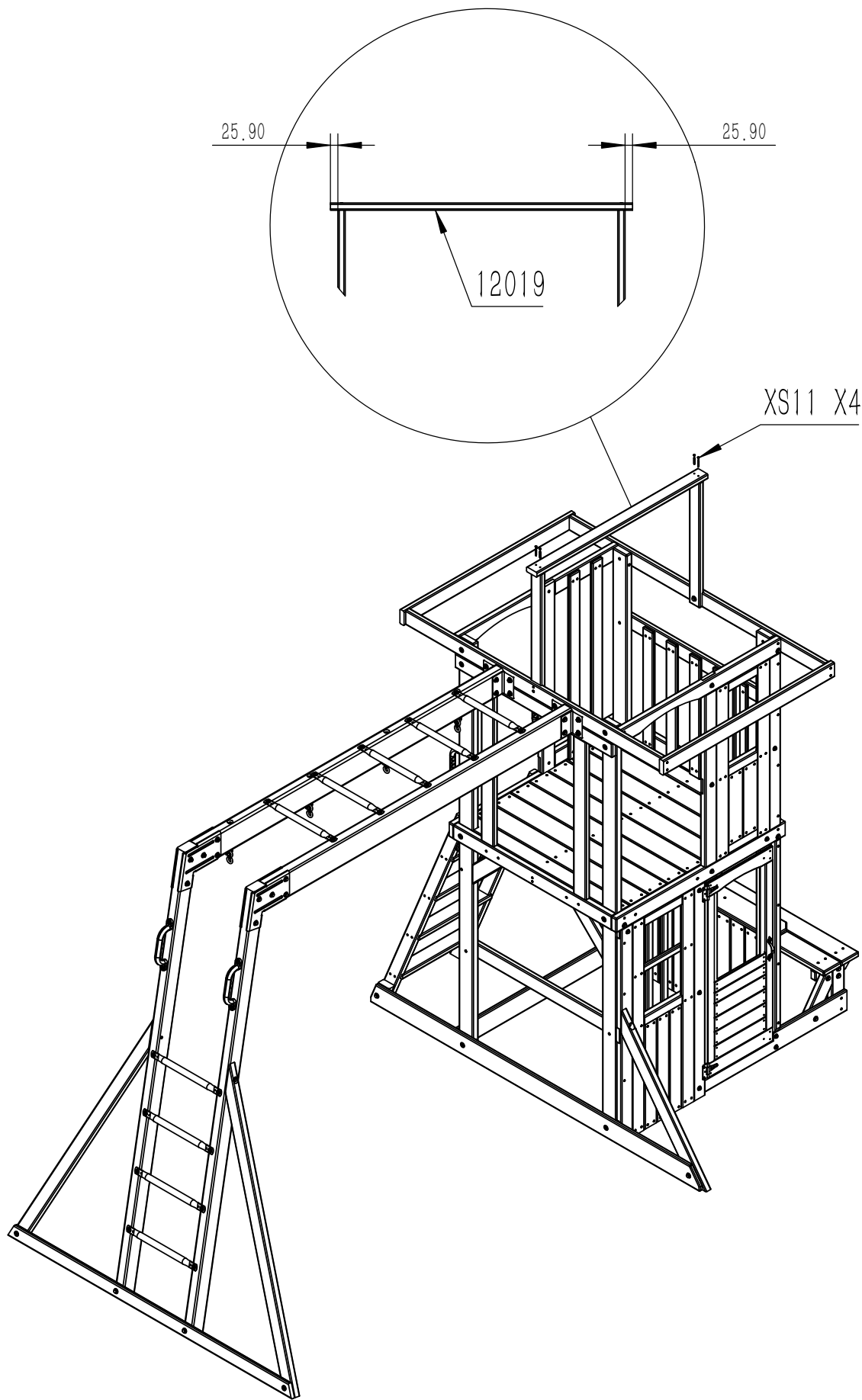

Parts	Qty
12019	1
XS11	4

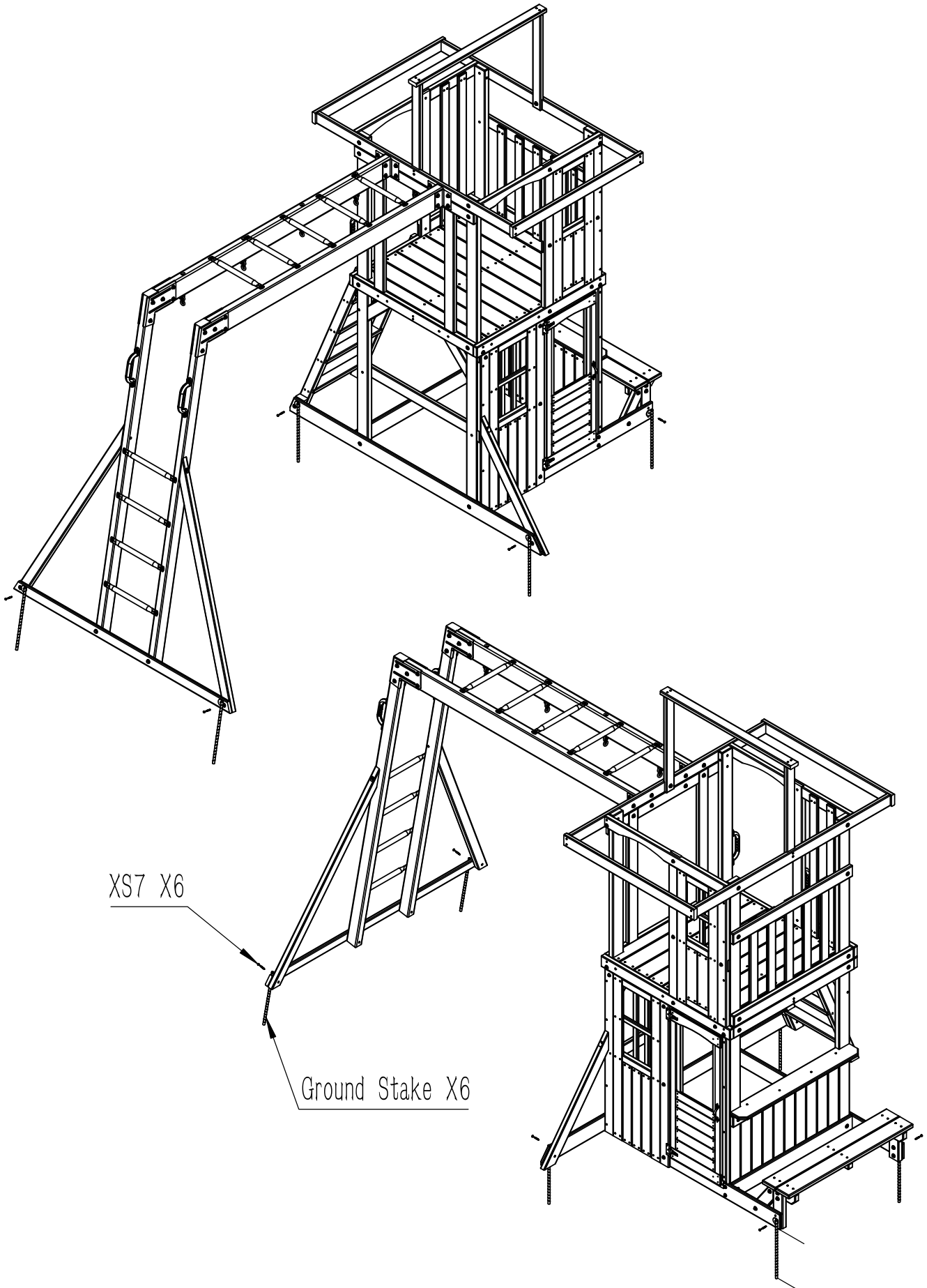

XS7 X6

Ground Stake X6

13" (330mm)
In Ground

Parts	Qty
Ground Stake	6
XS7	6

1. Open the flaps of the sail seat. Insert the four curved tubes into the sail seat through the flap openings, forming a circle. Do not remove the shock absorbing foam from the tubes.

2. a. Push the larger side of the tube over the smaller side of the tube. Repeat this for all tubes.

b. Close all four cover flaps.

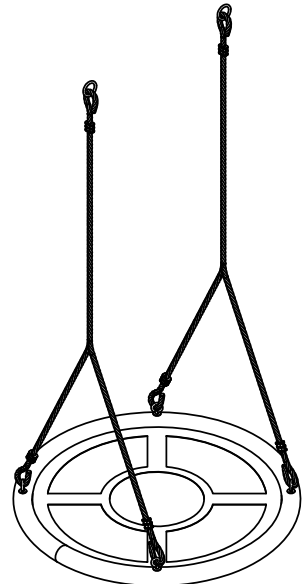

3. When the cover strips are closed, insert the eye bolts (from the end of the ropes) through the tubes. One eye bolt per tube. Use the

Nest Swing

Parts	Qty
Nest Swing	1

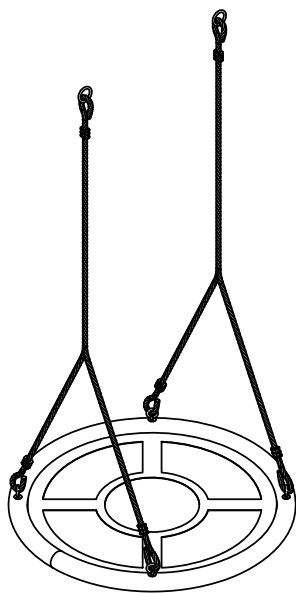
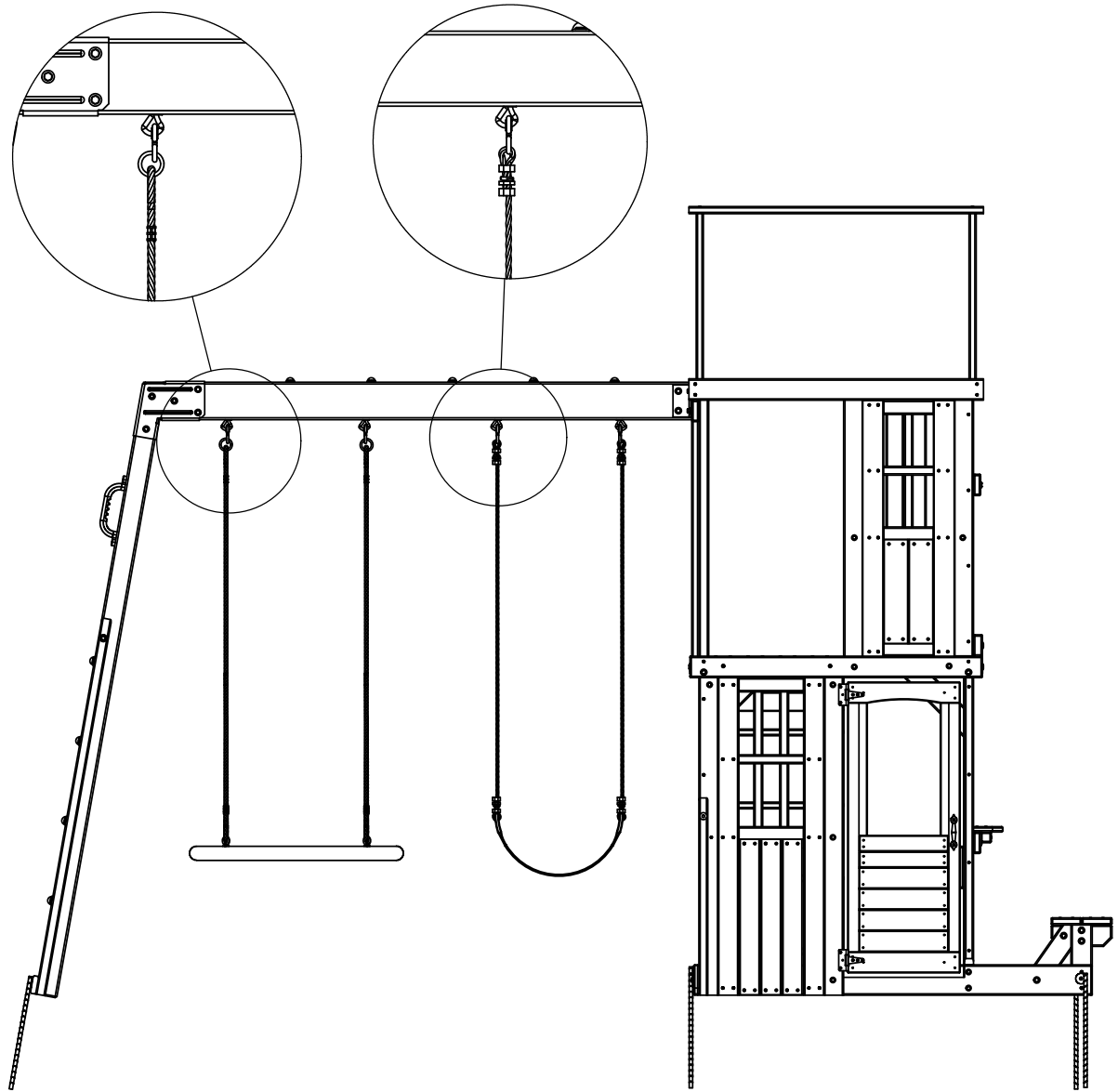

Nest Swing

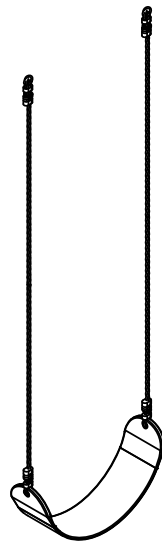

Swing

Parts	Qty
Swing	1

Screws are fixed between the floor board and 12005

XS7 X3

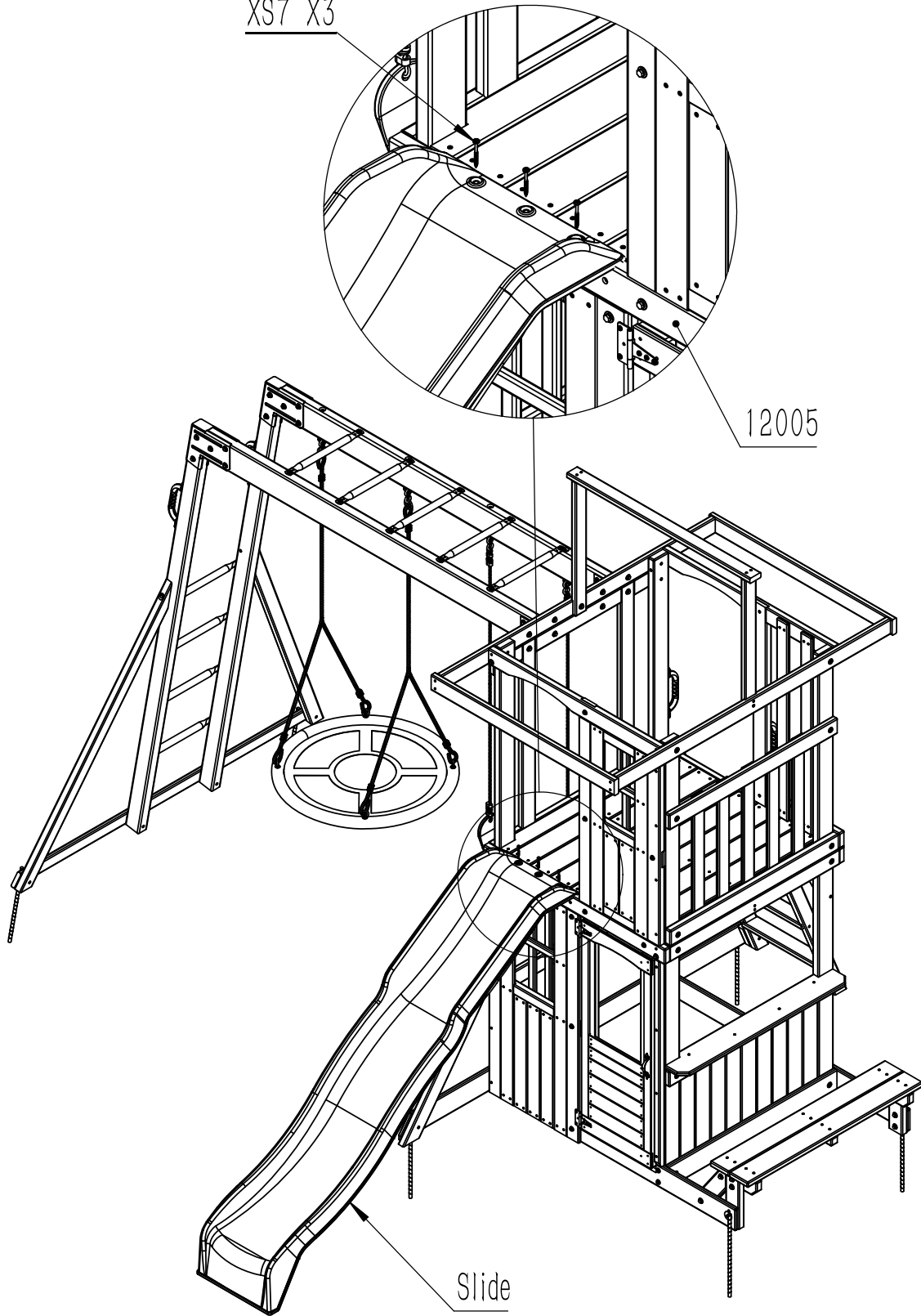

Make sure the slide is in the middle of the main body

Parts	Qty
Slide	1
XS7	3

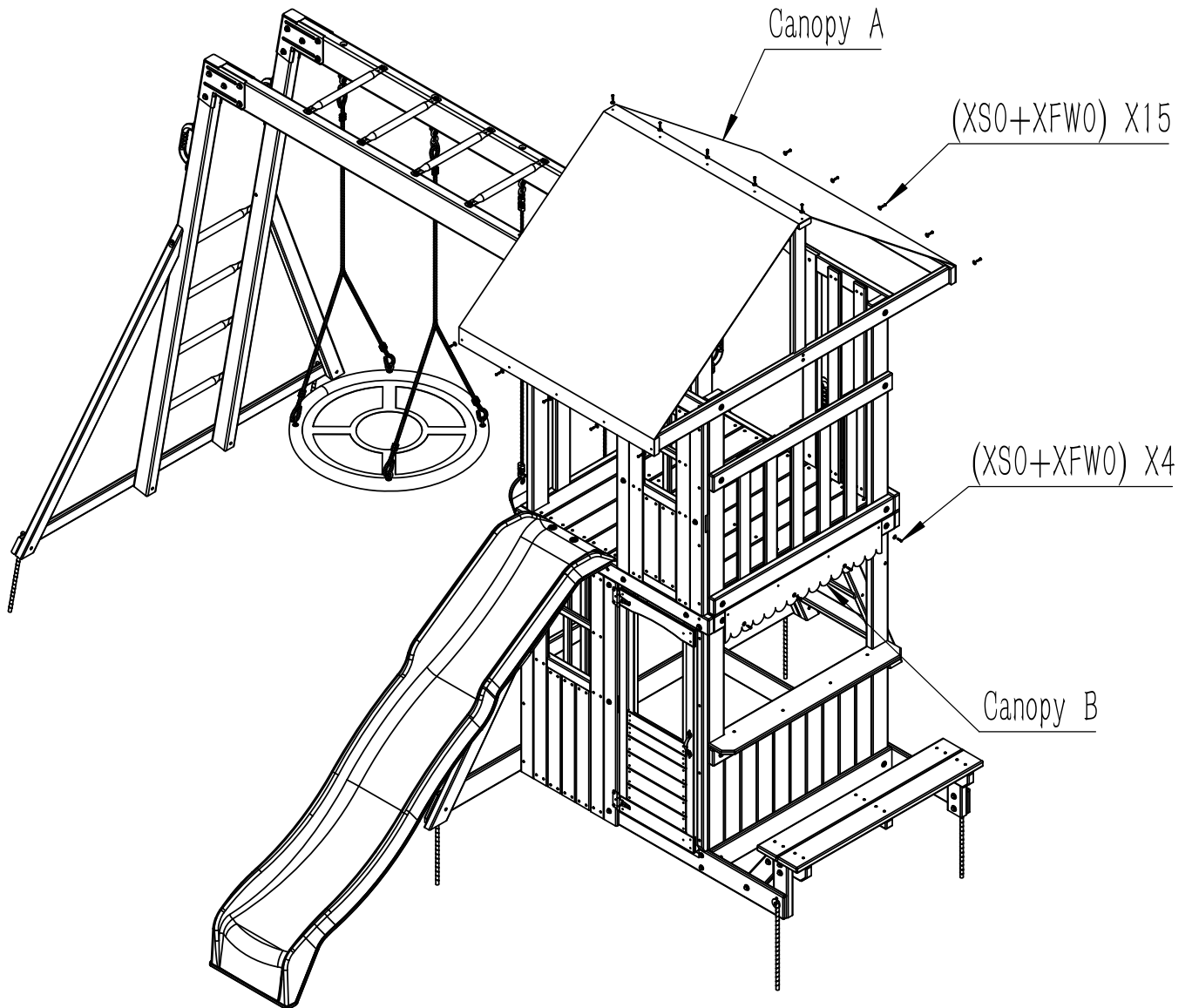
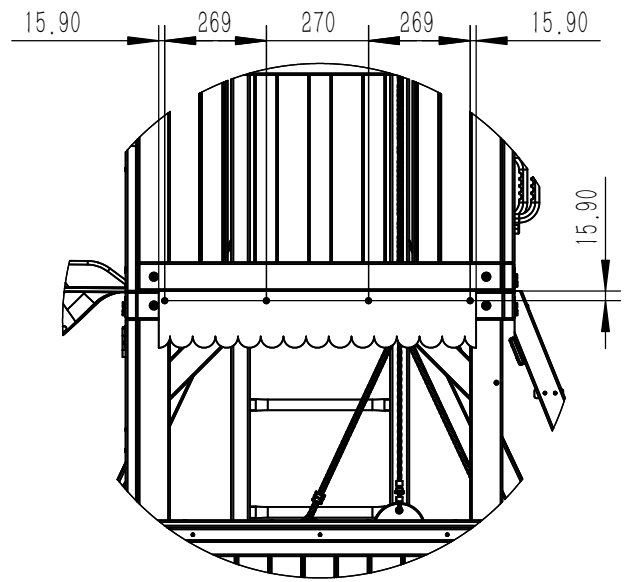
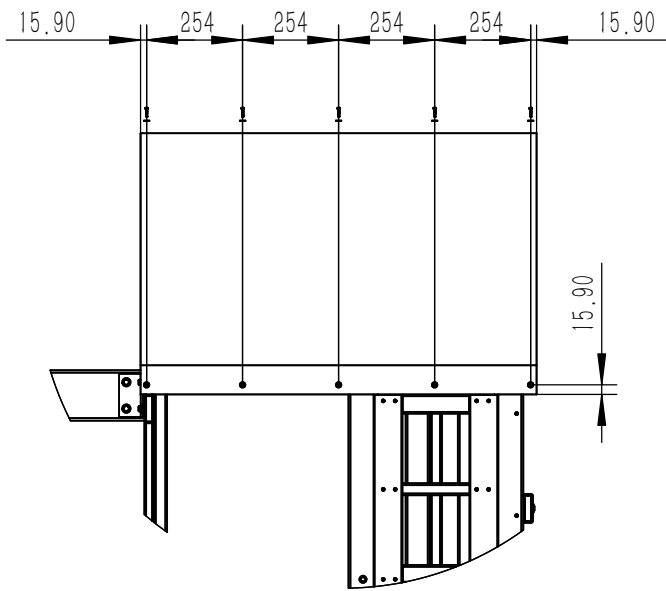

Parts	Qty
Canopy A	1
Canopy B	1
XS0	19
XFW0	19

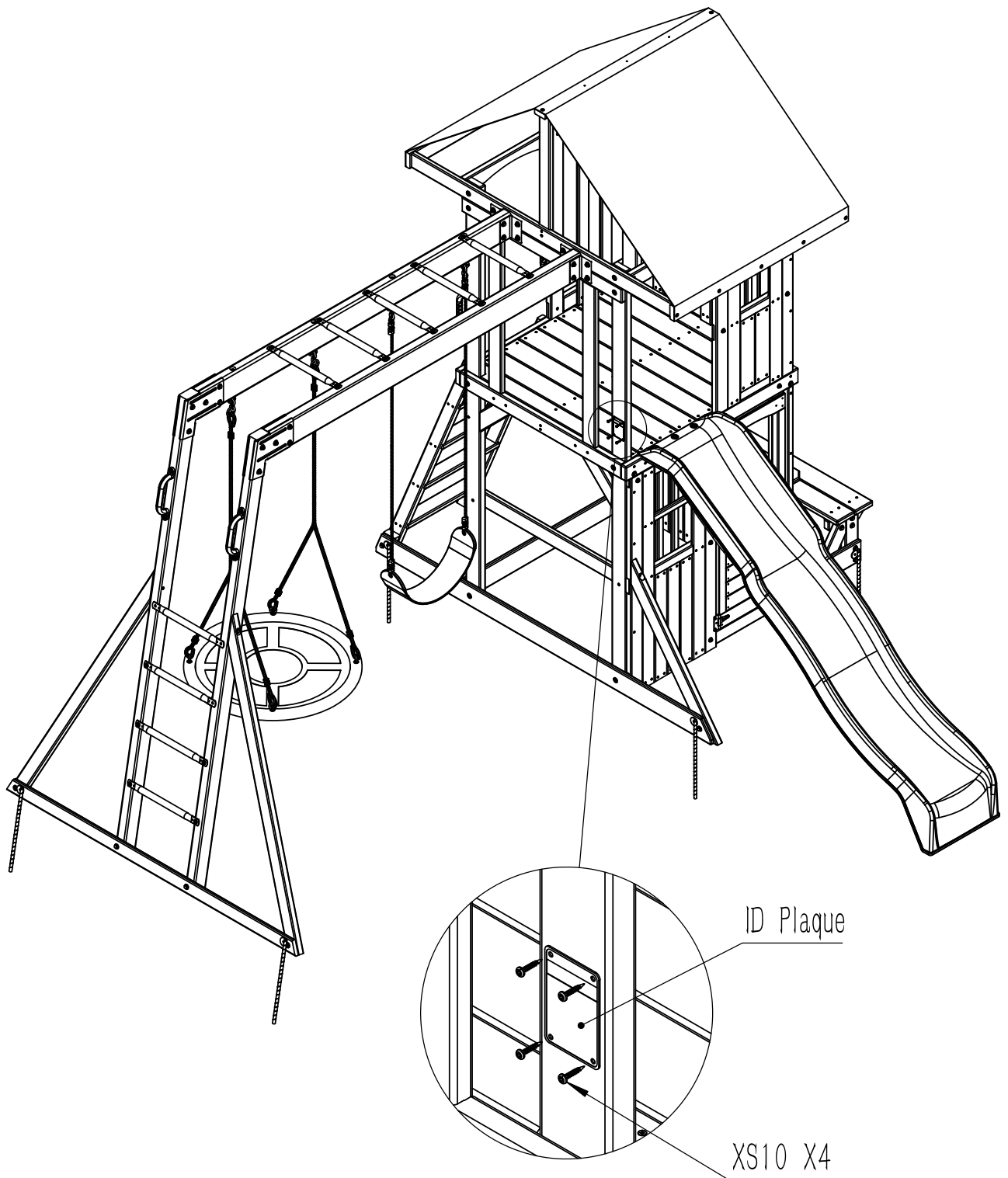

Parts	Qty
ID Plaque	1
XS10	4