

2 PERS.

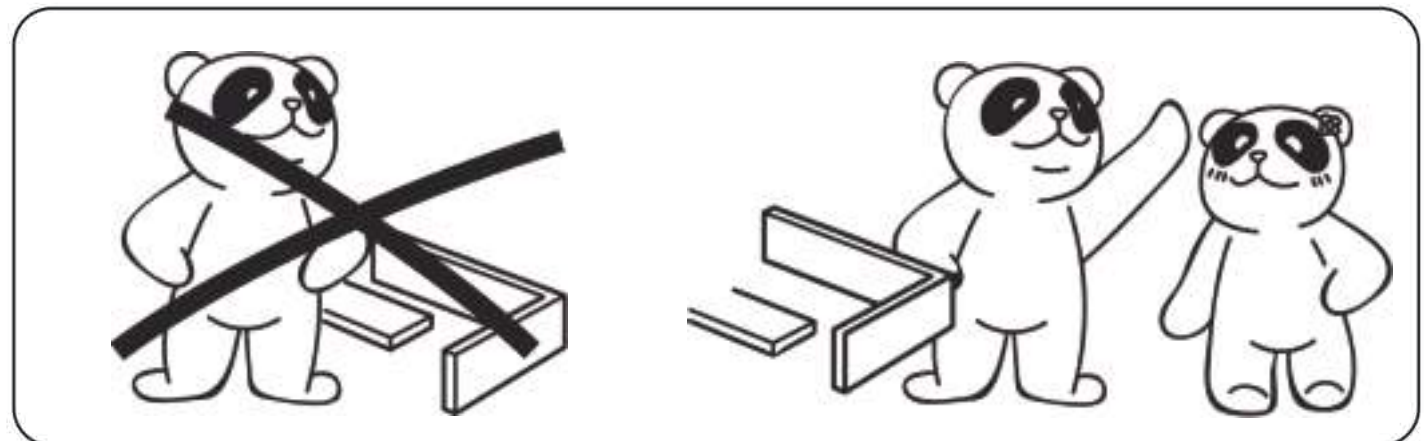

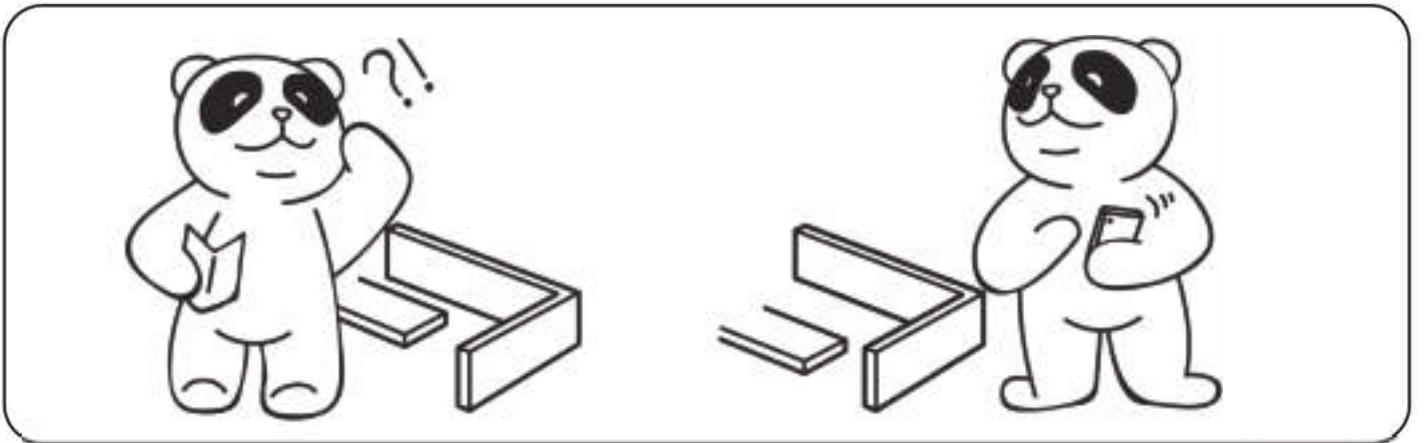
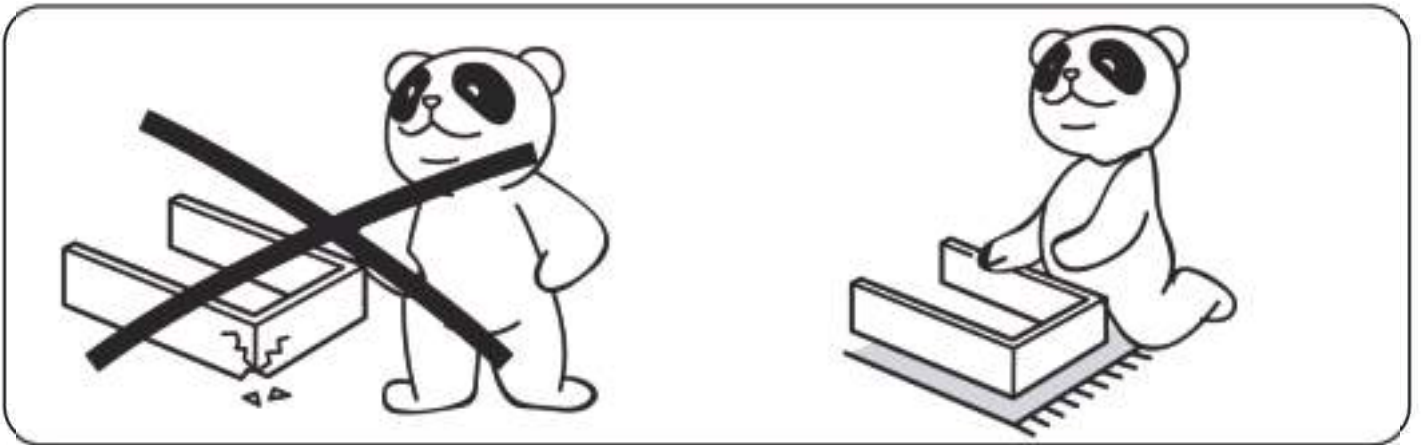
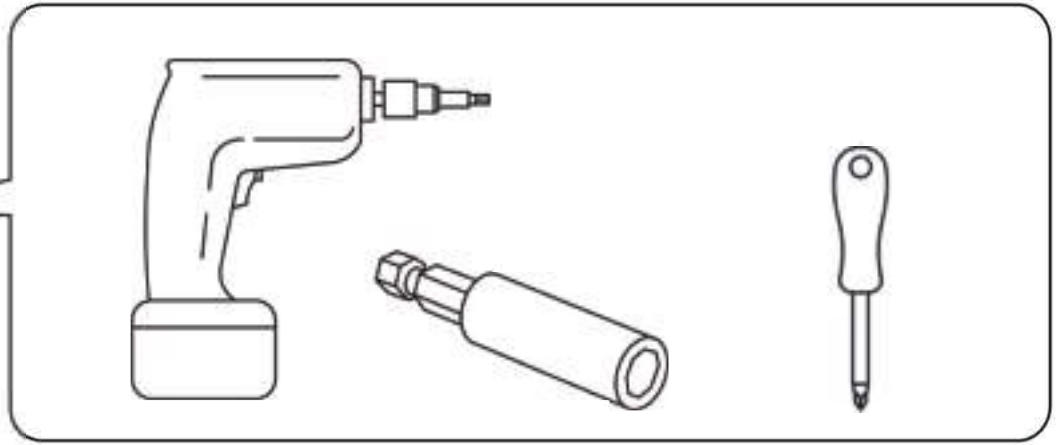

---

# Board Identification

Not actual size

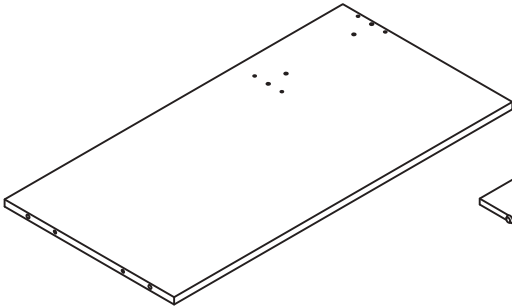

Ⓐ

Qty:1

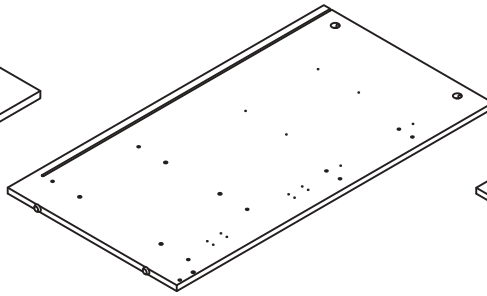

Ⓑ

Qty:1

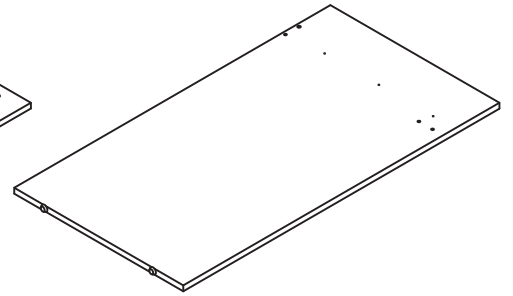

Ⓒ

Qty:1

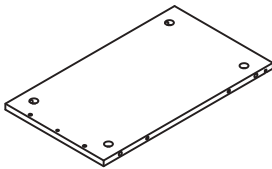

Ⓓ

Qty:2

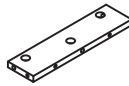

Ⓔ

Qty:2

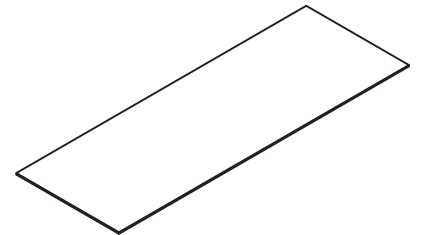

Ⓕ

Qty:1

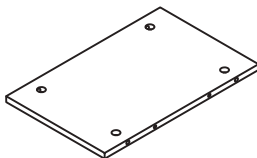

Ⓖ

Qty:1

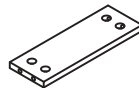

Ⓗ

Qty:4

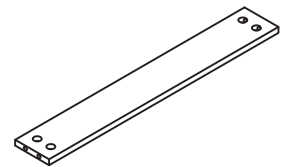

Ⓖ

Qty:1

---

# Board Identification

Not actual size

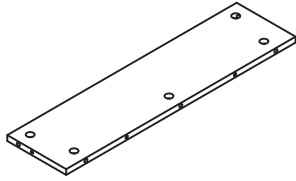

ⓐ

Qty:1

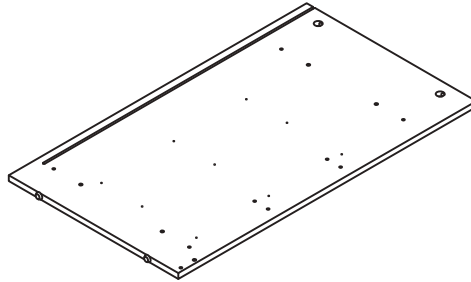

ⓑ

Qty:1

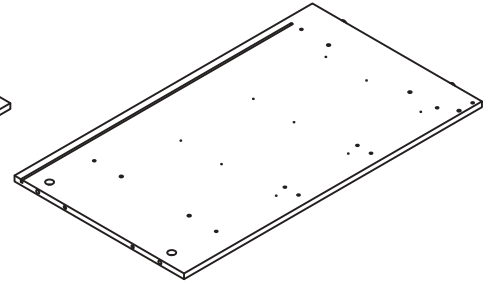

ⓒ

Qty:1

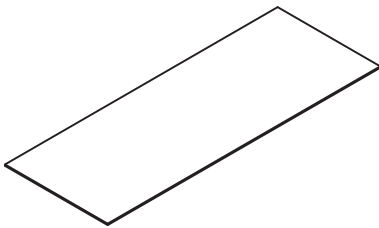

ⓓ

Qty:1

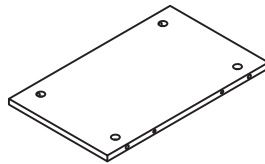

ⓔ

Qty:1

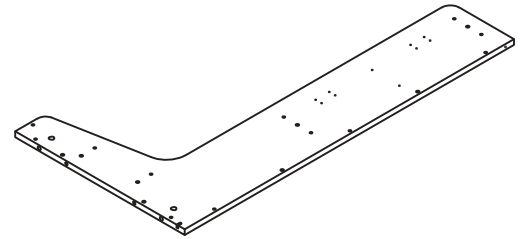

ⓕ

Qty:1

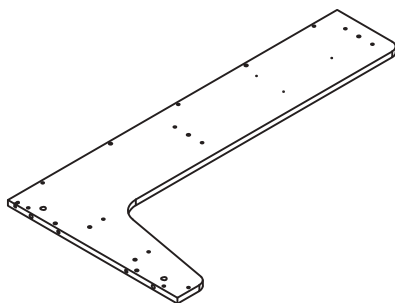

ⓖ

Qty:1

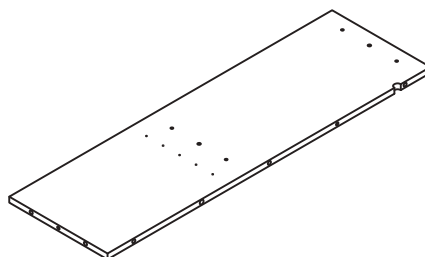

ⓗ

Qty:1

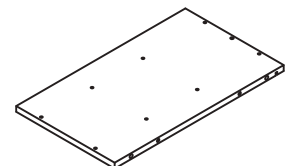

ⓘ

Qty:1

---

# Board Identification

Not actual size

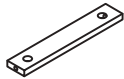

(S)

Qty:1

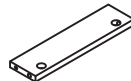

(T)

Qty:1

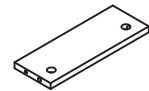

(U)

Qty:1

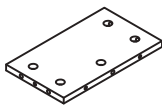

(V)

Qty:2

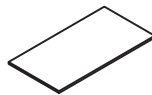

(W)

Qty:2

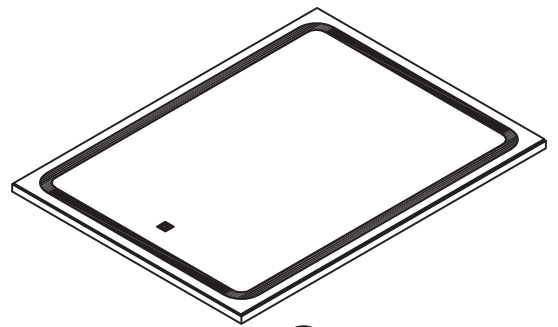

(X)

Qty:1

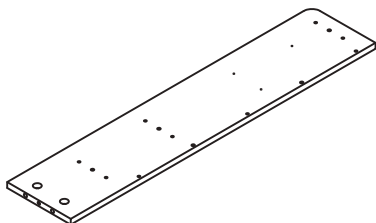

(Y)

Qty:1

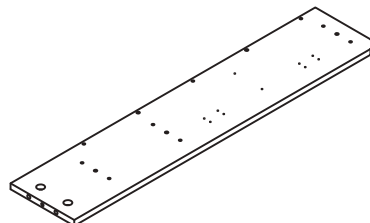

(Z)

Qty:1

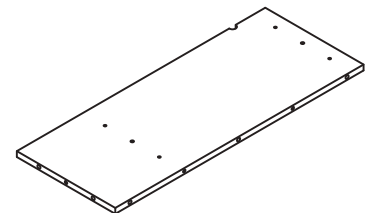

(AA)

Qty:1

---

# Board Identification

Not actual size

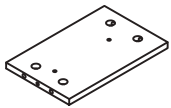

Ⓟ

Qty:1

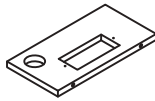

Ⓞ

Qty:1

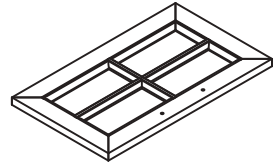

Ⓞ

Qty:2

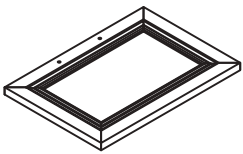

Ⓞ

Qty:1

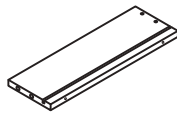

Ⓞ

Qty:5

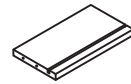

Ⓞ

Qty:5

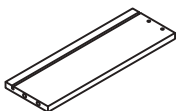

Ⓞ

Qty:5

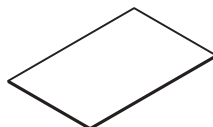

Ⓞ

Qty:5

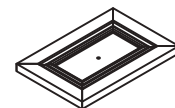

Ⓞ

Qty:5

---

# Board Identification

Not actual size

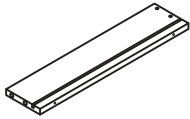

ⓀⓀ

Qty:1

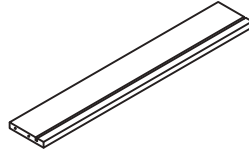

ⓁⓁ

Qty:1

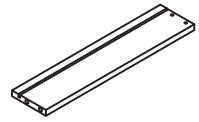

ⓂⓂ

Qty:1

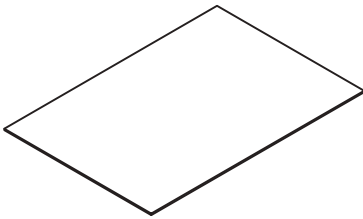

ⓃⓃ

Qty:1

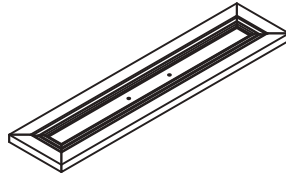

ⓄⓄ

Qty:1

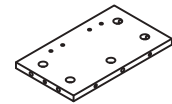

ⓅⓅ

Qty:1

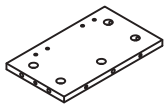

ⓆⓆ

Qty:1

# Part List

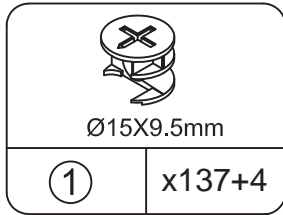

CAM LOCK

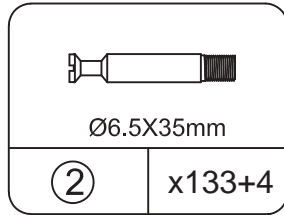

CAM BOLT

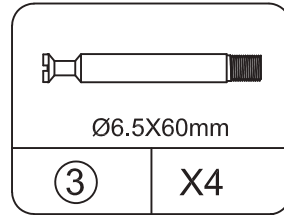

CAM BOLT

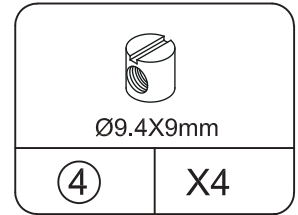

CAM LOCK

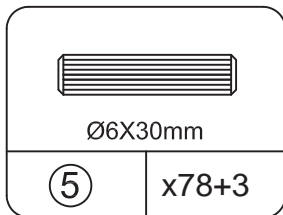

WOOD DOWEL

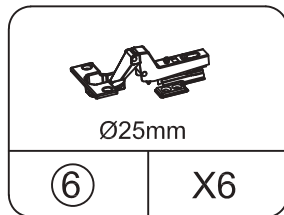

HINGE

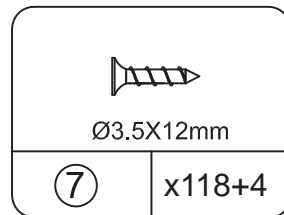

SCREW

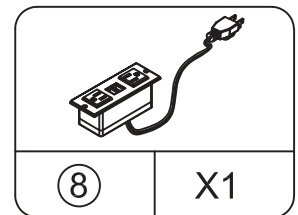

POWER STRIP

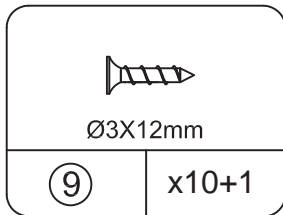

SCREW

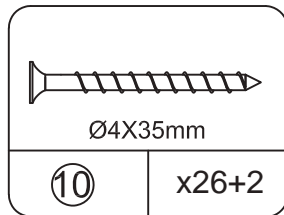

SCREW

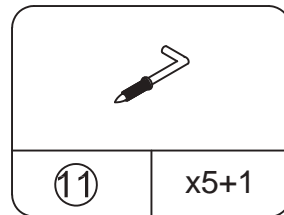

HOOKING



SHELF SUPPORT

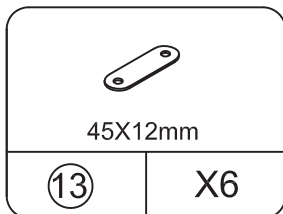

IRON SHEETS

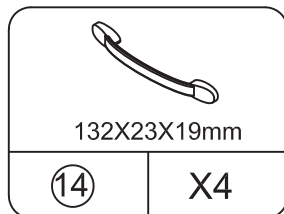

HANDLE

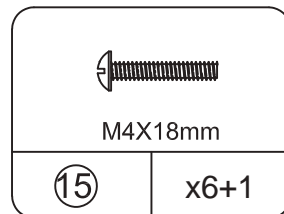

SCREW

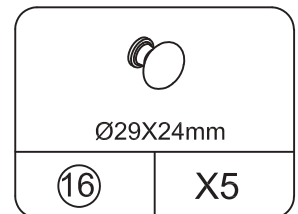

HANDLE

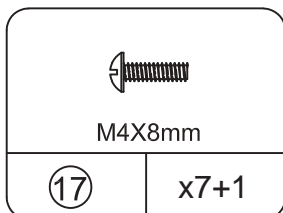

SCREW

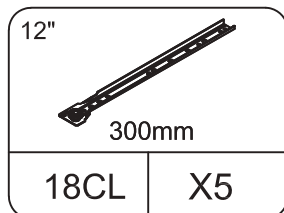

LEFT CABINET MEMBER

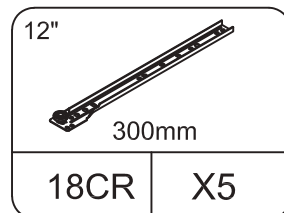

RIGHT CABINET MEMBER

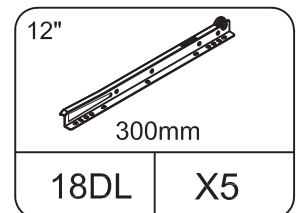

LEFT DRAWER RUNNER

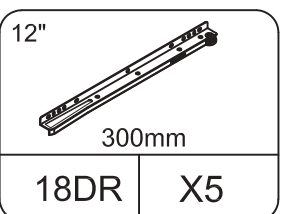

RIGHT DRAWER RUNNER

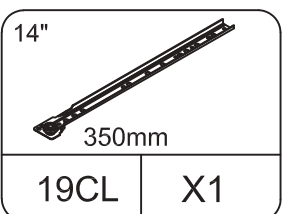

LEFT CABINET MEMBER

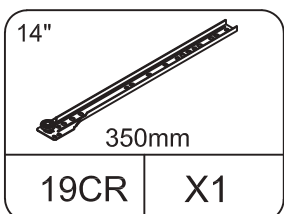

RIGHT CABINET MEMBER

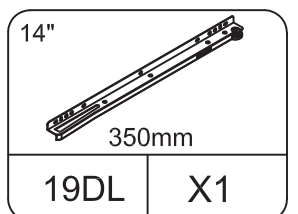

LEFT DRAWER RUNNER

# Part List

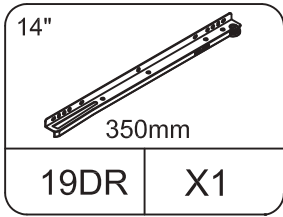

RIGHT DRAWER RUNNER

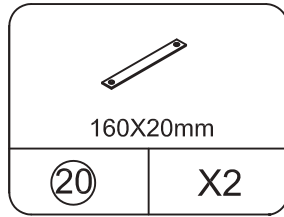

HIPPING RESTRAINT  
HARDWARE KIT

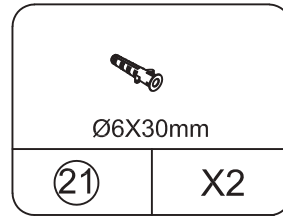

EXPANSION TUBE

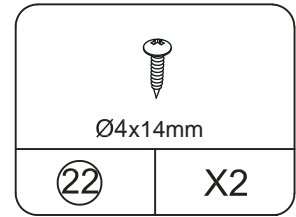

SCREW

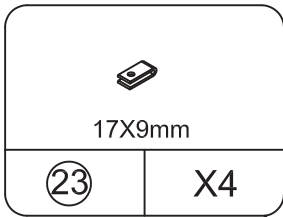

BUCKLES

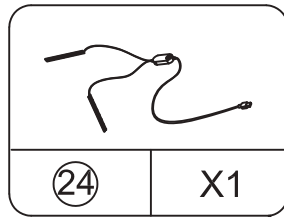

LIGHT BULB

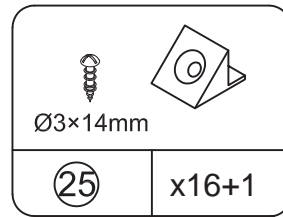

BACK PANEL BUCKLE

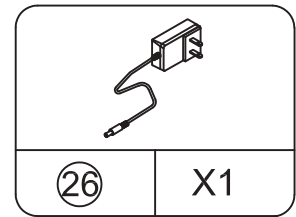

POWER PLUG

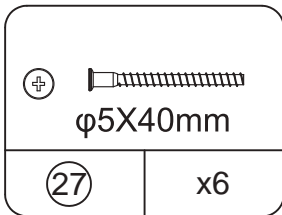

BUCKLES

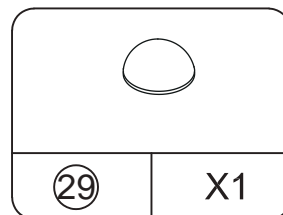
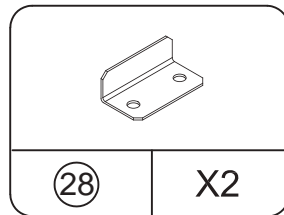

## Cam Lock Fastening System

Insert the cam bolt into the hole first, then insert the cam lock and lock it.

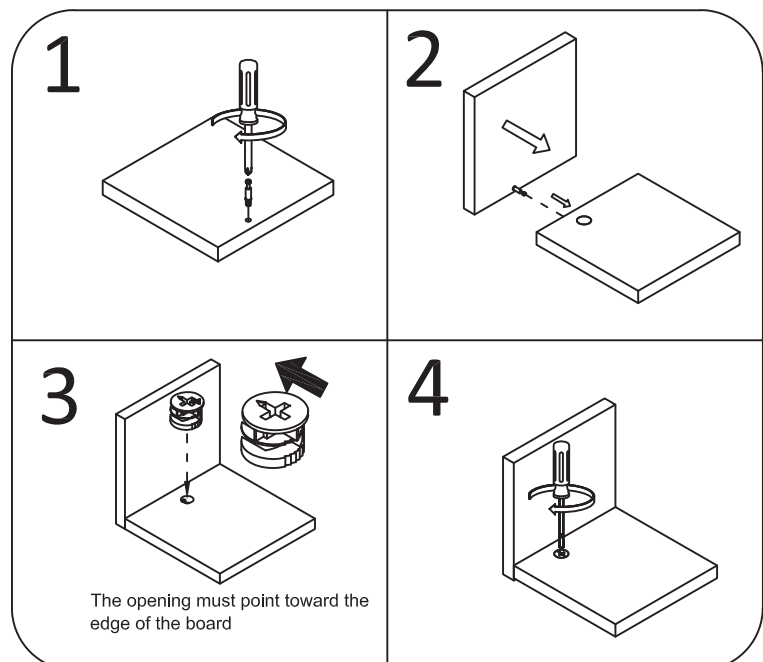

# Board Identification

Not actual size

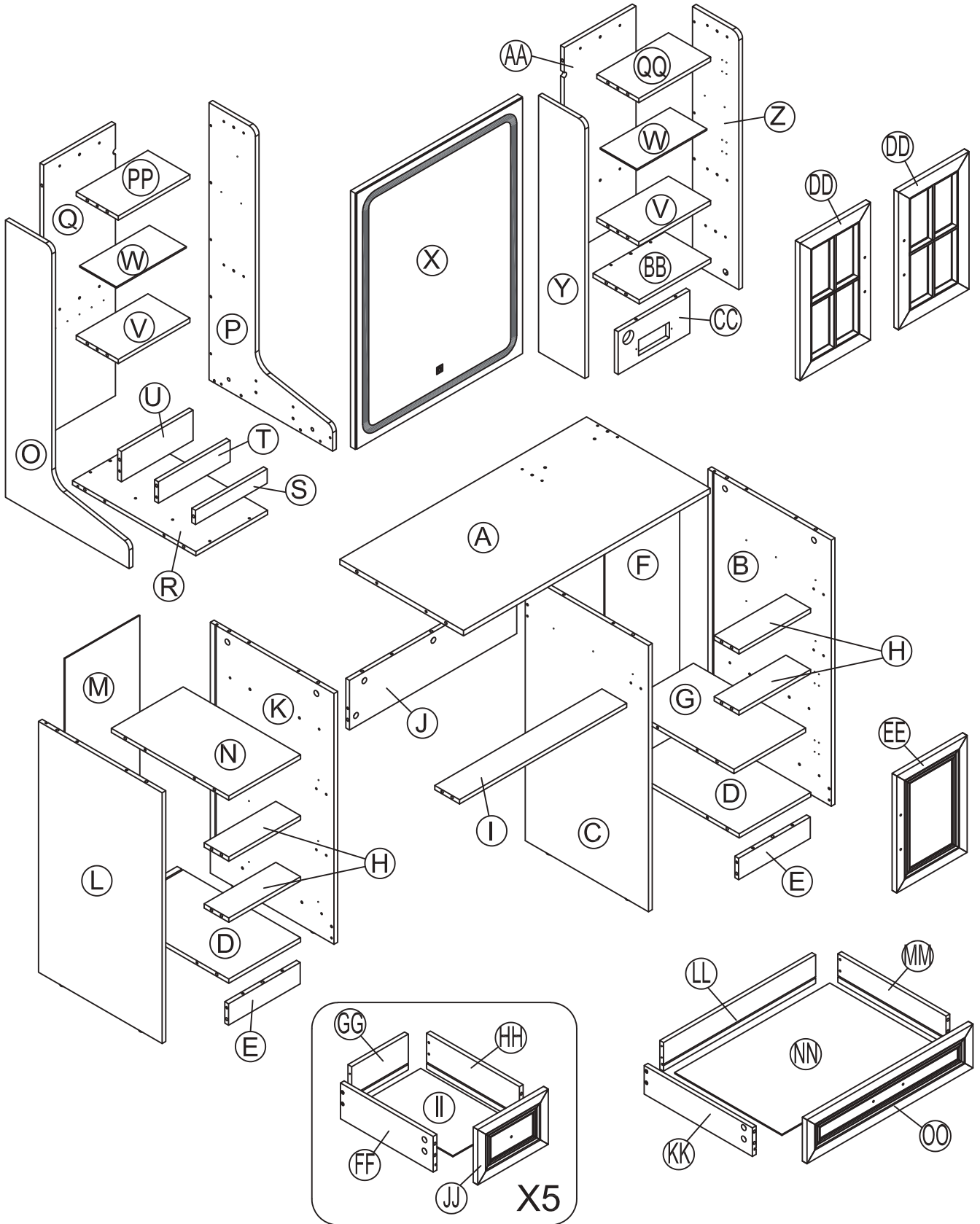

# STEP1

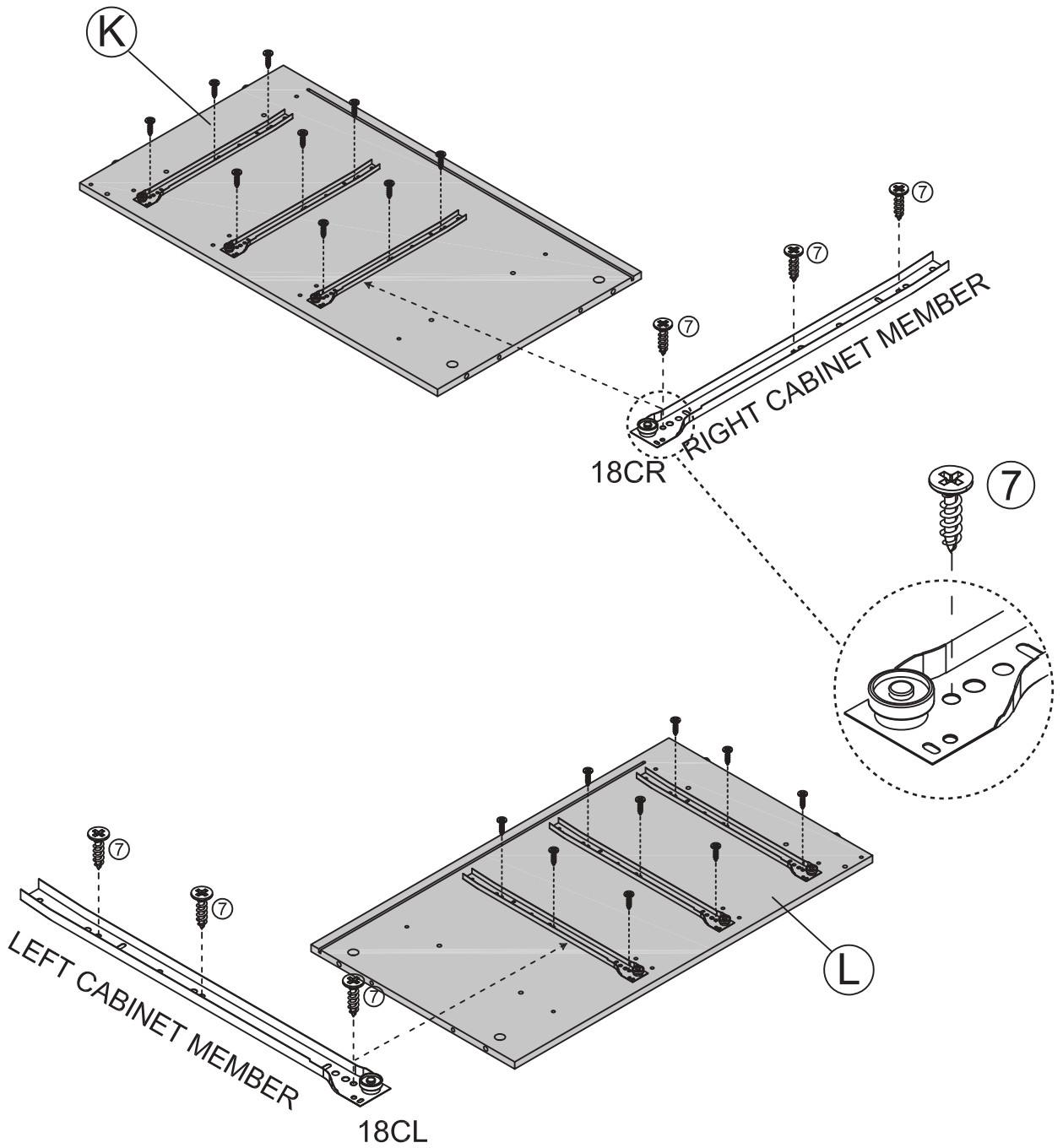
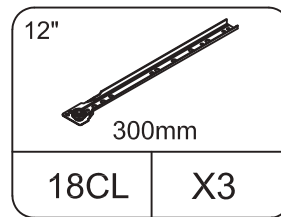
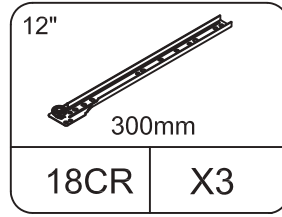
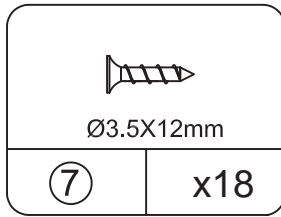



# STEP3

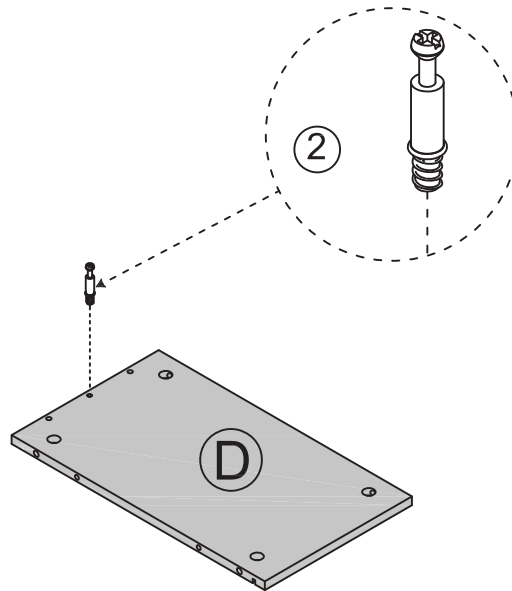
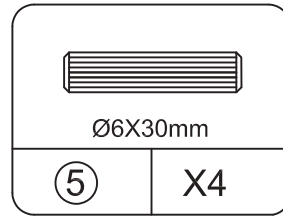
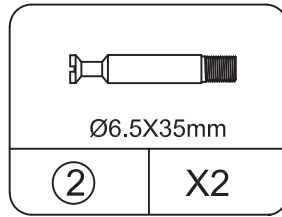
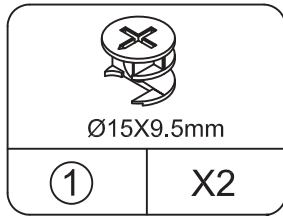

## EDGE BANDING

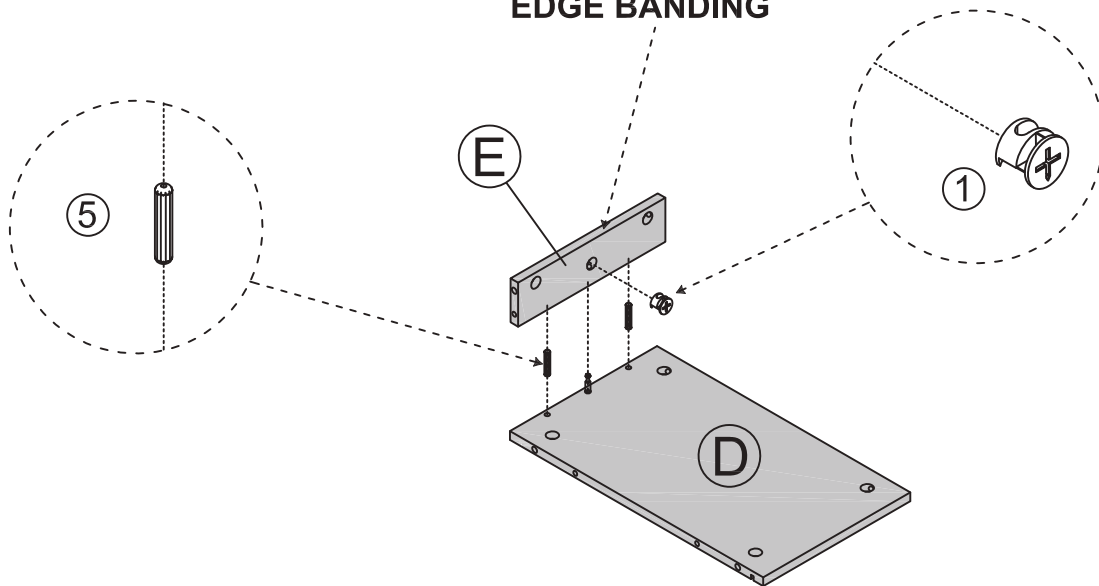

Insert the cam bolt into the hole first, then insert the cam lock and lock it.

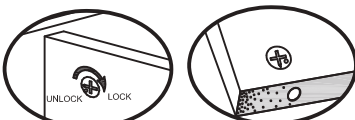

Proper orientation of CAM LOCK

# X2

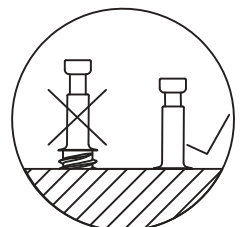

# STEP 4

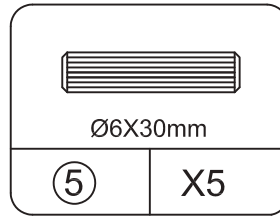
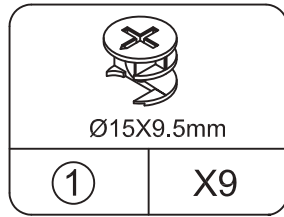

EDGE BANDING

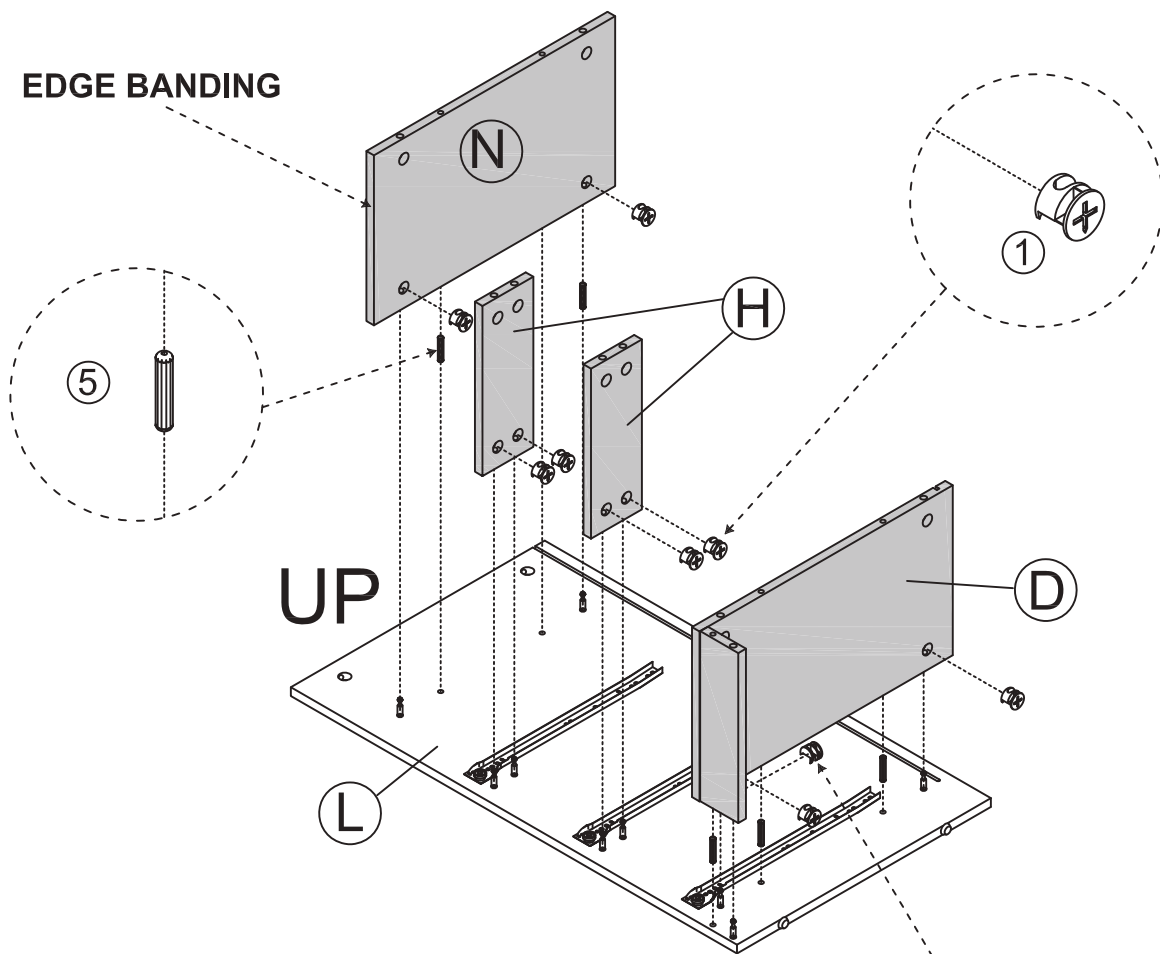

Insert the cam bolt into the hole first, then insert the cam lock and lock it.

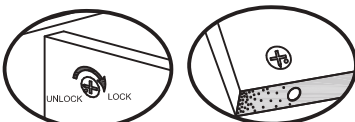

Proper orientation of CAM LOCK

# STEP 5

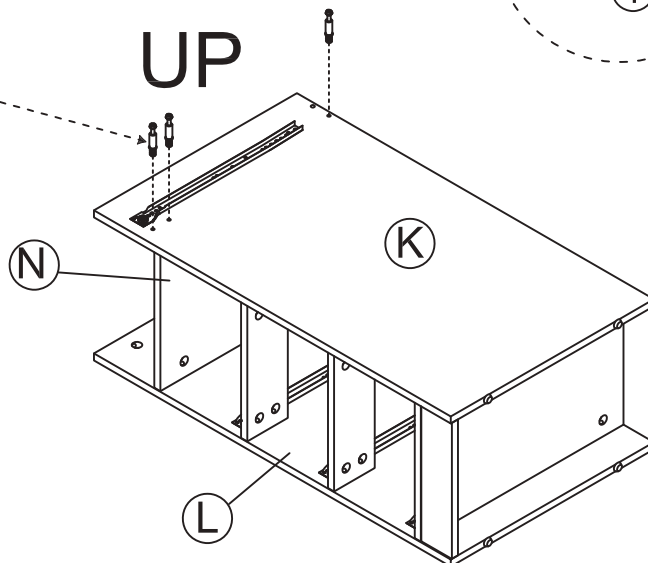
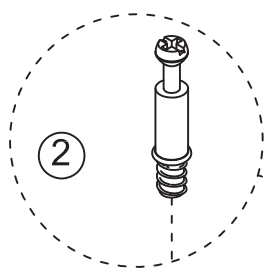
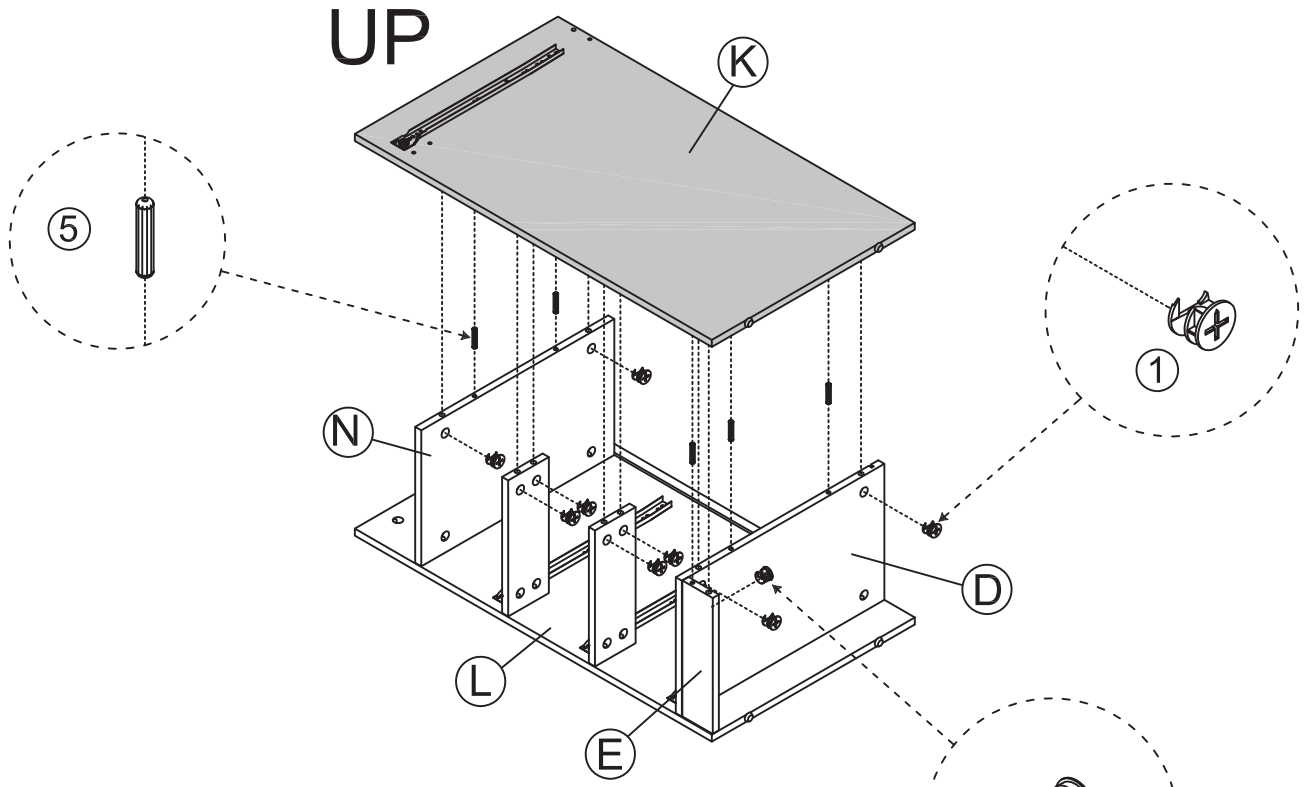
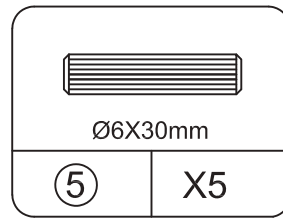
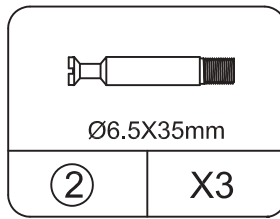
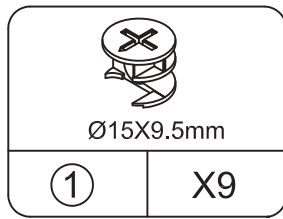

Insert the cam bolt into the hole first, then insert the cam lock and lock it.

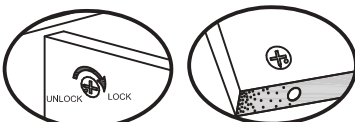

Proper orientation of CAM LOCK

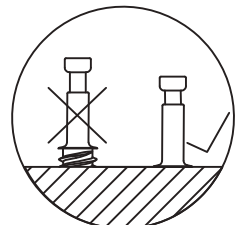

# STEP 6

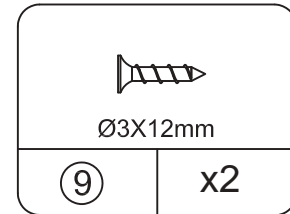
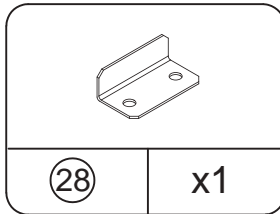
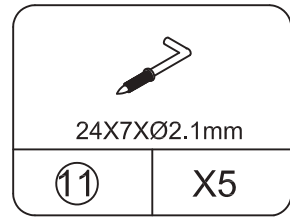
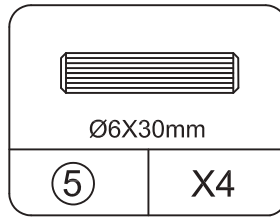
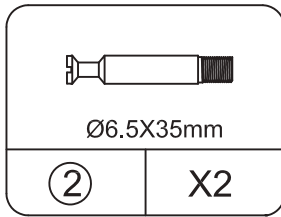
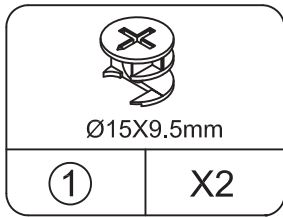

THE RIGHT DIRECTION

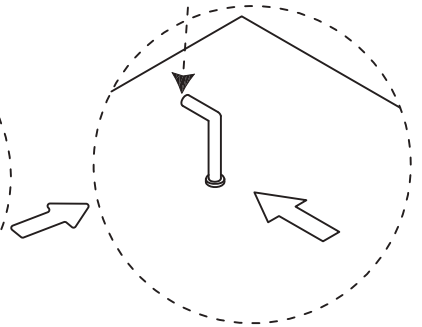
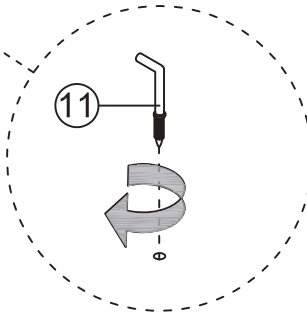
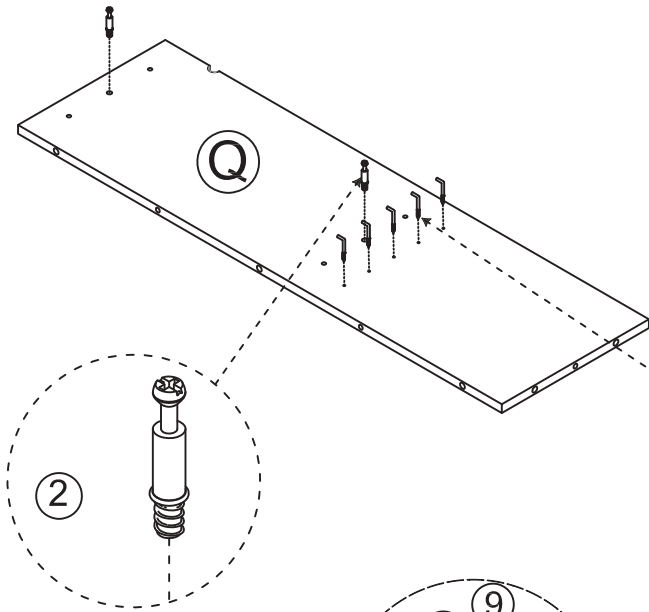

**FINISH**  
No. 11 hardware  
completion direction

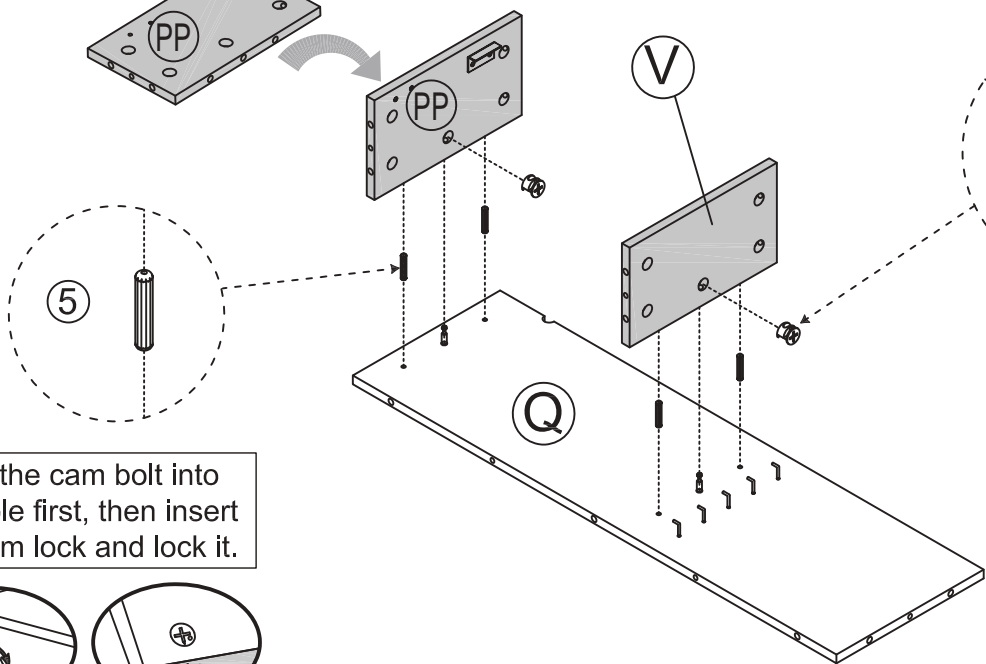
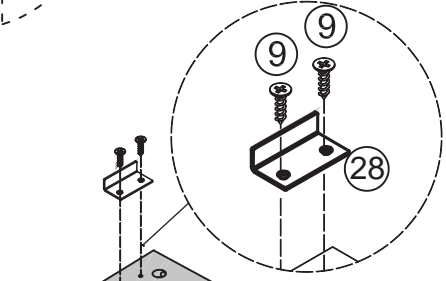

Insert the cam bolt into the hole first, then insert the cam lock and lock it.

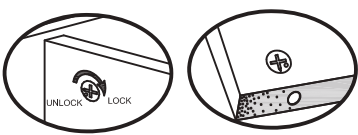

Proper orientation of CAM LOCK

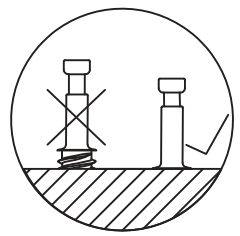

# STEP 7

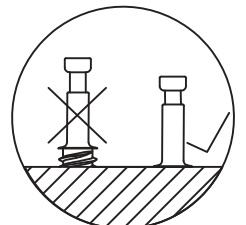
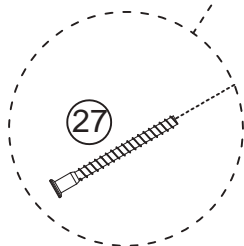
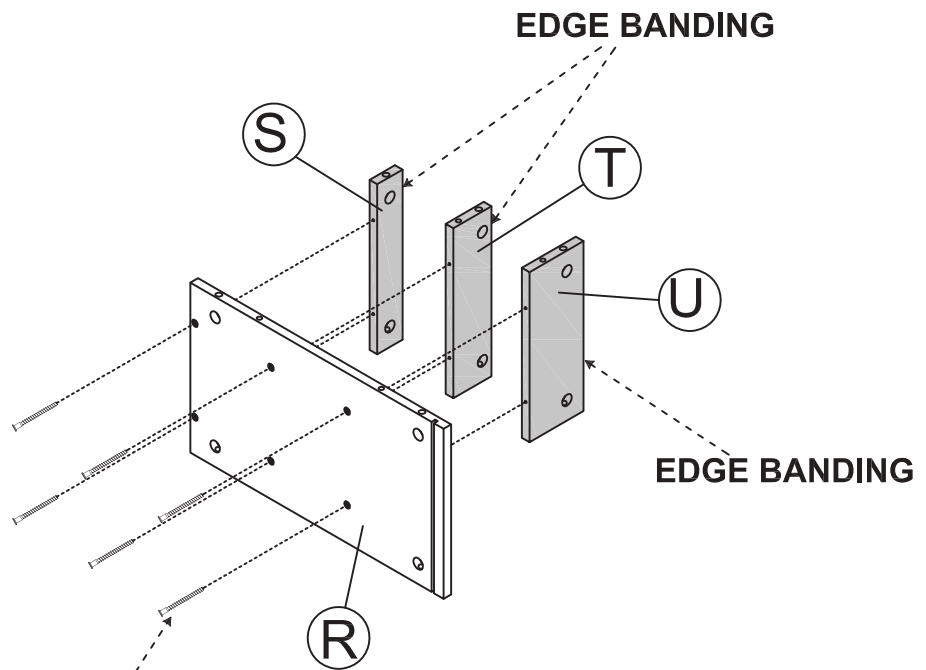
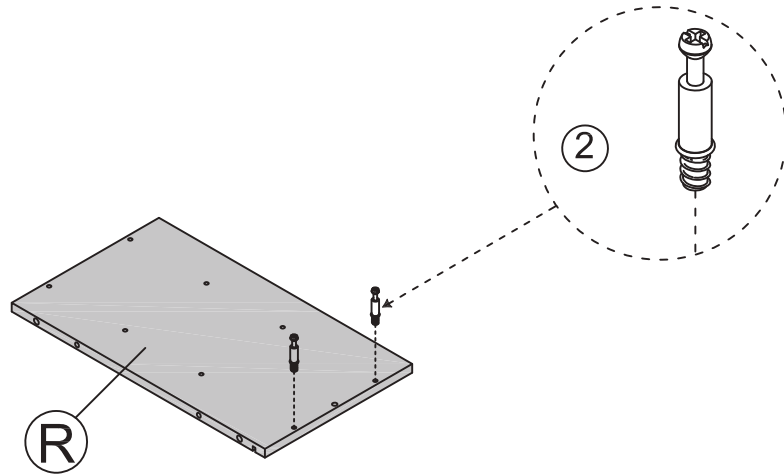
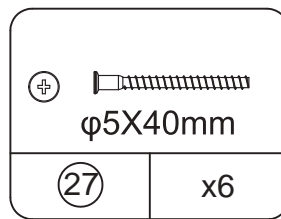
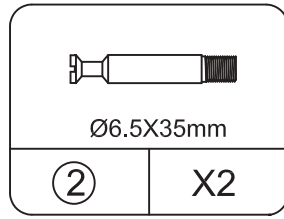

# STEP 8

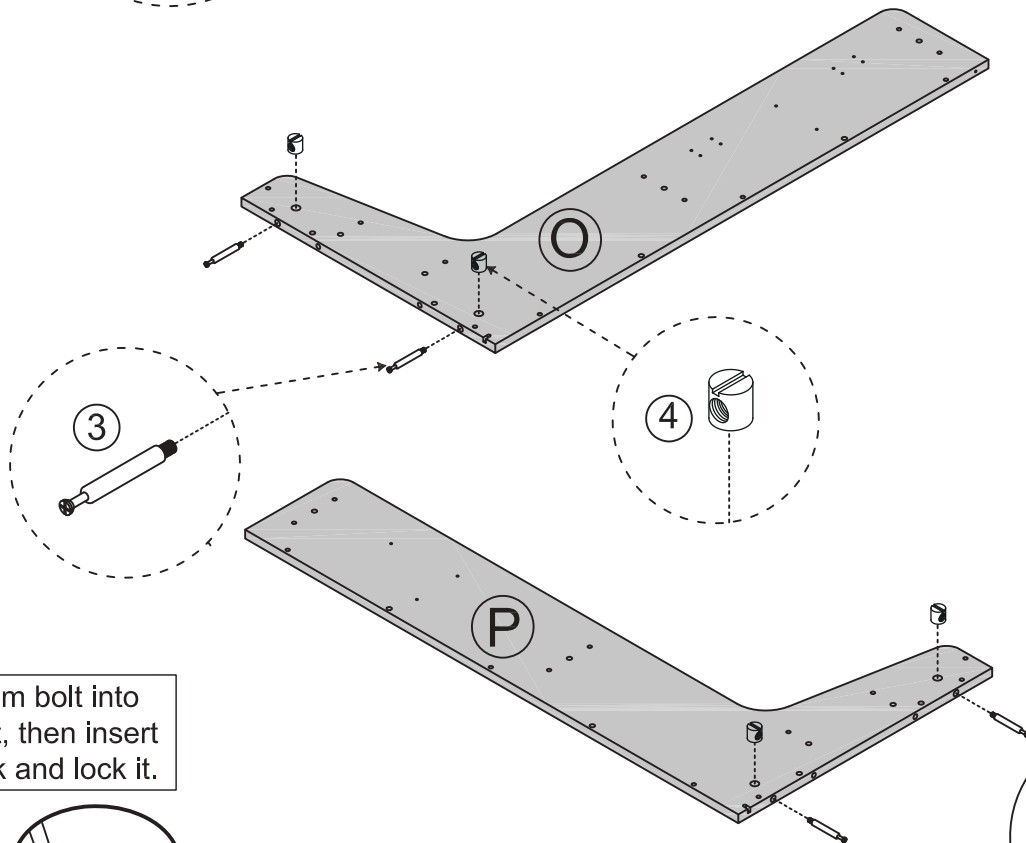
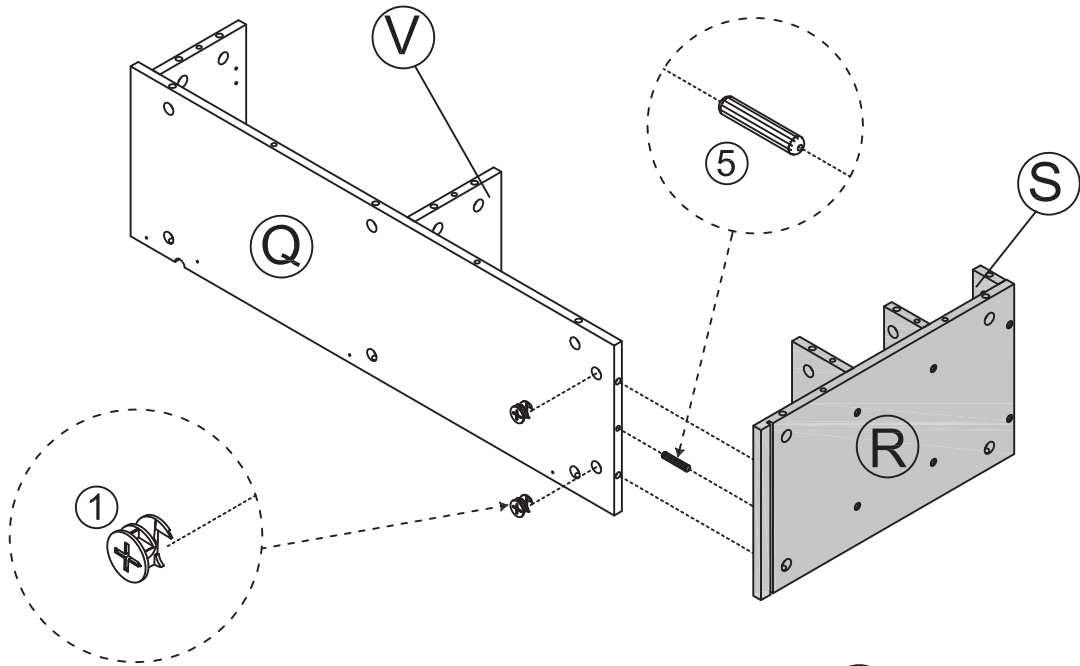
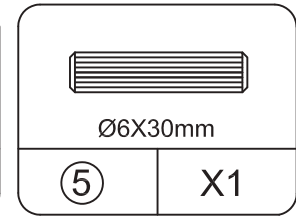
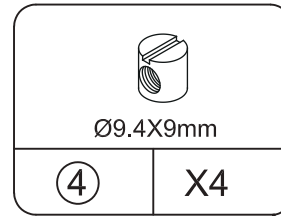
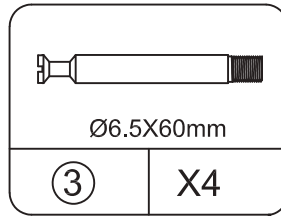
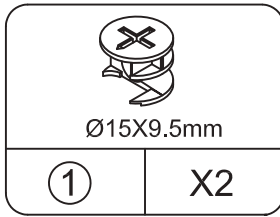

Insert the cam bolt into the hole first, then insert the cam lock and lock it.

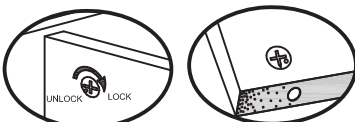

Proper orientation of CAM LOCK

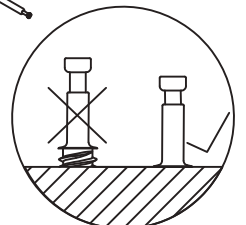

# STEP 9

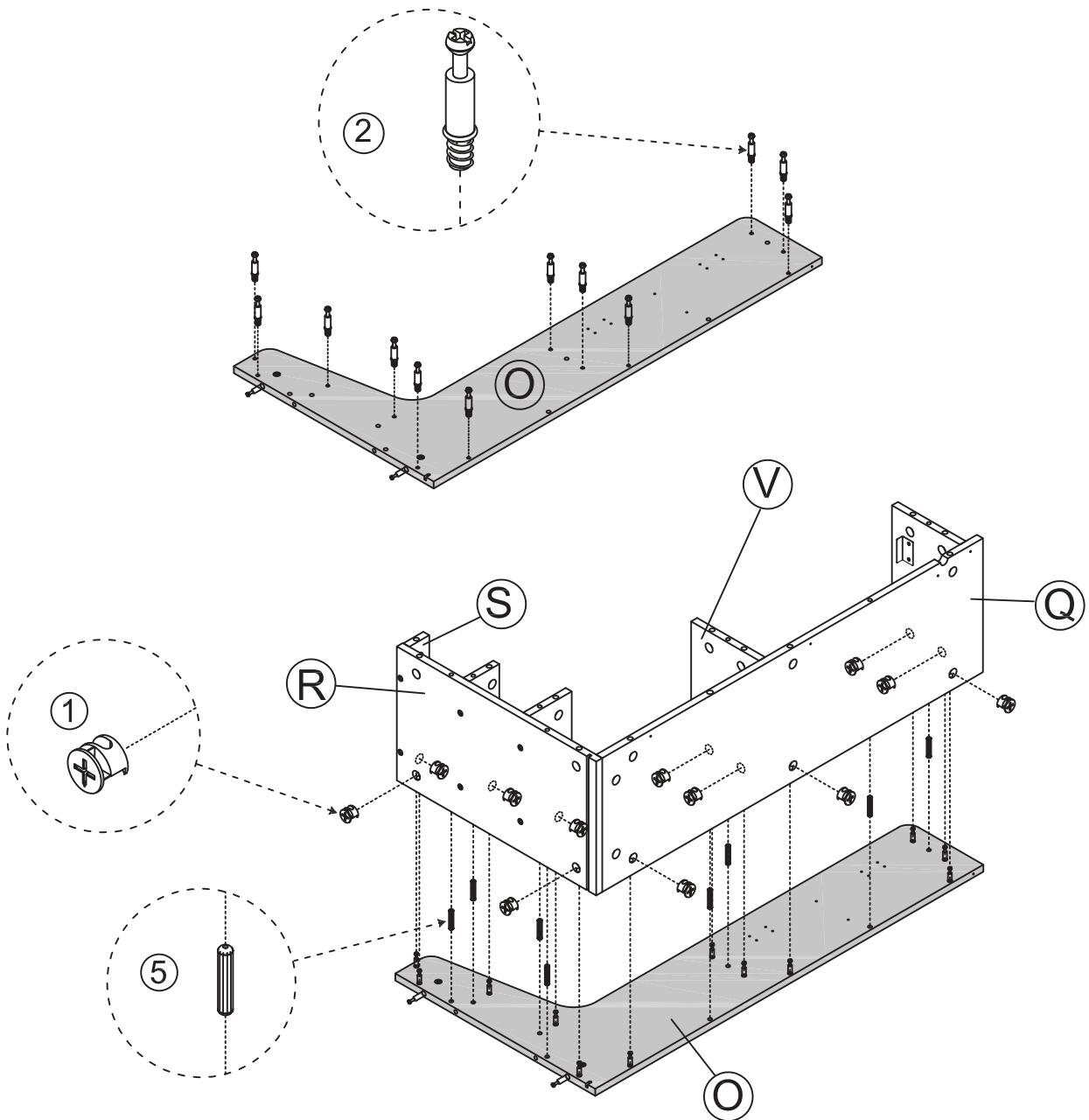
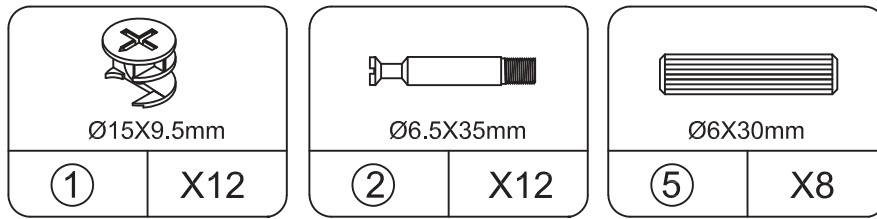

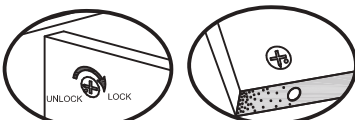

Insert the cam bolt into the hole first, then insert the cam lock and lock it.

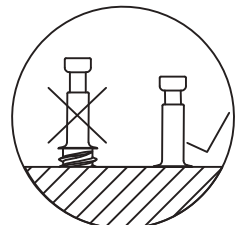

Proper orientation of CAM LOCK



# STEP10

 Ø15X9.5mm	 Ø6.5X35mm	 Ø6X30mm
① X12	② X14	⑤ X8

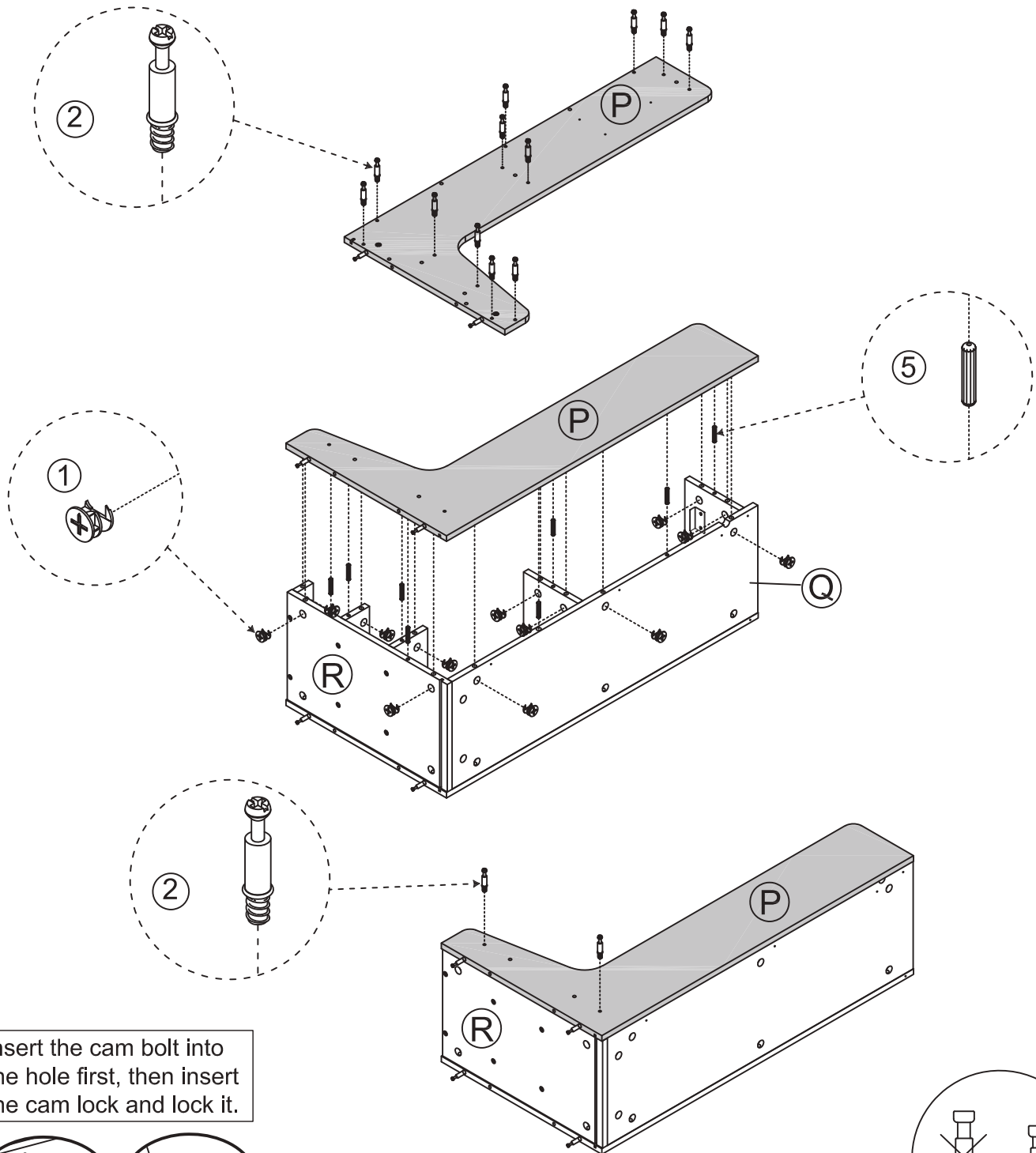

Insert the cam bolt into the hole first, then insert the cam lock and lock it.

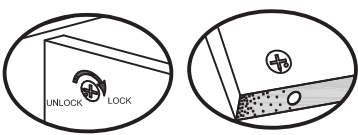

Proper orientation of CAM LOCK

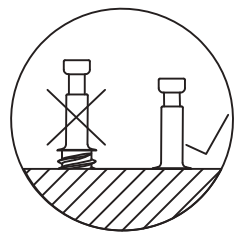

# STEP11

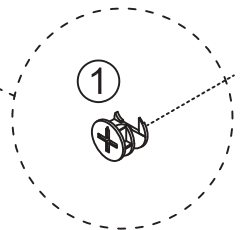
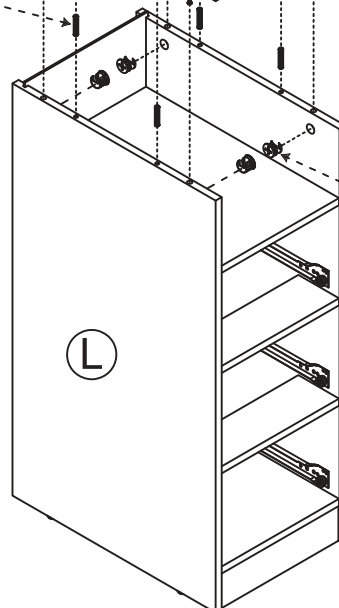
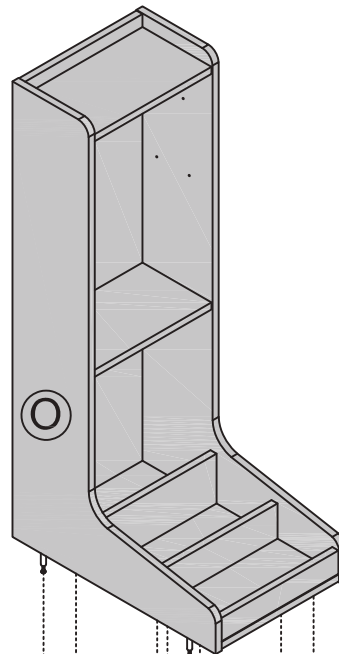
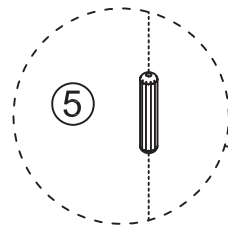
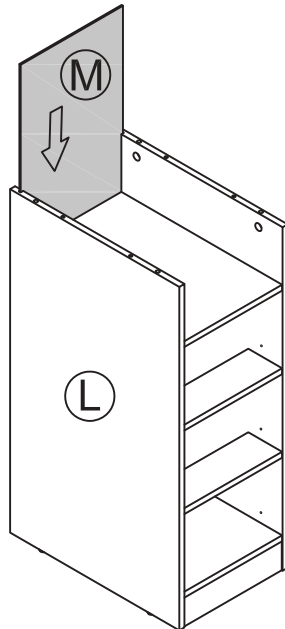
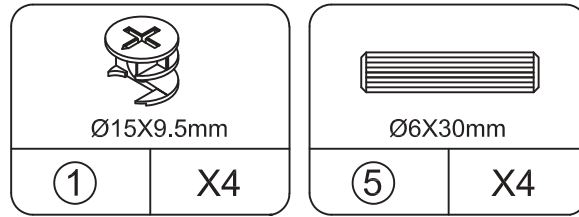

Insert the cam bolt into the hole first, then insert the cam lock and lock it.

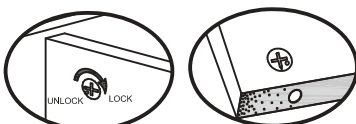

Proper orientation of CAM LOCK

# STEP12

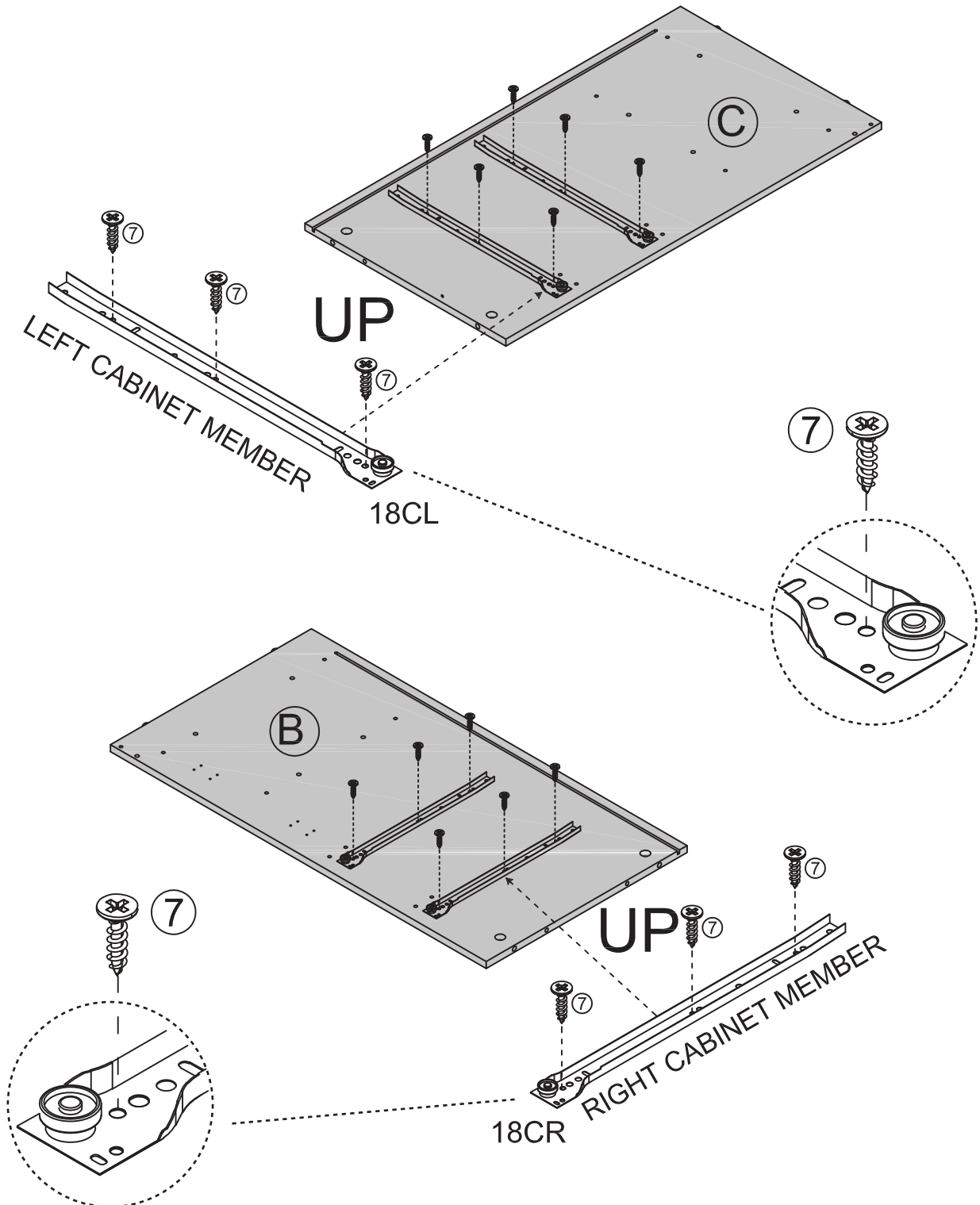
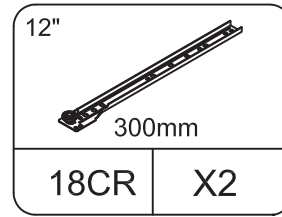
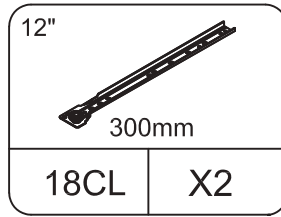
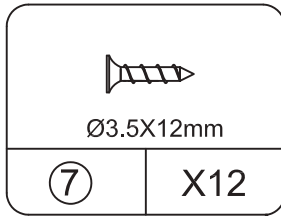

# STEP13

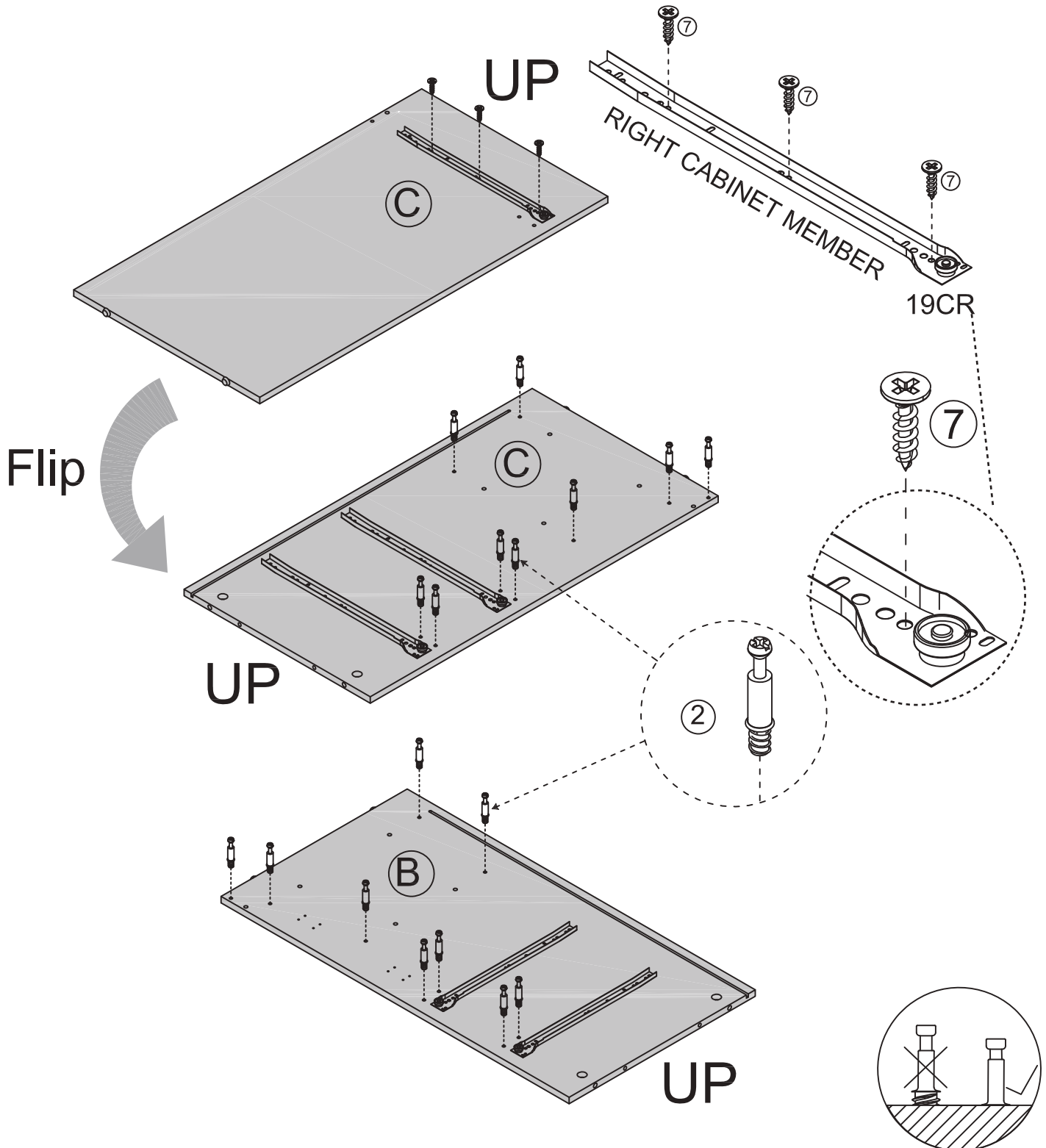
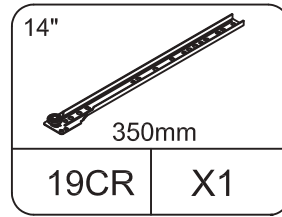
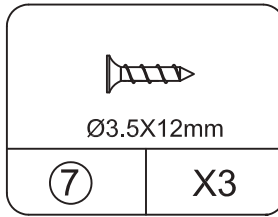
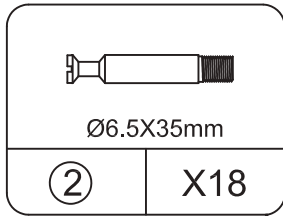

# STEP14

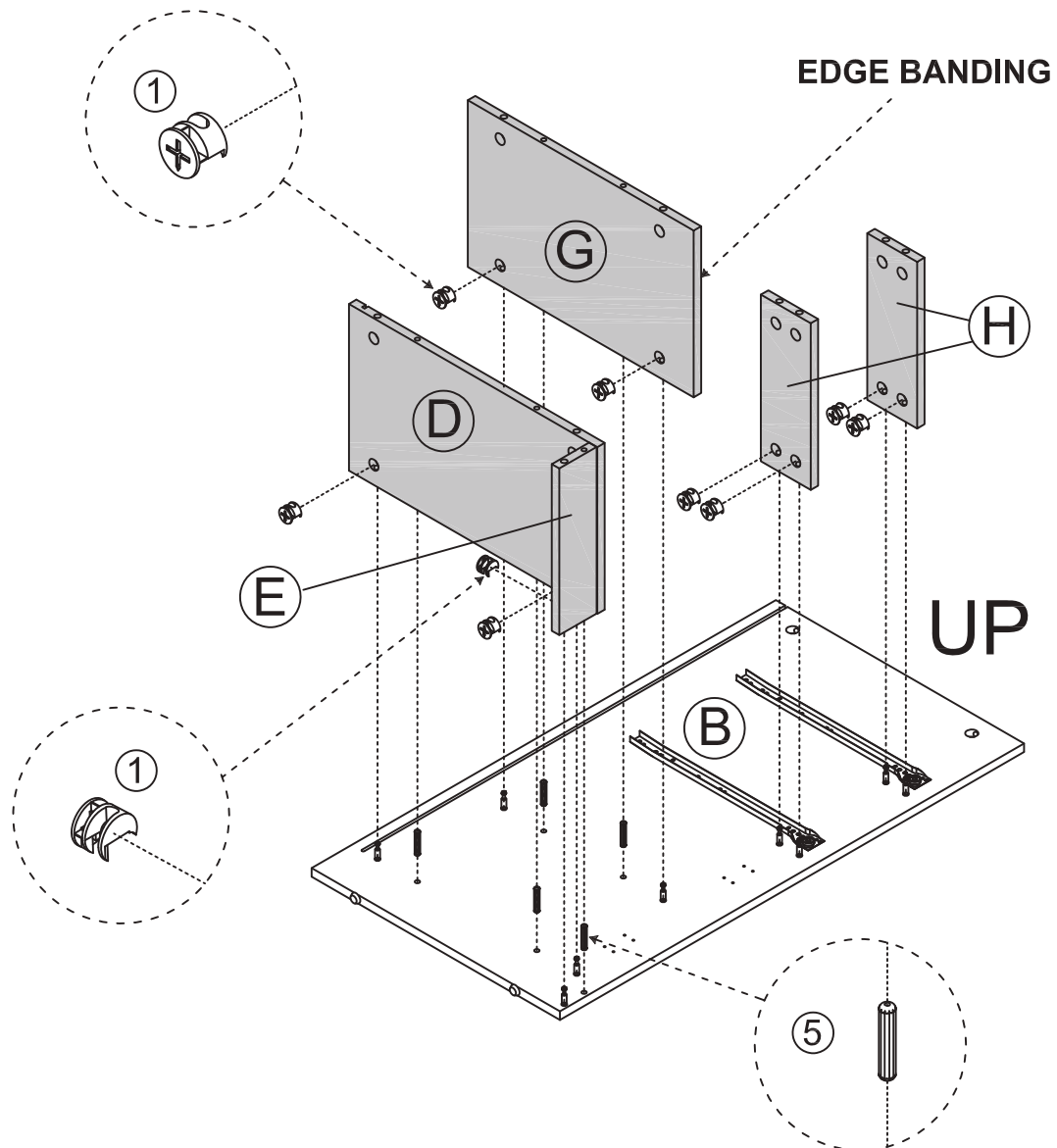
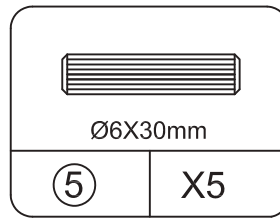
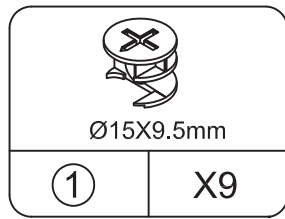

Insert the cam bolt into the hole first, then insert the cam lock and lock it.

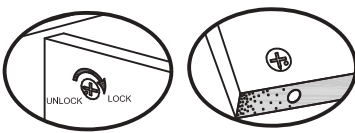

Proper orientation of CAM LOCK

# STEP15

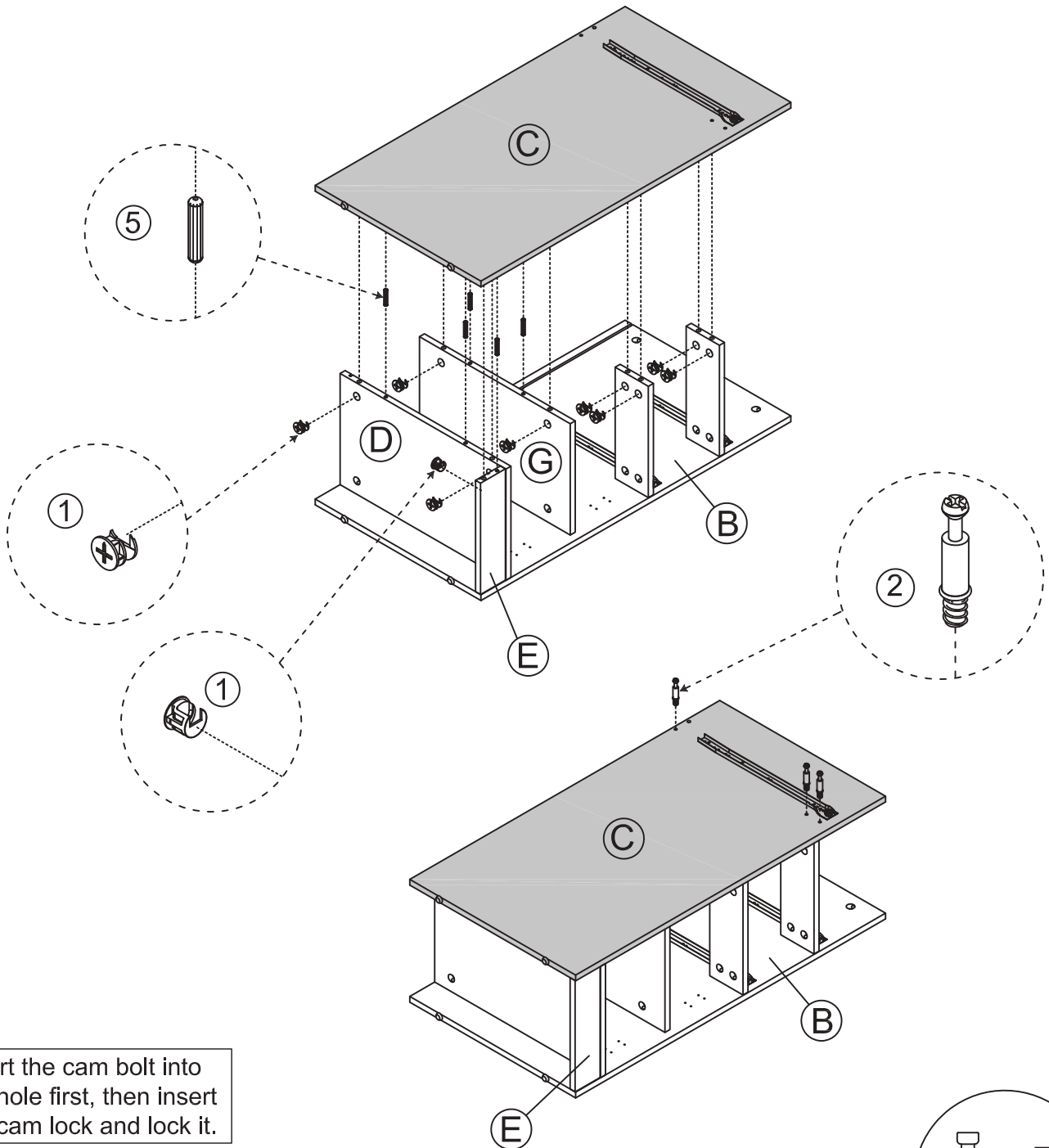
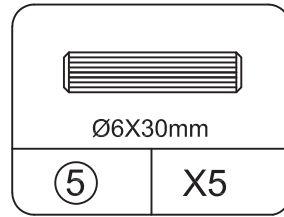
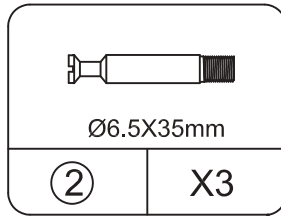
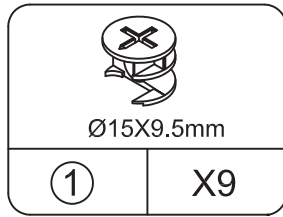

Insert the cam bolt into the hole first, then insert the cam lock and lock it.

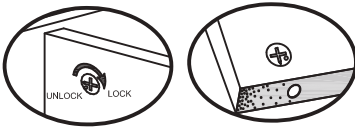

Proper orientation of CAM LOCK

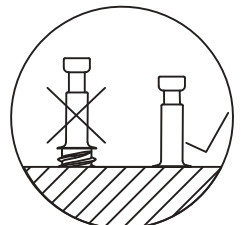

# STEP16

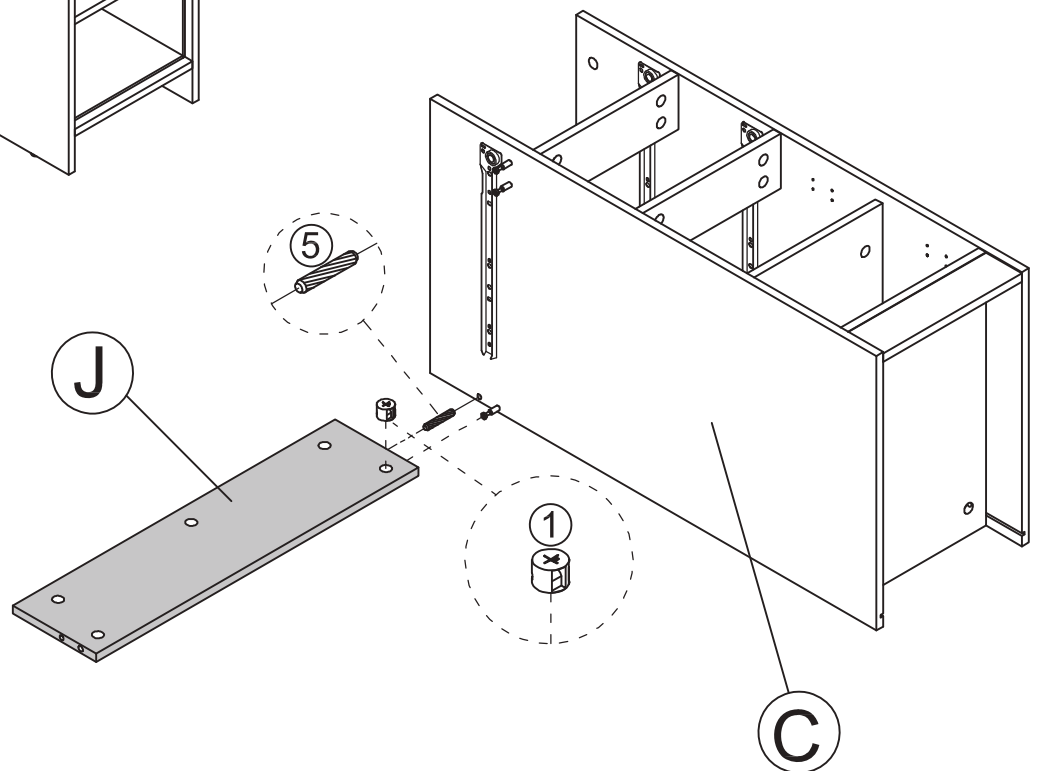
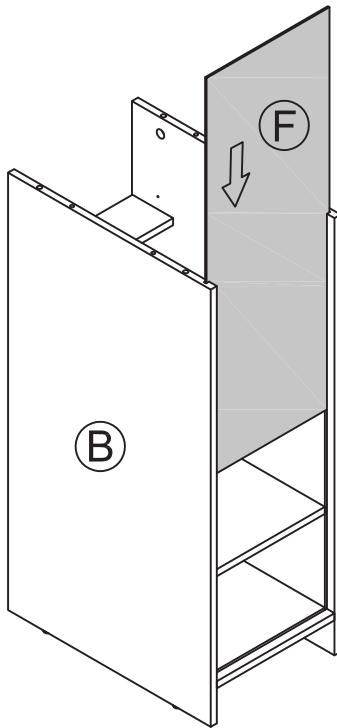
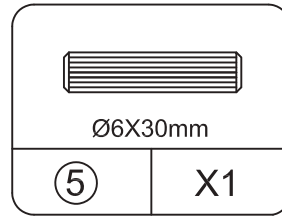
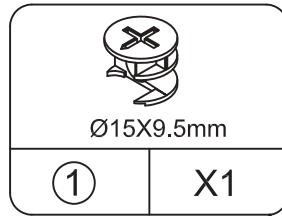

Insert the cam bolt into the hole first, then insert the cam lock and lock it.

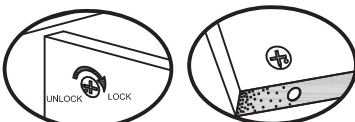

Proper orientation of CAM LOCK

# STEP17

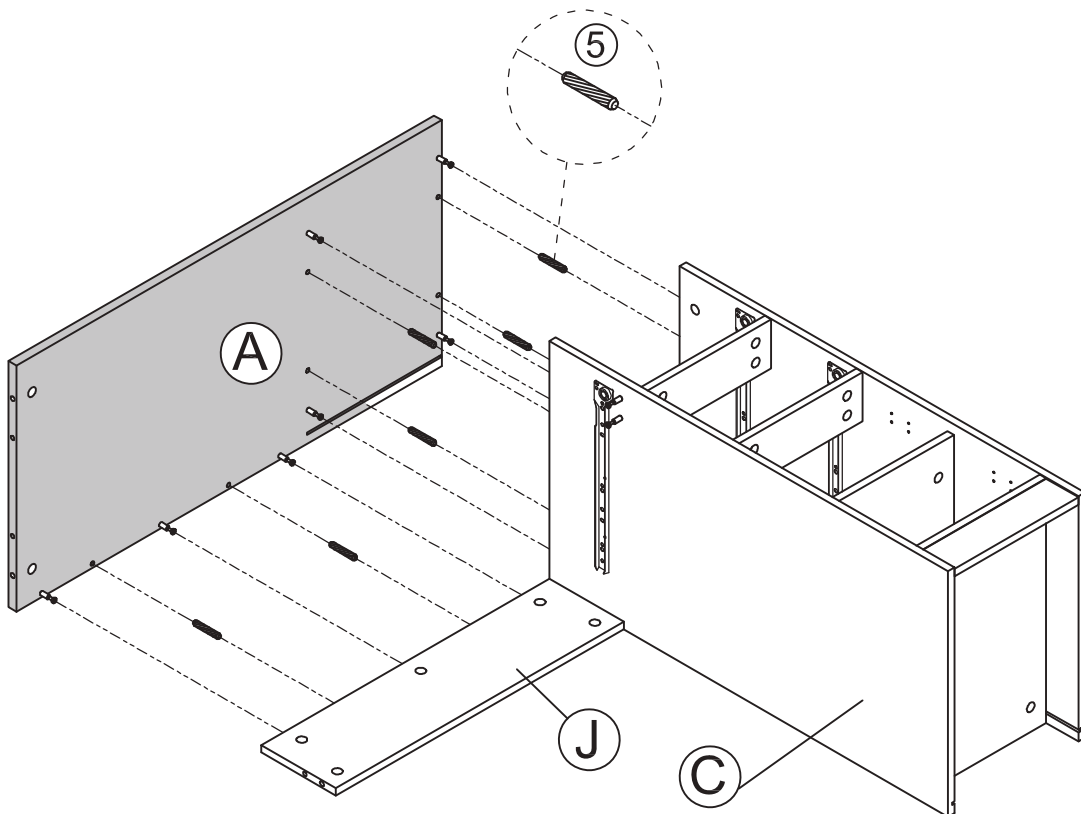
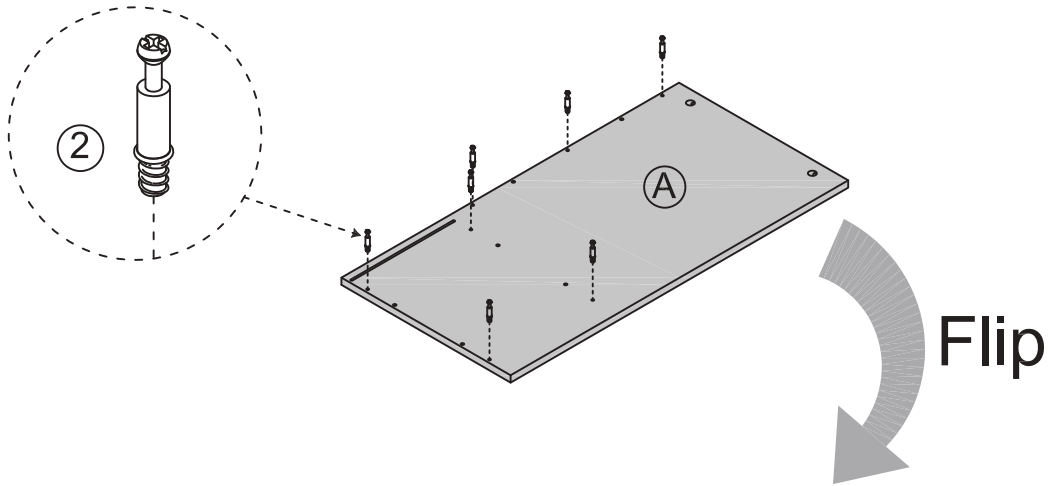
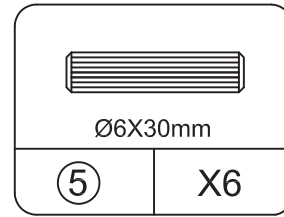
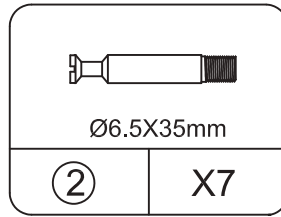

Insert the cam bolt into the hole first, then insert the cam lock and lock it.



Proper orientation of CAM LOCK

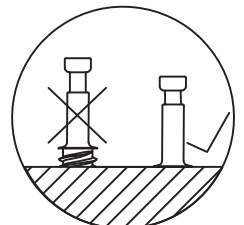

# STEP18

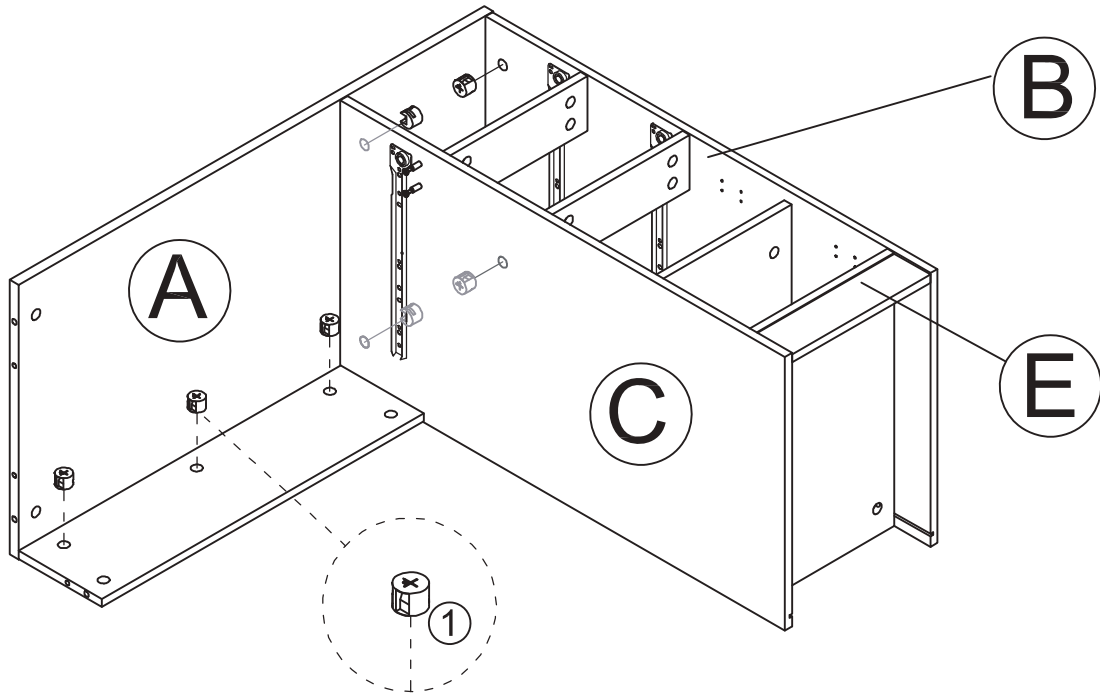
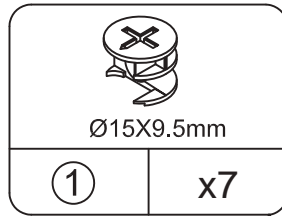

Insert the cam bolt into the hole first, then insert the cam lock and lock it.

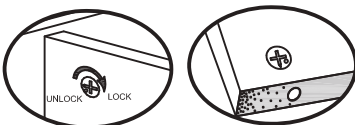

Proper orientation of CAM LOCK

# STEP19

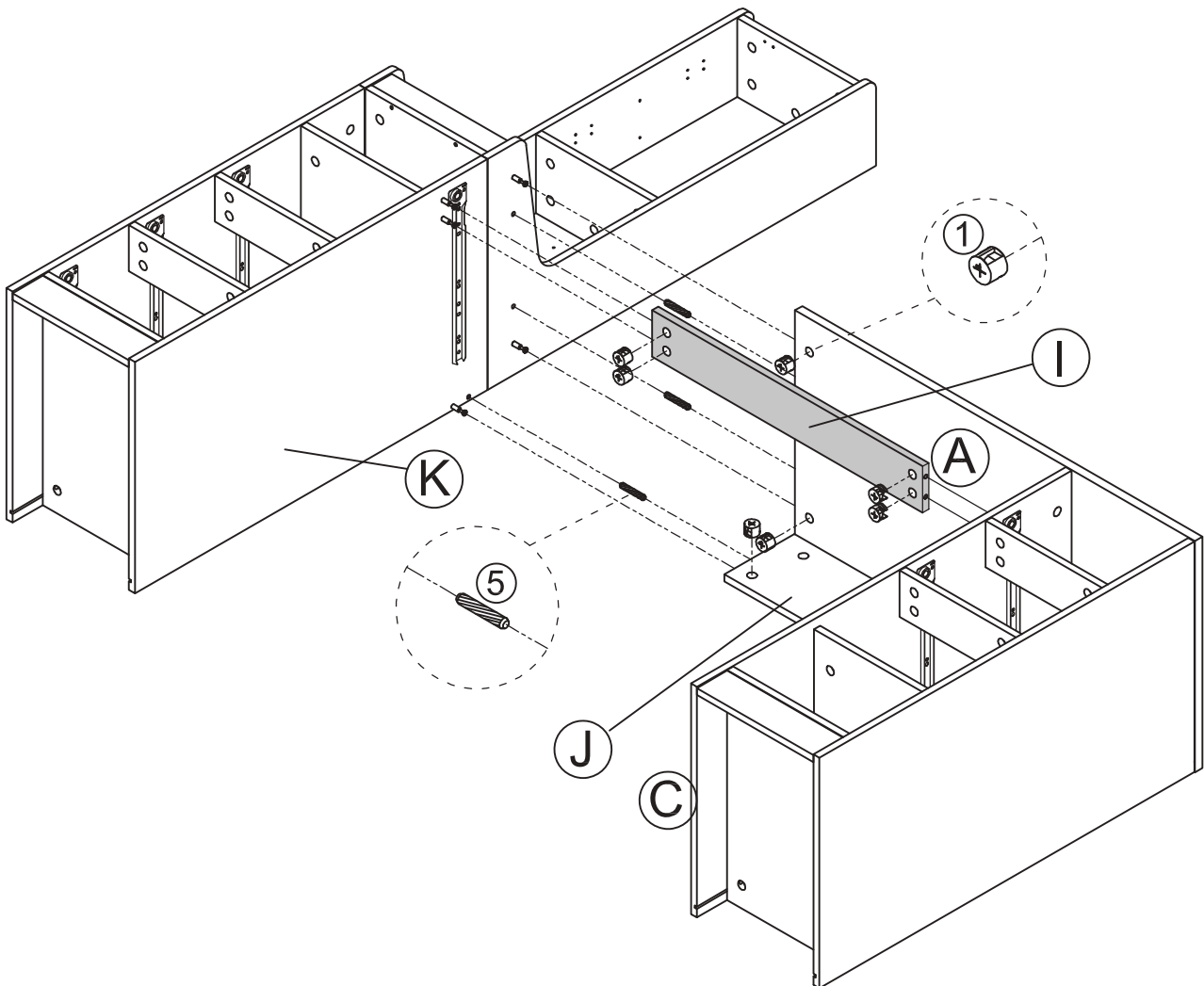
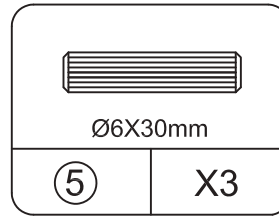
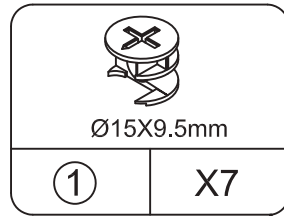

Insert the cam bolt into the hole first, then insert the cam lock and lock it.



Proper orientation of CAM LOCK

# STEP20



Ø15X9.5mm

①	X2
---	----

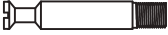

Ø6.5X35mm

②	X2
---	----



Ø6X30mm

⑤	X4
---	----

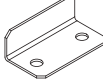

②⑧	x1
----	----



Ø3X12mm

⑨	x2
---	----

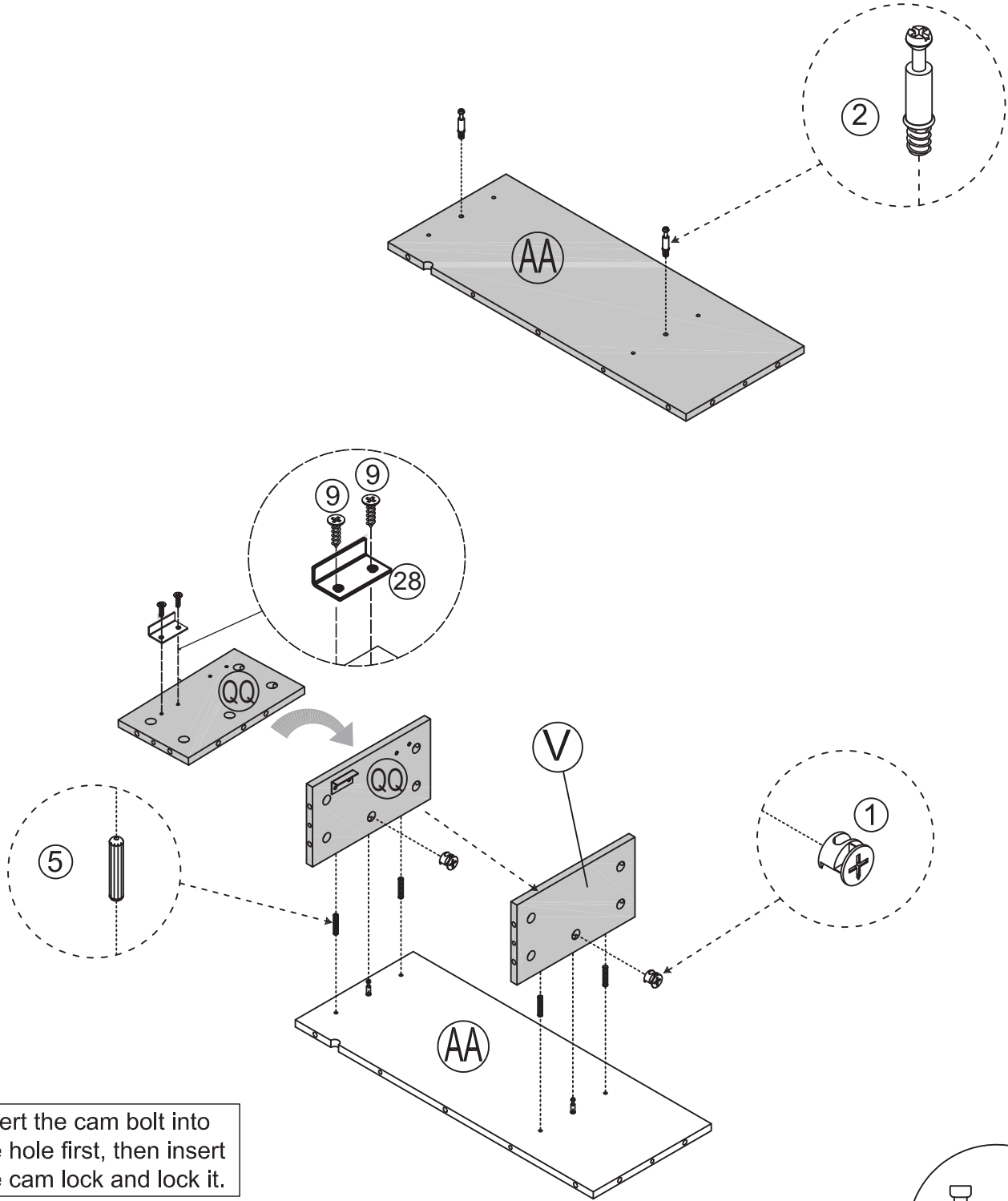

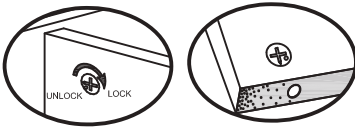

Insert the cam bolt into the hole first, then insert the cam lock and lock it.

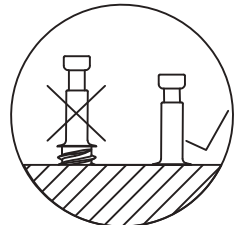

Proper orientation of CAM LOCK

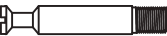

# STEP21

 Ø15X9.5mm	 Ø6.5X35mm	 Ø6X30mm
① X2	② X2	⑤ X1

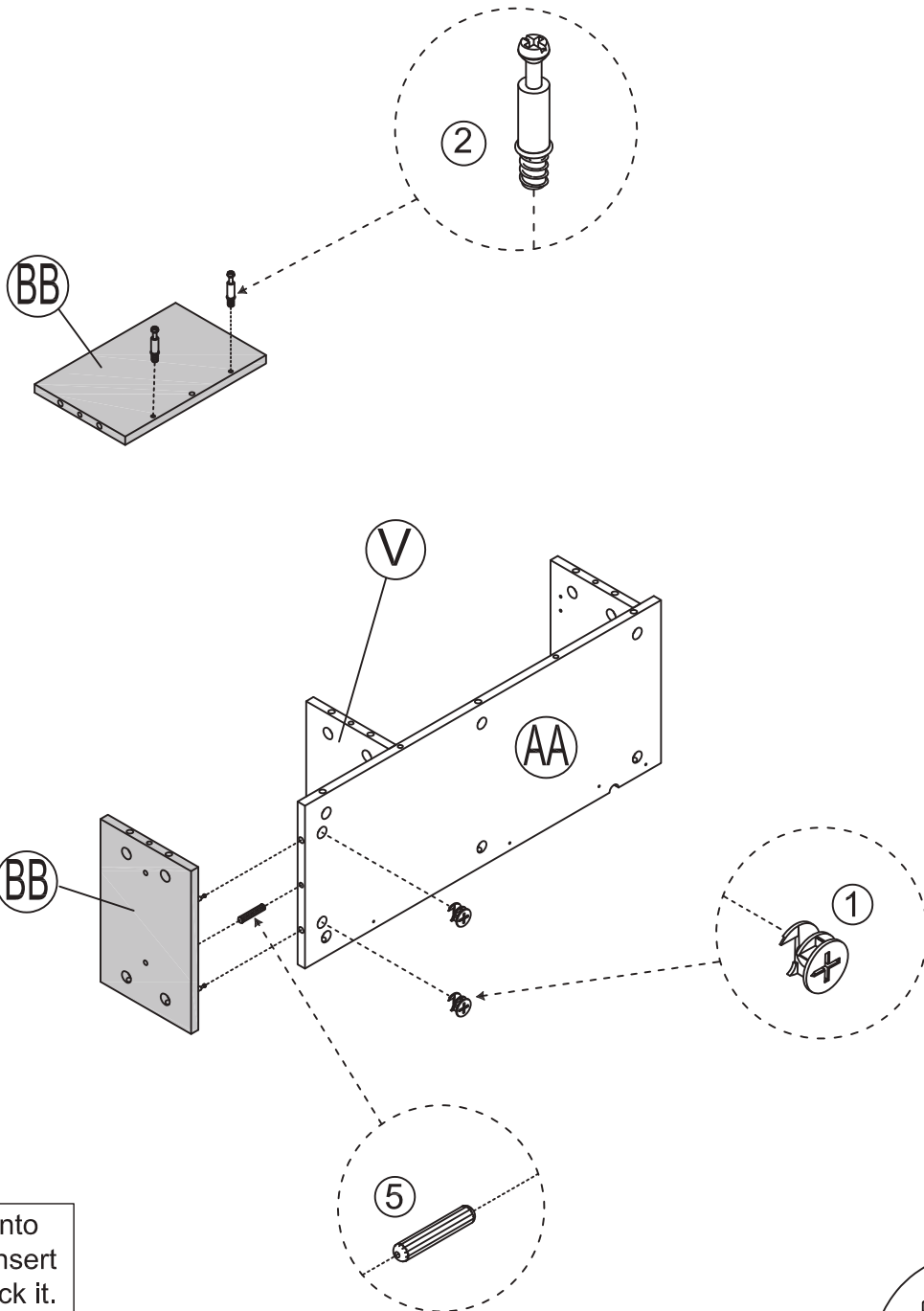

Insert the cam bolt into the hole first, then insert the cam lock and lock it.

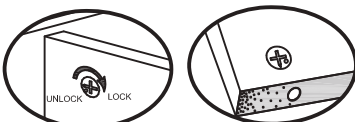

Proper orientation of CAM LOCK

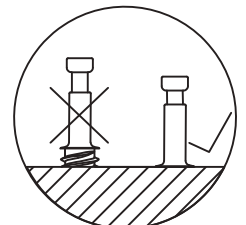

# STEP22

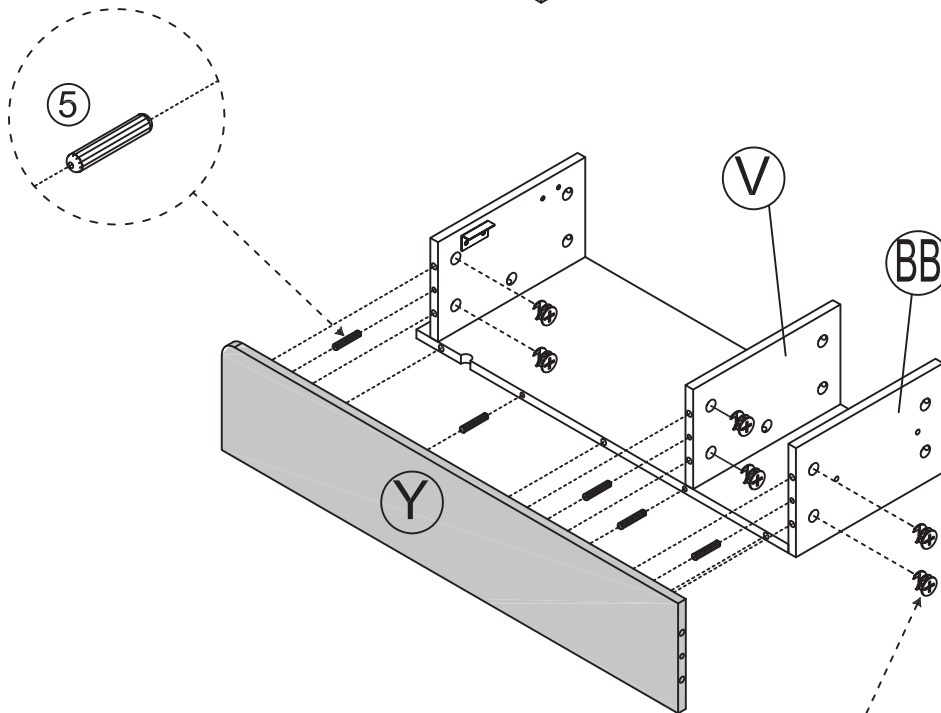
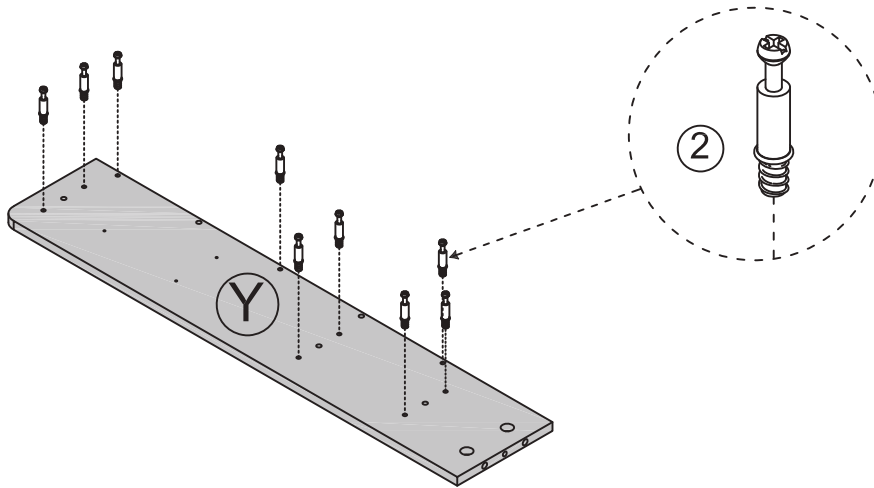
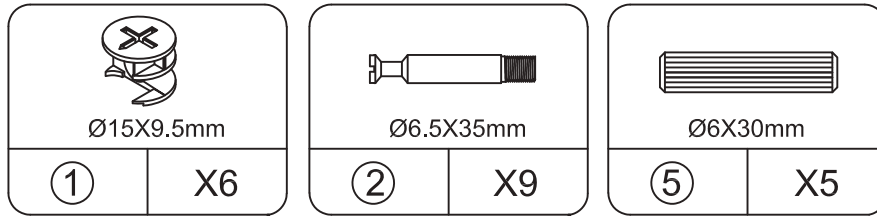

Insert the cam bolt into the hole first, then insert the cam lock and lock it.



Proper orientation of CAM LOCK

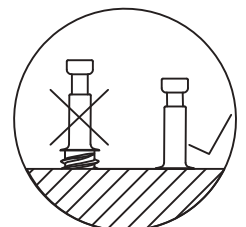
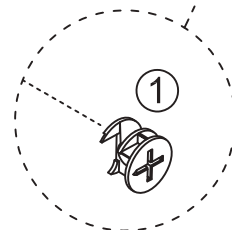

# STEP23

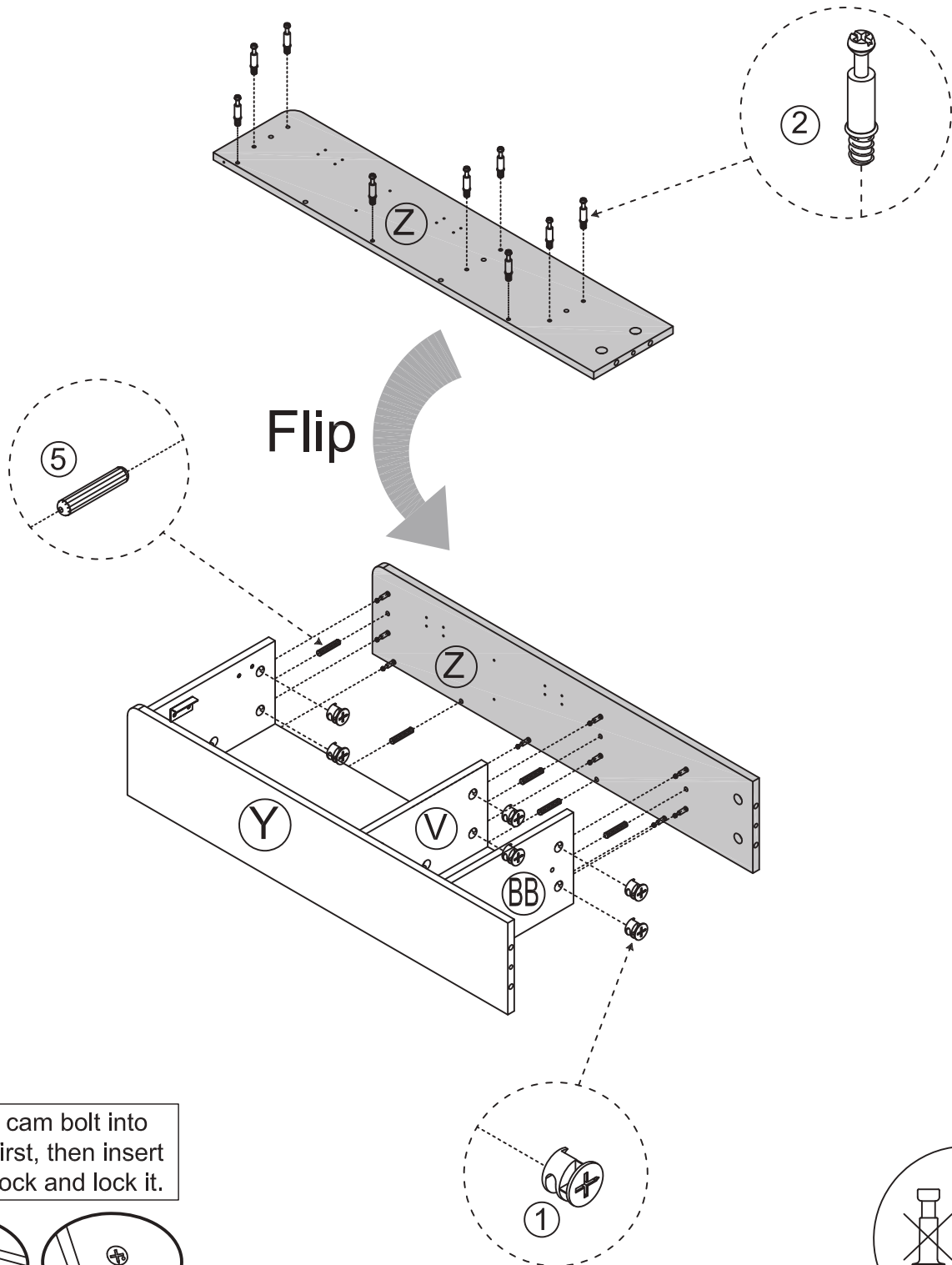
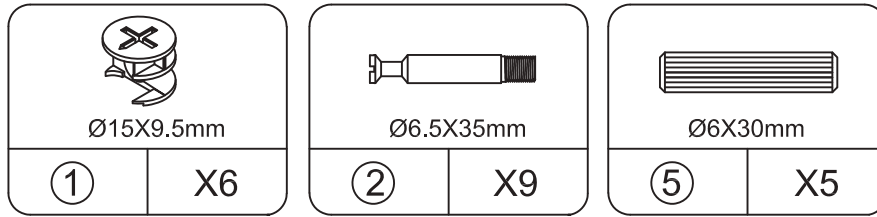

Insert the cam bolt into the hole first, then insert the cam lock and lock it.

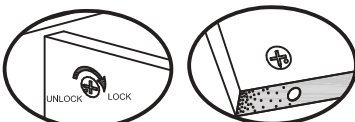

Proper orientation of CAM LOCK

# STEP24

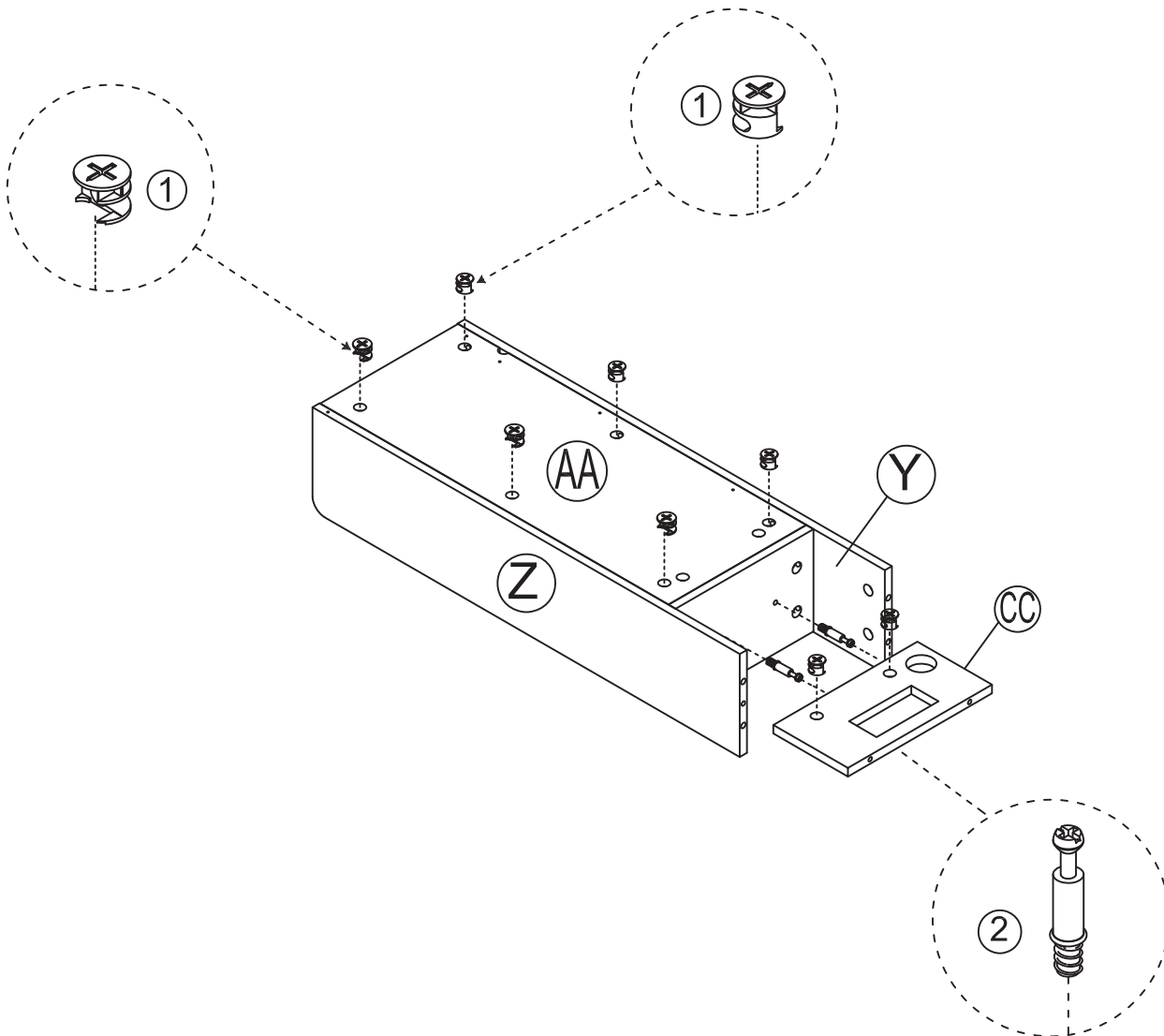
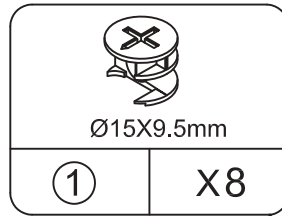
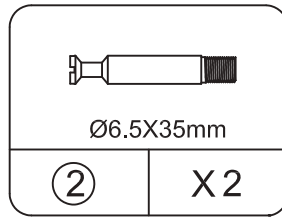

Insert the cam bolt into the hole first, then insert the cam lock and lock it.

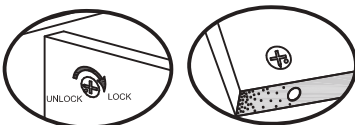

Proper orientation of CAM LOCK

# STEP25

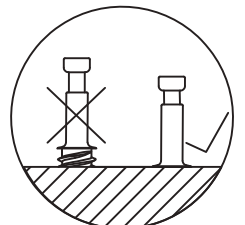
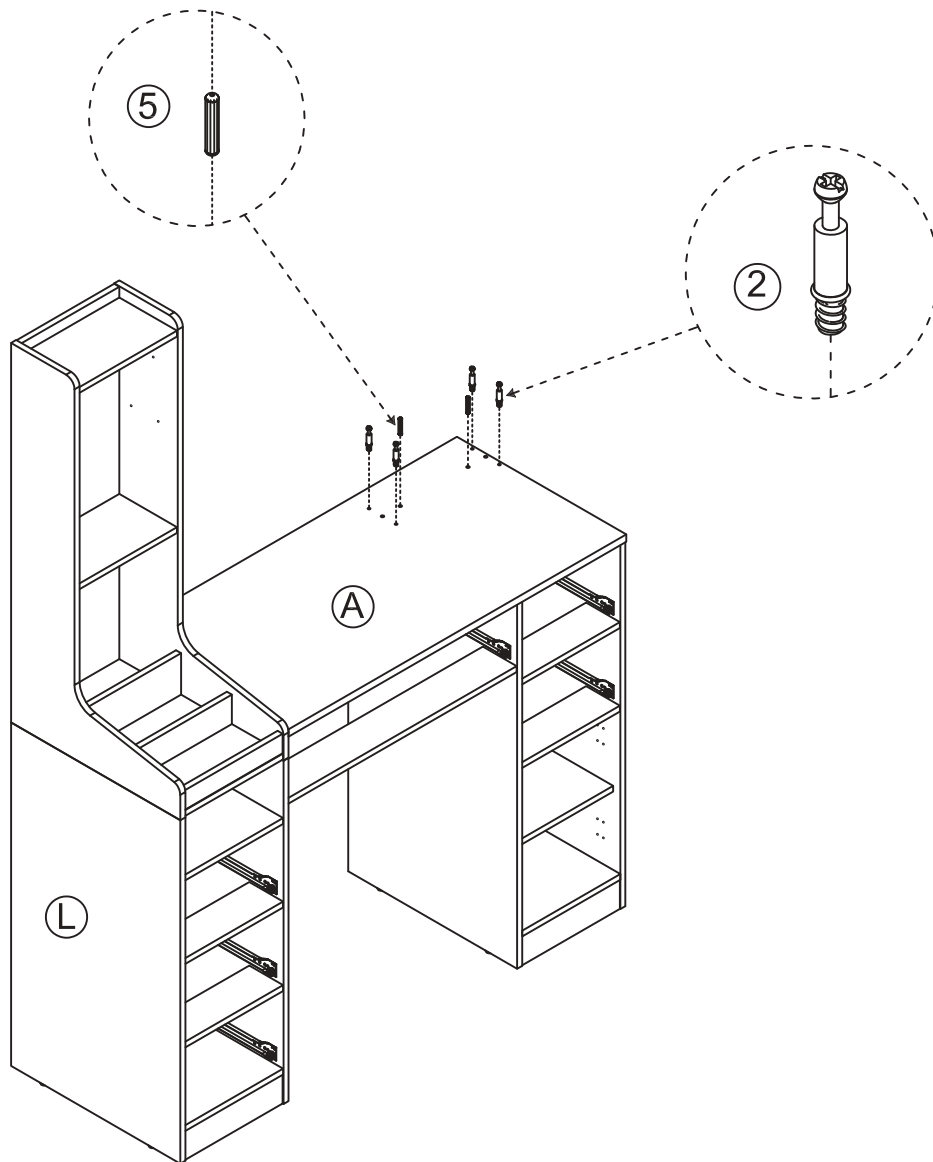
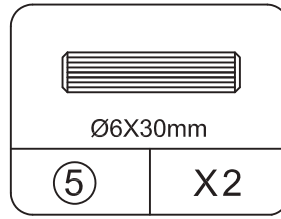
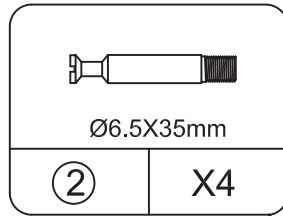

# STEP26

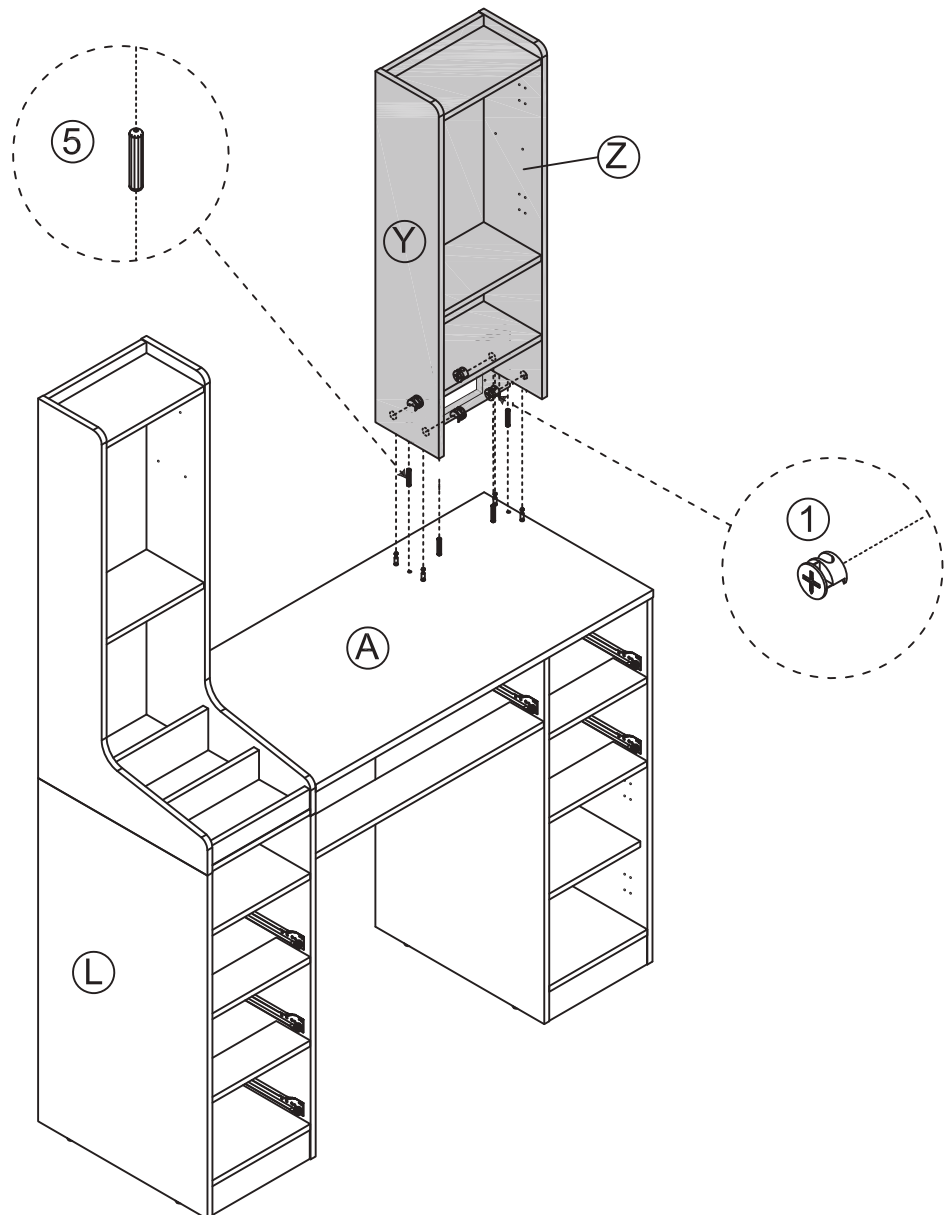
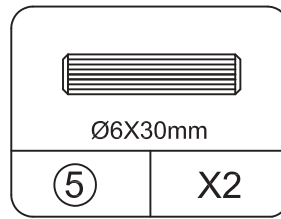
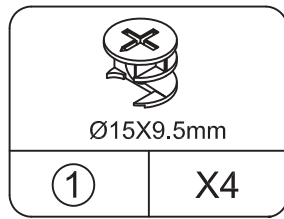

Insert the cam bolt into the hole first, then insert the cam lock and lock it.

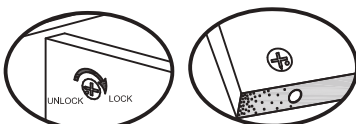

Proper orientation of CAM LOCK

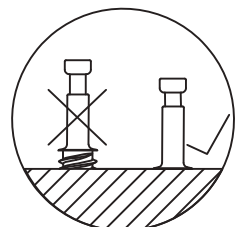

# STEP27

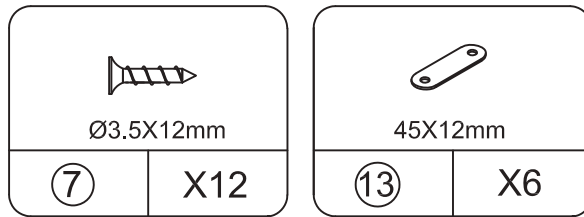

When installing accessories,  
you need to move closer to the middle

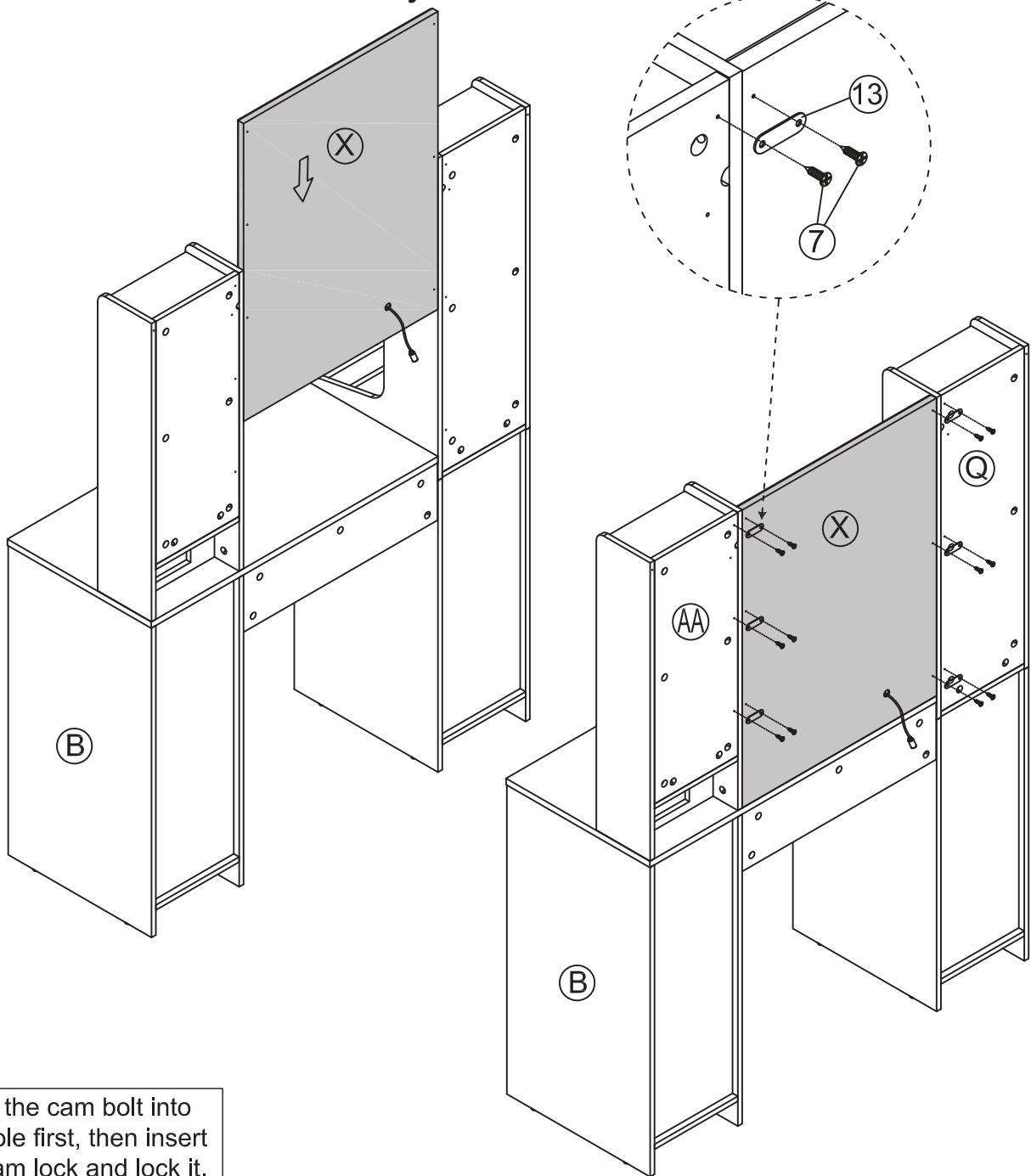

Insert the cam bolt into  
the hole first, then insert  
the cam lock and lock it.

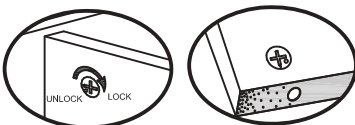

Proper orientation of CAM LOCK

# STEP28

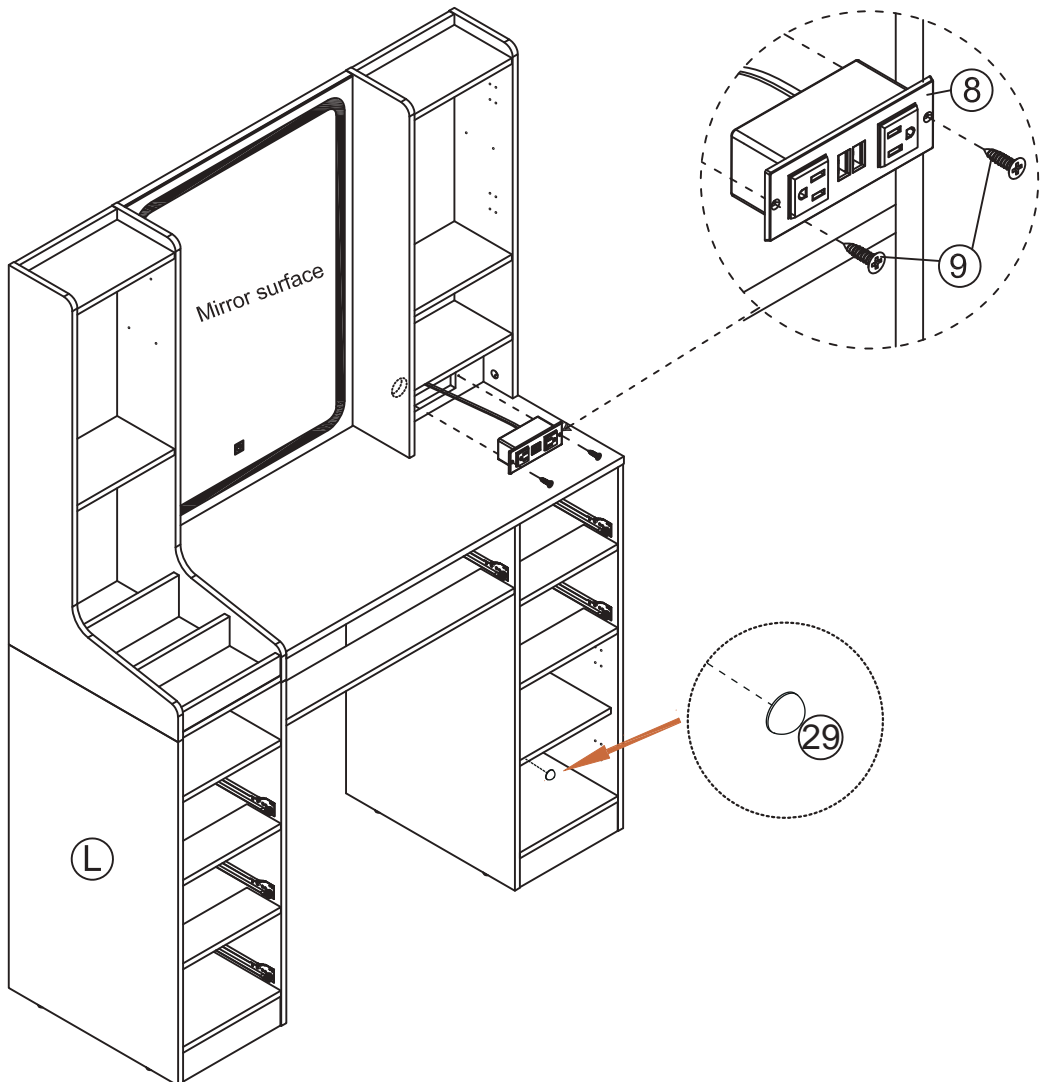
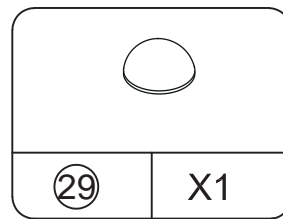
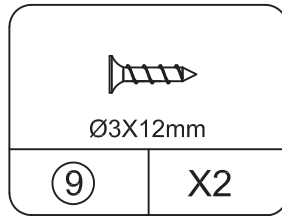
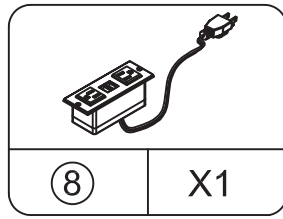

# STEP29

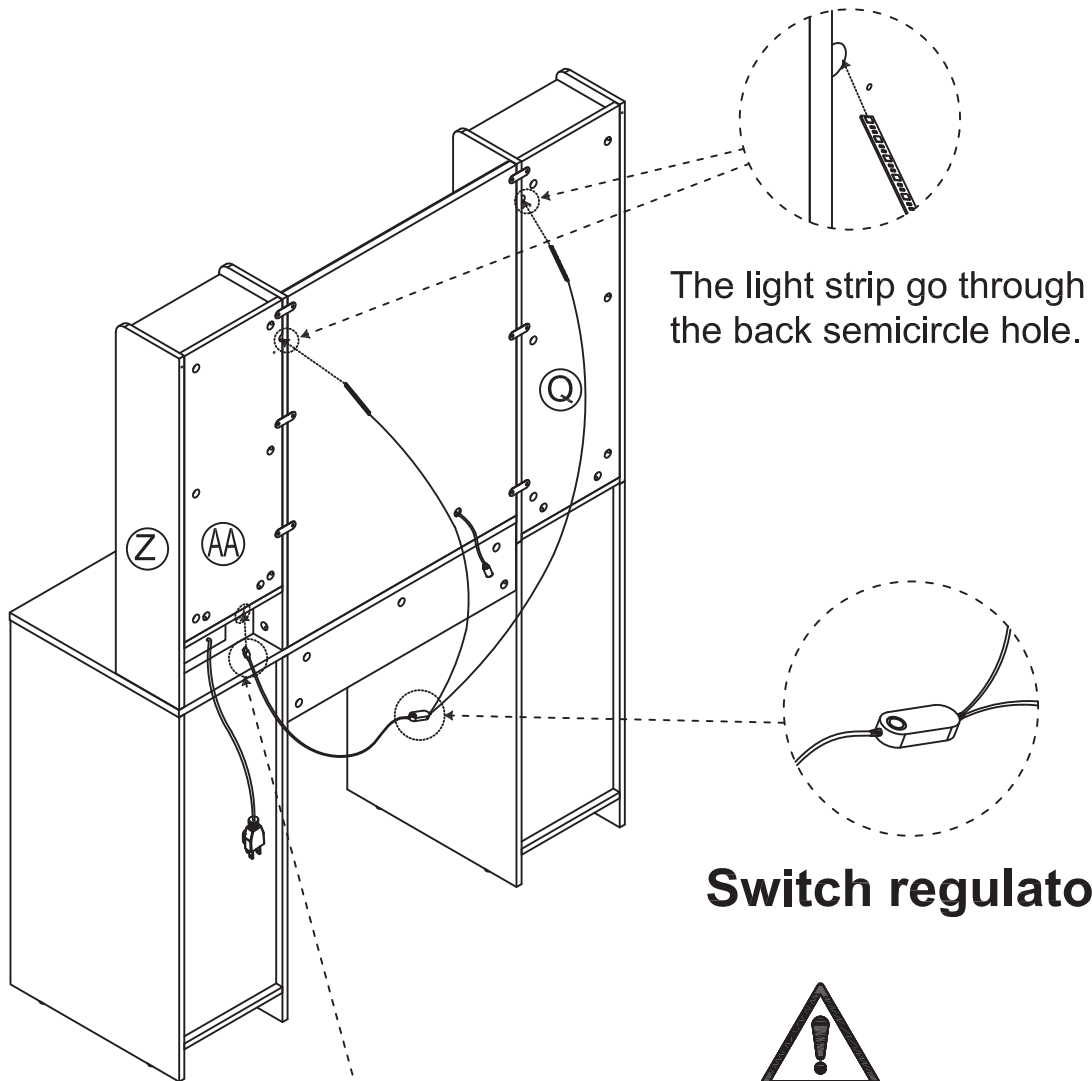
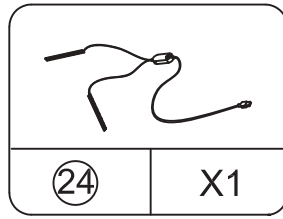

The light strip go through the back semicircle hole.

**Switch regulator**



USB and Switch regulator go through the round hole next to the socket

**USB**

# STEP30

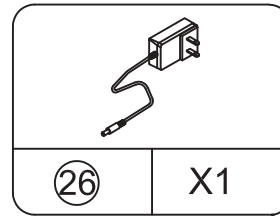
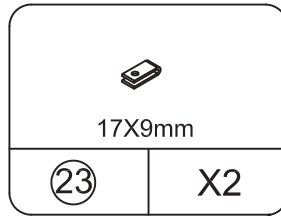
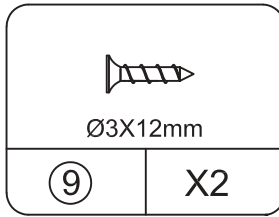



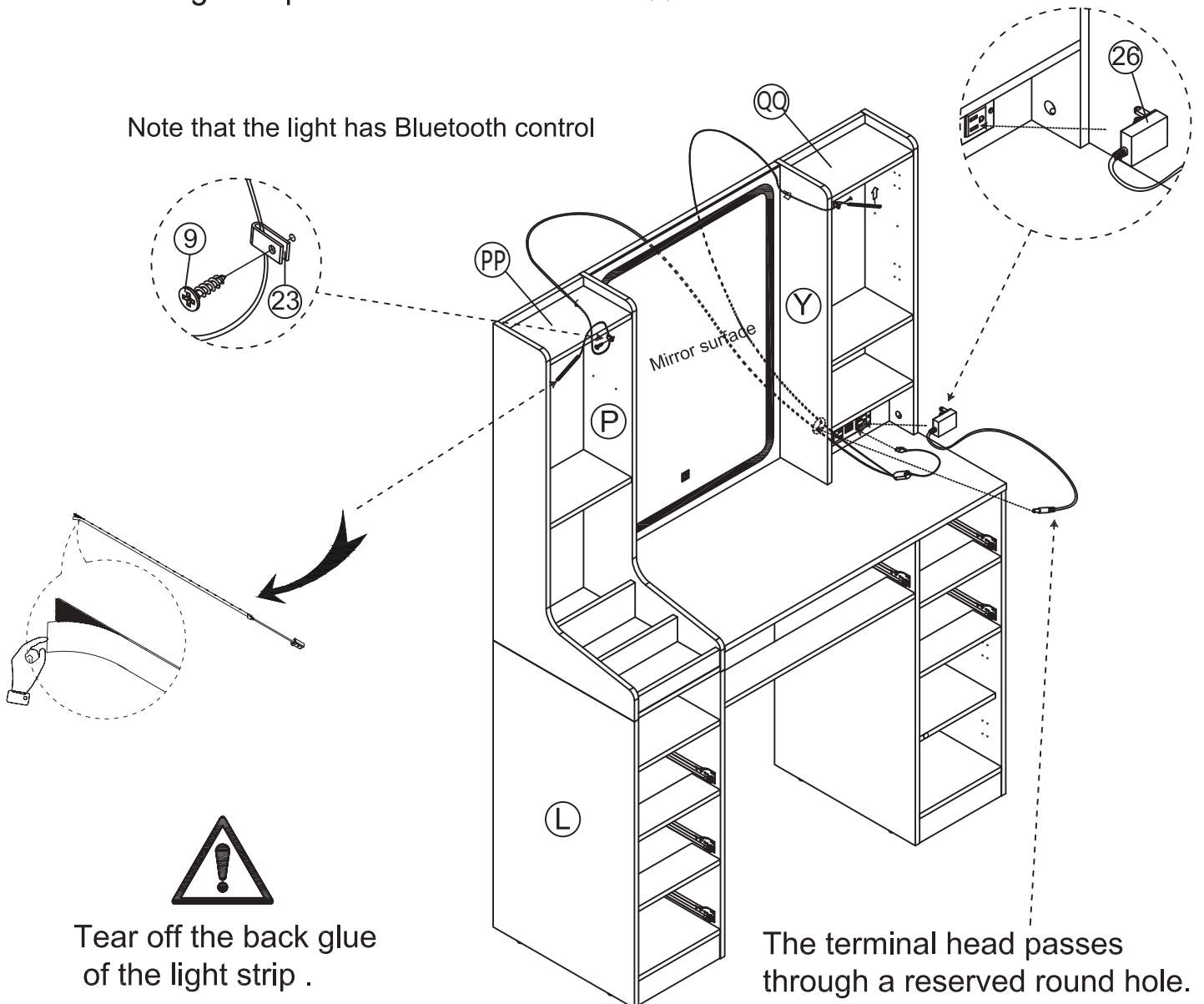

First of all, the lamp belt line is fixed on the P and Y board with the pressure buckle 23#, and then Tear off the back glue of the light strip and stick it on the PP and QQ board.

Note that the light has Bluetooth control

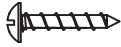

# STEP31

 Ø3X12mm		 17X9mm		 160X20mm		 Ø4X14 mm		 Ø3×14mm	
⑨	X2	⑳	X2	㉑	X2	㉒	X2	㉓	X16set

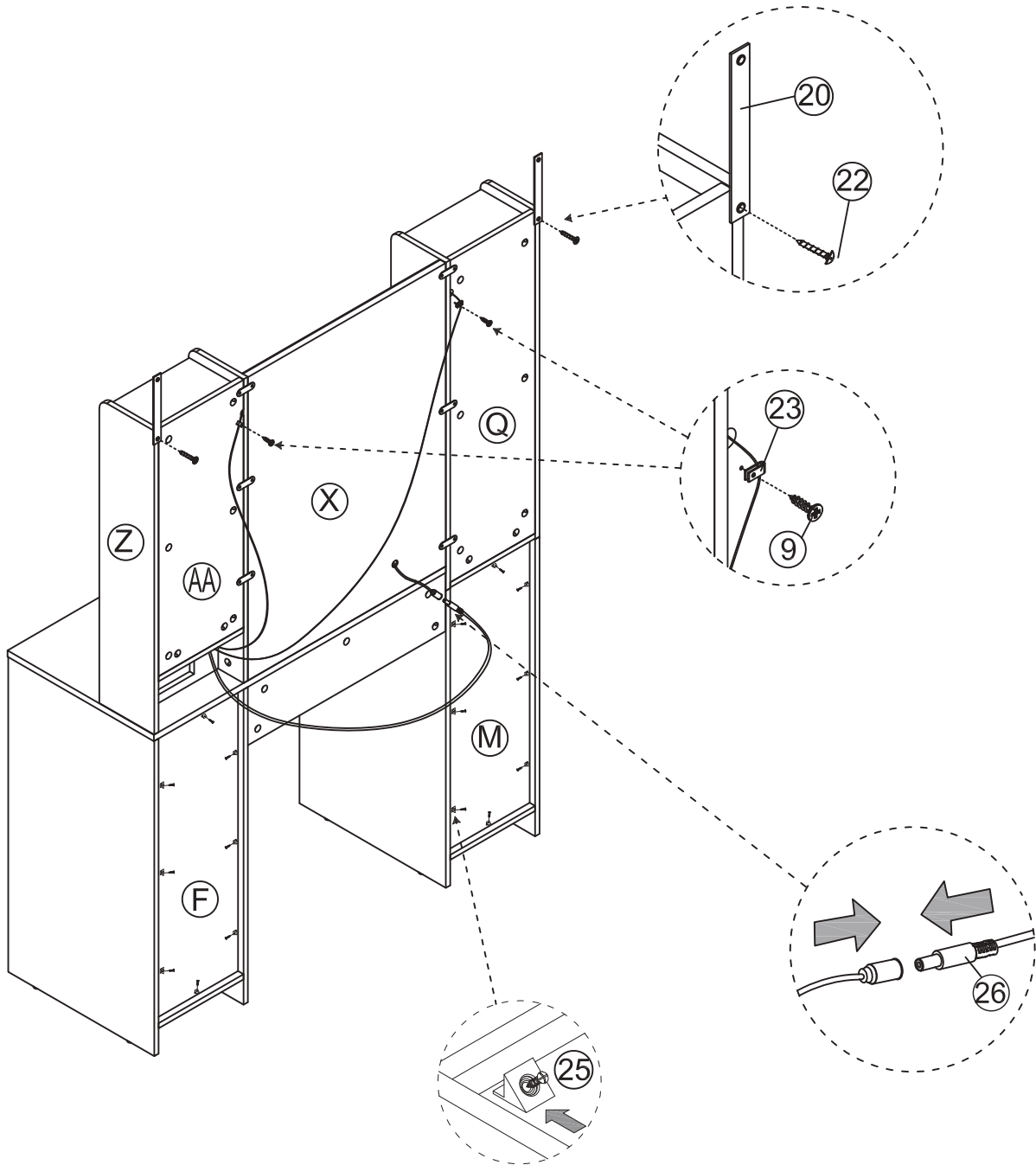

# STEP32

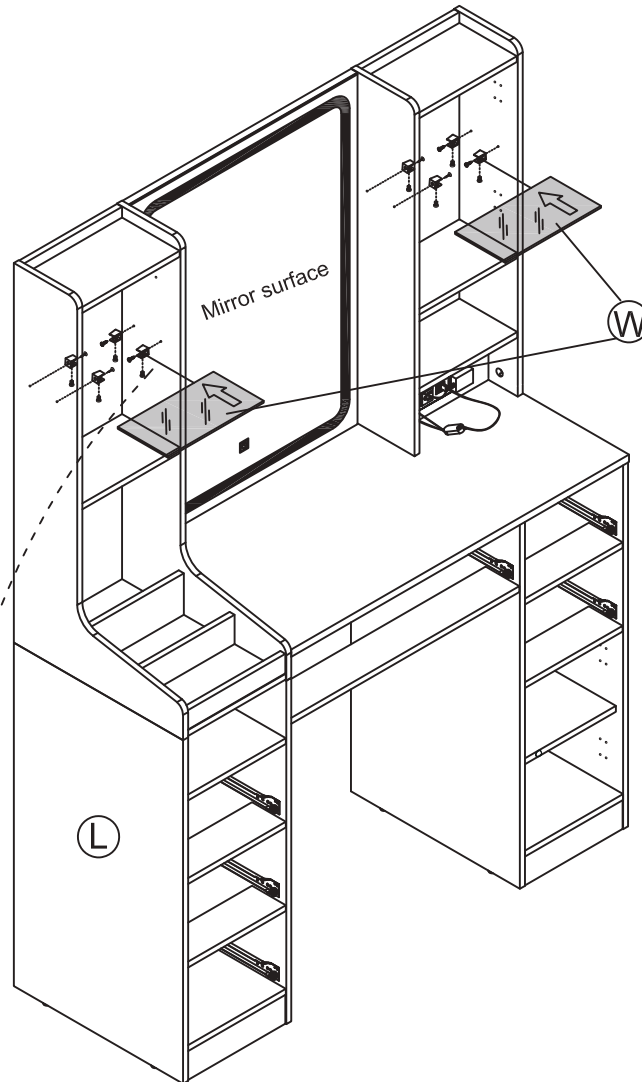
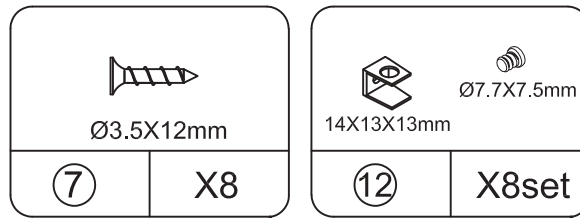

## Step 1

Fix 12# with 7# Screw

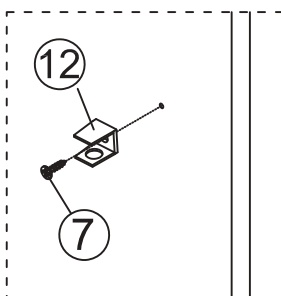

## Step 2

Put the W part into 12# slot

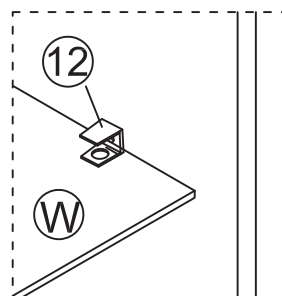

## Step 3

Rotate 12# to secure the W part

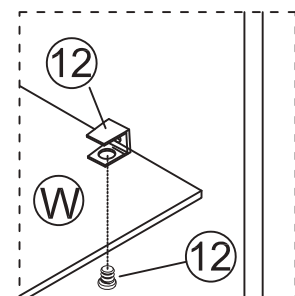

# STEP33

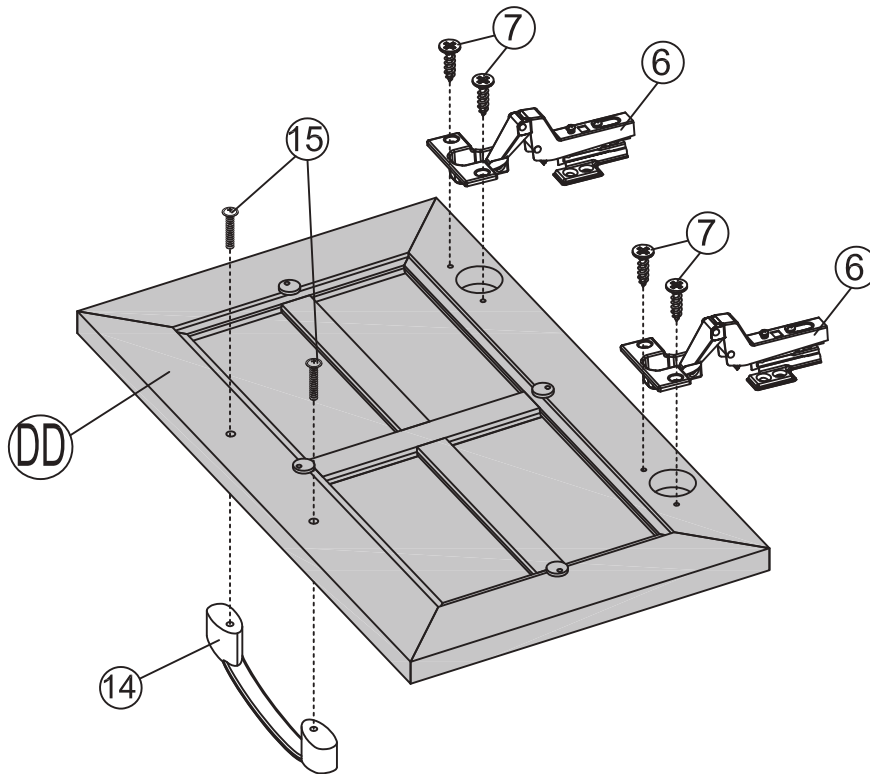
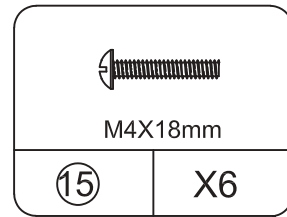
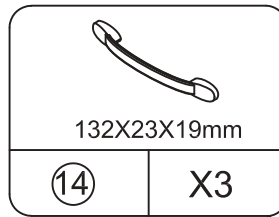
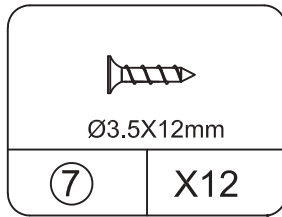
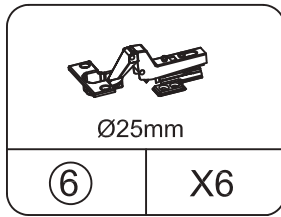

X2

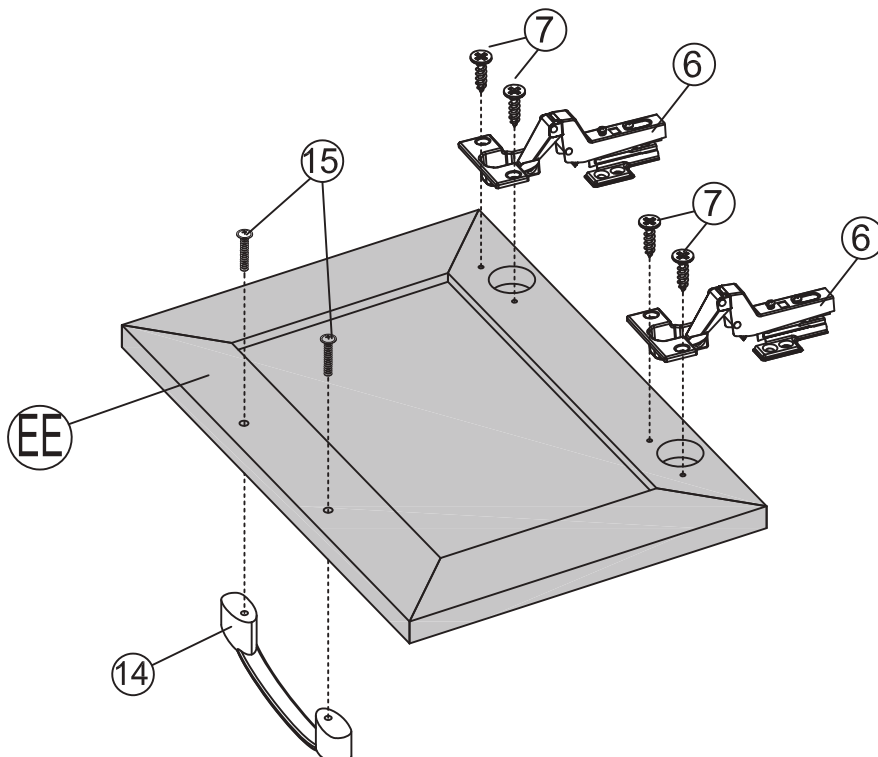

# STEP34

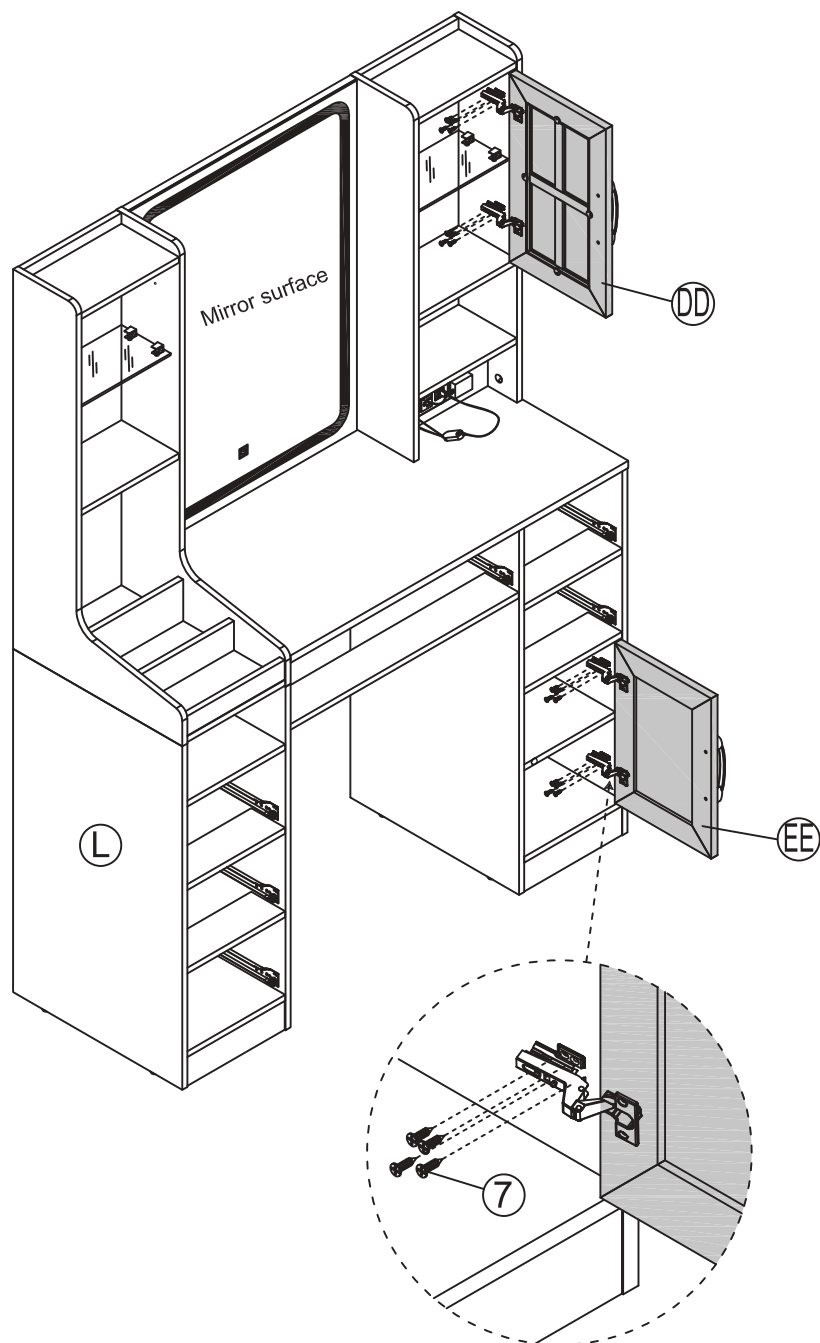
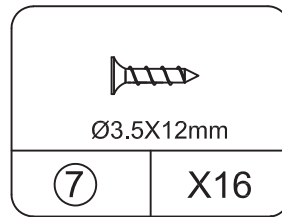

# STEP35

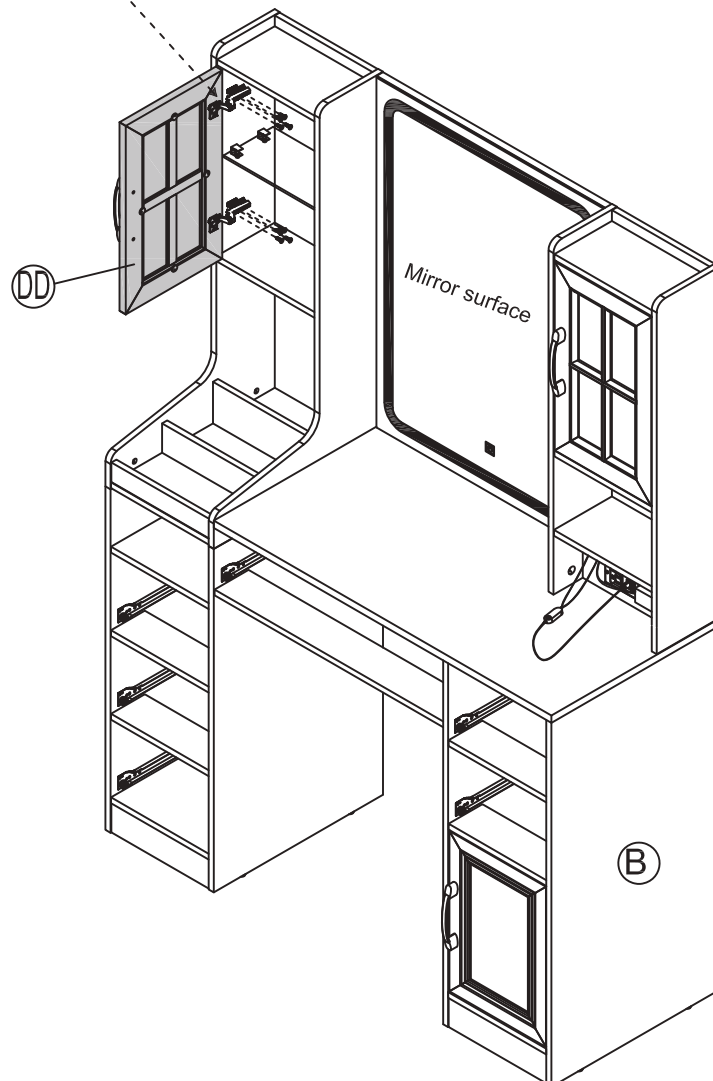
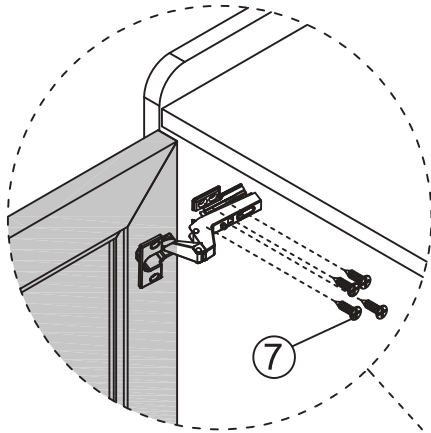
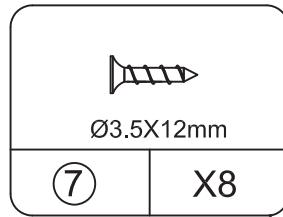

# STEP36

---

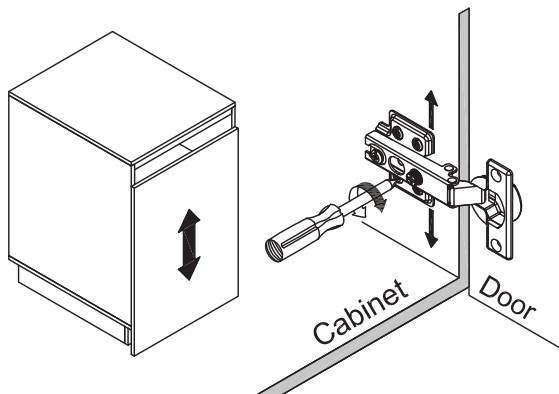
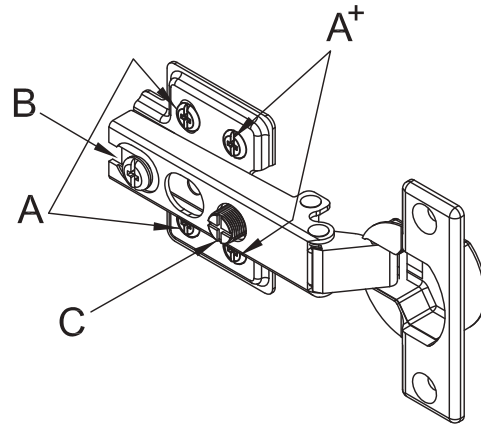

[ How to adjust vertical height of the door ]

- First remove the 2 screws "A+" on the hing .
- Then loosen the 2 screws "A" on the hinge so that it can be adjusted up or down a few millimeters.
- Then tighten "A" and reinstall "A+".

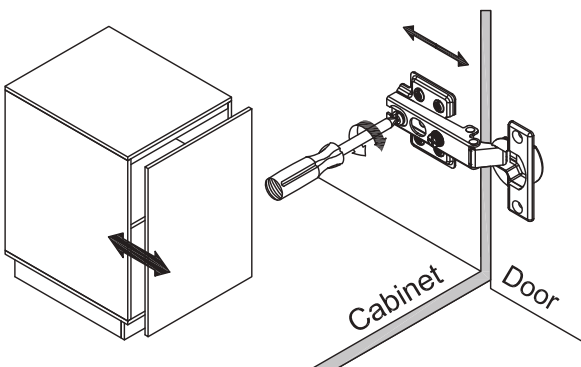

[ How to adjust depth of the door ]

- Loosen screw "B" and adjust the depth of th door.
- If screw "B" is loose, the depth of the door stil cannot be adjusted. Simply loosen the screw "C" slightly to adjust the position of the door forward and backward.
- After adjusting the position, tighten screw "B" last.

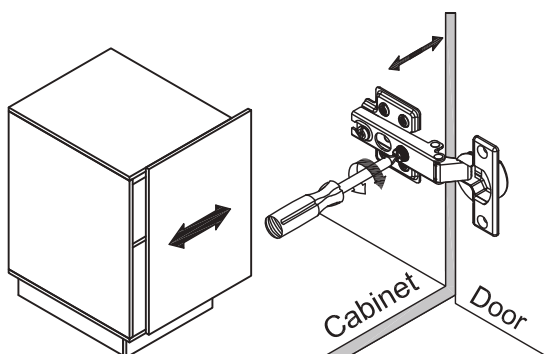

[ How to adjust the level of the door ]

- Turn screw "C" on hinge to adjust the level of

# STEP37



Ø15X9.5mm

①	X20
---	-----

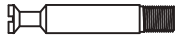

Ø6.5X35mm

②	X20
---	-----

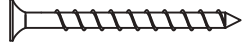

Ø4X35mm

⑩	X20
---	-----



Ø29X24mm

⑯	X5
---	----



M4X8mm

⑰	X5
---	----

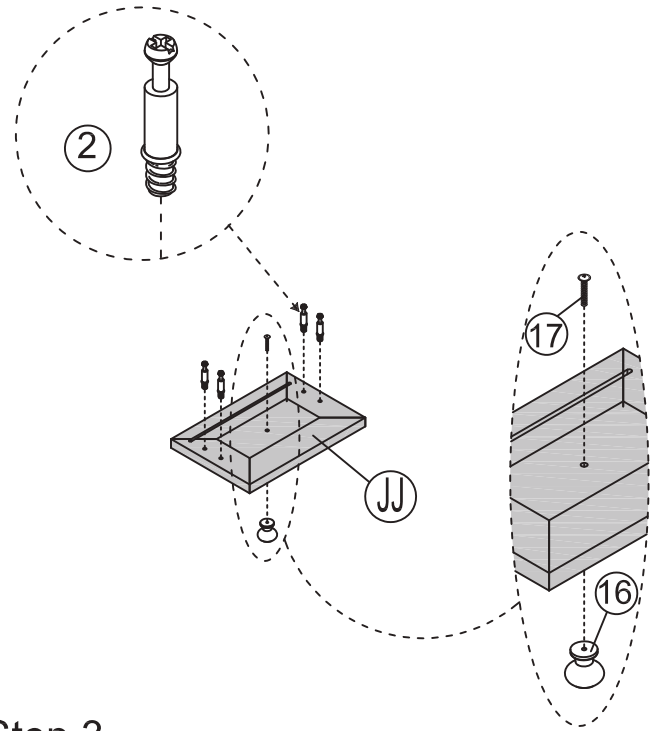
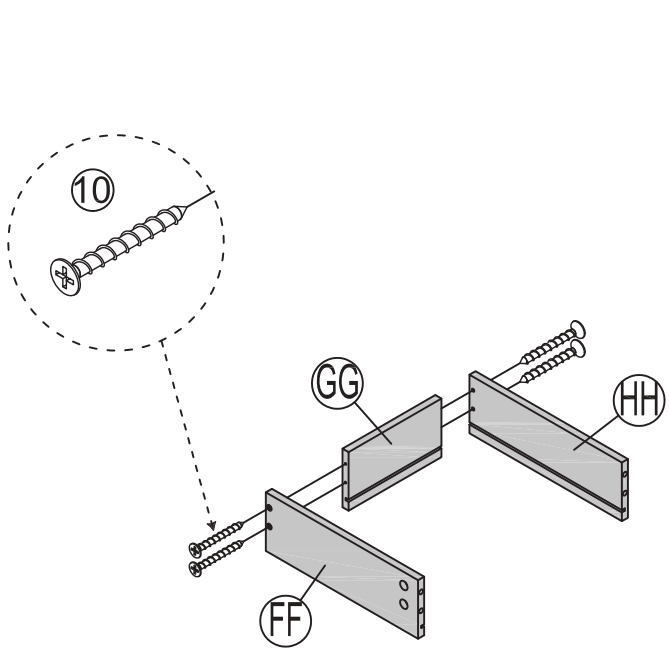

Step 1    Step 3  
Step 2    Step 4

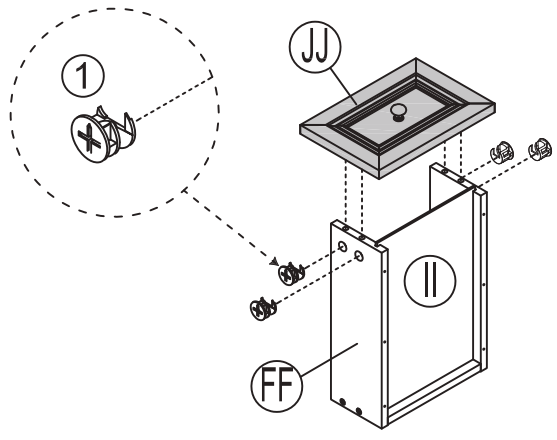
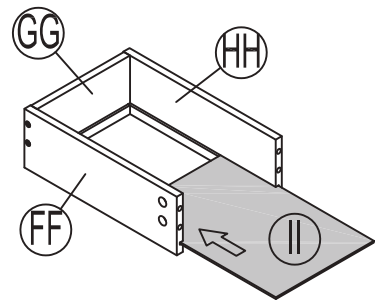

Insert the cam bolt into the hole first, then insert the cam lock and lock it.

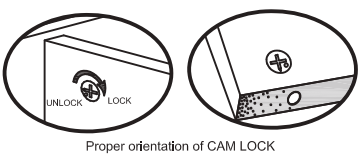

**X5**

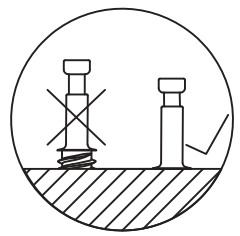

# STEP38

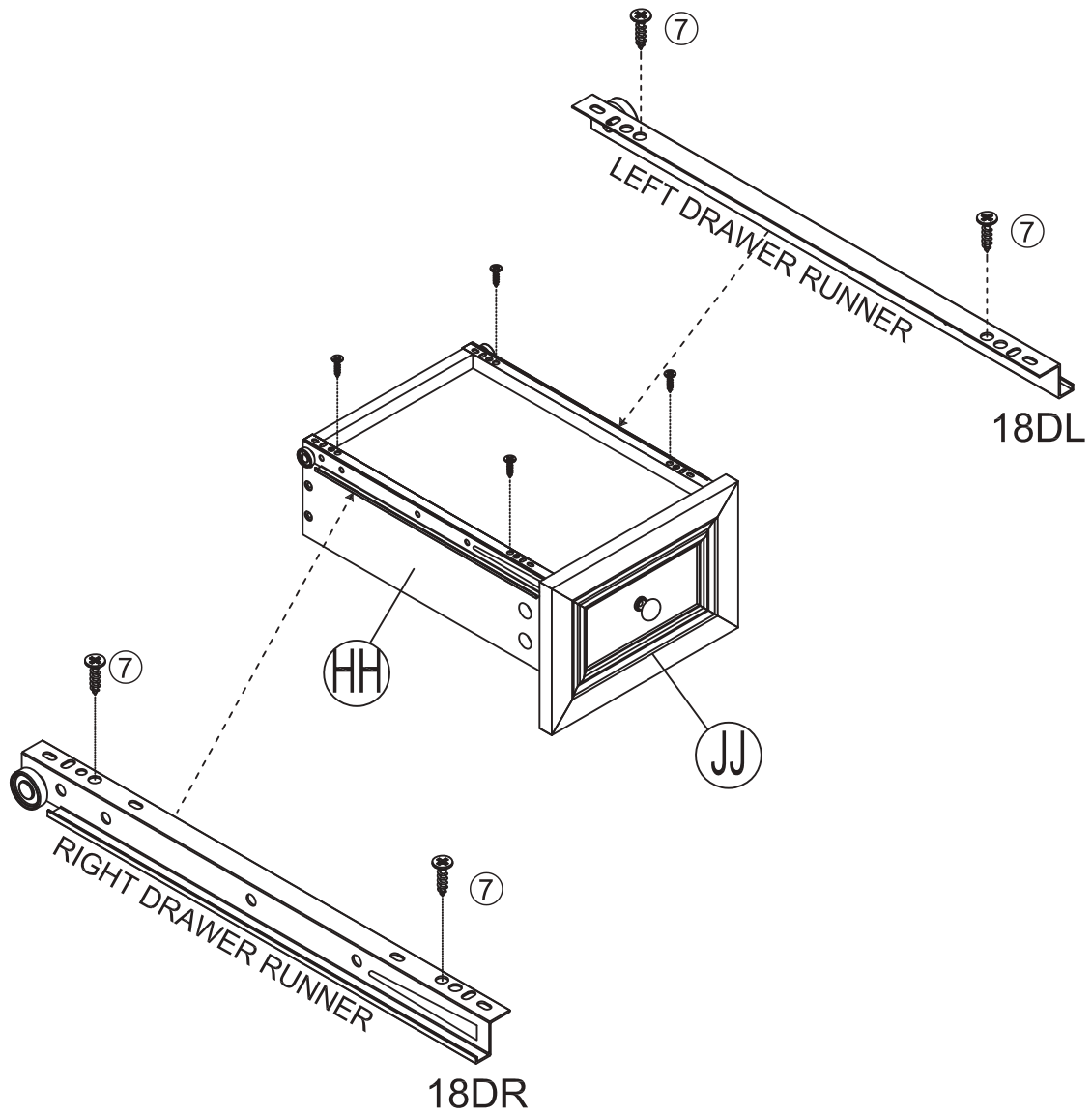
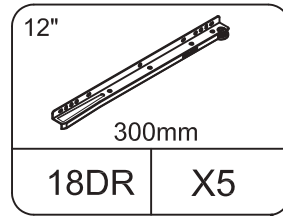
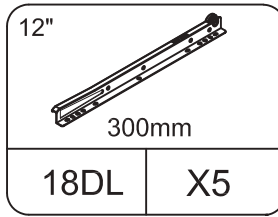
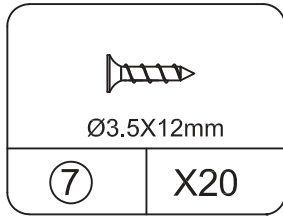

X5

# STEP39



Ø15X9.5mm

①	X4
---	----

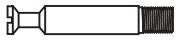

Ø6.5X35mm

②	X4
---	----

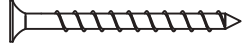

Ø4X35mm

⑩	X4
---	----



132X23X19mm

⑭	X1
---	----



M4X8mm

⑰	X2
---	----

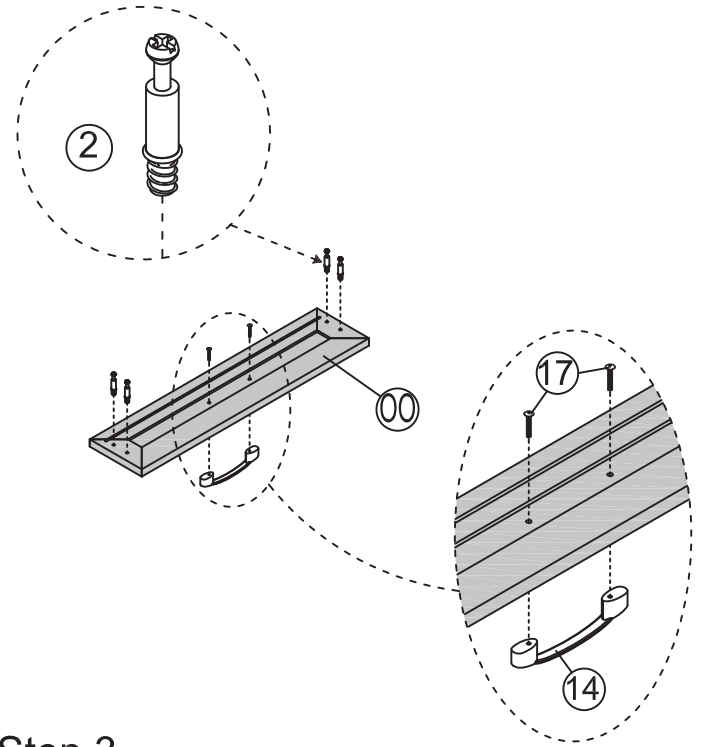
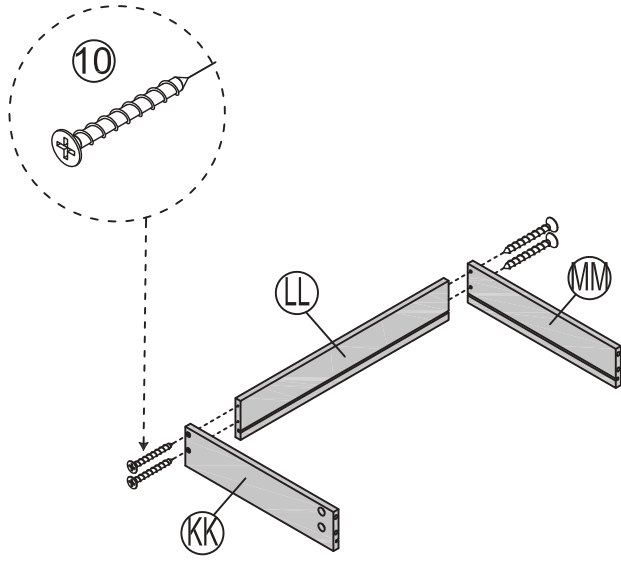

Step 1    Step 3

Step 2    Step 4

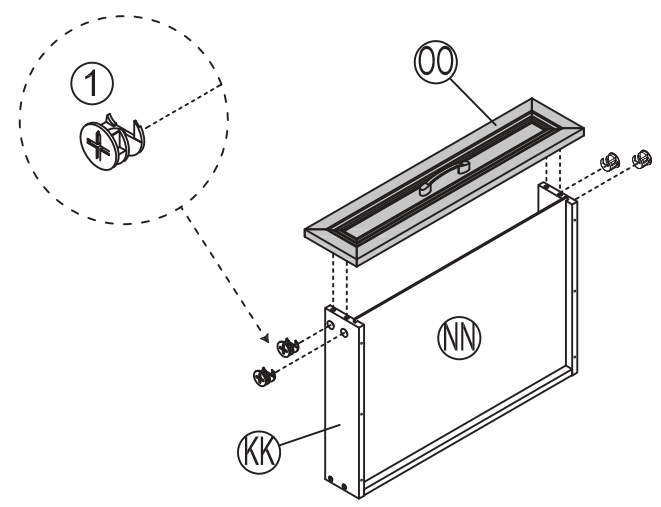
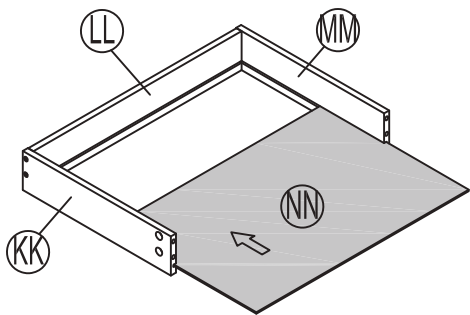

Insert the cam bolt into the hole first, then insert the cam lock and lock it.

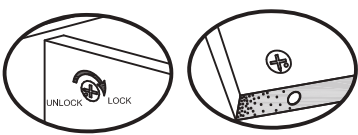

Proper orientation of CAM LOCK

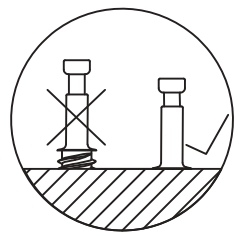

# STEP40

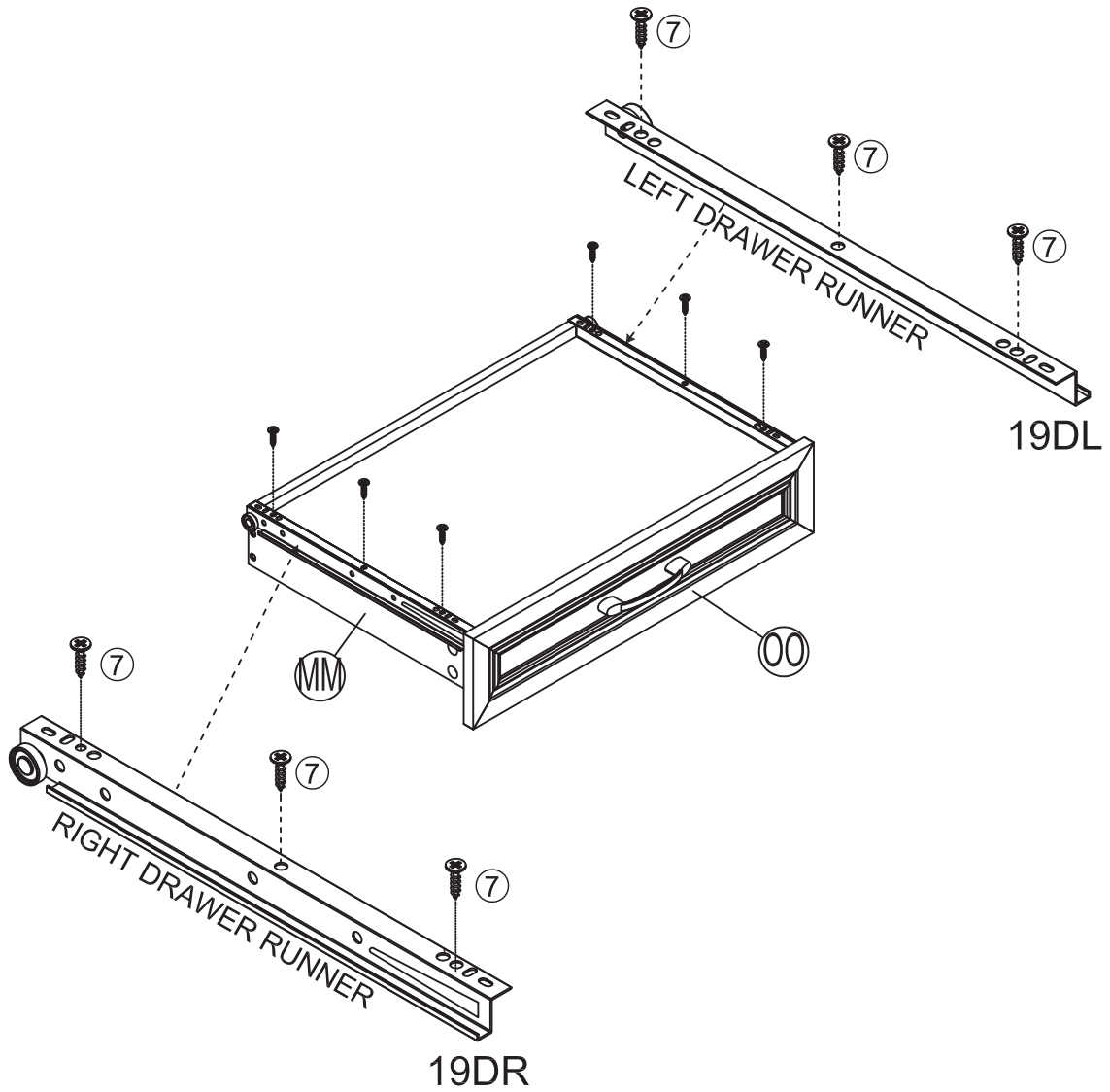
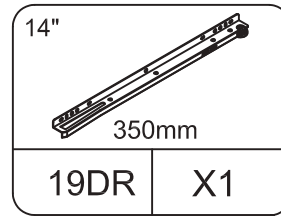
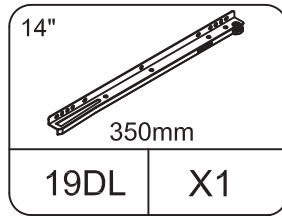
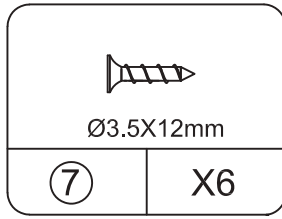

# STEP41

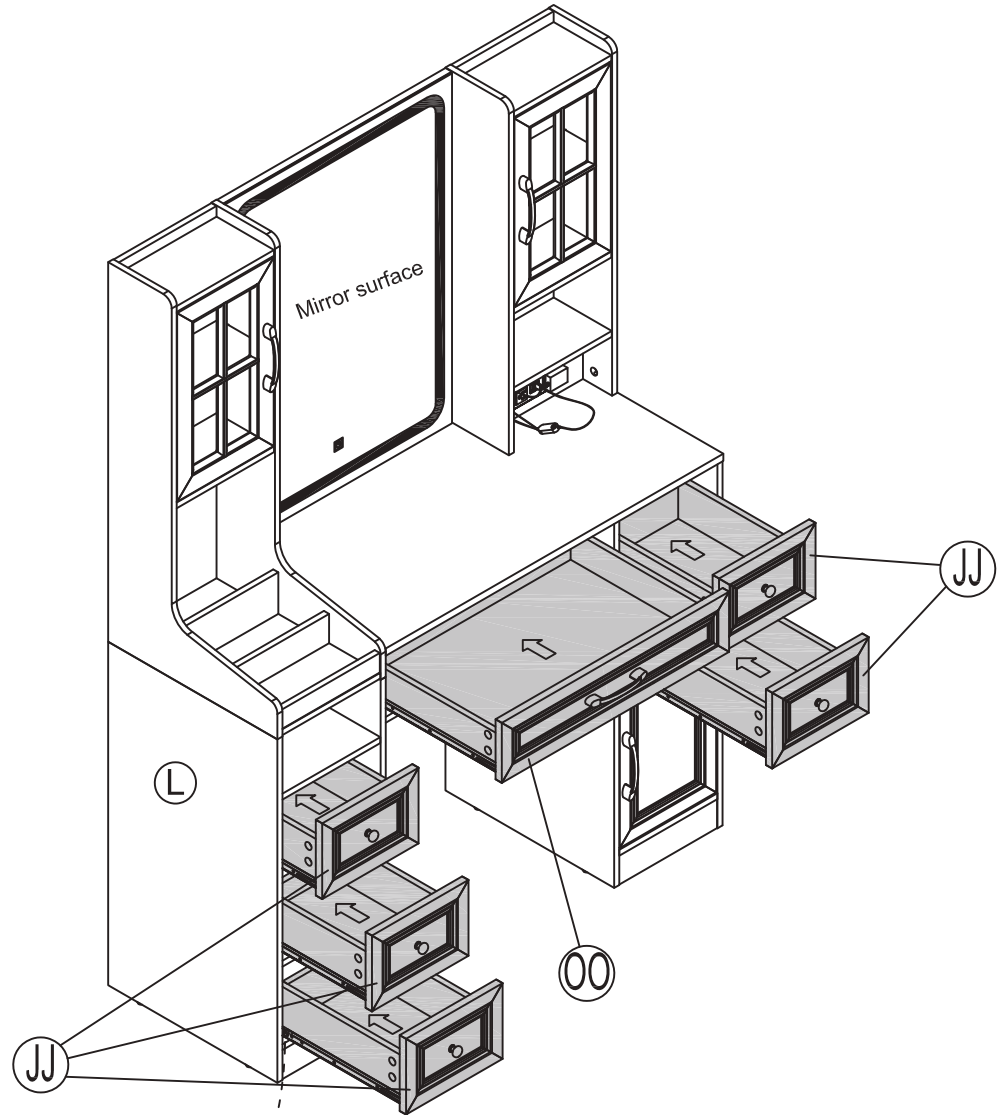

Cabinet Slide

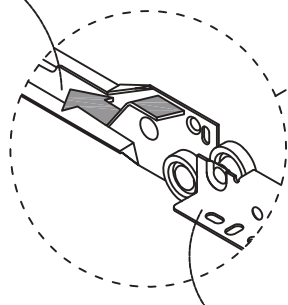

Drawer Slide

# STEP42

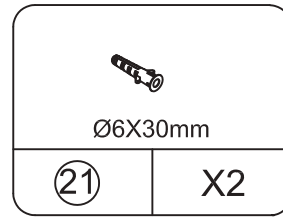
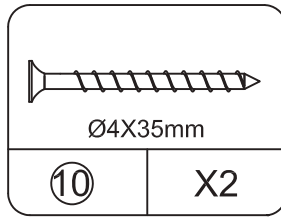

## Install the tipping restraint hardware

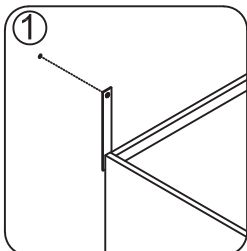

1. make mark on the wall

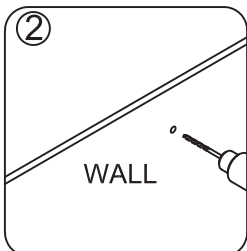

2. drill one Ø6 holes on the wall

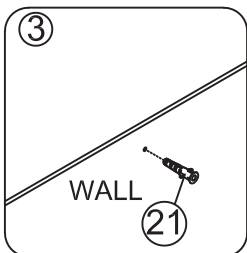

3. put one anchors in the holes

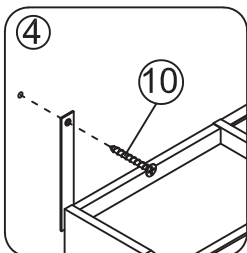

4. fix the device on the wall by the long screws

