

SAFETY INFORMATION



Please read and understand this entire manual before attempting to assemble, operate or install the product.



WARNING

- Some steps are more easily handled with two adults.

CAUTION

- Before assembly and/or installation, carefully unwrap all parts.
- Locate and set aside the hardware kit before discarding packaging.
- Use care when assembling your new product. Take your time and follow assembly instructions closely.

INFORMATION DE SÉCURITÉ



Assurez-vous de lire et de comprendre l'intégralité du présent manuel avant de tenter d'assembler, d'utiliser ou d'installer le produit.



AVERTISSEMENT

- Certaines étapes sont plus faciles à effectuer avec l'aide.

MISE EN GARDE

- Avant l'assemblage et/ou l'installation, vous devez déballer minutieusement toutes les pièces.
- Localisez et mettez de côté le jeu de quincaillerie avant de jeter l'emballage.
- Soyez vigilant lorsque vous assemblez le nouveau produit. Prenez votre temps et suivez attentivement ces instructions.

INFORMACIÓN DE SEGURIDAD



Lea y comprenda completamente este manual antes de intentar ensamblar, usar o instalar el producto.



ADVERTENCIA

- Algunos de los pasos se pueden realizar con mayor facilidad entre dos adultos.

PRECAUCIÓN

- Antes del ensamblaje y/o instalación, desenvuelva cuidadosamente todas las piezas.
- Localice y separe el equipo de accesorios antes de desechar el embalaje.
- Tenga cuidado al ensamblar el nuevo producto. Tómese su tiempo y siga detenidamente las instrucciones de ensamblaje.

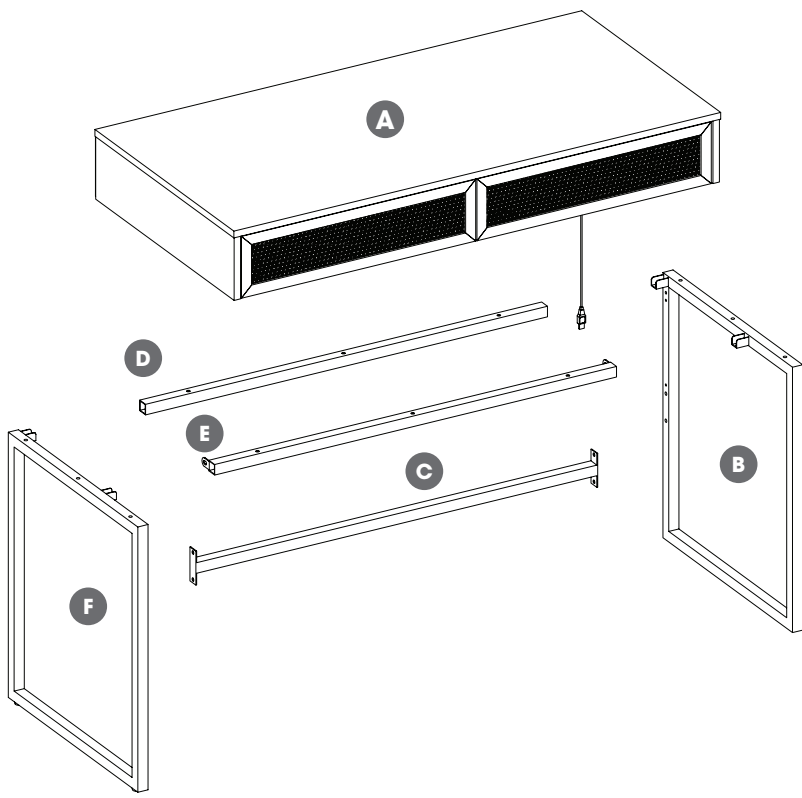

MAXIMUM LOAD
18.2 kg / 40 lbs
CHARGE MAXIMALE
18.2 kg / 40 lbs
CARGA MÁXIMA
18.2 kg / 40 lbs

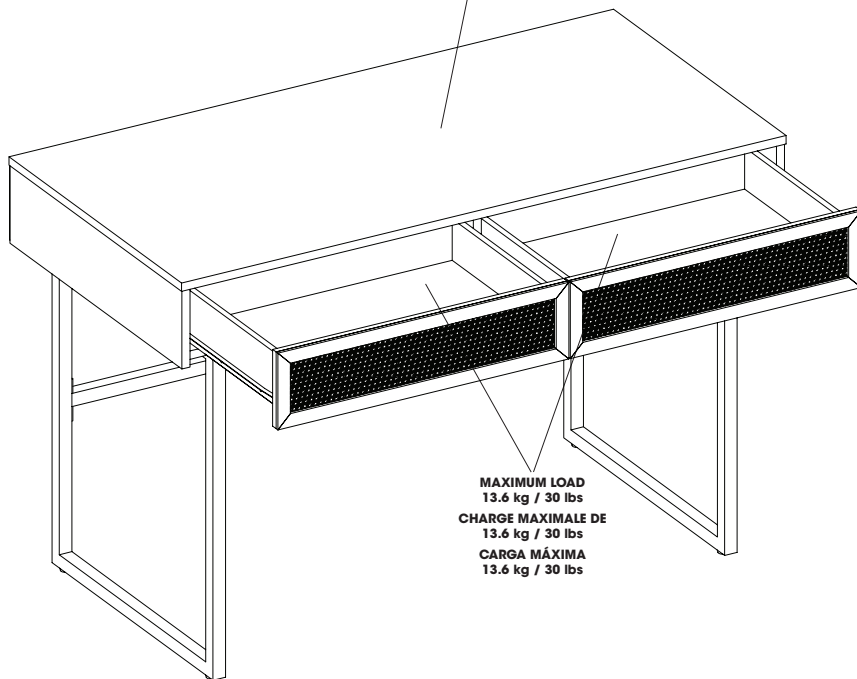

MAXIMUM LOAD
13.6 kg / 30 lbs
CHARGE MAXIMALE DE
13.6 kg / 30 lbs
CARGA MÁXIMA
13.6 kg / 30 lbs



WARNING

Loads heavier than the maximum weights specified may result in instability causing tip over resulting in death or serious injury.

ATTENTION

Des charges dont le poids dépasse les valeurs spécifiées peut entraîner l'instabilité et le basculement pouvant provoquer la mort ou des blessures graves.

PRECAUCIÓN

Cargas mayores que los pesos máximos especificados puede generar inestabilidad y, en consecuencia, desplomes que pueden causar la muerte o lesiones graves.

HARDWARE / QUINCAILLERIE / FERRETERÍA

AA

[x12]



Ø6.3x12mm

BB

[x12]

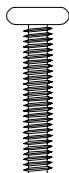

Ø6.3x35mm

CC

[x2]



DD

[x2]



Ø3.5x12mm

EE

[x1]



FF

[x2]

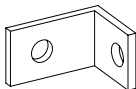

ATTENTION: Follow instructions in the order they are given below. This will ensure that your product is properly assembled. To reduce the risk of damage to your furniture, please lay down a blanket, cloth, or cardboard on the floor prior to assembly.

ATTENTION: Suivre les instructions dans l'ordre donné ci-dessous. Cela vous assurera d'assembler correctement le produit. Para reducir el riesgo de daño a sus muebles, por favor coloque una manta, tela o cartón en el suelo antes del montaje.

ATENCIÓN: Siga las instrucciones en el orden que se indica a continuación. Esto asegurará que su producto se ensamble correctamente. Pour réduire le risque d'endommager vos fournitures, veuillez les poser sur un tapis, un tissu ou un carton sur le sol avant l'assemblage.

1

AA [x4]

EE

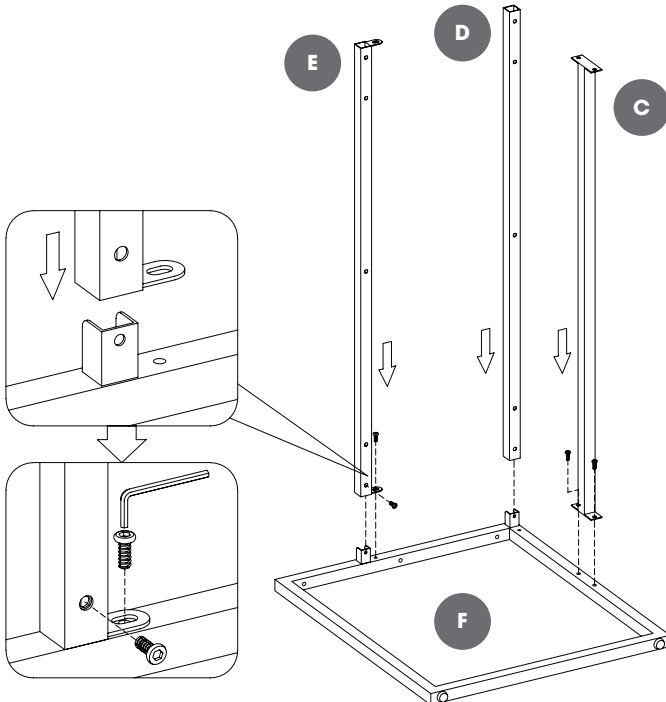

2

AA



[x4]

EE

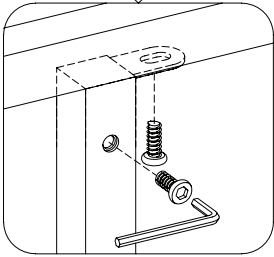
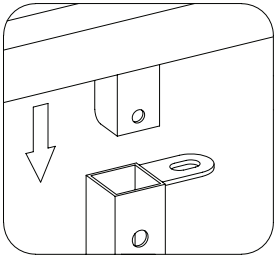
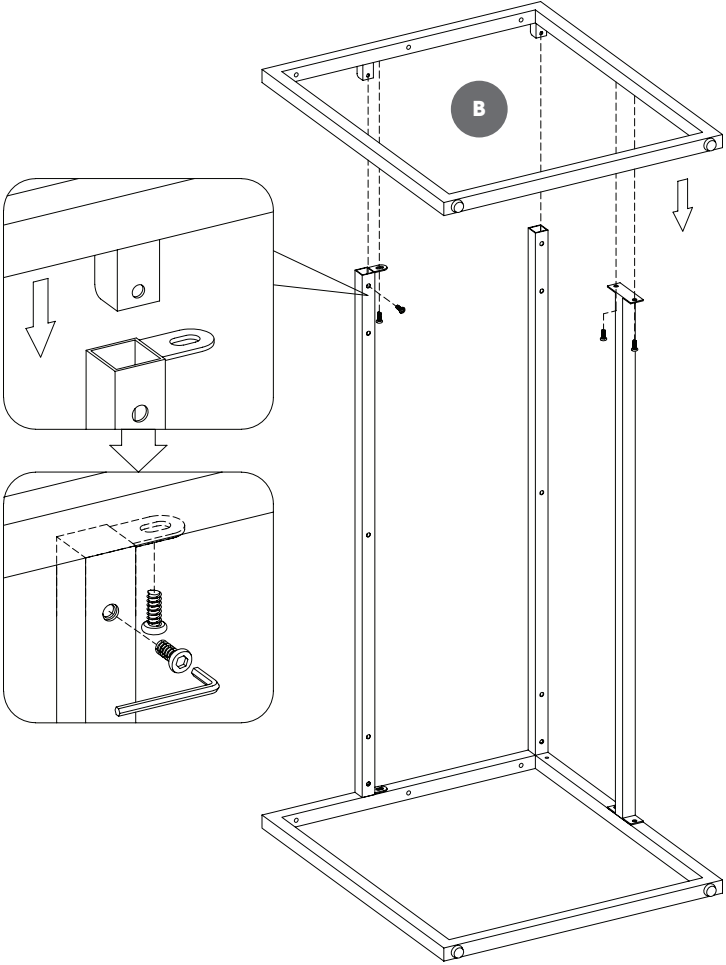
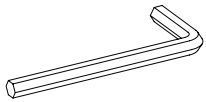

3

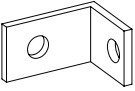
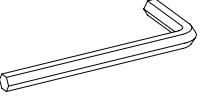
- AA**  **[x4]**
- FF**  **[x2]**
- EE** 

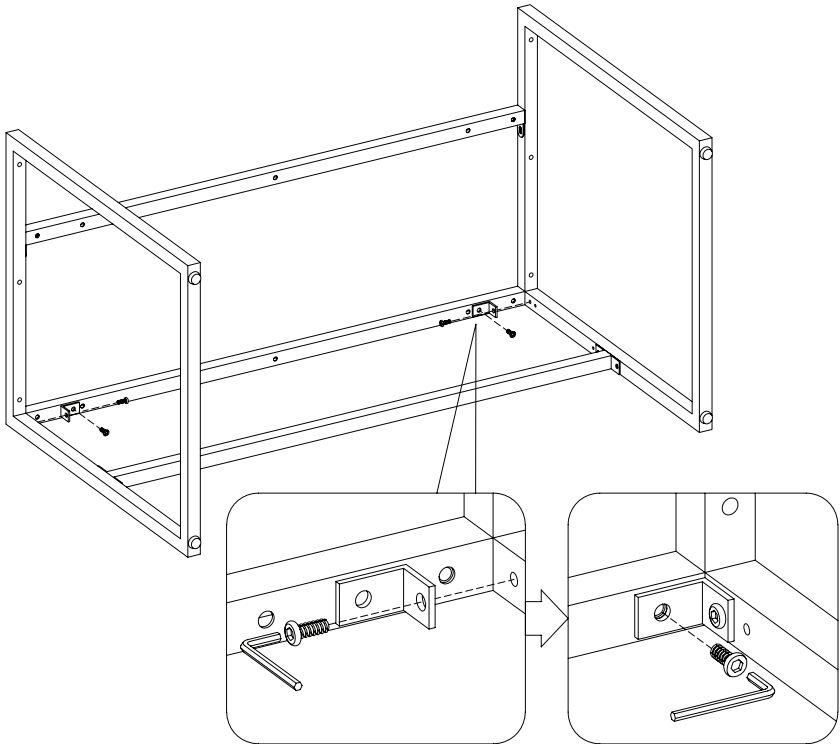

4

BB

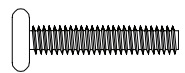

[x12]

EE

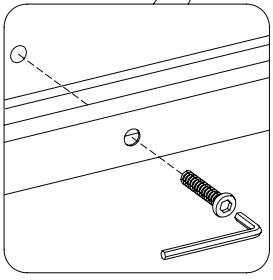
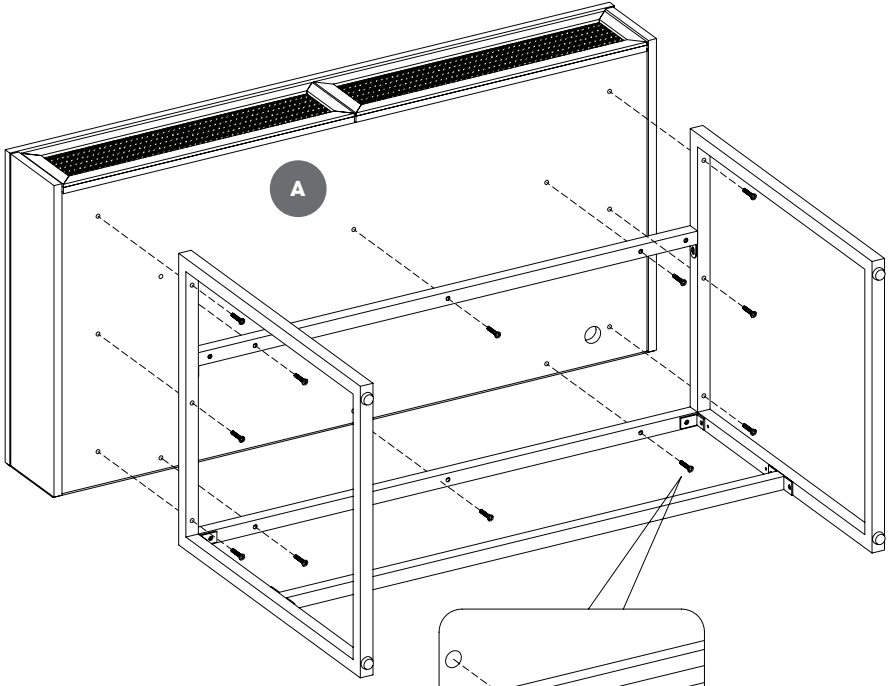
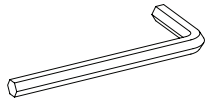

5

DD



[x2]

CC

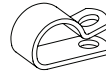

[x2]

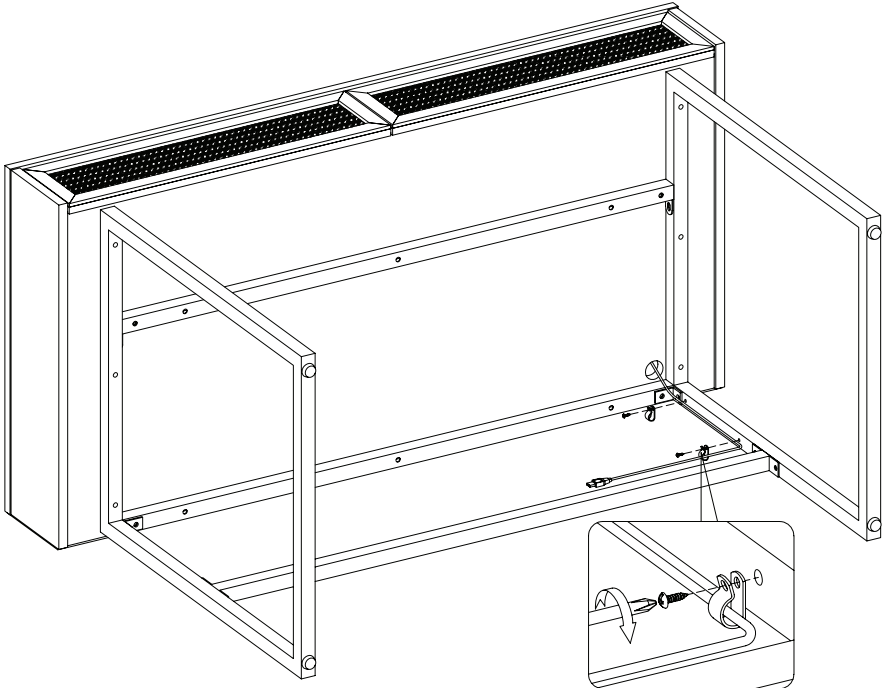

6

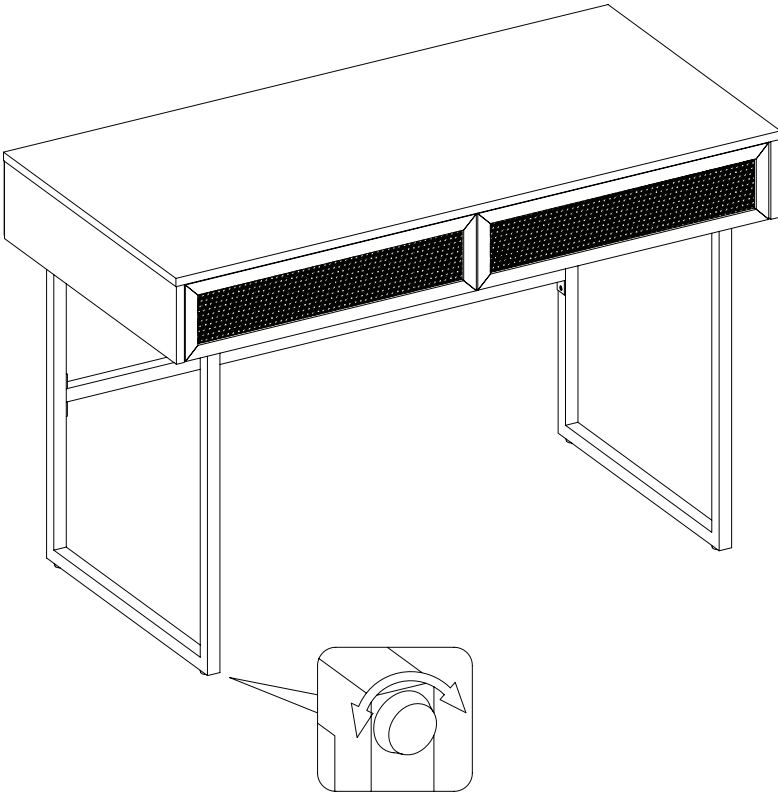

Note: It is very important that your unit is properly leveled. After moving your unit to its final location, you may need to adjust the floor levelers.

Note: Il est très important que votre unité soit au niveau correctement. Après avoir déplacé votre unité à son emplacement final, vous devrez peut-être ajuster les niveleurs de plancher.

Nota: Es muy importante que su unidad esté nivelada correctamente. Después de mover su unidad al lugar definitivo, debe ajustar la nivelación del piso.

GG

[x12]



HH

[x4]

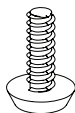

II

[x1]

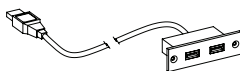

JJ

[x2]

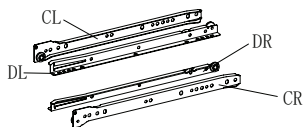

KK

[x4]

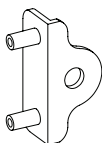

F

[x1]

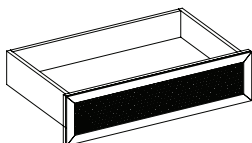

G

[x1]

