

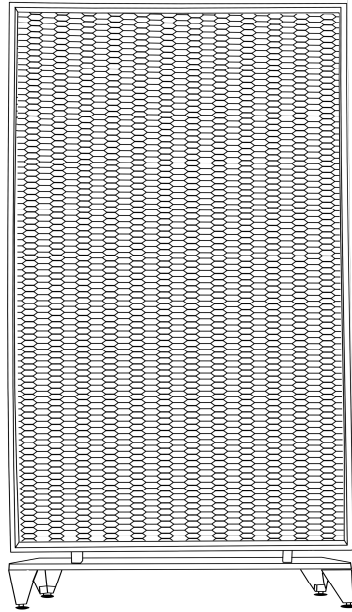

Screen



Parts List

Label	Picture	Description	QTY
A	A close-up view of the top portion of the screen, showing the grid of metal rings.	Screen Top	1
B	A close-up view of the bottom portion of the screen, showing the grid of metal rings and the bottom edge of the frame.	Screen Bottom	1
C	A close-up view of the base plate, which is a flat, rectangular metal plate with two small circular holes.	Base	1
D	A close-up view of one of the legs, which is a metal piece with a black cap on top and a circular hole at the bottom.	Legs	4

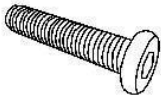
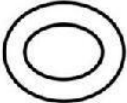
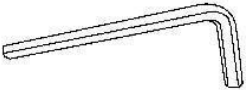
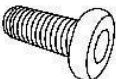
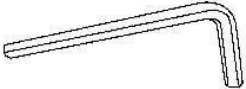
Hardware

Label	Picture	Description	QTY
①		Bolt (M8x30mm)	3
②		Flat Spring	3
③		Allen Wrench(M8)	1
④		Bolt (M6x10mm)	9
⑤		Allen Wrench(M6)	1
⑥		Connect Accessories	6

Assembly Preparation

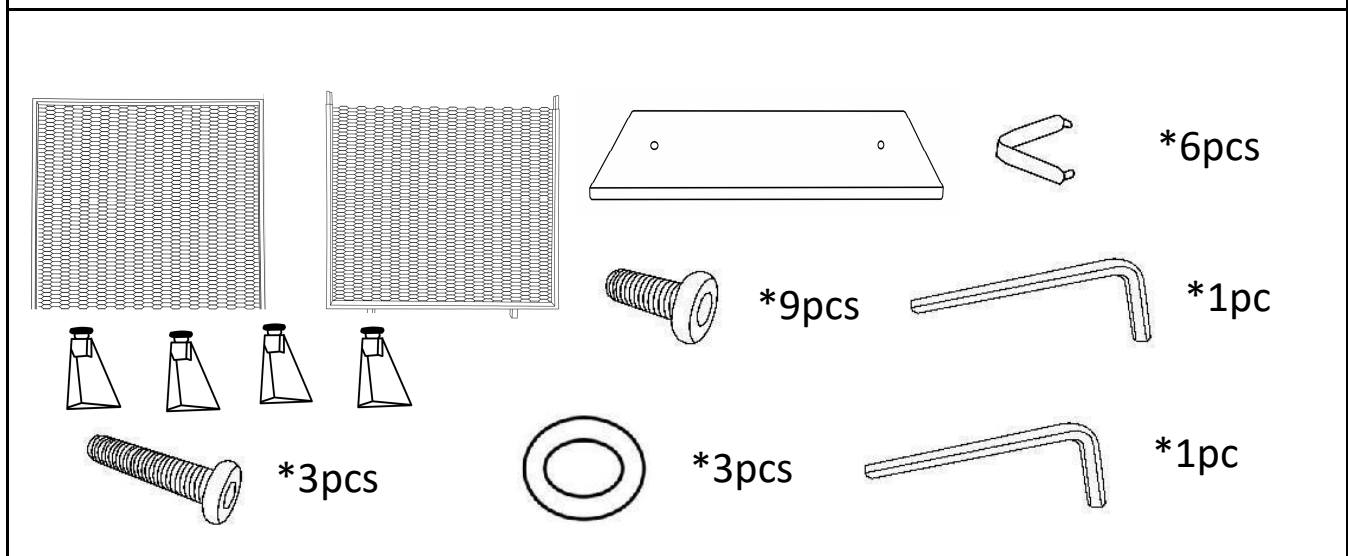



- Read instructions, cover to cover-



- Have 2 adults on hand for assembly-



- Do not assemble on flooring or carpet-



- Assemble on a clean non-marring surface (packing foam)-



- Save all packaging until finished-

Assembly Steps

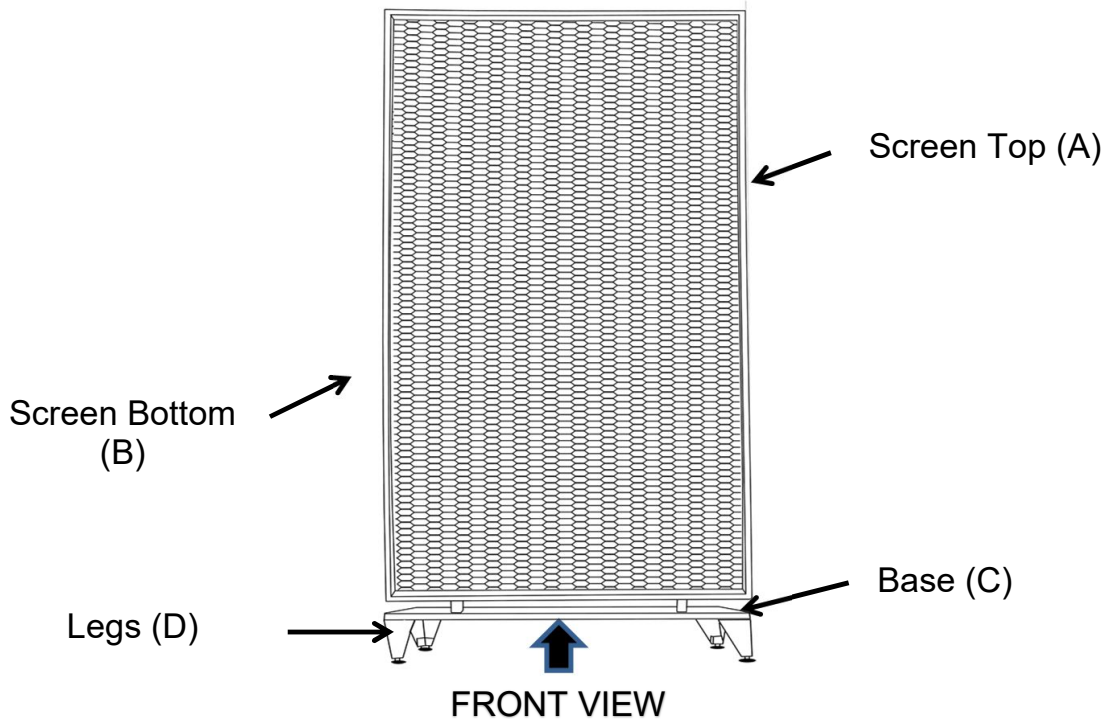

This Screen has multiple parts and may require up to some 30 minutes to assemble. To give you an overview of the Screen parts, the above picture is to help you put the various parts into perspective.

Please read through the instructions herebelow to familiarise the parts and steps before assembly.

Step 1

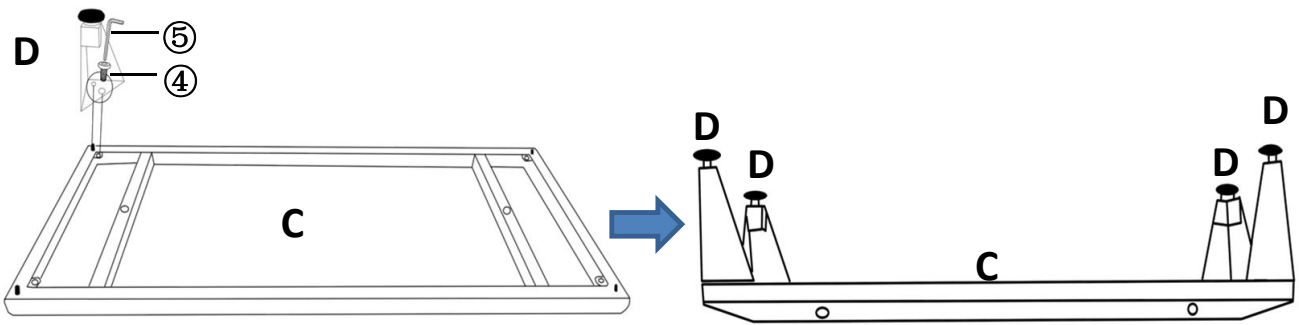

Unpack and place all parts on a clean non-marring surface.

Turn the Base (C) upside down. Attached Legs (D) to Base (C) using Bolts (4) with Allen Wrench (5).

Step 1

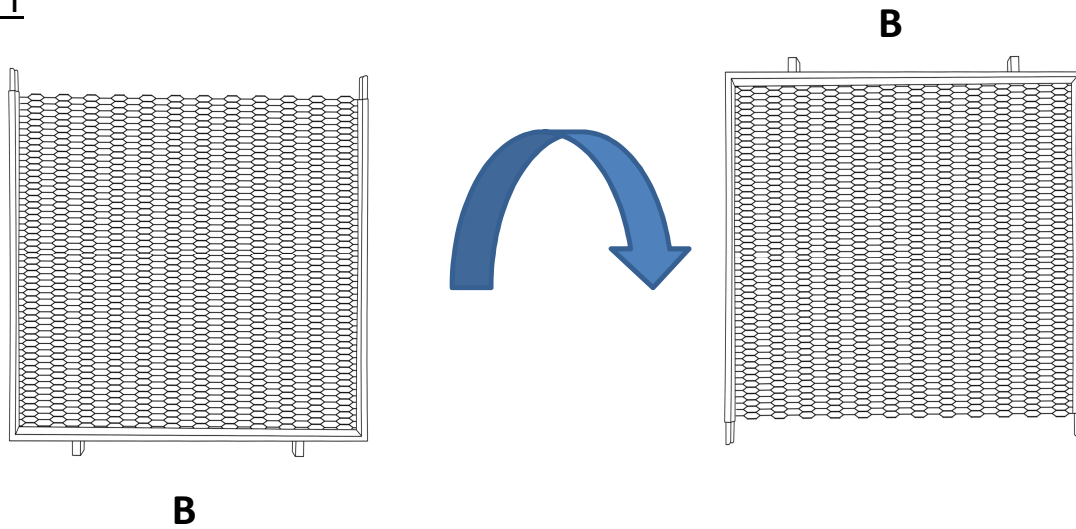

Unpack and place all parts on a clean non-marring surface.

Turn the Screen Bottom (B) upside down.

Step 2

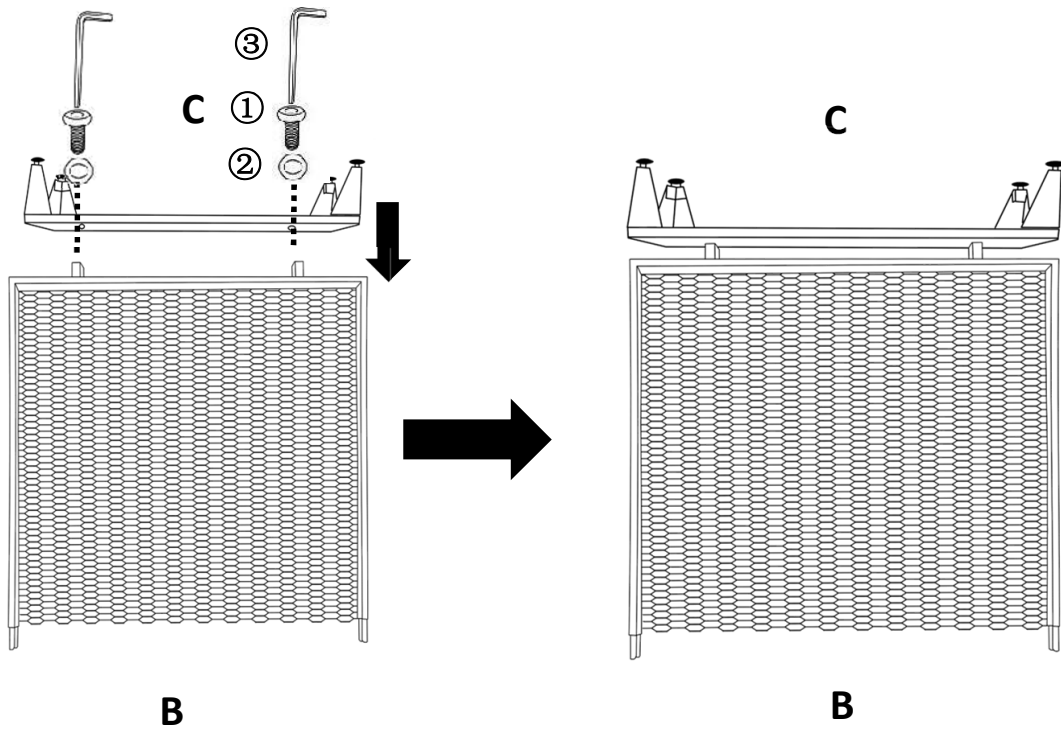

Attached Base(C) to Screen Bottom(B) using Bolt(①)&Flat Spring(②) with Allen Wrench(③)

Step 3

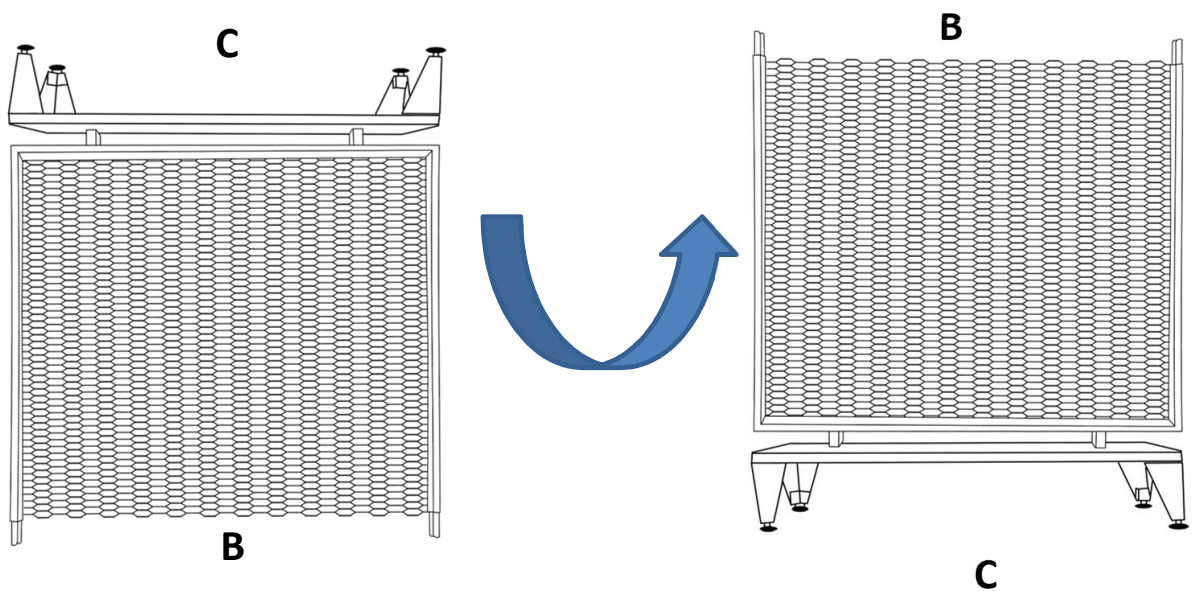

Turn the Screen Bottom (B) upside up.

Step 4

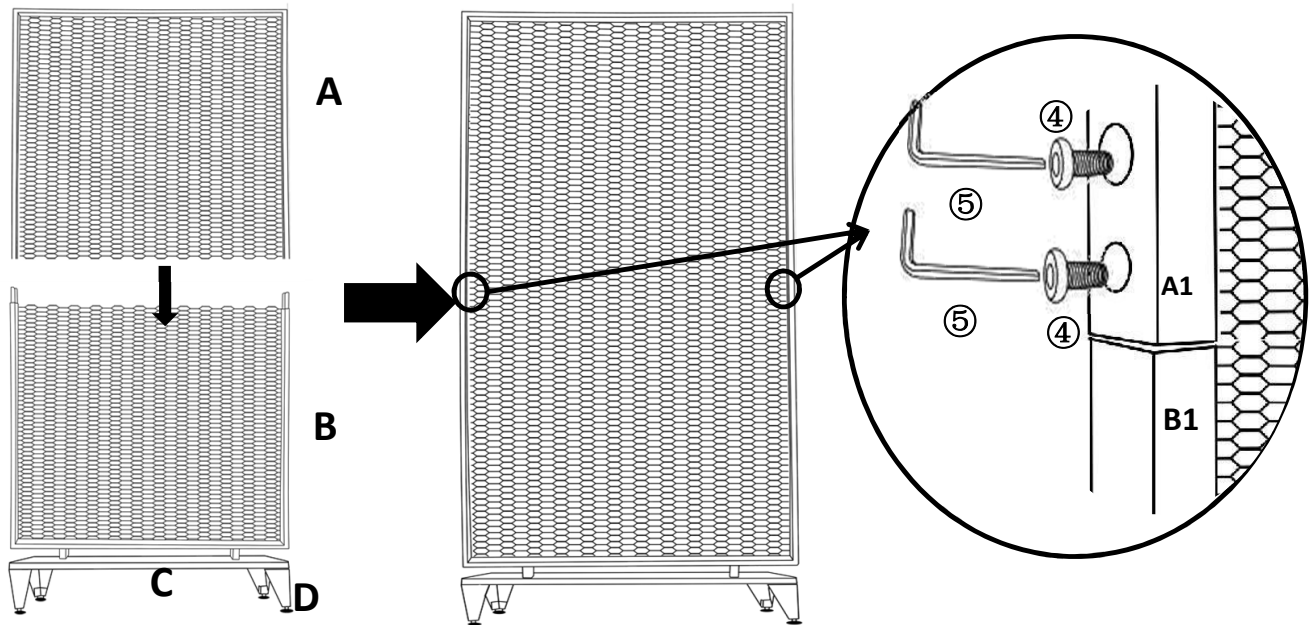

Attached Screen Top(A) to Assembled Screen Bottom(B) with Base(C) using Bolts(④) with Allen Wrench(⑤).

ATTENTION: In order to assemble smoothly, please only line up the assembly in order according to the label.A1 to B1,A2 to B2.

Step 5

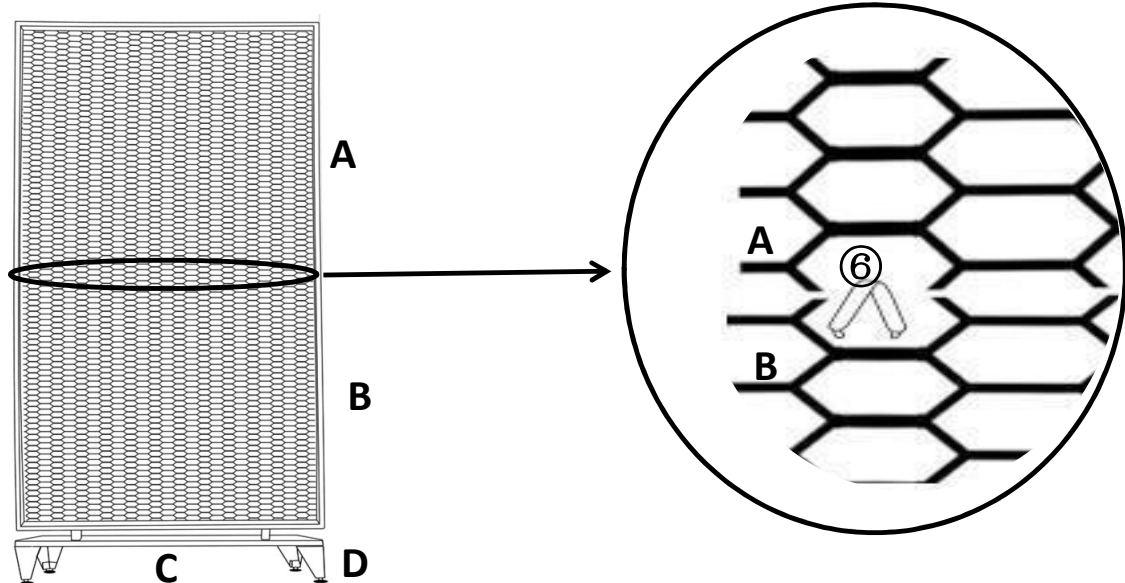

Using Connect Accessories(⑥) to secure the connection area of the two screens by hands.

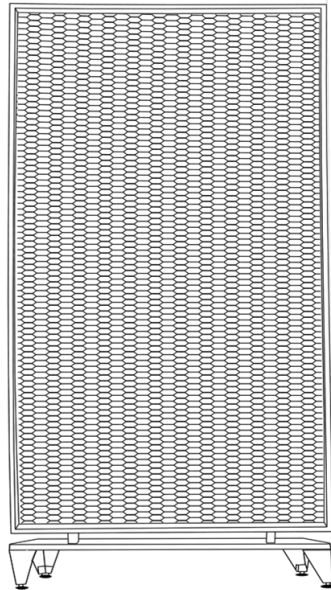

Your Screen is ready for use.

Check for stability and then tighten the Bolts.

DO NOT fully tighten a BOLT in one go and then move on to the next.

Rather, in a sequential manner, gradually tighten each Bolt until all Bolts are evenly secured.

This methodology will ensure maximum evenness once all Bolts are fully tightened.

Note: This step is done better with the assistance of a second adult.