

INSTRUCTION
ANWEISUNG

取扱説明書

600

INSTRUCTION
사용설명서



***Two people for assembly**
***Installieren zwei Personen zusammen**
***2인작업이 필요합니다**

***Two more accessories for A,B and D will be provided.**

***A, B und D Ersatzteile geben extra zwei Stück**

***부품A도 부품B도 부품D도 2개의 스페어가
동梱されています**

***부품A,B,D는 비품이 2개씩 더 준비해두
겠습니다**

***Vous aurez 2 en plus de pièce
A, B, D comme rechange.**

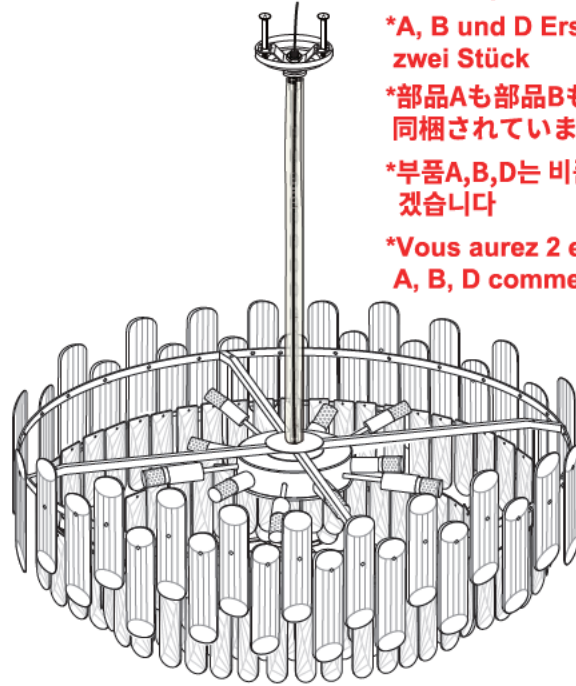

FR



ÉTUI



FR

Les ampoules
et tubes
se recyclent

À DÉPOSER
EN MAGASIN



OU

À DÉPOSER
EN DÉCHÈTERIE



Points de collecte sur www.quefairedemesdechets.fr

A *130

Small crystal
Kleiner durchsichtiger Kristall
Sサイズの無色透明な水晶
petits cristaux transparents
작은 투명한 크리스탈



B *21

Large crystals with middle hole
Großer grauer Kristall mit mittlerem Loch
灰色の水晶 (穴が中部にある)
Grand cristal gris avec trou central
미디엄 홀 그레이 크리스탈



D *21

Large crystals with top hole
Großer durchsichtiger Kristall mit seitlichem Loch
Lサイズの無色透明な水晶
Grand cristal transparent avec trou latéral
L 사이즈 무색 투명한 크리스탈

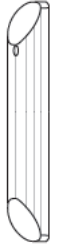

E *1



F *1

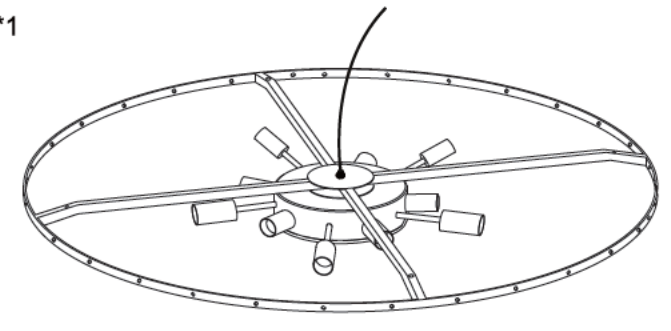

G1 *1



G2 *1



H *1

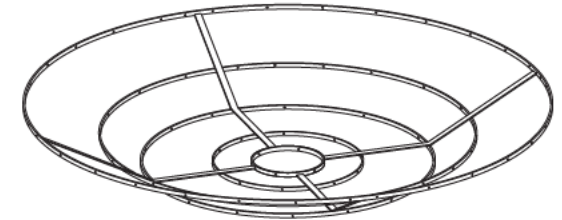

J *4



K *1



L *10



M *4



N *4



P *42



Q *42



R *42



S *130



T *1



1

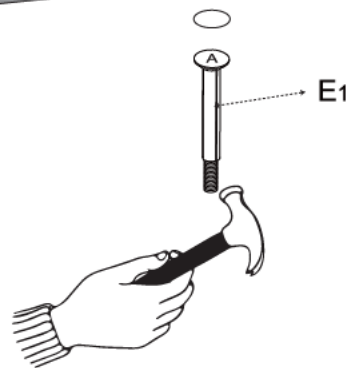
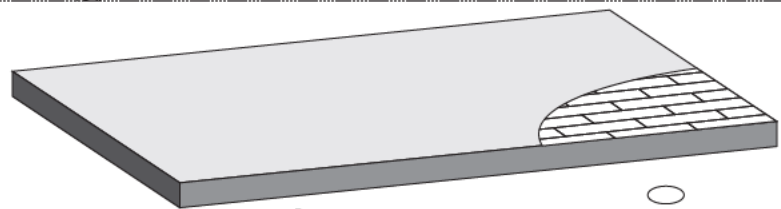
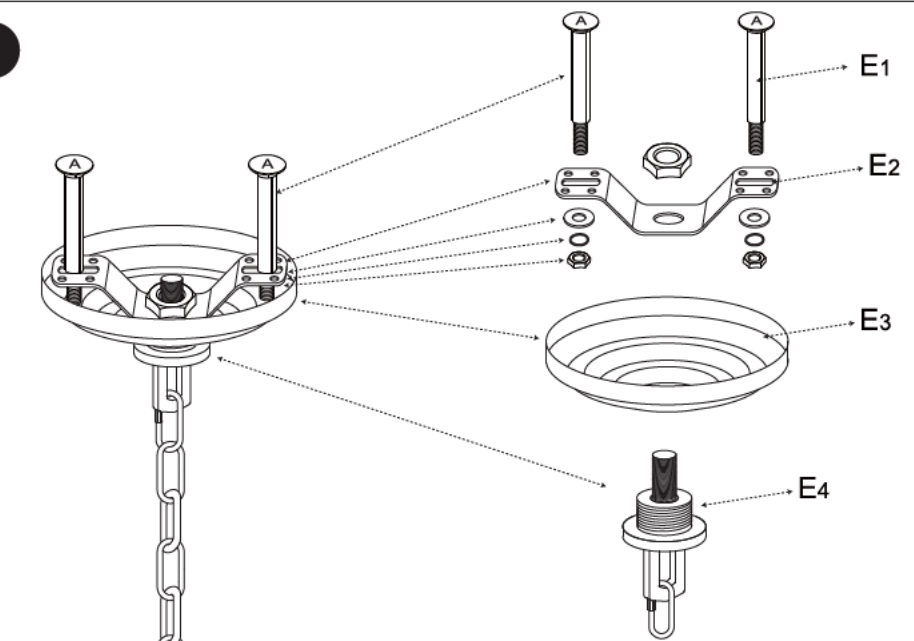

- ▶ Detach the ' Part E' as shown first
Drill the hole on the wall, hammer the E1 screw into the hole
- ▶ Teilen Sie bitte zuerst das „Zubehör E“ wie abgebildet, stanzen Sie ein Loch in die Wand und hämmern Sie die „Schraube E1“ in das Loch
- ▶ 上図のように、部品Eを分解してください。
天井に穴を開けてから、E1を穴に差し入れてください。
- ▶ Tout d'abord, séparez la "Partie E" comme indiqué.
Percez un trou dans le mur et enfoncez la "vis E1" dans le trou.
- ▶ 먼저 "부품 E"를 그림과 같이 분리하십시오.
벽에 구멍을 뚫어 "나사 E1"을 구멍에 박아 주십시오.

2

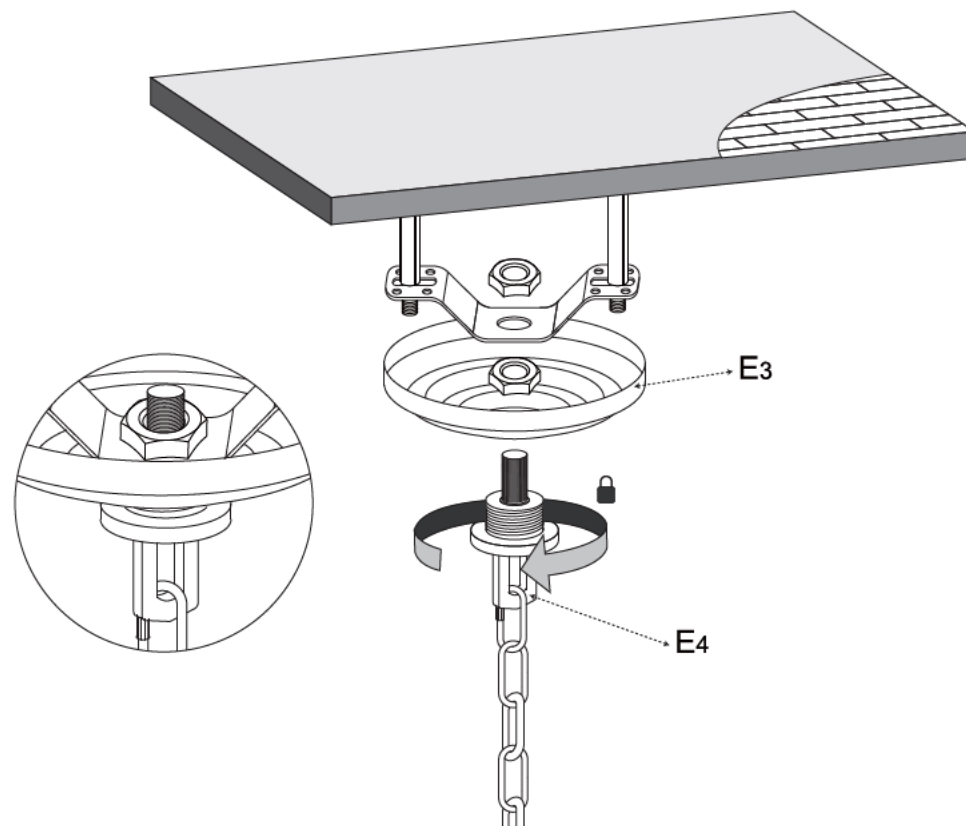
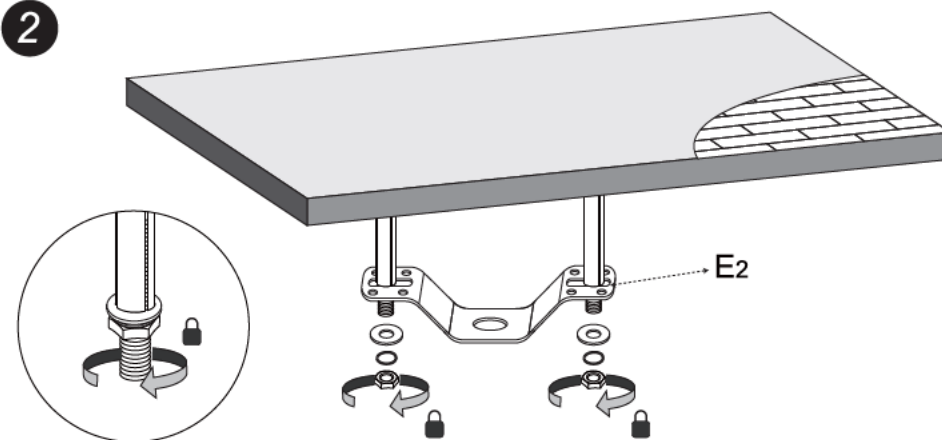

3

- ▶ electric wire
- ▶ Kabel
- ▶ 照明の電源コード
- ▶ fil
- ▶ 전선

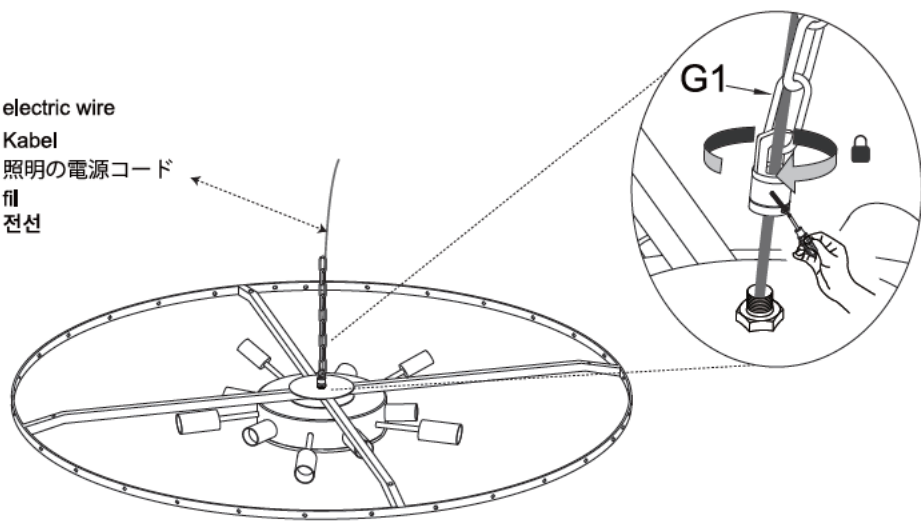

4

N*4
I

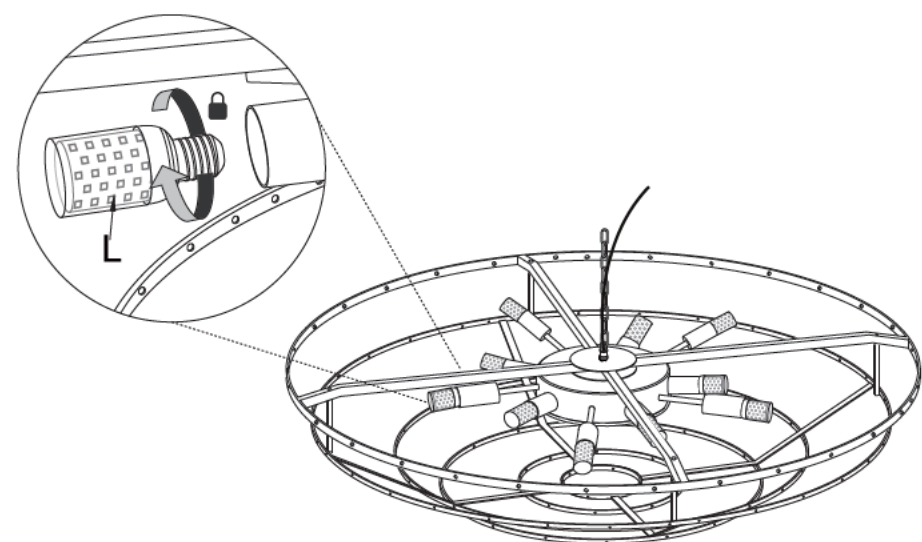
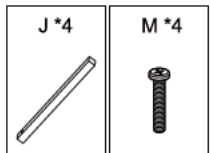
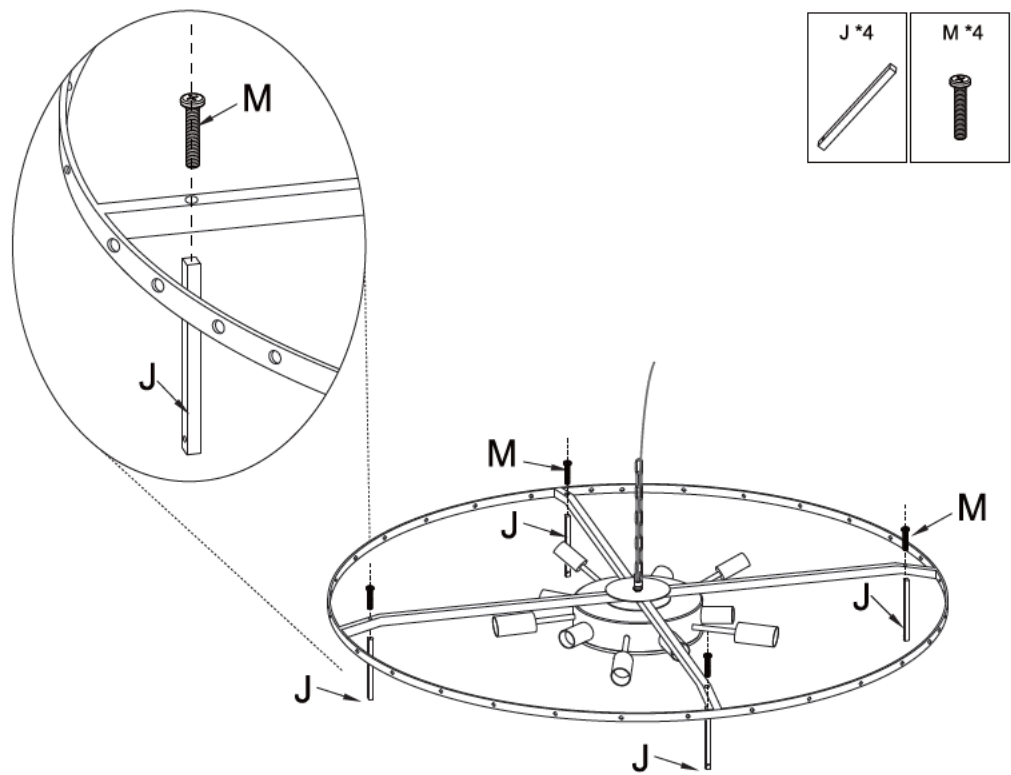
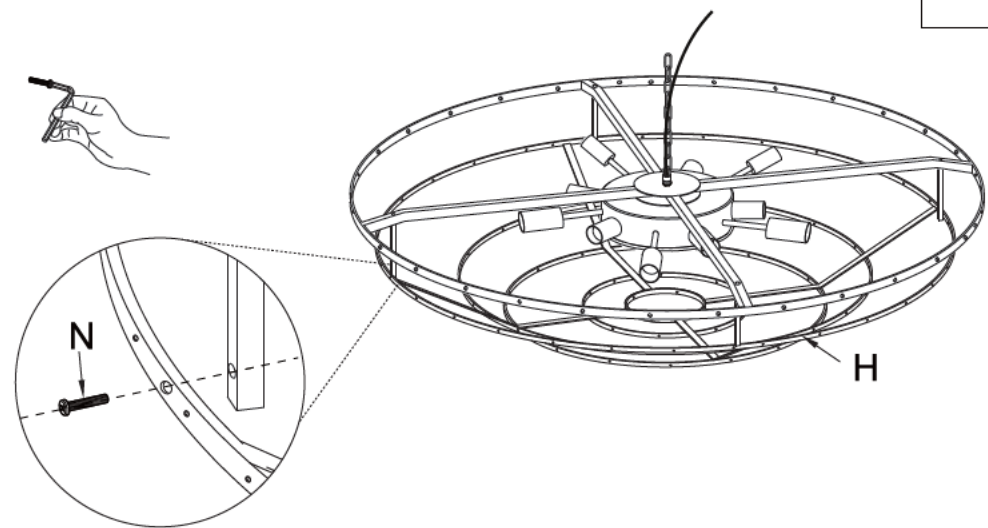

5

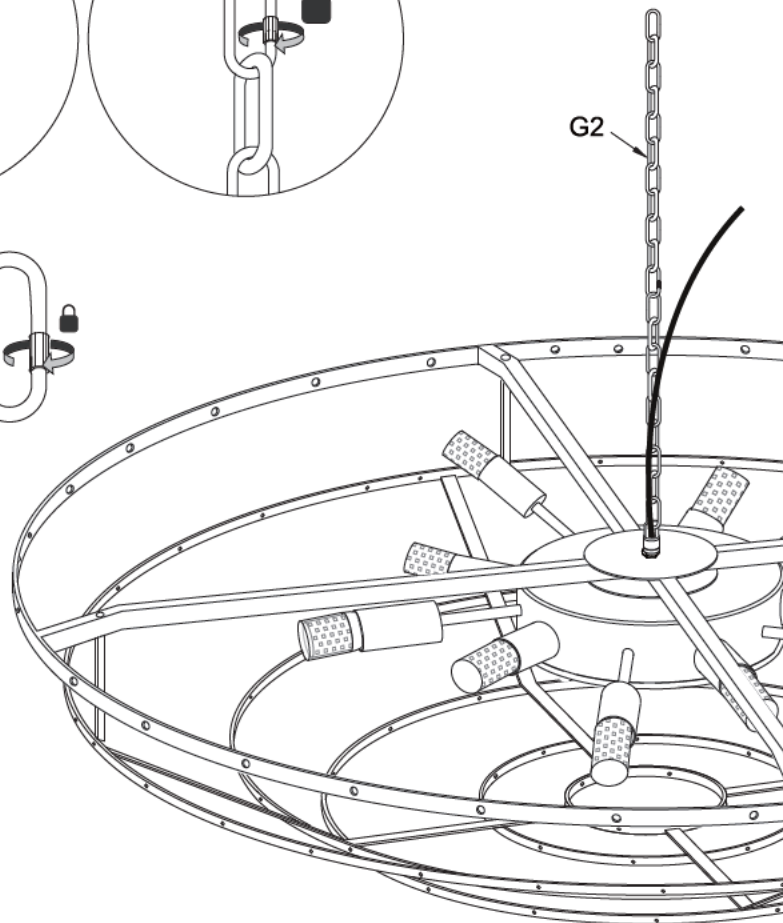
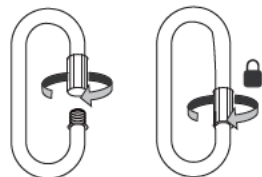
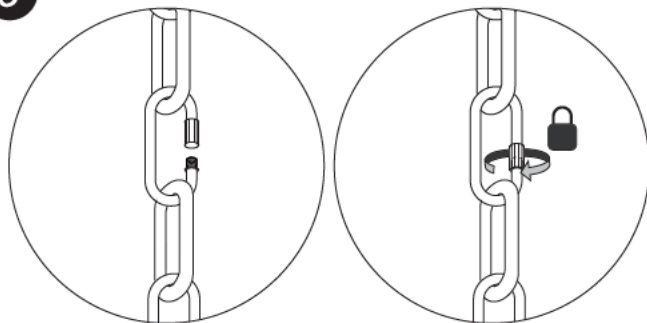

6

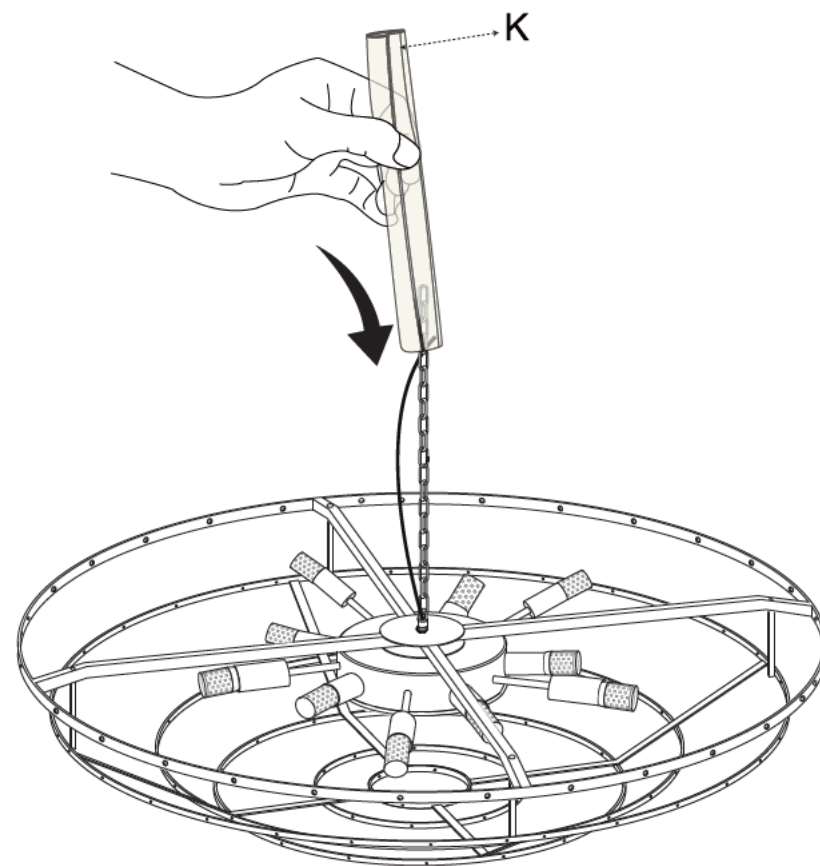

- ▶ Connected the G2 chain to G1 as shown, freely installed the length
- ▶ "Zubehör G" wird wie in der Abbildung gezeigt angeschlossen, die Länge ist einstellbar
- ▶ 上図のように、チェーンGの長さを調節することができます
- ▶ Connectez la chaîne 'pièce G' comme indiqué sur l'image, vous pouvez régler la longueur selon vos besoins.
- ▶ 쇠사슬 '액세서리 G'는 그림과 같이 연결되며, 길이는 필요한대로 부착할 수 있습니다.

7

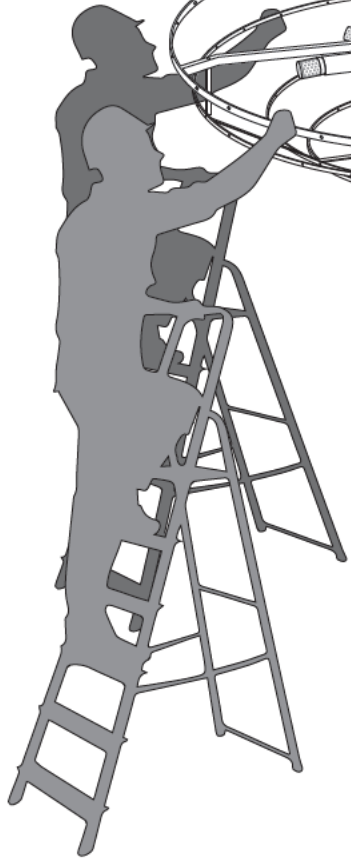
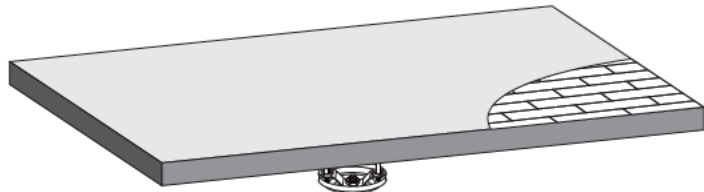

- ▶ Strong recommended that two people for assembly, attached the assembled part to the Part A on the wall
- ▶ Verbinden Sie bitte zuerst das FertigInstallation mit dem Wandteil, vorzugsweise arbeiten zwei Personen zusammen
- ▶ フレームを天井にあった部品Eに繋いでください。
(注意：2人で作業してください)
- ▶ Reliez d'abord la partie installée à la partie murale, Il est recommandé que deux personnes l'installent
- ▶ 설치 부분을 벽 부분과 먼저 연동하여 두 사람이 같이 설치하는 것이 좋습니다.

8

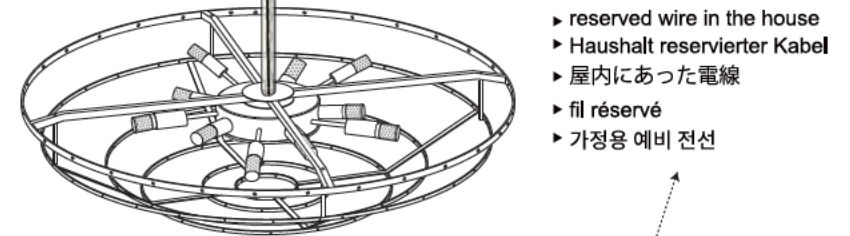
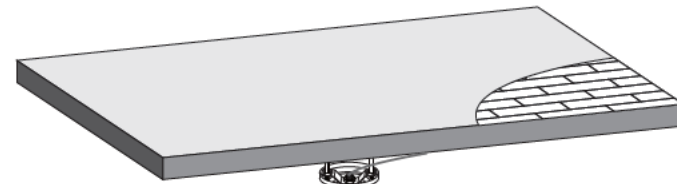

- ▶ reserved wire in the house
- ▶ Haushalt reservierter Kabel
- ▶ 屋内にあった電線
- ▶ fil réservé
- ▶ 가정용 예비 전선

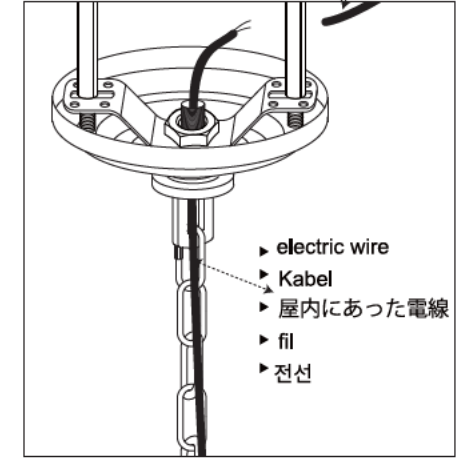
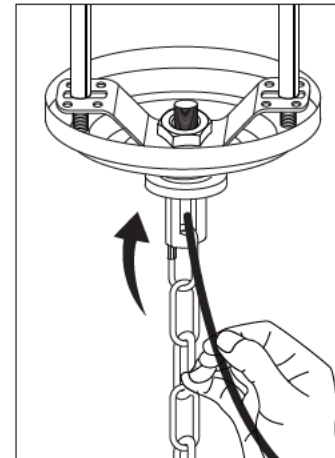

- ▶ Electric wire run through the Part E, connected with the wire in the house
- ▶ Das Kabel wird durch das E-Loch des Zubehörs geführt und mit dem für den Haushalt reservierten Kabel verbunden
- ▶ 照明の電源コードを配件Eに通してから、屋内にあった電線に繋がます
- ▶ Passez le fil par le trou de la pièce E et le connectez au fil réservé.
- ▶ 전선은 부속품 E의 구멍으로 통과하여 집에 남겨둔 전선과 연결됩니다.

9

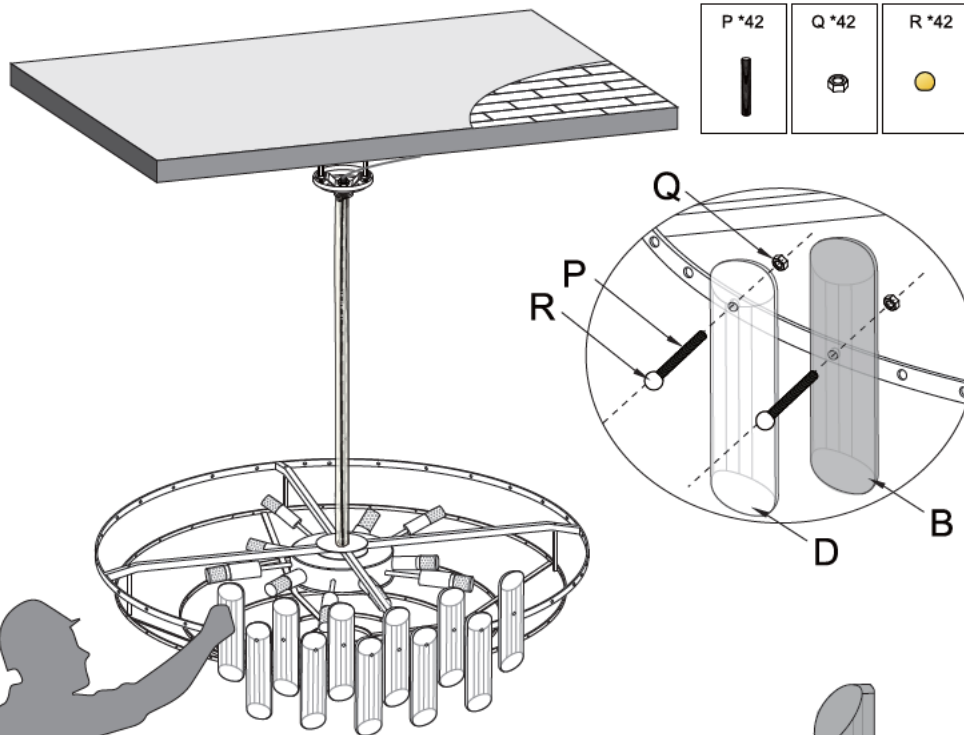

P *42

Q *42

R *42



- ▶ Make the bevel of large crystal outward, stagger to install
- ▶ D und B werden abwechselnd installiert, wobei die abgeschnittene Seite nach außen zeigt
- ▶ 注意：1つの部品Bを留め、次いで1つの部品Dを留めるという順に留めていってください
- ▶ La face inclinée des cristaux est tournée vers l'extérieur.
- ▶ 큰 크리스탈 경사면이 밖으로 향하여 엇갈리게 설치하십시오.

- ▶ Get a ladder, fix the large crystals with screws
- ▶ Befestigen Sie bitte mit Hilfe einer Leiter zuerst den großen Kristall mit Schrauben auf dem Regal
- ▶ 脚立を利用して部品Bと部品Dを高めのリングに留めます
- ▶ Préparez l'échelle et fixez d'abord les grands cristaux sur le cadre avec des vis
- ▶ 사다리를 준비하고, 큰 수정은 나사로 선반에 먼저 고정하십시오.

10



S *130

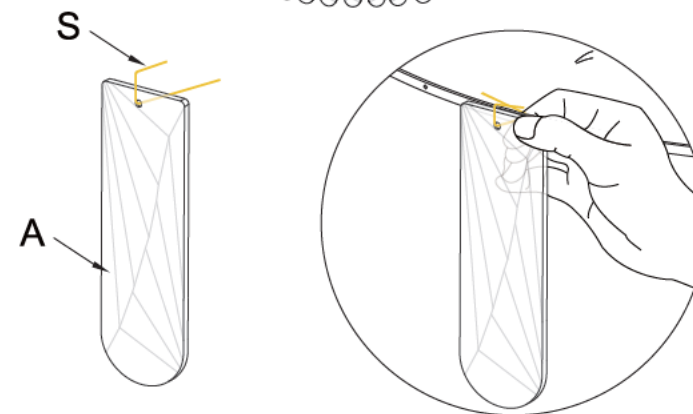

- ▶ Fix the small crystals to the steel frame with Part S as shown
- ▶ Befestigen Sie bitte den kleinen Kristall wie abgebildet am Eisenrahmen
- ▶ 上図のように、部品Aを低めのリングに留めます
- ▶ Fixez les petits cristaux au cadre en acier comme indiqué
- ▶ 그림에 따라 작은 크리스탈을 철골에 고정하십시오.