

## Recommended Maximum Weight

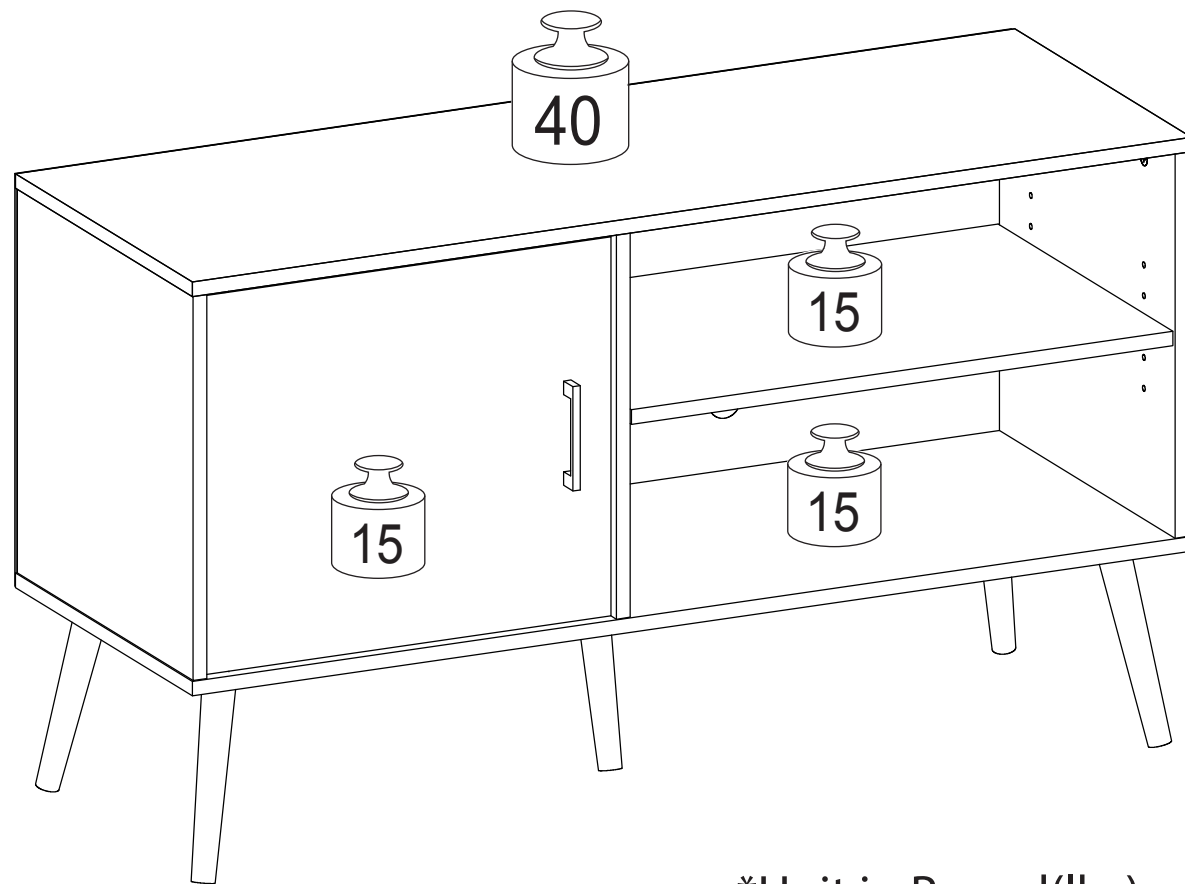

\*Unit in Pound(lbs)

### **WARNING:**

>This unit has been designed to support the maximum loads shown. Exceeding these load limits could cause sagging, instability, product collapse, and/or serious injury.

>DO NOT allow children to climb on unit.

> Put heavier items on lower shelves.

00:20

Approx. 20 minutes



Recomm. 2 Persons

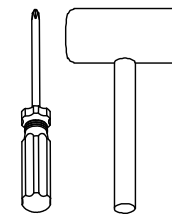





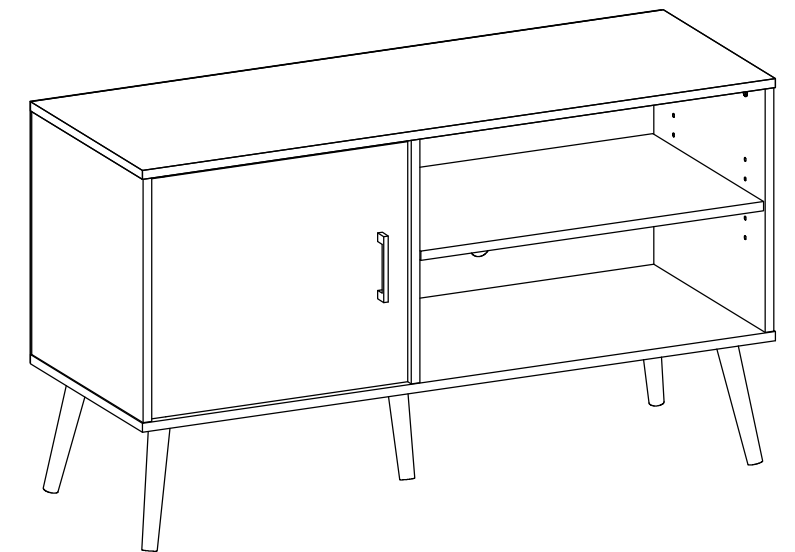

Tool Required

## **Assembly Instruction**

TV Stand with Wood Leg ,One Cabinet  
Two Shelves.



# HARDWARE & PARTS LIST

NO	HARDWARE LIST	QTY
1	MINIFIX  	6sets
2	LONG SCREW 	6pcs
3	DOWEL 	12pcs
4	SHELF SUPPORT 	4pcs
5	POWER PIN 	24pcs
6	HANDLE 	1pc
7	HANDLE SCREW 	2pcs
8	DOOR SPRING 	2pcs
9	MAGNET 	1pc
10	FLAT HEAD SCREW 	1pc
11	WOODEN LEG 	5pcs
12	METAL SUPPORT PLATE 	5pcs
13	SHORT SCREW 	25pcs

NO	PARTS LIST	QTY
A	TOP PANEL	1pc
B	LEFT SIDE PANEL	1pc
C	RIGHT SIDE PANEL	1pc
D	CENTER PANEL	1pc
E	BOTTOM PANEL	1pc
F	ADJUSTABLE SHELF PANEL	1pc
G	DOOR PANEL	1pc
H	BACK PANEL	1pc

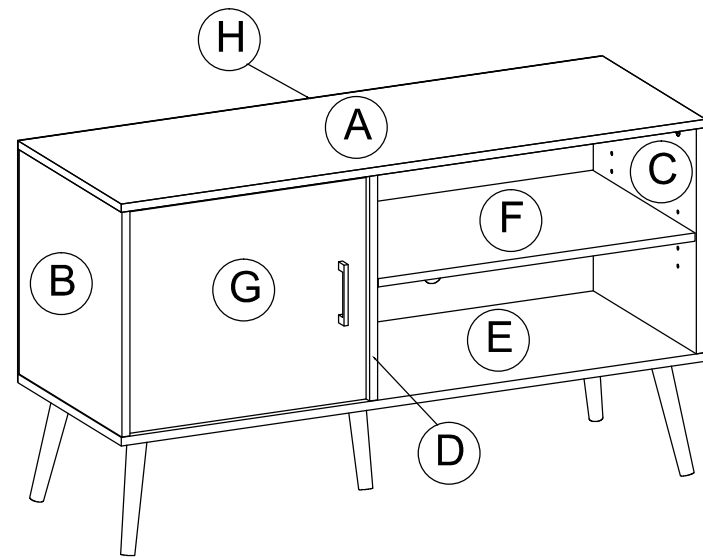

## STEP 7

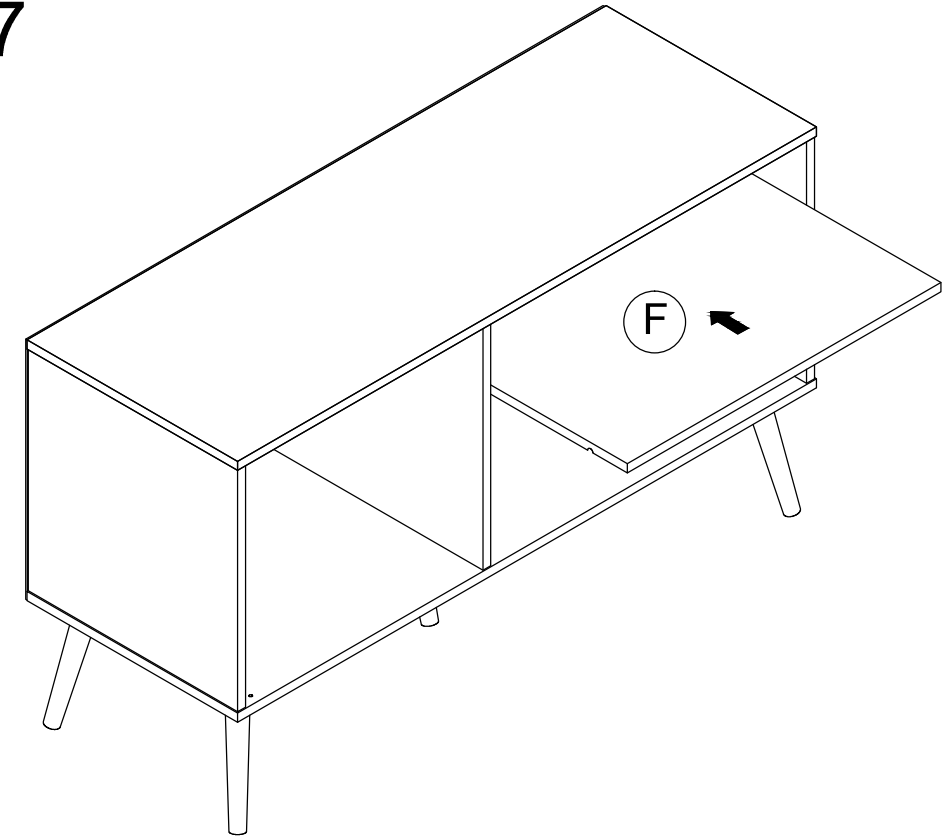

## STEP 8

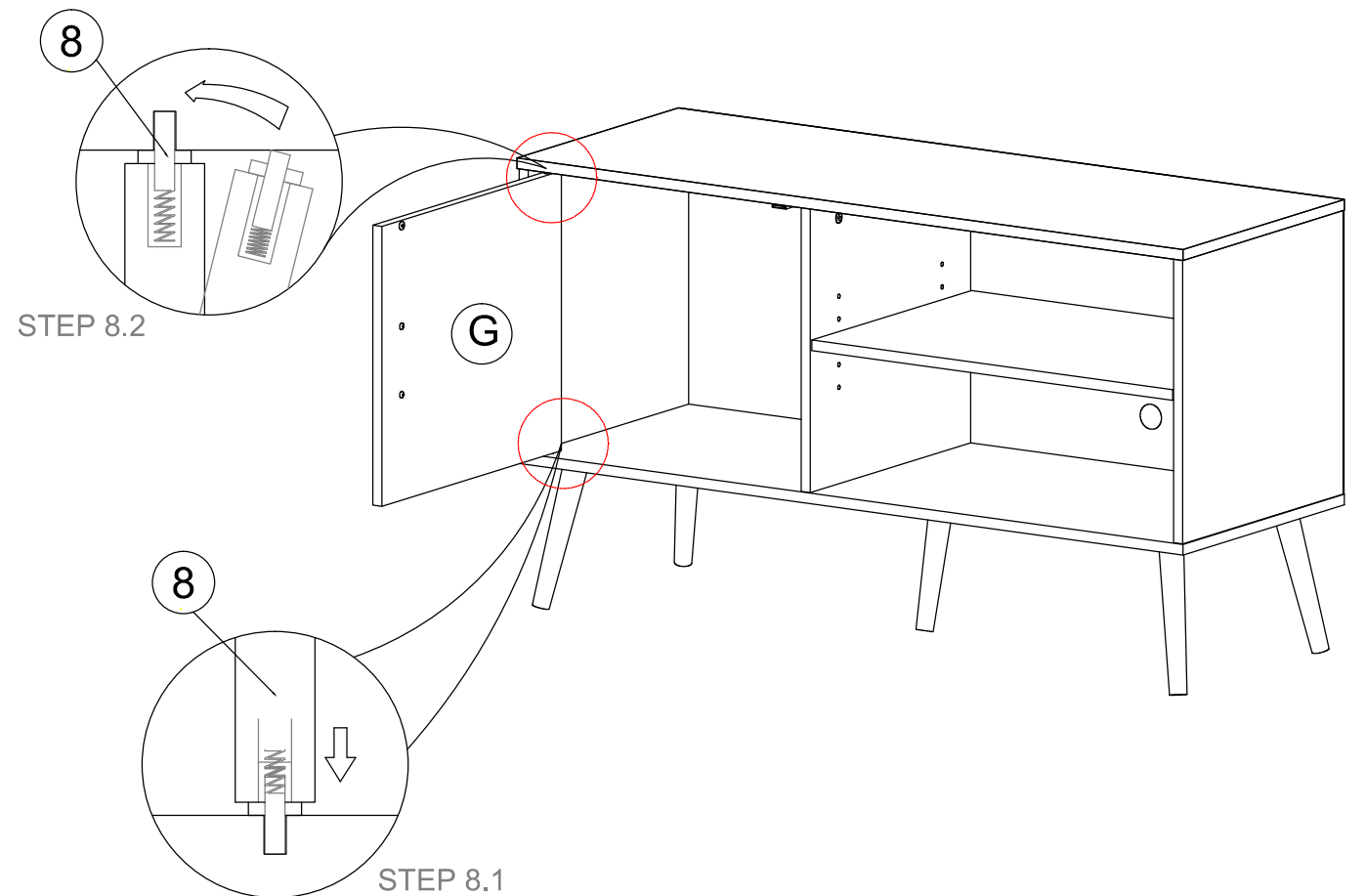

### USEFUL HINTS BEFORE YOU START:

1. Read each step carefully before starting.
2. It is important that each step is performed in correct order to avoid difficulties.
3. Identify, sort and count the parts before assembly.
4. Assemble your furniture on packaging cardboard to prevent scratch or damage.
5. Clean the product with mild cleanser using soft damped cloth. Do not use harsh or abrasive cleanser.
6. Using incompatible hardware might cause damage to product.

# STEP 6

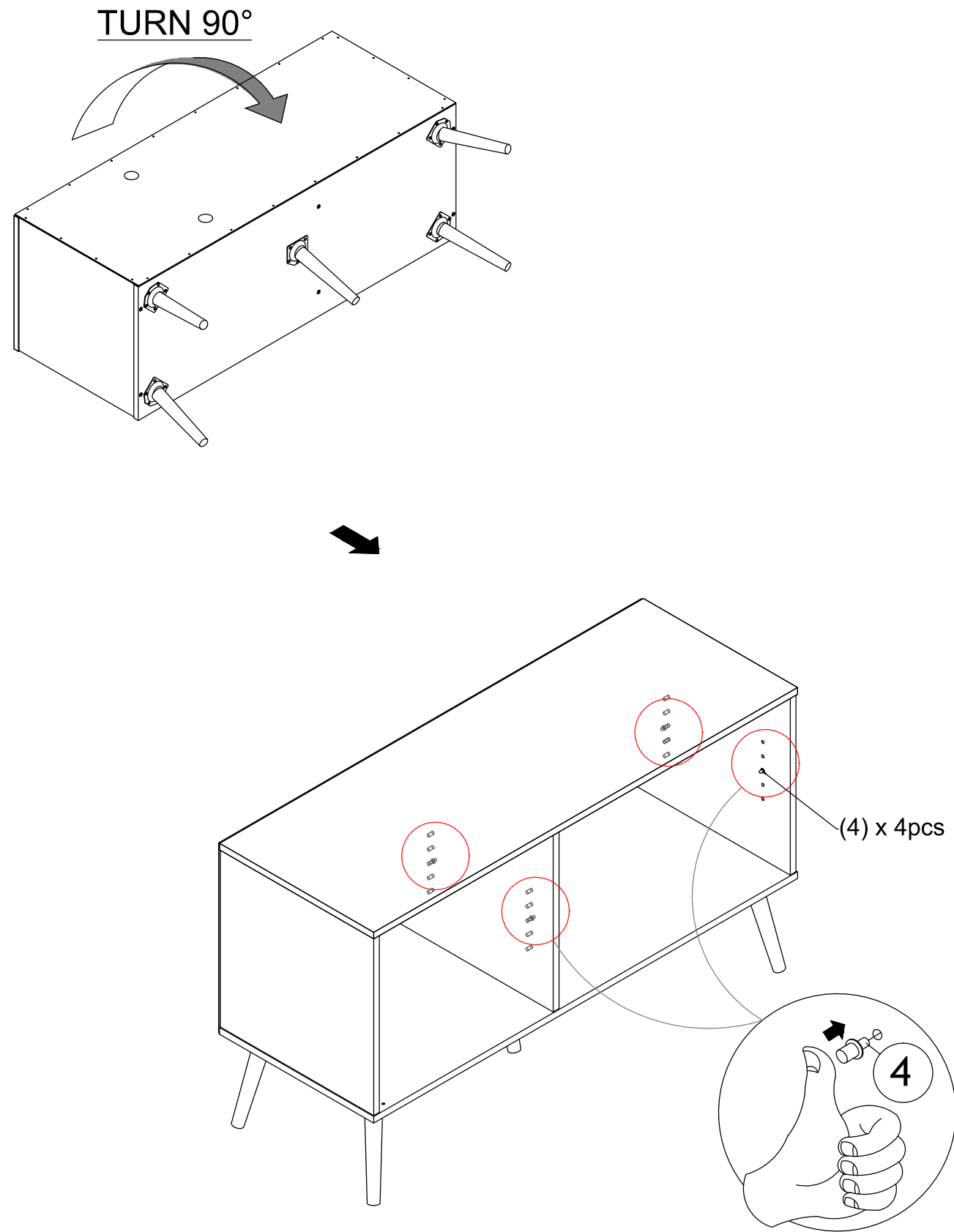

# ASSEMBLY INSTRUCTIONS

BEFORE YOU BEGIN, PLEASE READ ASSEMBLY INSTRUCTIONS CAREFULLY, FOLLOW THEM STEP BY STEP.

## STEP 1

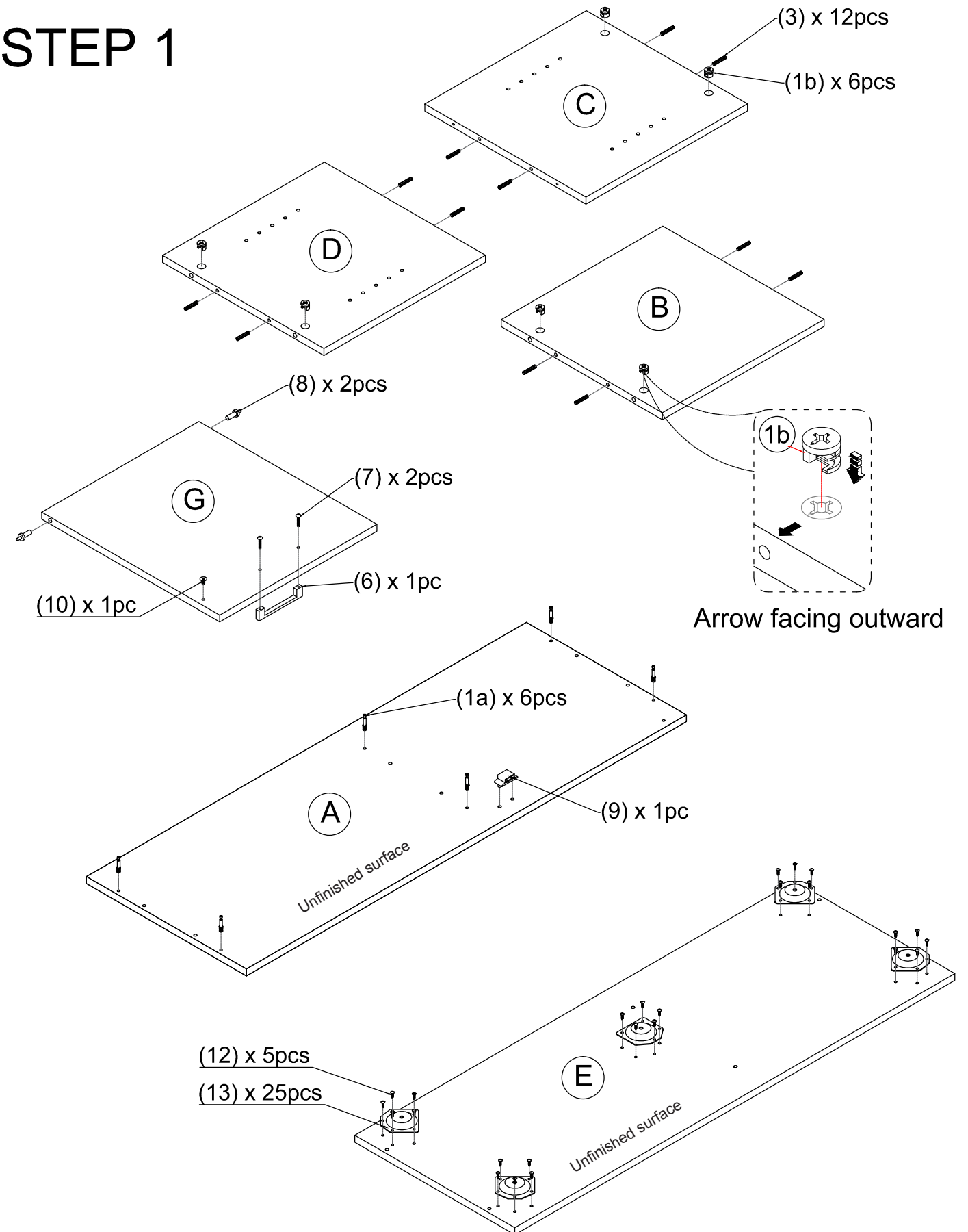

# STEP 2

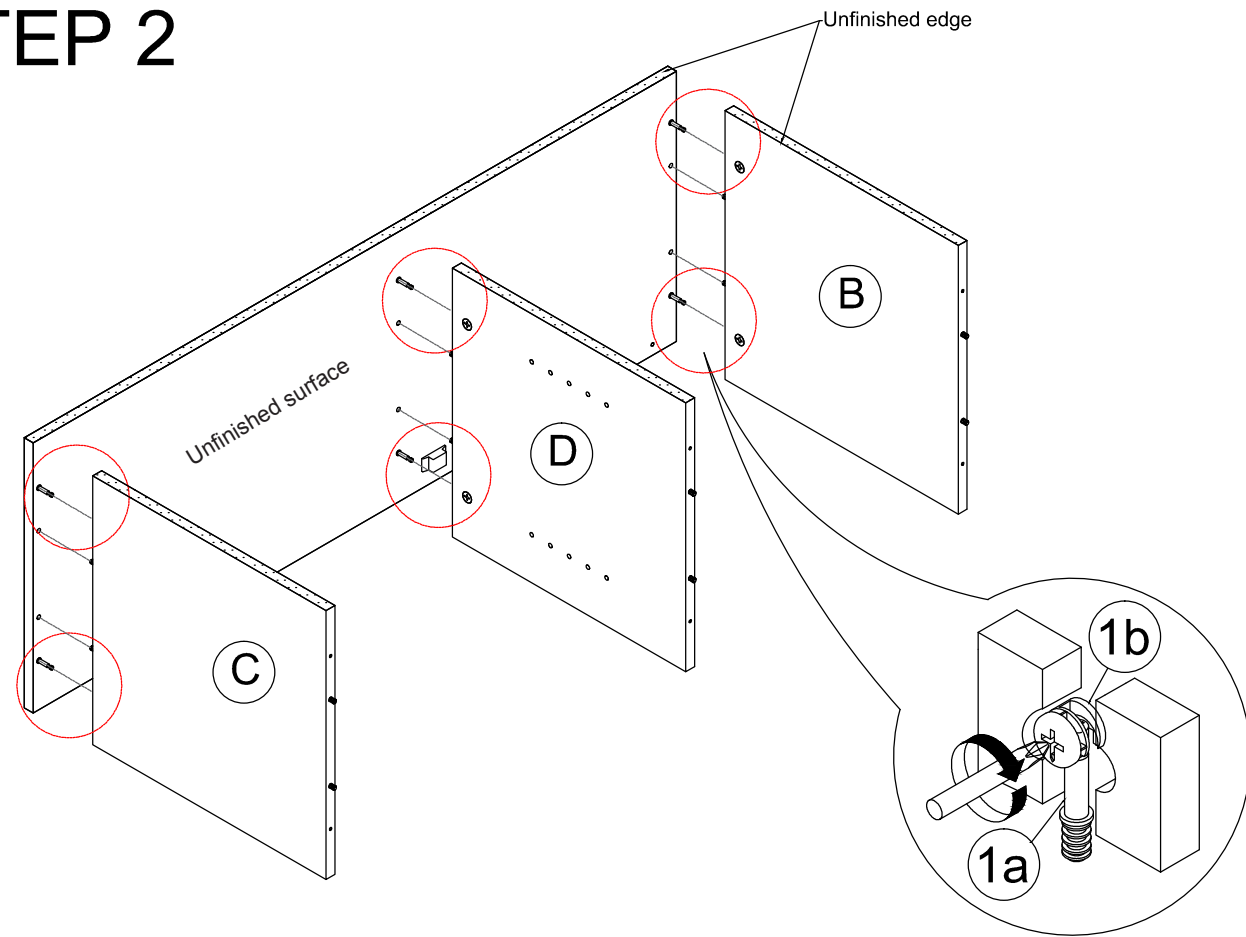

# STEP 4

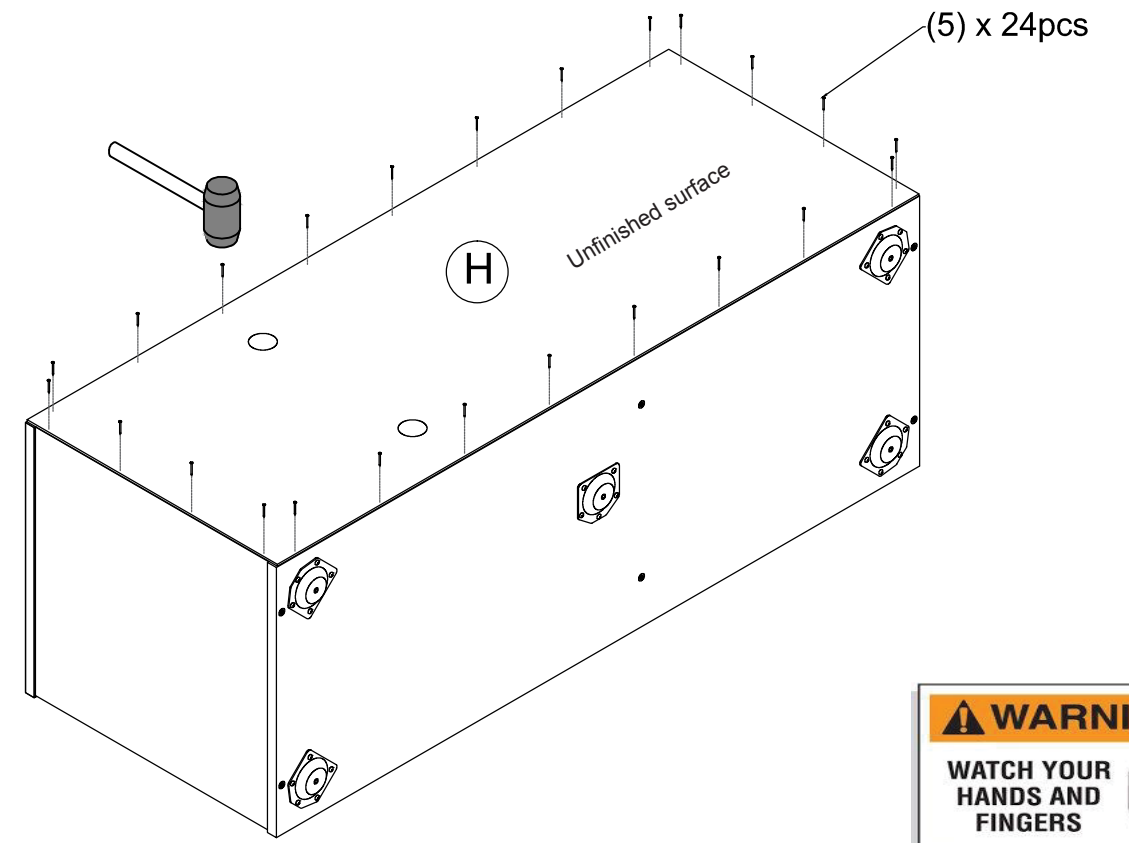

# STEP 3

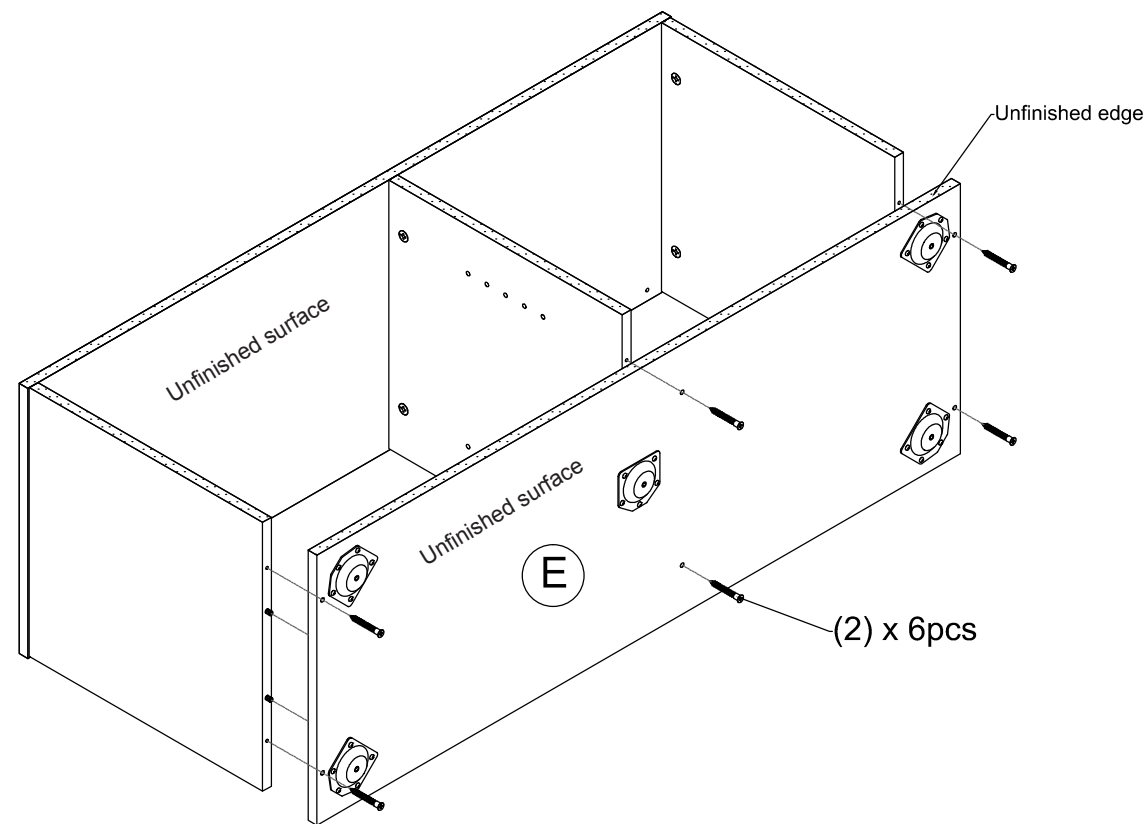

# STEP 5

