



# WINDOW AIR CONDITIONER

## USER MANUAL

FOR MODEL:

**3PACH8000**  
WITH ELECTRIC HEAT

**3PACH12000**  
WITH ELECTRIC HEAT



Before using your air conditioner, please read this manual carefully and keep it for future reference, along with your receipt.

# CONSUMER PRODUCT INFORMATION

---

For your own records, please attach a copy of your sales receipt to this manual and complete the following:

Model Number: \_\_\_\_\_ Serial Number: \_\_\_\_\_

Purchase Date: \_\_\_\_\_ Store Purchased: \_\_\_\_\_

Installation Date: \_\_\_\_\_ Installation Co.: \_\_\_\_\_

Installer Name: \_\_\_\_\_ Installer Phone No.: \_\_\_\_\_

# CONTENTS

---

SAFETY PRECAUTIONS.....	1
IMPORTANT SAFETY INSTRUCTIONS.....	3
INSTALLATION INSTRUCTIONS.....	4
NORMAL SOUNDS.....	9
AIR CONDITIONER FEATURES.....	19
CARE AND CLEANING.....	12
TROUBLESHOOTING.....	13

This manual provides the information needed for proper use and maintenance of this air conditioner. Basic preventative care can help extend the life of this unit. The “Troubleshooting” section in this manual contains a chart with solutions to the most common problems. Referring to this section may save time and prevent the need for a service call in the event of a problem.

## CAUTIONS

- Contact an authorized service technician for repair or maintenance of this unit.
- Contact an installer for installation of this unit if necessary.
- The air conditioner is not intended for use by young children without adult supervision. Young children should be supervised to ensure that they do not play with the air conditioner.
- Disabled persons may require assistance with set up.
- If the power cord is to be replaced, replacement work should be performed by authorized personnel only.
- Installation and repair work must be performed in accordance with the national wiring standards by authorized personnel only.
- Do not operate your air conditioner in a wet room such as a bathroom or laundry room.

**NOTE:** All the illustrations in this manual are for explanation purposes only. Unit purchased may be slightly different.

The design and specifications are subject to change without prior notice for product improvement. Contact Consumer Services at 844-472-2473 for details.

# SAFETY PRECAUTIONS

## READ SAFETY PRECAUTIONS BEFORE INSTALLATION

To prevent injury to the user or other people and property damage, the following instructions must be followed. Incorrect operation due to ignoring of instructions may cause harm or damage. The seriousness is classified by the following indications.



**THIS SYMBOL INDICATES THAT IGNORING INSTRUCTIONS MAY CAUSE DEATH OR SERIOUS INJURY.**



**THIS SYMBOL INDICATES THAT IGNORING INSTRUCTIONS MAY CAUSE MODERATE INJURY TO YOUR PERSON, OR DAMAGE TO YOUR UNIT OR OTHER PROPERTY.**

**OTHER SYMBOLS:**

















**NEVER DO THIS.**

**ALWAYS DO THIS.**

## **WARNINGS**

Plug in power cord properly.	Failure to do so may cause electric shock or fire due to excess heat generation.
<b>DO NOT</b> operate or stop the unit by inserting or pulling out the power plug directly from the wall.	Doing so may cause electric shock or fire due to heat generation.
<b>DO NOT</b> use a damaged power cord.	Doing so may cause electric shock or fire. If the power cord is damaged, it must be replaced by the manufacturer or an authorized service center or a similarly qualified person in order to avoid a hazard.
<b>DO NOT</b> modify power cord length or share the outlet with other appliances.	Doing so may cause electric shock or fire due to heat generation.
<b>DO NOT</b> operate with wet hands or in damp environment.	Doing so may cause electric shock.
<b>DO NOT</b> direct airflow directly at room occupants.	This could cause health issues.
Always ensure effective grounding.	Incorrect grounding may cause electric shock.
<b>DO NOT</b> allow water to run into electric parts.	Doing so may cause failure of machine or electric shock.
Always install circuit breaker and a dedicated power circuit.	Incorrect installation may cause fire and electric shock.
Always unplug the unit if strange sounds, smell or smoke comes from the unit.	Failure to do so may cause fire and electric shock.
<b>DO NOT</b> use the socket if it is loose or damaged.	Doing so may cause fire and electric shock.
<b>DO NOT</b> open the unit during operation.	Doing so may cause electric shock.
<b>DO NOT</b> use firearms near unit.	Doing so may cause fire.
<b>DO NOT</b> use the power cord close to heating appliances.	Doing so may cause fire and electric shock.
<b>DO NOT</b> disassemble, modify, or drill holes into the air conditioner.	Doing so may cause failure and electric shock and void the manufacturer's warranty.
Ventilate room before operating air conditioner if there is a gas leak from another appliance such as a stove.	Failure to do so may cause explosion, fire and burns.
<b>DO NOT</b> use the power cord near flammable gas or combustibles, such as gasoline, benzene, thinner, etc.	Doing so may cause an explosion or fire.

## CAUTIONS

 When removing air filter, <b>DO NOT</b> touch metal parts of the unit.	Doing so may cause an injury.
 <b>DO NOT</b> clean with water.	Water may enter the unit and degrade the insulation, causing an electric shock.
 Ensure proper ventilation, especially in rooms with a stove or other appliances.	Failure to do so may result in an oxygen shortage.
 Unit and circuit breaker/fuse must be switched OFF when cleaning.	Cleaning unit when power is ON may cause fire and electric shock and may cause an injury.
 <b>DO NOT</b> put a pet or house plant where it will be exposed to direct air flow.	This could injure the pet or plant.
 Use <b>ONLY</b> as intended.	This unit is <b>NOT</b> intended to preserve precision devices, food, pets, plants, and art objects. It may cause deterioration of quality, etc.
 Stop operation and close the window in severe storms or hurricanes.	Operation with windows open may cause moisture to enter the room.
 Hold the plug by the head of the power plug when taking it out.	Failure to do so may cause electric shock and damage.
 If unit will not be used for a long period of time, unplug or turn <b>OFF</b> main power switch.	Leaving power on may cause unit failure or fire.
 <b>DO NOT</b> place obstacles around air-inlets or inside of air-outlet.	Obstacles may cause appliance failure or accident.
 Periodically check installation bracket for damage.	Prolonged exposure to outdoor elements may cause damage to installation bracket, causing unit to fall.
 Always insert filter(s) securely. Clean filter(s) <b>AT LEAST</b> once every two weeks.	Operation without securely installed filters may cause failure. A dirty filter can cause the unit to not run efficiently.
 Use only a soft cloth to clean the unit.	Cleaners or detergents may change the color or scratch the surface of the unit.
 Use caution when unpacking and installing.	Sharp edges could cause injury.
 <b>NEVER</b> drink water drained from air conditioner.	Water from unit contains contaminants and could cause illness.
 <b>DO NOT</b> place heavy objects on the power cord and always ensure that the cord is not compressed.	There is danger of fire or electric shock.
 If water enters the unit's electrical components, turn the unit off at the power outlet and switch off the circuit breaker. Isolate supply by taking the power-plug out and contact a qualified serviced technician.	There is danger of electric shock.

# IMPORTANT SAFETY INSTRUCTIONS

## NOTE:

The power supply cord with this air conditioner contains a current detection device designed to reduce the risk of fire. Please refer to the section "Operation of Current Device" (below) for details. In the event that the power supply cord is damaged, it cannot be repaired. It must be replaced by an authorized repair technician with a cord from the Product Manufacturer.

## WARNING

Avoid fire hazards or electric shock. **DO NOT** use an extension cord or an adapter plug. **DO NOT** remove any prong from the power cord.

Grounding Type  
Wall Receptacle

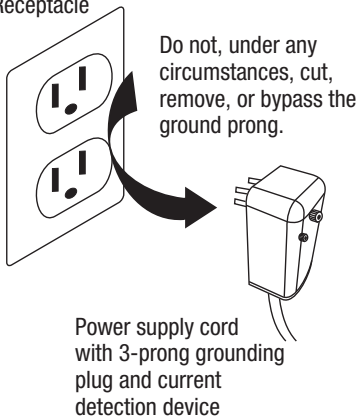

## OPERATION OF CURRENT DEVICE:

The power supply cord contains a current device that senses damage to the power cord. To test your power supply cord, do the following:

1. Plug in the air conditioner.
2. The power supply cord will have TWO buttons on the plug head. Press the TEST button. You will notice a click as the RESET button pops out.
3. Press the RESET button. Again, you will notice a click as the button engages.
4. The power supply cord is now supplying electricity to the unit. (On some products this is also indicated by a light on the plug head.)

## WARNING

FOR YOUR SAFETY: Do not store or use gasoline or other flammable vapors and liquids in the vicinity of this or any other appliances.

## WARNING - PREVENT ACCIDENTS

To reduce the risk of fire, electrical shock, or injury to persons when using your air conditioner, follow basic precautions, including the following:

- Be sure the electrical service is adequate for the model you have chosen. This information can be found on the serial plate, which is located on the side of the cabinet and behind the grille.
- If the air conditioner is to be installed in a window, you will probably want to clean both sides of the glass first. If the window is a triple-track type with a screen panel included, remove the screen completely before installation.
- Be sure the air conditioner has been securely and correctly installed according to the installation instructions in this manual.
- Save this manual for possible future use in removing or installing this unit.
- When handling the air conditioner, be careful to avoid cuts from sharp metal fins on front and rear coils.

## WARNING - ELECTRICAL INFORMATION

The complete electrical rating of your new room air conditioner is stated on the serial plate. Refer to the rating when checking the electrical requirements.

- Be sure the air conditioner is properly grounded. To minimize shock and fire hazards, proper grounding is important. The power cord is equipped with a three-prong grounding plug for protection against shock hazards.
- Your air conditioner must be used in a properly grounded wall receptacle. If the wall receptacle you intend to use is not adequately grounded or protected by a time delay fuse or circuit breaker, have a qualified electrician install the proper receptacle.
- Ensure the receptacle is accessible after the unit installation.
- **DO NOT** run air conditioner without side protective cover in place. This could result in mechanical damage within the air conditioner.
- **DO NOT** use an extension cord or an adapter plug.

## NOTE:

**DO NOT** use the plug to turn the unit on or off.

- Always make sure the RESET button is pushed in for correct operation.
- The power supply must be replaced if it fails reset when either the TEST button is pushed or it cannot be reset.
- If power supply cord is damaged, it cannot be repaired. Please call Consumer Services at 844-472-2473 to assist with replacement.

**NOTE:** This air conditioner is designed to be operated under the following conditions:

Cooling Operation	<b>Outdoor Temp:</b>	64–109°F/18–43°C (64–125°F/18–52°C for special tropical models)
	<b>Indoor Temp:</b>	62–90°F/17–32°C
Heating Operation	<b>Outdoor Temp:</b>	23–76°F/-5–24°C
	<b>Indoor Temp:</b>	32–80°F/0–27°C

Performance may be reduced outside of these operating temperatures.

# INSTALLATION INSTRUCTIONS

## **STOP** BEFORE YOU BEGIN

Read these instructions completely and carefully.

**IMPORTANT-** Save these instructions.

**IMPORTANT-** Observe all governing codes and ordinances.

**Note to Installer-** Be sure to leave these instructions with the Consumer.

**Note to Consumer-** Keep these instructions for future reference.

**Skill level-** Installation of this appliance requires basic mechanical skills.

**Completion time-** Approximately 1 – 1½ hours.

We recommend that two people install this product.

Proper installation is the responsibility of the installer.

Product failure due to improper installation is not covered under the Warranty.

You **MUST** use all supplied parts and use proper installation procedures as described in these instructions when installing this air conditioner.

## **!** CAUTION

**DO NOT**, under any circumstances, cut or remove the third (ground) prong from the power cord.

**DO NOT** change the plug on the power cord of the air conditioner.

Aluminum house wiring may present special problems-consult a qualified electrician.

When handling unit, be careful to avoid cuts from sharp metal edges and aluminum fins on front and rear coils.

To avoid risk of personal injury, property damage, or product damage due to the weight of this unit and sharp edges that may be exposed, please note the following:









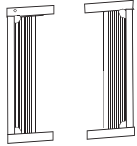
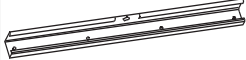

- Air conditioners covered in this manual pose an excessive weight hazard. Two or more people are needed to move and install the unit. To prevent injury or strain, use proper lifting and carrying techniques when moving unit.
- Carefully inspect location where air conditioner will be installed. Be sure it will support the weight of the unit.
- Handle air conditioner with care. Wear protective gloves whenever lifting or carrying the unit. **AVOID** the sharp metal fins of front and rear coils.
- Use extra caution to ensure that air conditioner does not fall during installation.

## REQUIRED TOOLS/HARDWARE

Gather the required tools and parts before starting installation. Read and follow the instructions provided with any tools listed here:

- Phillips screwdriver
- Flat blade screwdriver
- Drill and 3/16", 1/8", 3/32" or smaller drill bit
- Level
- Tape measure
- Pencil

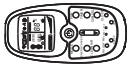
Check that all the parts listed below are included in the parts package.

HARDWARE		
PICTURE	DESCRIPTION	QTY
	#10 x 1/2" Pan-Head Phillips Screws	3
	#10 x 3/4" or #10 x 1/2" Round-Head Screws	7
	#10 x 1/4" Pan-Head Phillips Screws	5
	Accordion Panels	2
	Top Channel	1
	Window Sash Seal	1
	Foam Seal	1
	Window Lock Bracket	1
	Safety Lock (for vinyl-clad window)	2
	Weather Seals (6" x 3/4" x 1/12")	5
	Remote Control	1
	Remote Control Batteries	2

## **!** NOTES:

- Installation parts are supplied for double-hung windows up to 36" (91.4 cm) wide.
- **DO NOT** use any screws other than those specified here.
- **DO NOT** use an extension cord.
- Cabinet louvers must not be obstructed. Air must be able to pass freely through the cabinet louvers. (Fig. 1 on next page)



FIG. 1

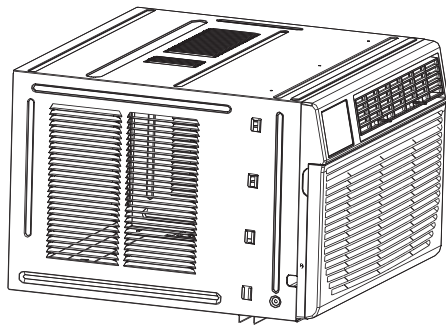

## LOCATION REQUIREMENTS:

**IMPORTANT:** Observe all governing codes and ordinances. Check the location where the air conditioner will be installed. Proper installation is your responsibility. Make sure you have everything necessary for proper installation.

- Ground electrical outlet within 4 ft. (122 cm) of where the power cord exits the air conditioner.
- There must be free movement of air in the room to be cooled.
- A large enough opening for the air conditioner must exist.
- It is necessary to have adequate wall support for the weight of the air conditioner. The unit weighs between 70 and 85 lbs (32 to 40 kgs).

WINDOW OPENING MEASUREMENT (Fig. 2):

- 26 $\frac{7}{8}$ " to 36" (68.3 cm to 91.4 cm) opening width
- 16 $\frac{1}{2}$ " (41.9 cm) minimum opening height

FIG. 2

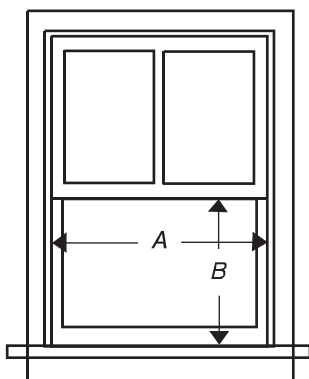

- A. 26 $\frac{7}{8}$  in. (68.3 cm) minimum
- B. 16 $\frac{1}{2}$  in. (41.9 cm) minimum

## ► STEP 1: REMOVE PACKAGING MATERIAL

- Remove and dispose of or recycle packaging materials. Remove tape and glue residue from surfaces before installing the air conditioner. Rub a small amount of liquid soap over the adhesive with your fingers. Wipe with warm water and dry.
- Do not use sharp instruments, rubbing alcohol, flammable fluids, or abrasive cleaners to remove tape or glue. These products can damage the surface of your air conditioner.

- Handle the air conditioner gently:
  1. Remove the air conditioner from the carton and place it on cardboard.
  2. Remove shipping screw (A) from each side of the cabinet. (Fig. 3)

FIG. 3

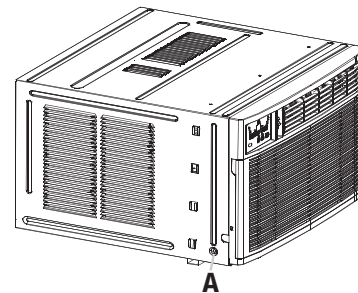

3. Remove front panel by removing one Phillips screw (B) from each side of the front panel. Set screws aside and save. (Fig. 4)

FIG. 4

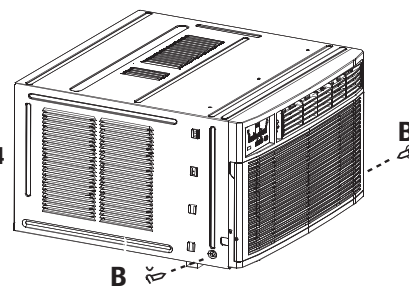

4. Pull on the handle (C) to slide the air conditioner out of the cabinet. Place the air conditioner on cardboard. (Fig. 5)

FIG. 5

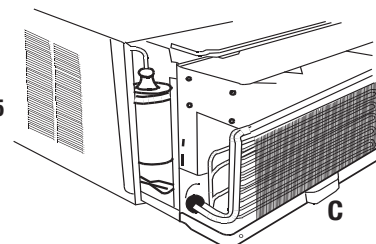

## ⚠ NOTES:

- Handle the air conditioner gently.
- Be sure your air conditioner cabinet does not fall out of the opening during installation or removal.
- The air conditioner should be no more than 4 ft (122 cm) from a grounded 3 prong outlet.
- Do not block the louvers on the front panel.
- Do not block the louvers on the outside of the air conditioner.
- **DO NOT lift, pull, or remove any expanded polystyrene (foam) from inside of the air conditioner. It is NOT packing material.**



**▶ STEP 2:  
ATTACH TOP CHANNEL**

Attach the top channel and side curtains to the air conditioner cabinet before placing the cabinet in the window. (Fig. 6)

1. Locate provided bag of screws.
2. Place the top channel on top of the air conditioner cabinet, lining up the three holes in the top channel with the three holes on top of the air conditioner cabinet.
3. Using three #10 x 1/4" pan-head Phillips thread cutting screws, attach the top channel to the air conditioner cabinet.

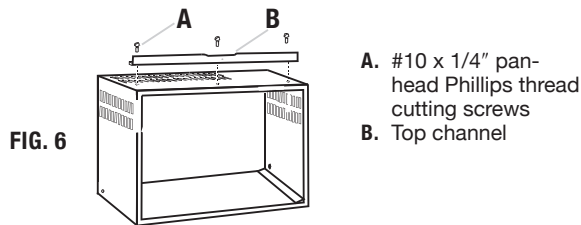

**▶ STEP 3:  
ATTACH ACCORDION PANELS**

1. Locate provided bag of screws.
2. Insert the right-hand accordion panel connector tab into the accordion panel housing channels on the air conditioner. (Fig 7A)

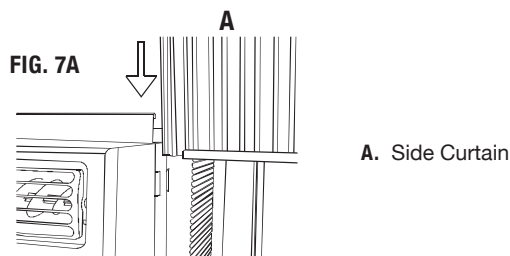

3. Insert the top and then bottom of the right-hand accordion panel housing in the top and bottom accordion panel channels on the air conditioner (Fig. 7B and Fig 7C)

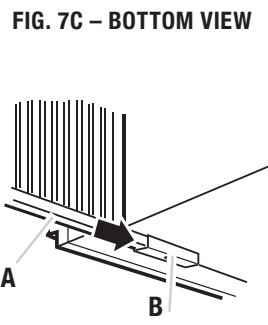
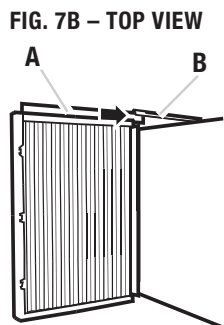

4. Slide the accordion panel housing into the accordion panel guides as far as it can go.
5. Repeat the above steps for the left-hand accordion panel.

**▶ STEP 4:  
ATTACH FOAM ADHESIVE SEAL**

Attach foam adhesive seal along the bottom of the accordion panel's bottom channel.

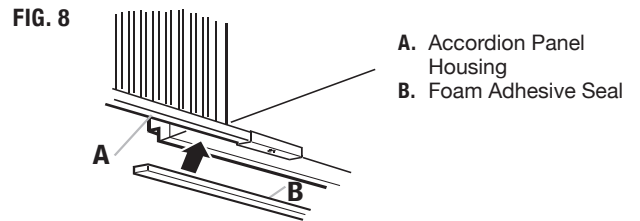

**▶ STEP 5:  
INSTALL CABINET INTO WINDOW**

1. Center empty cabinet in window:  
Check that lower rail of air conditioner cabinet is behind and against back side of window sill. Maintain a firm hold on the air conditioner cabinet (Fig. 9).

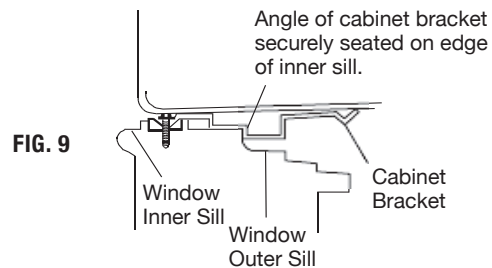

Lower window sash to hold the cabinet in place. Measure the distance between the right side of the cabinet and the inside of the window channel (Fig. 10).

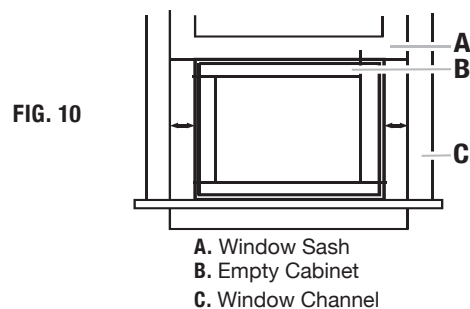

Repeat for the left side. Adjust the cabinet until the distance on each side is the same.

2. Attach the cabinet to the window:

**FOR WOODEN WINDOWS**

Use a 3/16" drill bit to drill three starter holes 3/8" deep through the three holes in the cabinet and into the window sill, and drill one starter hole 3/8" deep through the hole in the middle of top rail and into the window frame (Fig. 11). Attach cabinet to window with three #10 x 1/2" pan-head Phillips screws and one #10 x 3/4" or (1/2") round-head screw (Fig. 11).

**FOR VINYL-CLAD WINDOWS**

Use a 1/8" drill bit to drill one hole through the hole in the middle of top rail and into the window frame. Attach cabinet to window with one #10 x 3/4" or (1/2") round-head Phillips screw (Fig. 11). Place two safety locks into the holes located in the bottom of the cabinet as shown (Fig. 12).

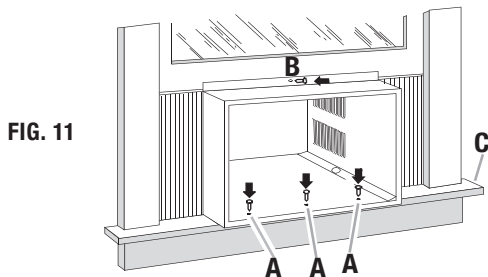

FIG. 11

- A. #10 x 1/2" pan-head Phillips screws
- B. #10 x 3/4" (or 1/2") round-head screw
- C. Window Channel

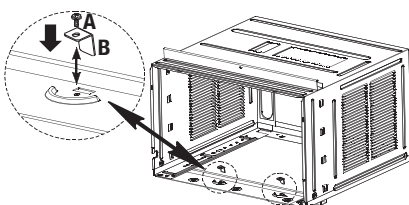

FIG. 12

- A. #10 x 1/4" pan-head Phillips screws
- B. Safety Lock (only for vinyl-clad windows)

3. Check that the air conditioner cabinet is tilted back to 1/8" to 1 1/2" (3~4°) so that water can run to the outside (Fig. 13).

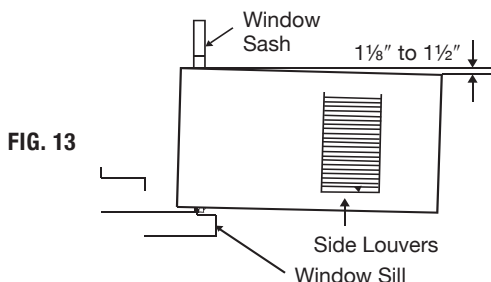

FIG. 13

**▶ STEP 6:  
ATTACH ACCORDION PANELS TO  
WINDOW FRAMES**

1. Extend the accordion panels out against the window frame (Fig. 11).
2. Drill holes and drive locking screws:

**FOR WOODEN WINDOWS**

Use a 3/32" drill bit to drill 4 starter holes through the holes in the side curtains into the window. Drive four #10 x 3/4" or (1/2") locking screws through the holes in the side curtains into the window sill and window frame (Fig. 14A, Fig. 14B).

**FOR VINYL-CLAD WINDOWS**

Use an 1/8" drill bit to drill two holes through the holes in the side curtains into the window frame as shown (Fig. 14A). Drive two #10 x 3/4" (or 1/2") locking screws through the holes in the side curtains into the window sash (Fig. 14A).

3. Trim the weather seal (6" x 3/4" x 1/12") with proper length, peel off the protective backing and plug any gaps if needed.

FIG. 14A

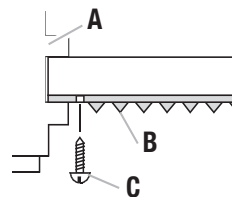

- A. Window channel
- B. Left-hand accordion panel
- C. #10 x 3/4" (or 1/2") round-head screw

FIG. 14B

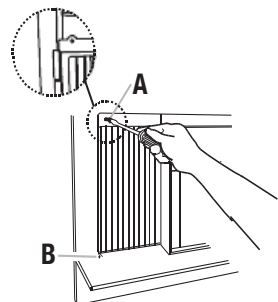

- A. #10 x 3/4" (or 1/2") round-head screw
- B. Slotted hole in the bottom of the accordion panel

**► STEP 7:  
COMPLETE INSTALLATION**

1. Insert window sash seal behind the top of the lower window sash and against the glass of the upper window (Fig. 15).
2. Place the window-lock bracket on top of lower window and against upper window sash on right side of the window (Fig. 15).
3. Use a 3/32" drill bit to drill starter holes through the holes in the bracket into the window sash (Fig. 15).
4. Attach the window lock-bracket to the window sash with two #10 x 3/4" or (1/2") round-head screws to secure window in place (Fig. 15).

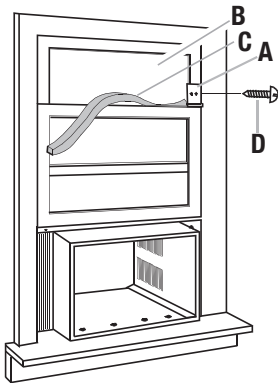

**FIG. 15**

- A. Window lock bracket
- B. Upper window glass
- C. Window sash seal
- D. #10 x 3/4" (or 1/2") round-head screws

5. Insert air conditioner into cabinet (Fig. 16).

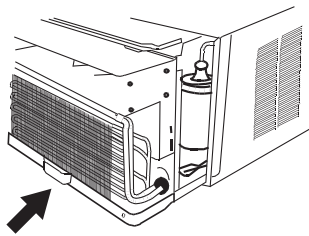

**FIG. 16**

6. Insert front tabs of front panel into top of cabinet and swing front into place.
7. Attach bottom front of panel with front panel screws (Fig. 17).
8. Plug into a grounded 3 prong outlet.
9. Press RESET on the power supply cord.

**FIG. 17**

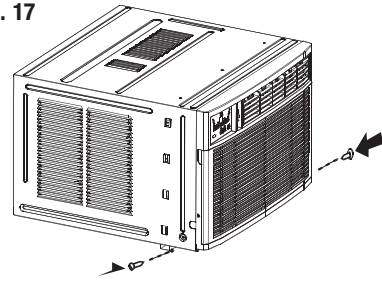

# NORMAL SOUNDS

**HIGH PITCHED CHATTER**  
High efficiency compressors may have a high pitched chatter during the cooling cycle.

**VIBRATION**  
Unit may vibrate and make noise because of poor wall or window construction or incorrect installation. This DOES NOT indicate a defective unit.

**PINGING OR SWITCHING**  
Droplets of water hitting condenser during normal operation may cause “pinging” or “switching” sounds.

**SOUND OF RUSHING AIR**  
At the front of the unit, the sound of rushing air being moved by the fan may be heard.

**GURGLE/HISS**  
“Gurgling” or “hissing” noise may be heard due to refrigerant passing through evaporator during normal operation.

**NOTE:** All of the pictures in this manual are for explanatory purposes only. The actual shape/look of the air conditioner purchased may be slightly different, but the operations and functions are similar.

# AIR CONDITIONER FEATURES

Thoroughly familiarize yourself with the control panel shown below and all of its functions. Afterwards, follow the symbol for the functions you desire BEFORE operating the unit. This unit can be controlled by the unit control or the remote control.

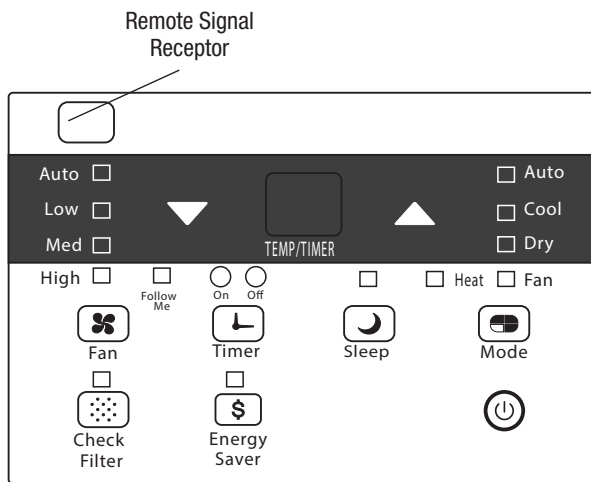

## UNIT CONTROL PANEL

Heat indicator on models with heating capabilities only.

### ▶ TO TURN UNIT ON OR OFF:

Press ON/OFF button to turn the unit on or off.

**NOTE:** The unit will automatically initiate the Energy Saver function under COOL, DRY and AUTO (only AUTO-COOLING and AUTO-FAN modes).

### ▶ TO CHANGE TEMPERATURE SETTING:

Press UP/DOWN buttons to change the temperature setting.

**NOTE:** Press or hold either UP () or DOWN () button until the desired temperature is shown on the display. The temperature will be automatically maintained anywhere between 62°F (17°C) and 86°F (30°C). If you want the display to read the actual room temperature, see “To Operate on Fan Only” section.

### ▶ TO ADJUST FAN SPEEDS:

Press to select the Fan Speed in four steps: Auto, Low, Med or High. Each time the button is pressed, the fan speed is shifted. In DRY mode, the fan speed is controlled at Low automatically. For some models with heating capabilities, the fan speed cannot be adjusted while in HEAT mode.

### ► SLEEP FEATURE:

Press the  SLEEP button to initiate the SLEEP mode. In this mode, the selected temperature will increase by 2°F (1°C) 30 minutes after the mode is selected. The temperature will then increase (cooling) or decrease (units with heating only) by another 2°F (1°C) after an additional 30 minutes. This new temperature will be maintained for 6 hours before it returns to the originally selected temperature. This ends the SLEEP mode and the unit will continue to operate as originally programmed. The SLEEP mode program can be canceled at any time during operation by pressing the SLEEP button again.

### ► CHECK FILTER FEATURE:

Press the  CHECK FILTER button to initiate this feature. This feature is a reminder to clean the Air Filter for more efficient operation. The LED (light) will illuminate after 250 hours of operation. To reset after cleaning the filter, press the CHECK FILTER button and the light will go off.

### ► ENERGY SAVER FEATURE:

Press the  ENERGY SAVER button to initiate this function. This function is available on COOL, DRY and AUTO (only AUTO-COOLING and AUTO-FAN) modes. In this mode, the fan will continue to run for 3 minutes after the compressor shuts off. The fan then cycles on for 2 minutes, at 10 minute intervals, until the room temperature is above the set temperature, at which time the compressor turns back on and cooling starts.

### ► FOLLOW ME FEATURE:

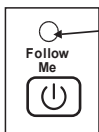

Light  
Flashing

**This feature can ONLY be activated from the remote control. The remote control serves as a remote thermostat allowing for precise temperature control at its location.**

To activate the Follow Me feature, point the remote control towards the unit and press the FOLLOW ME button. The remote displays the actual temperature at its location. The remote control will send this signal to the air conditioner every 3 minutes until the FOLLOW ME button is pressed again. If the unit does not receive the Follow Me signal during any 7 minute interval, the unit will beep to indicate use of the Follow Me feature has ended. The actual temperature can be displayed at the unit by pressing the FAN only mode. When in the COOL mode, the unit display indicates the set temperature.

### ► TO SELECT THE OPERATING MODE:

To choose operating mode, press the  MODE button. Each time you press the button, a mode is selected in a sequence that goes from AUTO, COOL, DRY, HEAT (for units with heating function) and FAN. The indicator light will be illuminated and remain on once the mode is selected. **The unit will automatically initiate the Energy Saver function under COOL, DRY, and AUTO (only AUTO-COOLING and AUTO-FAN) modes.**

#### TO OPERATE AUTO FEATURE:

When you set the air conditioner in AUTO mode, it will automatically select cooling, heating (on models with heating capabilities) or fan only operation depending on what temperature you have selected and the room temperature. The air conditioner will automatically control room temperature around the temperature you set. **In this mode, the fan speed cannot be adjusted.** It starts automatically at a speed according to the room temperature.

#### TO OPERATE FAN ONLY:

Use this function () only when cooling is not desired, such as for room air circulation or to exhaust stale air. (Remember to open the vent during this function, but keep it closed during cooling for maximum cooling efficiency.) You can choose any fan speed you prefer. During this function, the display will show the actual room temperature, not the set temperature as in the cooling mode.

#### TO OPERATE DRY MODE:

In this mode, the air conditioner will reduce air humidity. If the space is a closed or sealed area, some degree of cooling will continue.

### ► TIMER: AUTO START/STOP FEATURE:

- When the unit is on or off, press the  TIMER button. The TIMER ON indicator light illuminates. It indicates the Auto Start program has been initiated.
- When the time of TIMER ON is displayed, pressing the TIMER button again illuminates the TIMER OFF indicator light, indicating the Auto Stop program has been initiated.
- Press or hold the UP or DOWN buttons to change the Auto time by 0.5 hour increments, up to 10 hours, then by 1 hour increments, up to 24 hours. The control will count down the time remaining until start.
- The selected time will register in 5 seconds and the system will automatically revert back to displaying the previous temperature setting or the room temperature (depending on whether the unit is powered on or off and the mode it is in).
- Turning the unit ON or OFF at any time or adjusting the timer setting to 0.0 will cancel the Auto Start/Stop program.

**A NOTE ABOUT THE TIMER:** When you set the timer, the unit will only go on once and off once. If you want the air conditioner to cycle on and off based on desired room temperature, you do not need to set the timer. Instead, set your desired temperature and the unit will cycle on and off based on that temperature setting.

## ► DISPLAY:

Shows the set temperature in °F or °C and the Auto-timer settings. While on FAN only mode, it shows the room temperature.



## ERROR CODES:

**AS - Room Temperature Sensor Error** - Unplug the unit and plug it back in. If error repeats, call Consumer Services at 844-472-2473.

**HS - Electric Heating Sensor Error** - Unplug the unit and plug it back in. If error repeats, call Consumer Services at 844-472-2473.

• - **Evaporator Temperature Sensor Error** - Unplug the unit and plug it back in. If error repeats, call Consumer Services at 844-472-2473.

**NOTE:** If an error code occurs in FAN only mode, the unit will display “LO” (loose connection) or “HI” (short circuit).

## ↳ NOTE:

If the unit breaks off unexpectedly due to power being cut, it will automatically restart with the previous function setting when the power resumes.

## ► AIR DIRECTIONAL LOUVERS:

Use the 4-way directional louvers to direct the air flow up or down and left or right throughout the room as needed. Pivot horizontal louvers until the desired up/down direction is obtained.

Move the center handles from side to side until the desired Left/Right direction is obtained.

**Air Directional Louvers**

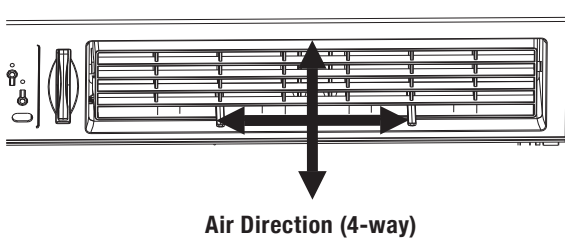

## ► ADDITIONAL THINGS YOU SHOULD KNOW:

• The Cool circuit has an automatic 3 minute time-delayed start if the unit is turned off and on quickly. After unit is turned off, leave the unit off for a minimum of 3 minutes before attempting to turn back on. This prevents overheating of the compressor and possible circuit breaker tripping. The fan will continue to run during this time.

• The control is capable of displaying temperature in degrees Fahrenheit or degrees Celsius. To convert from one to the other, press and hold the left and right TEMP/TIMER buttons (▲ and ▼) at the same time for 3 seconds.

## ► FRESH AIR VENT CONTROL

The Fresh Air Vent allows the air conditioner to:

1. Recirculate inside air (Vent Closed - Fig. A)
2. Draw fresh air into the room (Vent Open - Fig B)
3. Exchange air from the room and draw fresh air into the room (Vent and Exhaust Open - Fig C)

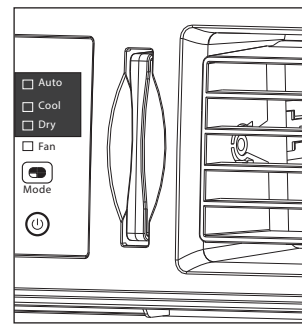

**Fig. A (VENT CLOSED)**

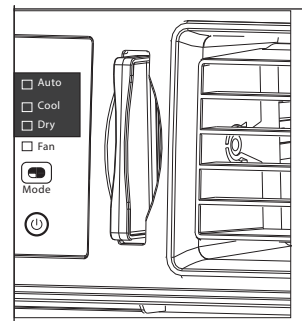

**Fig. B (VENT OPEN)**

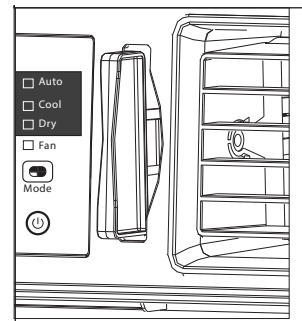

**Fig. C (VENT AND EXHAUST OPEN)**



# CARE AND CLEANING

## ⚠ CAUTION

Clean air conditioner occasionally to keep it looking and operating like new.  
**Be sure to unplug the unit before cleaning to prevent shock or fire hazards.**

### ► AIR FILTER CLEANING

The air filter should be cleaned at least every two weeks or as necessary. Trapped particles in the filter can build up, causing accumulation of frost on the cooling coils, and reducing efficiency.

- Push the vent handle to the Vent Closed position (where applicable).
- Place one hand on each side of the unit and tilt open the front panel.
- Grasp the filter by the center and pull up and out.
- Wash the filter using liquid dish-washing detergent and warm water. Rinse filter thoroughly.
- Gently shake excess water from the filter. Be sure the filter is thoroughly dry before replacing.
- As an alternative to washing the filter, vacuum the filter clean.

**NOTE:** Never use hot water over 104°F (40°C) to clean the air filter. Never attempt to operate the unit without the air filter.

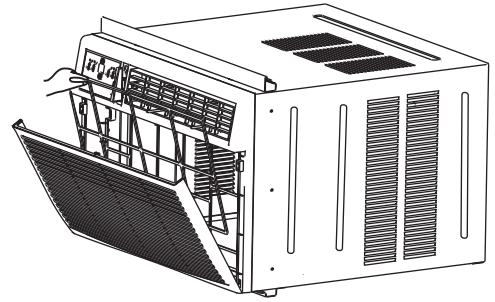

### ► CABINET CLEANING

- Be sure to unplug the air conditioner to prevent shock or fire hazard. The cabinet and front may be dusted with an oil-free cloth or with a cloth dampened in a solution of warm water and mild liquid dish-washing detergent. Rinse thoroughly and wipe dry.
- Never use harsh cleaners, wax or polish on the cabinet front.
- Be sure to wring excess water from the cloth before wiping the controls. Excess water in or around the controls may cause damage to the air conditioner.
- Plug in air conditioner after unit has dried completely.

### ► WINTER STORAGE

If air conditioner will be stored during the winter, remove it carefully from the window according to the installation instructions. Cover it with plastic or return it to the original carton.

**ALWAYS STORE UNIT IN AN UPRIGHT POSITION AND IN A COOL, DRY LOCATION.**

The design and specifications are subject to change without prior notice for product improvement. Consult with the sales agency or manufacturer for details.



# TROUBLESHOOTING

**BEFORE CALLING FOR SERVICE, PLEASE REVIEW THE CHART BELOW**

ISSUE	POSSIBLE CAUSES
<p><b>AIR CONDITIONER NOT COOLING ROOM, OR NOT BLOWING COLD AIR</b></p>	<ul style="list-style-type: none"> <li>• Be sure unit is not too large or too small for the area of the room.</li> <li>• Verify that all doors, windows, curtains and any other openings are closed. Verify nothing is obstructing the front grille of unit, such as curtains, etc.</li> <li>• Allow enough time for room to cool, especially if outside temp is very high.</li> <li>• Check that the filter is not dirty and louvers are open all the way and blowing in the desired direction.</li> <li>• Check that unit is set to COOL mode and that temperature is down enough (but not too low).</li> <li>• If unit is near a heat source, such as a stove, etc., relocate unit.</li> <li>• If air coming from unit is cool to the touch, then unit is working properly; please double check the first three bullet points above.</li> <li>• If using Follow Me remote feature, move remote away from unit.</li> <li>• Temperature sensor behind air filter touching cold coil. These two elements should not be touching. Carefully straighten tube away from coil.</li> <li>• Unplug unit for at least 5 minutes. Follow Reset instructions on plug.</li> </ul>
<p><b>AIR CONDITIONER COOLING BUT ROOM IS TOO WARM - ICE FORMING ON COOLING COIL BEHIND DECORATIVE FRONT</b></p>	<ul style="list-style-type: none"> <li>• Outdoor temperature is below 64°F (18°C). To defrost the coil, set to FAN only mode.</li> <li>• Air filter may be dirty. Clean filter. Refer to Care and Cleaning section. To defrost, set to FAN only mode.</li> <li>• Thermostat is set too cold for night-time cooling. To defrost the coil, set to FAN only mode. Then, set temperature to a higher setting.</li> </ul>
<p><b>AIR CONDITIONER CYCLING ON AND OFF TOO FREQUENTLY OR NOT ENOUGH</b></p>	<ul style="list-style-type: none"> <li>• Be sure unit is not too large or too small for the area of the room.</li> <li>• Remove grille and make sure the temperature sensor is not too close to the coils. These two elements should not be touching. Carefully straighten tube away from coil.</li> <li>• Make sure nothing is blocking the grille or side vents.</li> <li>• Make sure there is no dirt or debris inside the unit or on the filter.</li> </ul>
<p><b>UNIT WILL NOT TURN ON</b></p>	<ul style="list-style-type: none"> <li>• Reset circuit breaker. Make sure there are not too many items (i.e. lamps, TV's, etc.) working off the same breaker.</li> <li>• Check plug connection.</li> <li>• If plug is operating on an on/off switch, be sure that the switch is 'on'.</li> <li>• Try plugging unit into another outlet.</li> <li>• Unplug unit for at least 5 minutes. Follow Reset instructions on plug.</li> </ul>
<p><b>UNIT BLOWS FUSES OR POPS CIRCUIT BREAKER</b></p>	<ul style="list-style-type: none"> <li>• Make sure there are enough available amps on the circuit for the air conditioner.</li> <li>• Large units which run on a 230v will require a dedicated 20 or 30 amp circuit.</li> </ul>
<p><b>AIR CONDITIONER IS MAKING NOISES</b></p>	<ul style="list-style-type: none"> <li>• Check to be sure the unit is free from debris such as leaves, sticks, etc. Verify nothing is obstructing the unit.</li> <li>• Check the fan blade for cracks or chips.</li> <li>• Make sure the unit is properly and securely mounted inside the window or wall.</li> <li>• Clean the air filter.</li> </ul>
<p><b>WATER PUDDLES INSIDE UNIT OR IS COMING INTO ROOM</b></p>	<ul style="list-style-type: none"> <li>• Adjust the slope of the unit so that it drains downward toward the exterior of the home. (See Installation Instructions.)</li> <li>• Make sure that there is no debris blocking the drainage area of the unit.</li> </ul>
<p><b>WATER DRIPPING OUTSIDE</b></p>	<ul style="list-style-type: none"> <li>• Unit is removing a large quantity of moisture from a humid room. This is normal during excessively humid days.</li> </ul>
<p><b>REMOTE SENSING / FOLLOW ME DEACTIVATING PREMATURELY</b></p>	<ul style="list-style-type: none"> <li>• Remote control not located within range. Place remote control within 20 ft and 180° radius of the front of the unit.</li> <li>• Remote control signal obstructed. Remove obstruction.</li> </ul>

## NOTE

A highly recommended troubleshoot for any issue in general consists of turning off unit and unplugging for 5 minutes. It is also recommended to try another wall outlet. For further assistance, contact Consumer Services at 844-472-2473.



**Distributed by:**

Perfect Aire, LLC  
5401 Dansher Rd.  
Countryside, IL 60525

**844-4PA-AIRE | 844-472-2473**  
**[www.perfectaire.us](http://www.perfectaire.us)**

PA/User\_3PACH8000\_3PACH12000/03072019

Specification and performance data is subject to change without notice.

Printed in China