

I870101133A1/A2

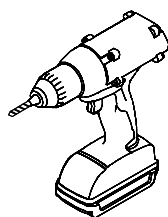

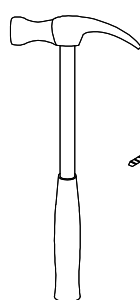

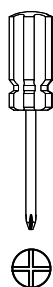
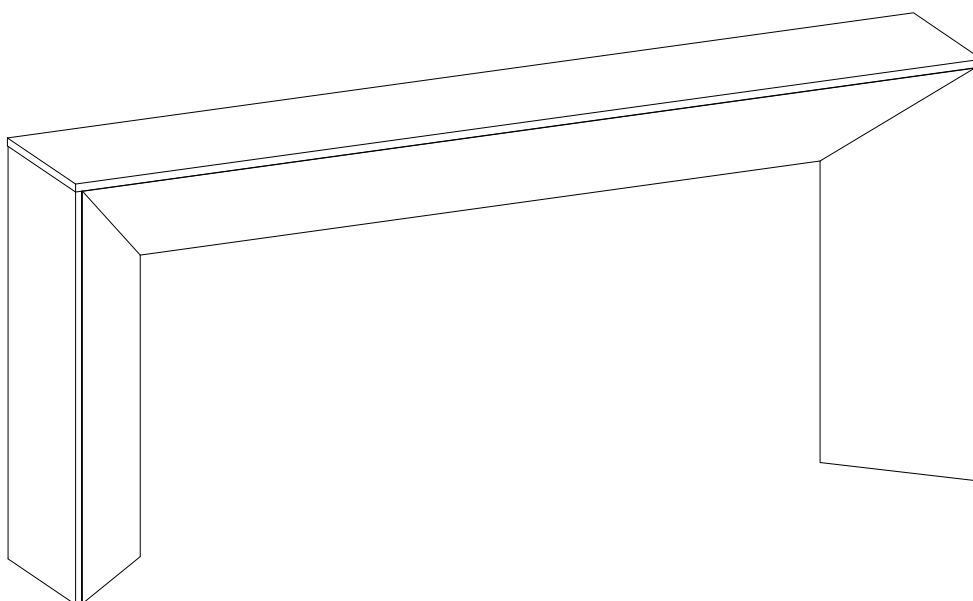

**Tools required
(not included)**

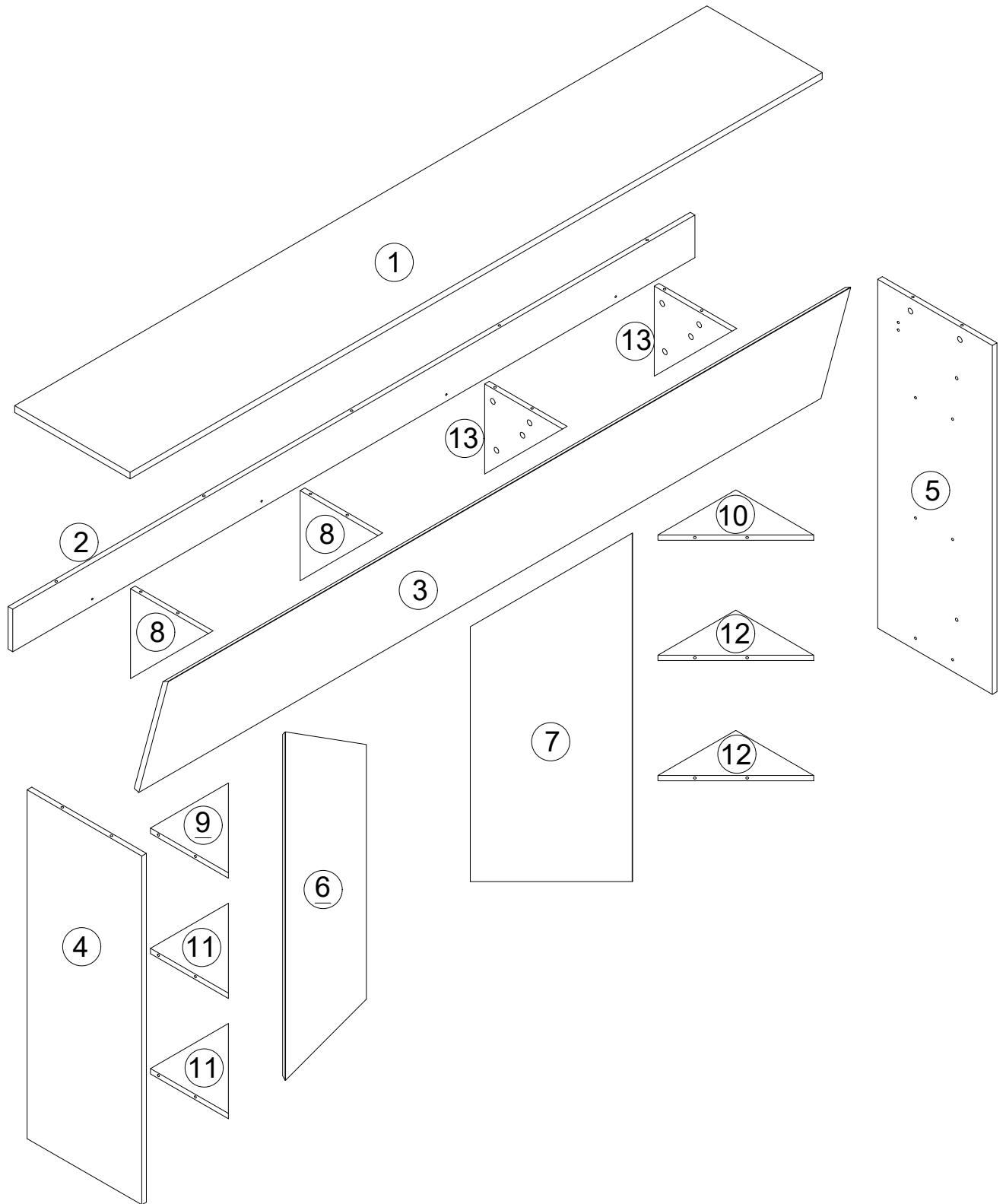
2 people for assembly

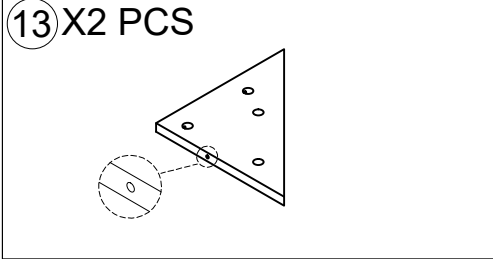
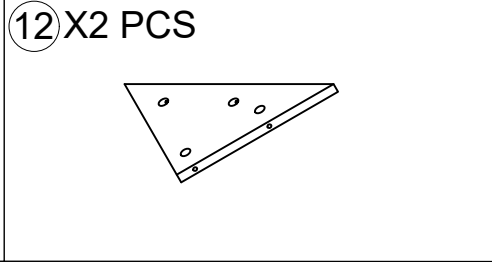
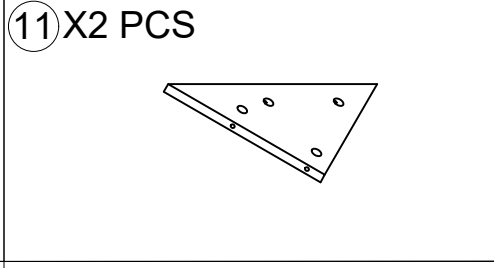
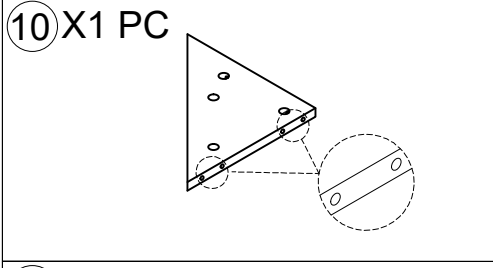
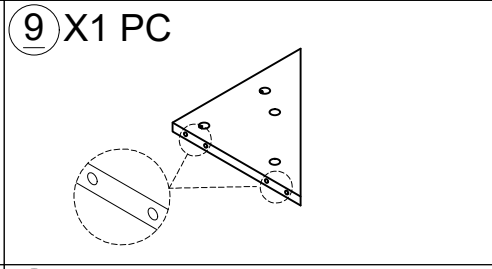
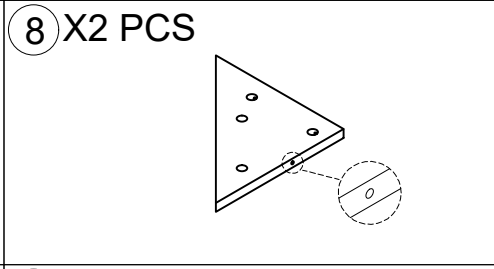
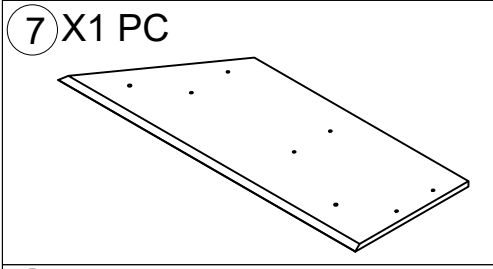
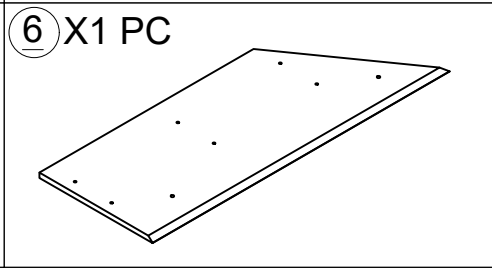
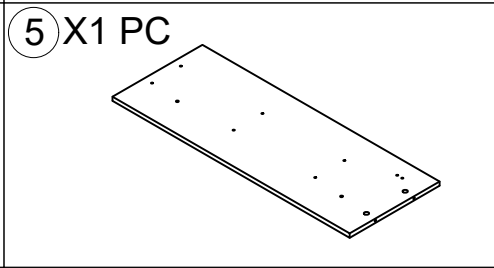
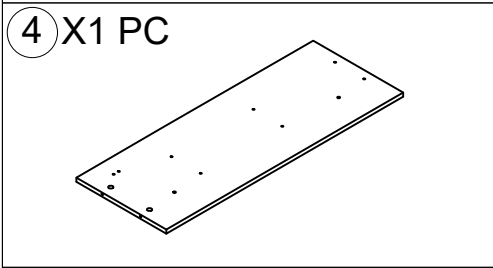
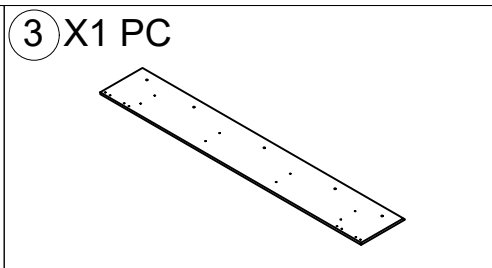
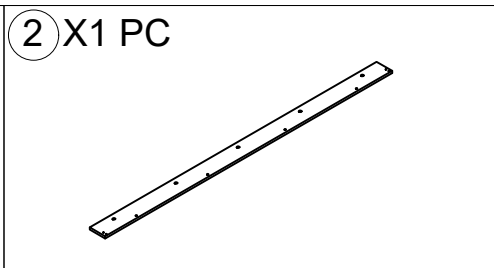
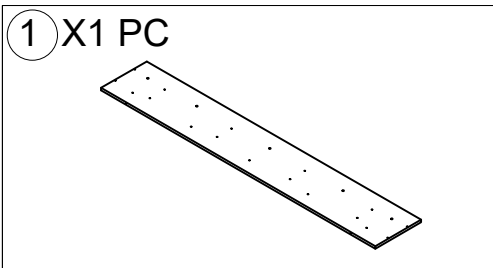
ASSEMBLY OVERVIEW

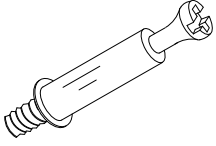

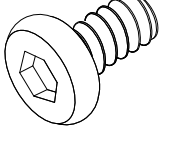
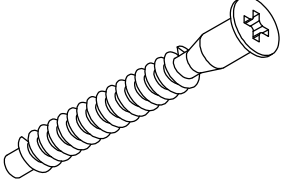
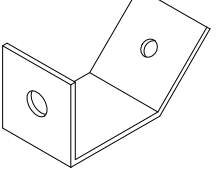
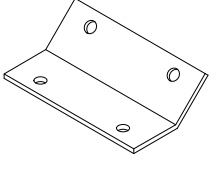

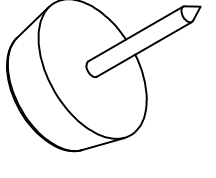
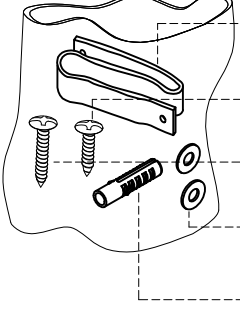
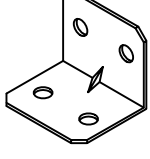
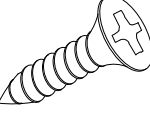
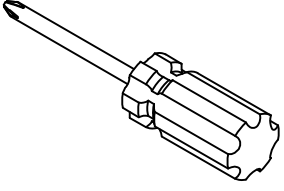
<p>A</p>  <p>Ø6*35mm 49+5 PCS</p>	<p>B</p>  <p>Ø15*9mm 49+5 PCS</p>	<p>C</p>  <p>Ø3.5*12mm 16+2 PCS</p>	<p>D</p>  <p>M6*10mm 18+2 PCS</p>
<p>E</p>  <p>Ø5*40mm 4+1PC</p>	<p>F</p>  <p>62.5*32*25mm 9 PCS</p>	<p>G</p>  <p>52*36.5*16.5mm 4 PCS</p>	<p>H</p>  <p>4mm 1 PC</p>
<p>I</p>  <p>Ø12*5mm 6+1 PC</p>	<p>J</p>  <p>2 SET</p> <ul style="list-style-type: none"> J-1 200mm J-2 Ø3.5*12mm J-3 Ø4*40mm J-4 Ø12*1mm J-5 Ø8*35mm 		<p>K</p>  <p>K-1 2 PCS 30*20*20mm</p>  <p>K-2 8+1 PC Ø3.5*12mm</p>
 <p>1 PC</p>			

Instructions For Fastening CAM-BOLT and CAM-LOCK

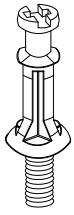

CAM-BOLT

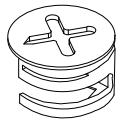

CAM-LOCK

Tools Required

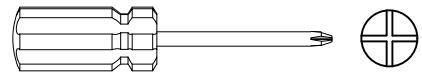

INSERTING AND TIGHTENING CAM-BOLT

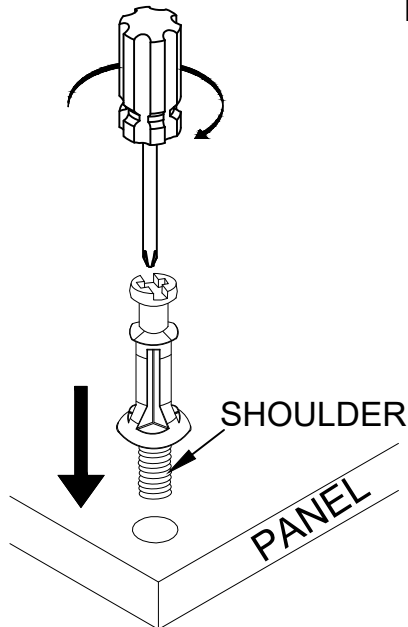

Place Cam-bolt on pre-drilled hole and screw in vertically

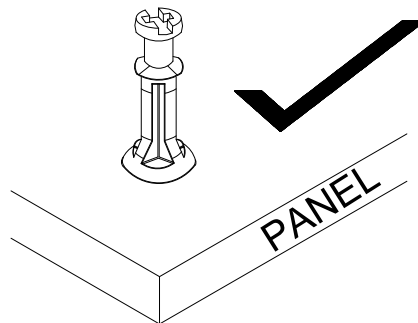

Shoulder is flushed (on the same level) with the panel.

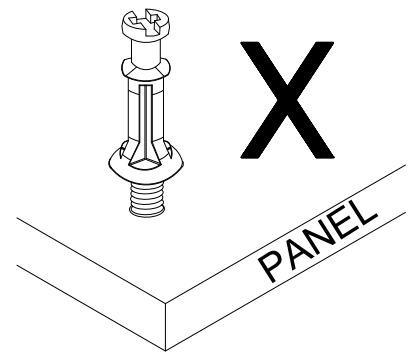

Shoulder is above the panel.

Place Cam-bolt on the designated pre-drilled holes on the panel. Use a Phillips Screwdriver to screw-in Cam-bolt vertically until shoulder is flushed (on the same level) with panel.

INSERTING CAM-LOCK

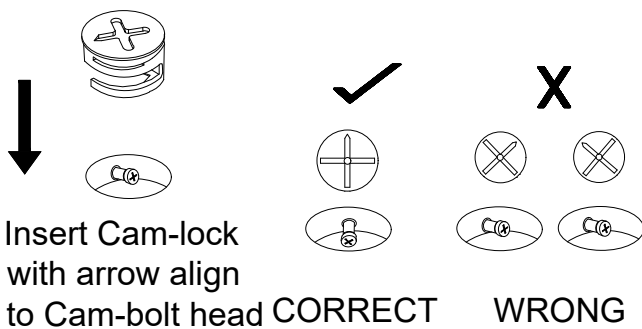

Insert Cam-lock with arrow align to Cam-bolt head **CORRECT**

WRONG

TIGHTENING CAM-LOCK

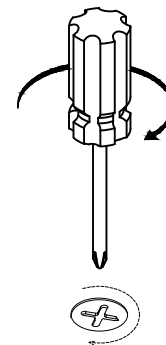

Use a Flat-head Screwdriver to turn Camlock clockwise so it locks onto the head of the Cam-bolt. Turn until it is snug (about 3/4ths of a turn) -- over-tightening could damage Cam-lock or/and Cam-bolt.

Align the arrow on the Cam-lock to the Cam-bolt head and insert the Cam-lock. Ensure Cam-lock is fully inserted.

1

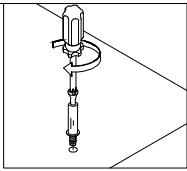

A x12

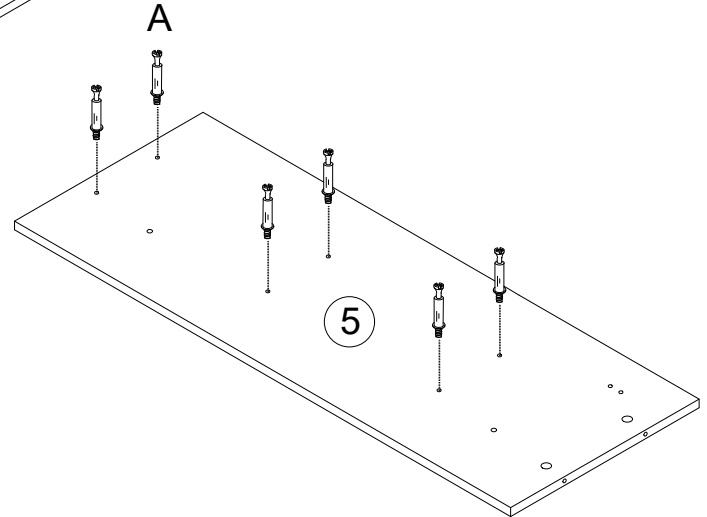
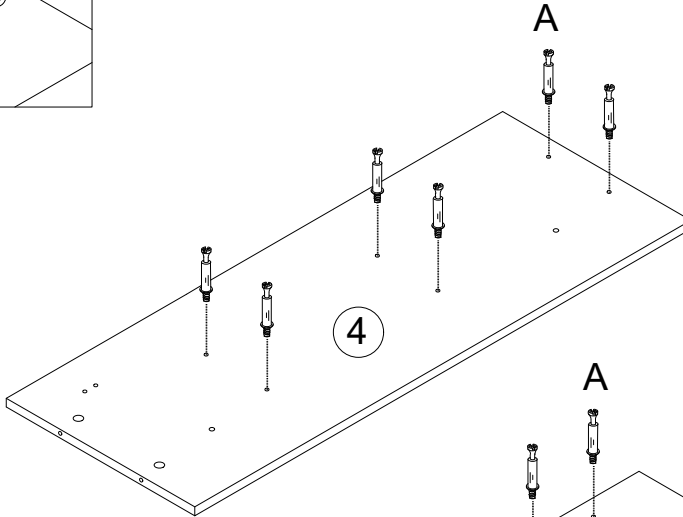
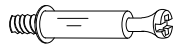

2

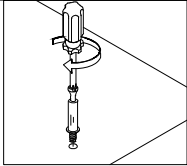

A x12

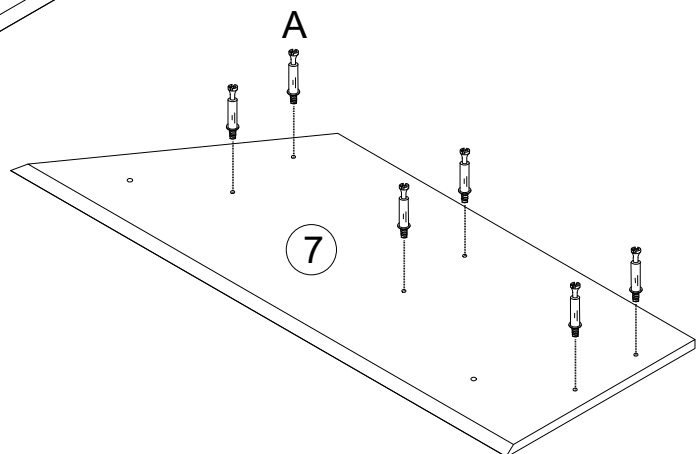
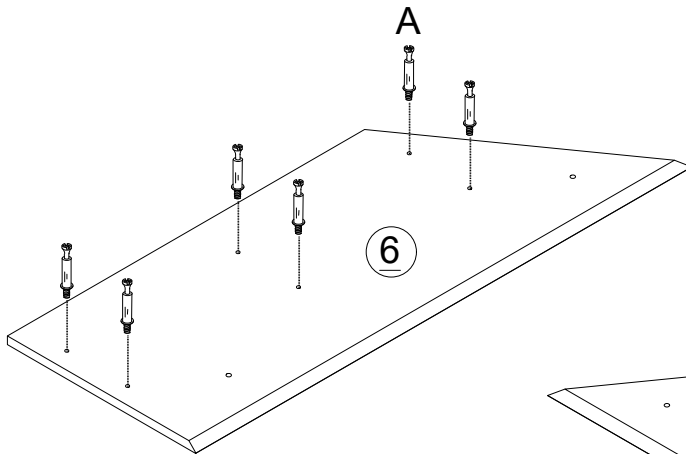
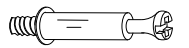

3

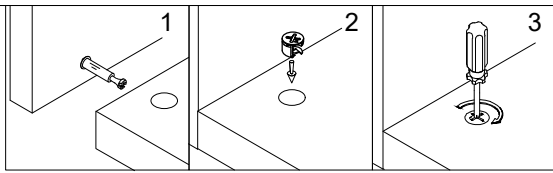

B x6

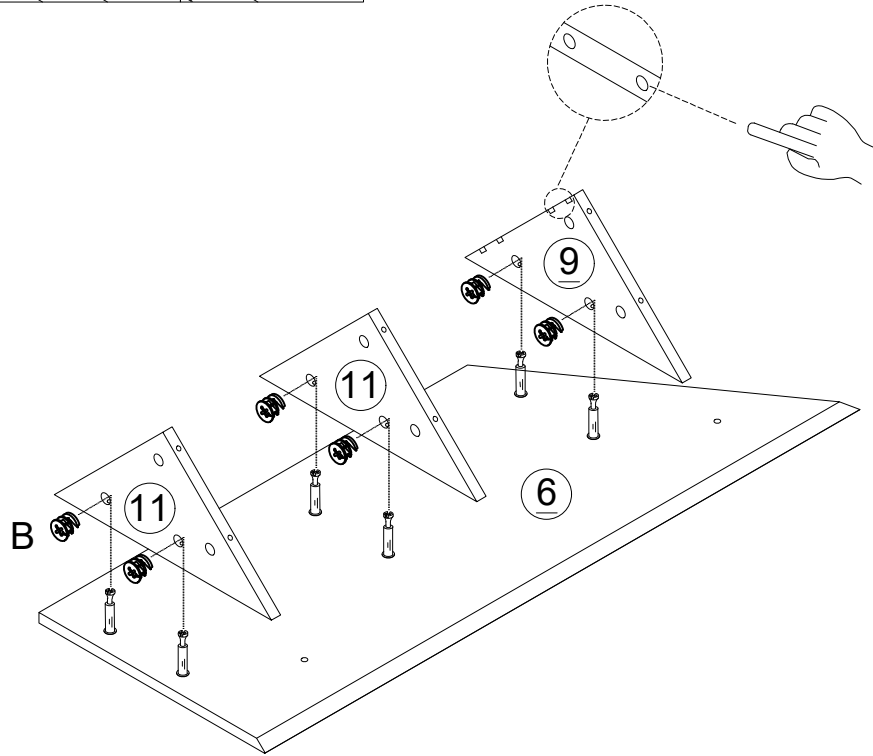

4

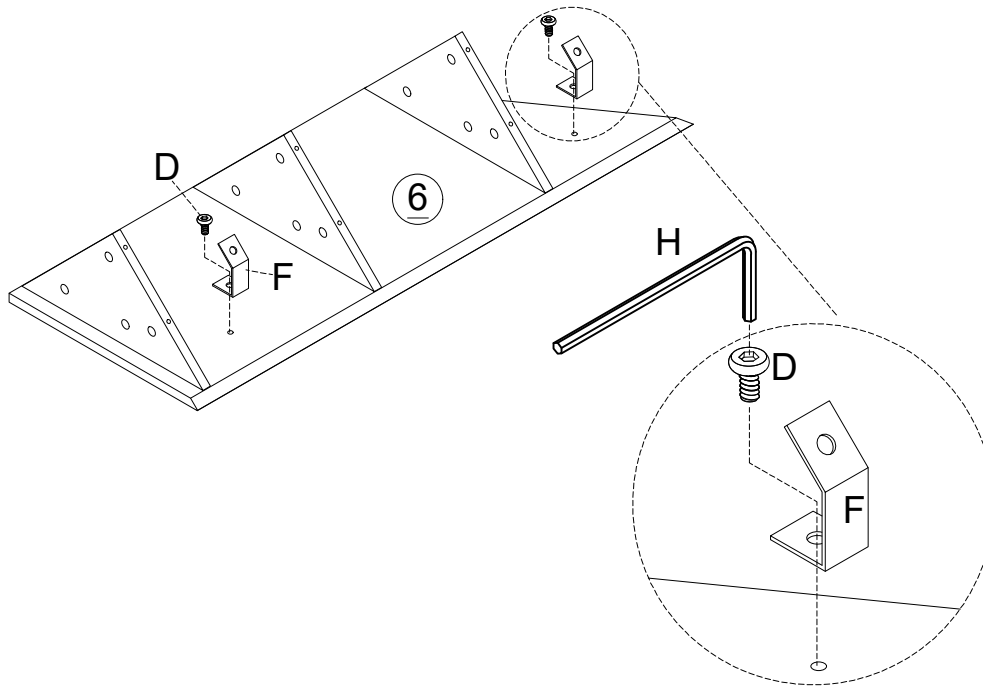

D x2



F x2

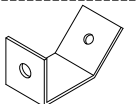

H x1



5

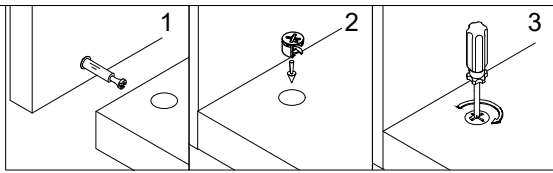

B x6

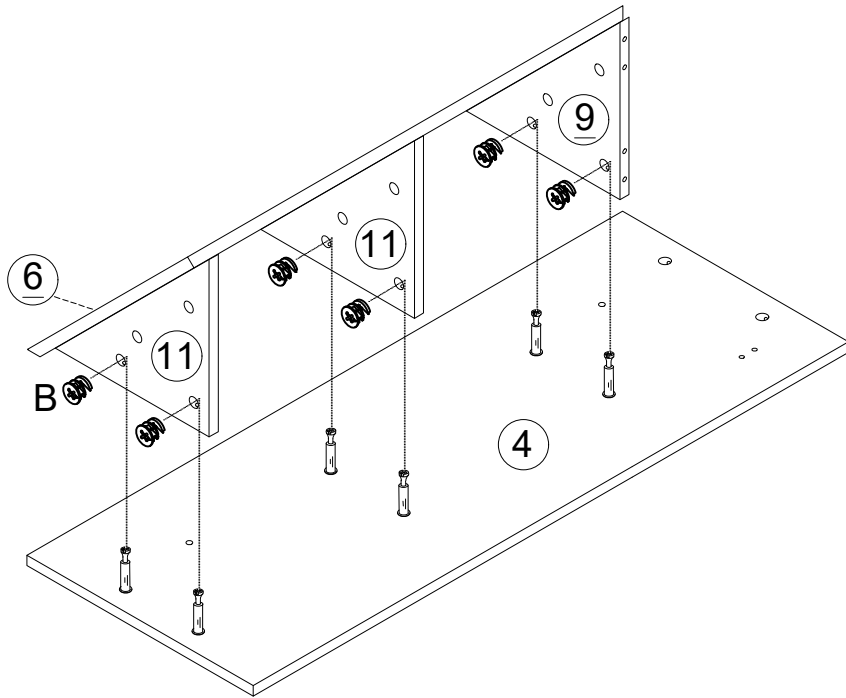

6

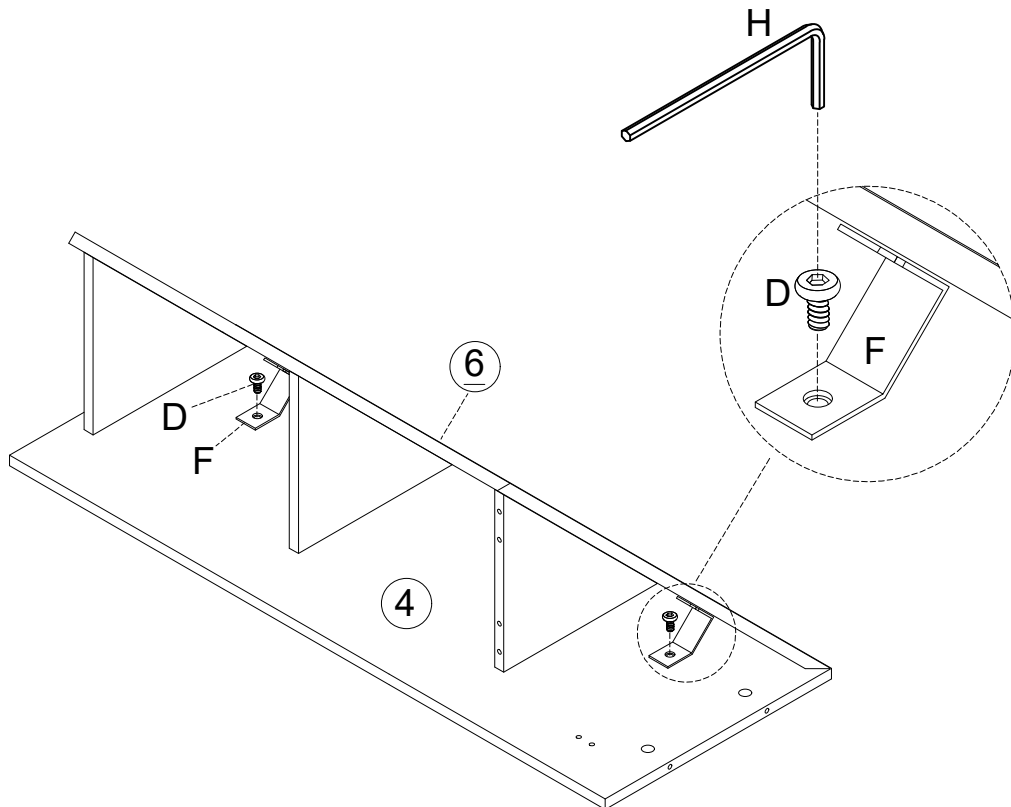

D x2



H x1



7

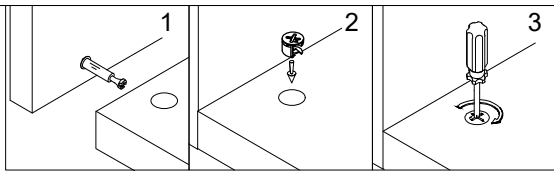

B x6

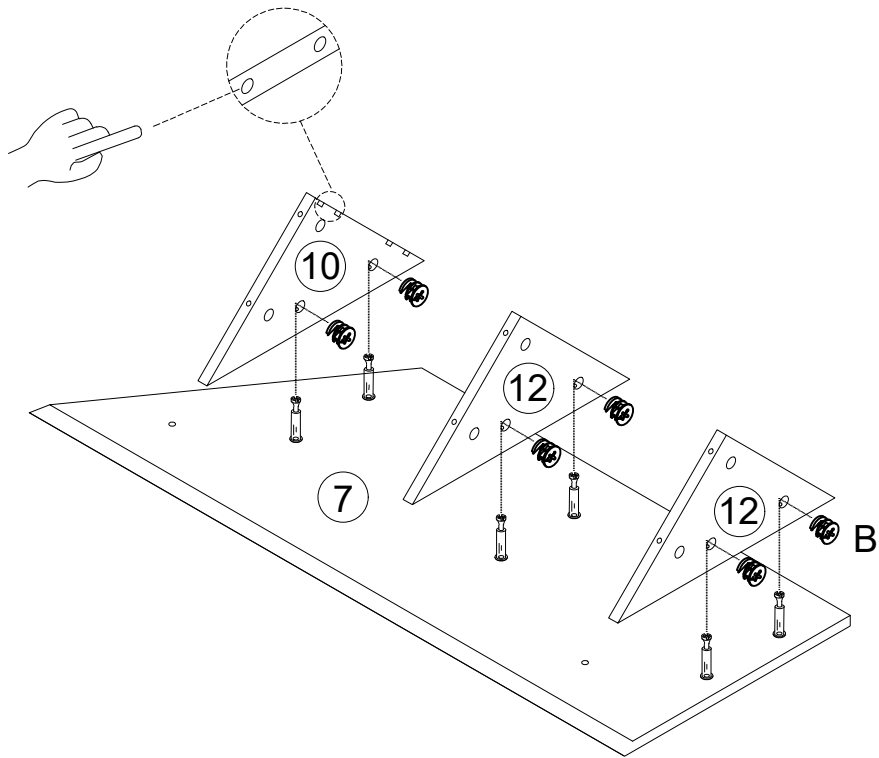

8

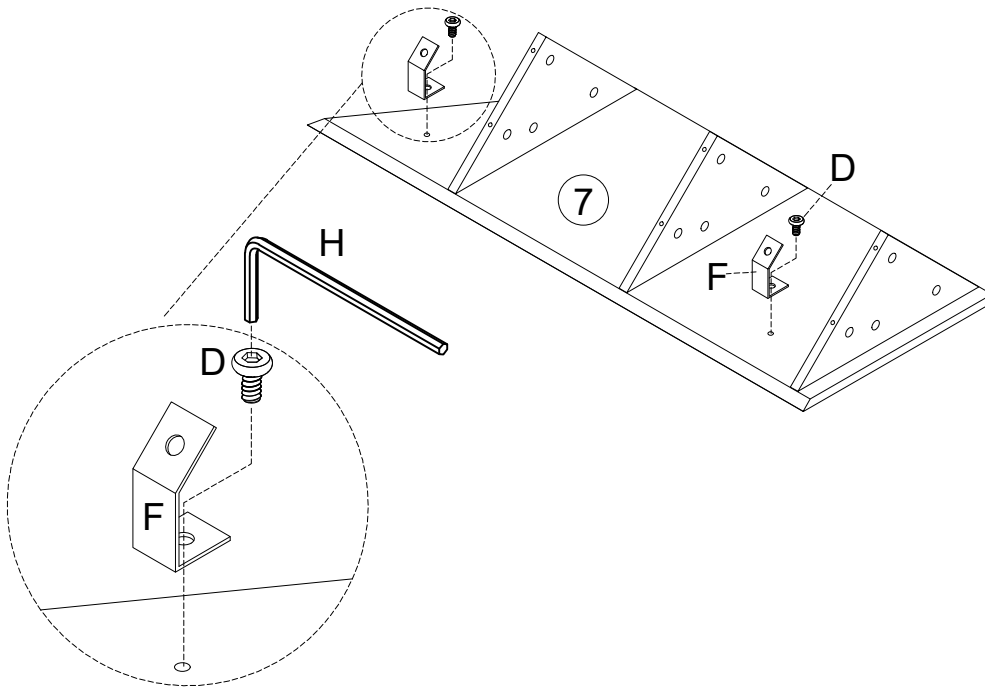

D x2



F x2

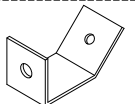

H x1



9

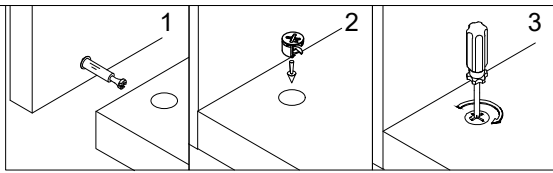

B x6

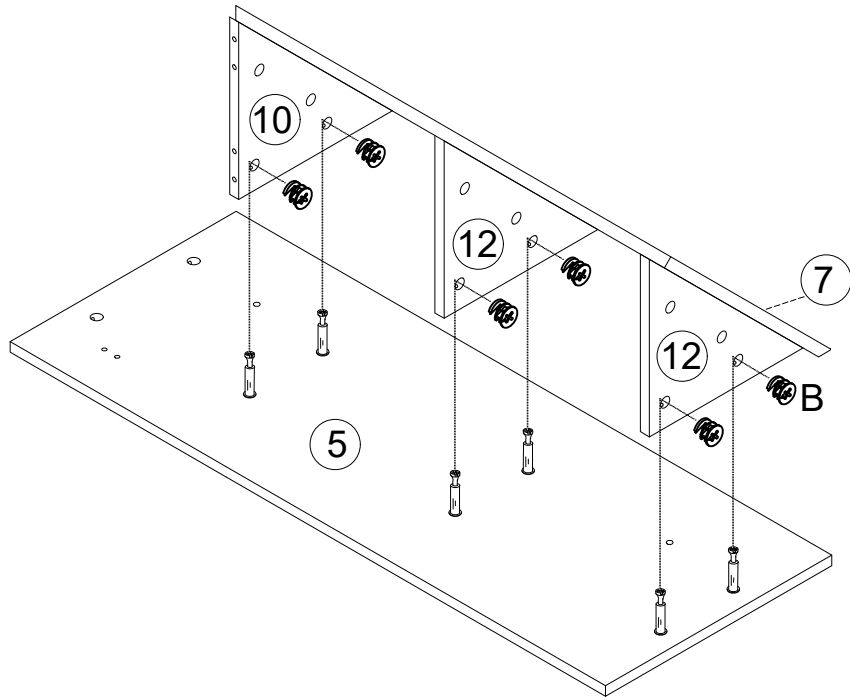

10

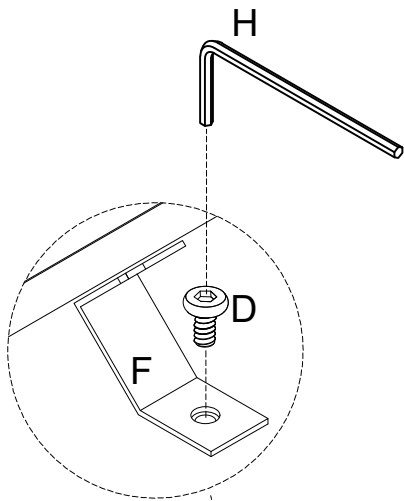

D x2

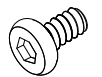

H x1

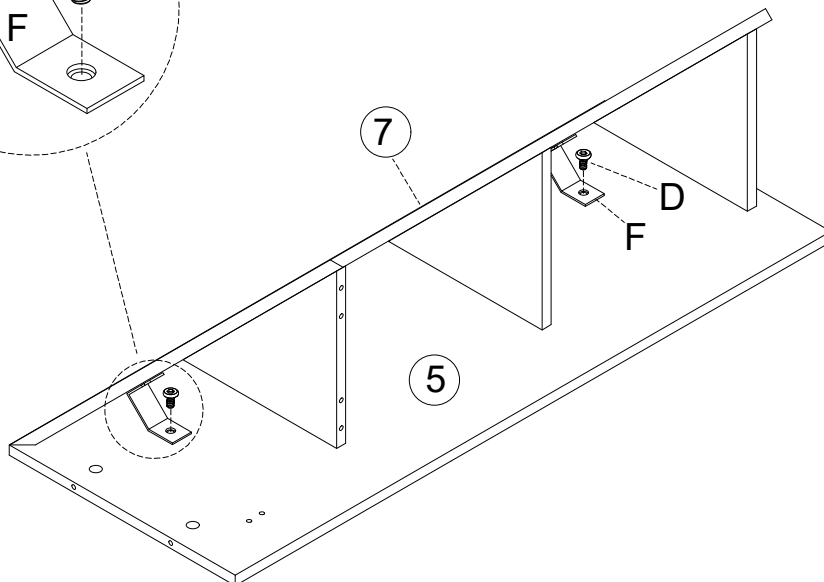

11

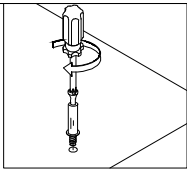

A x25

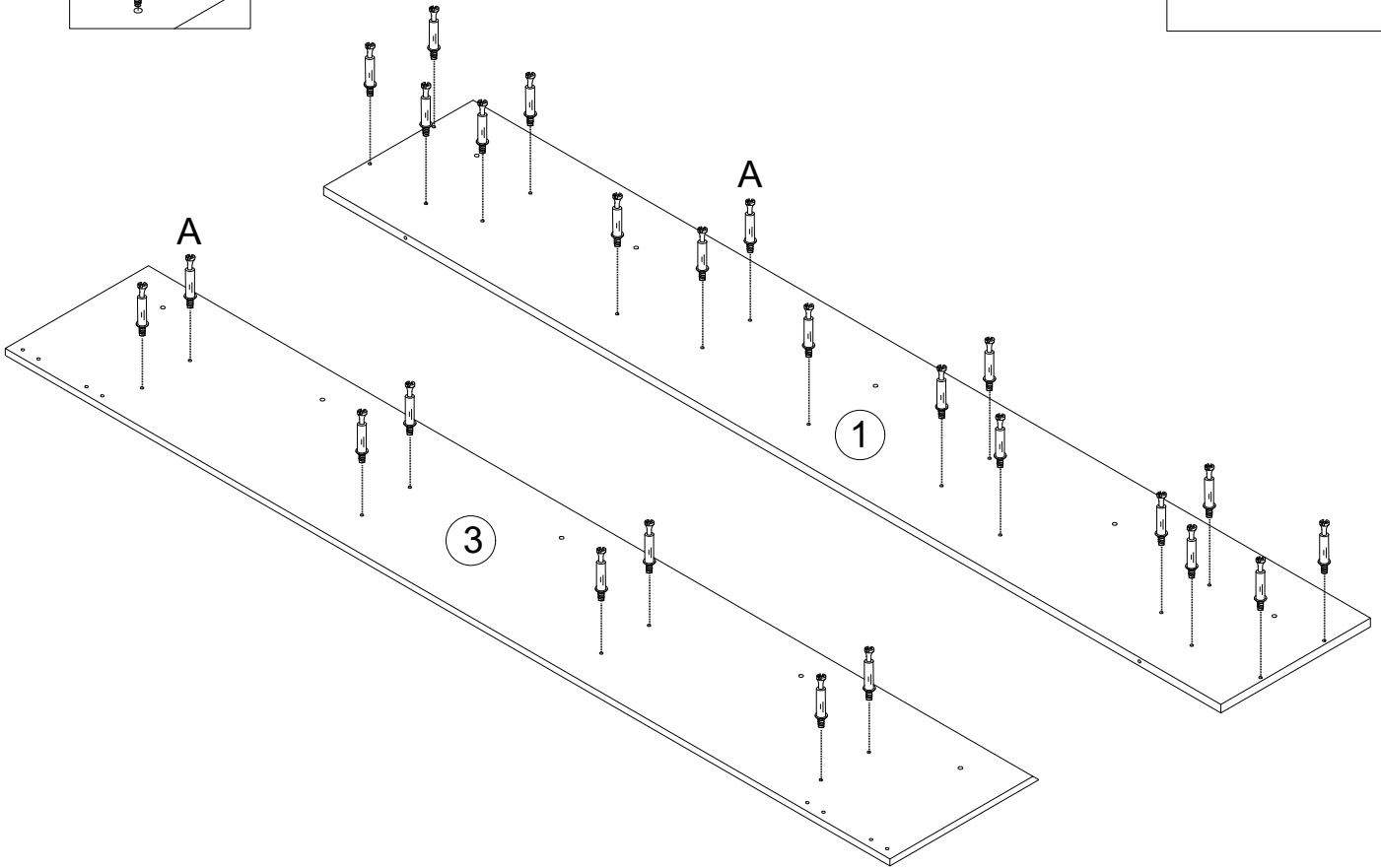
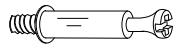

12

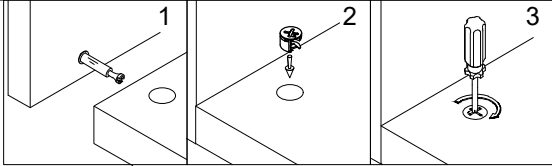

B x8

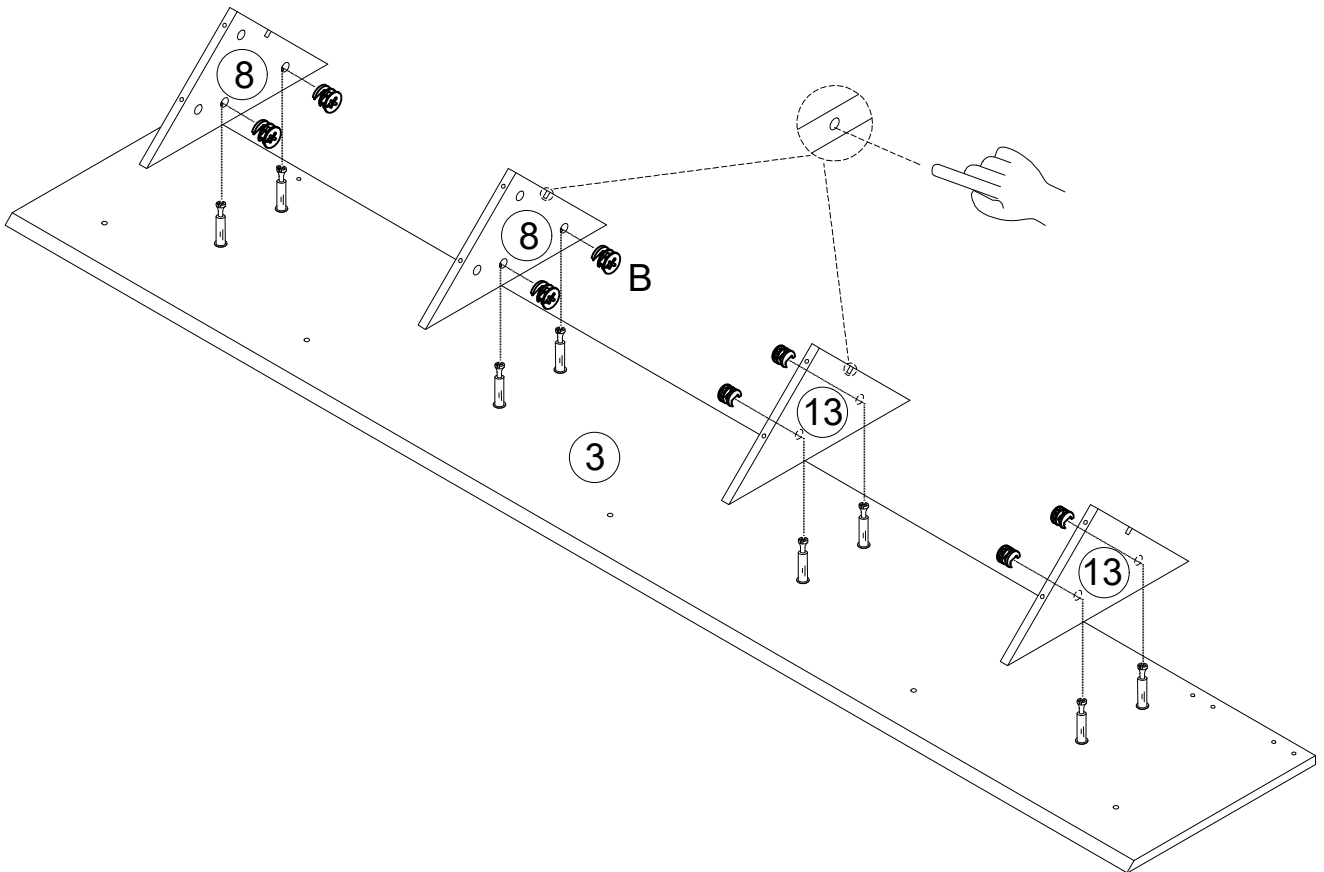

13

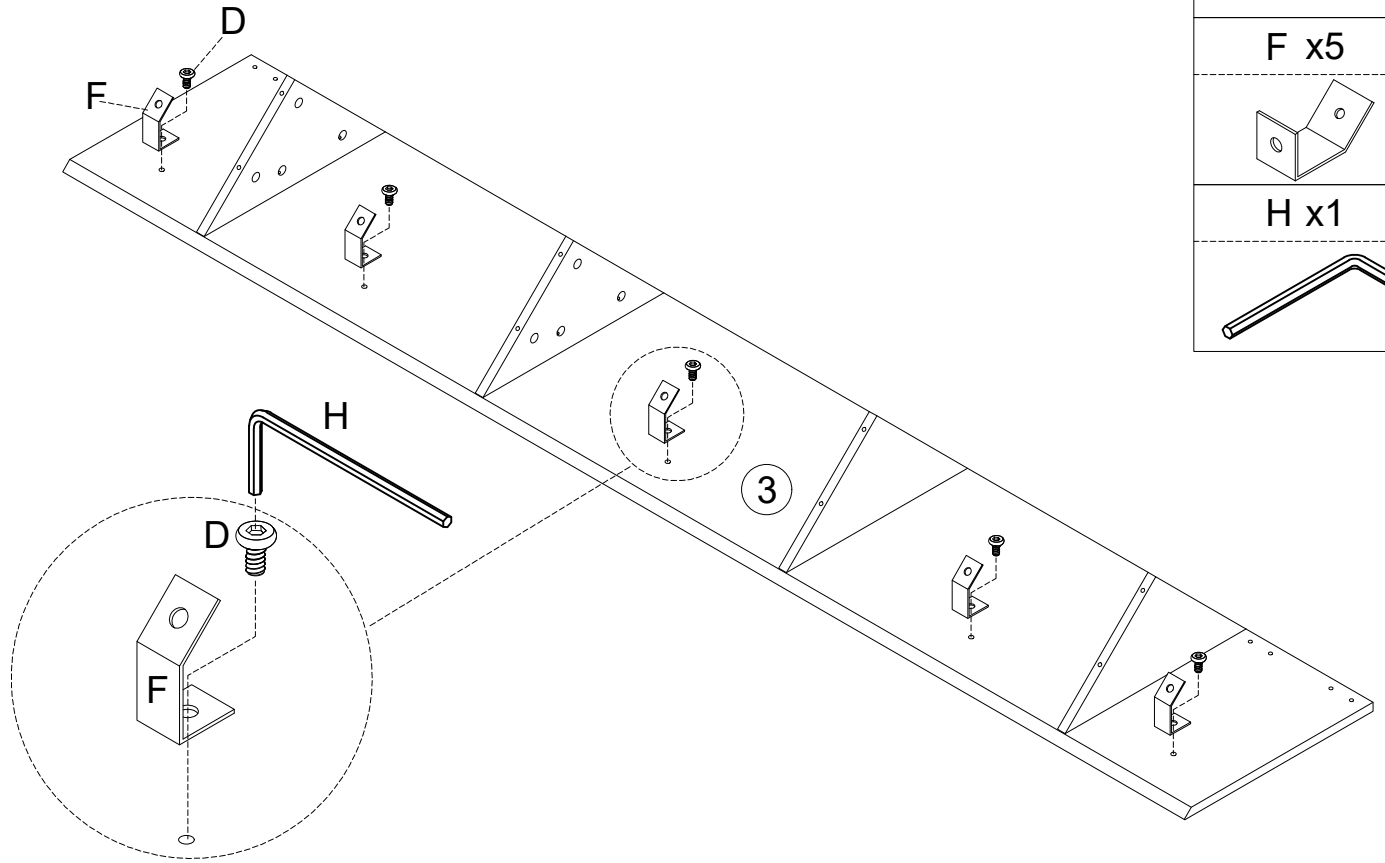

D x5



F x5

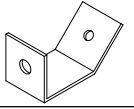

H x1



14

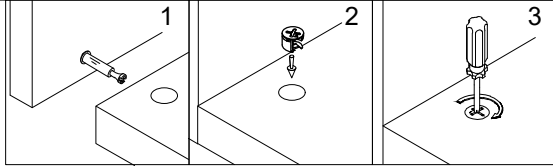

B x8

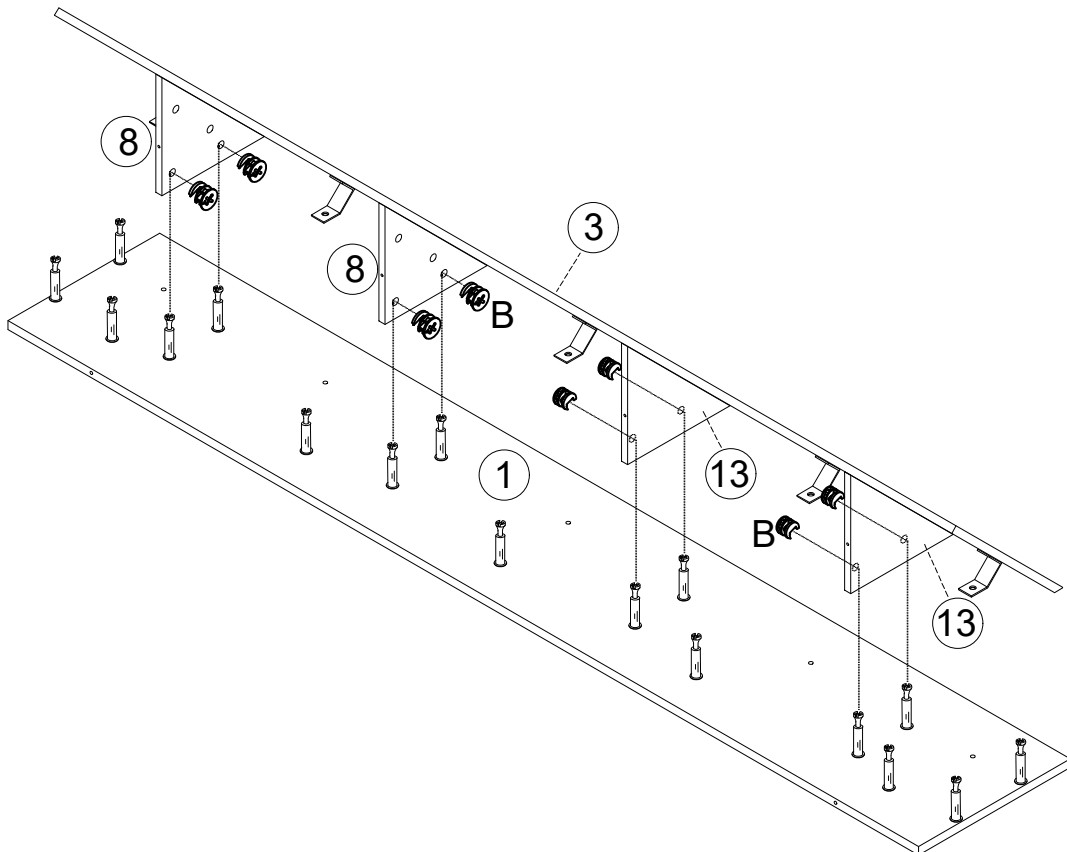

15

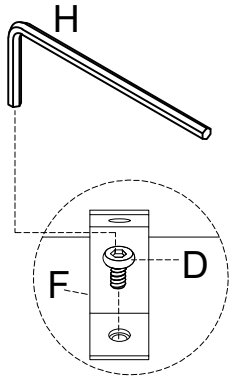

D x5



H x1

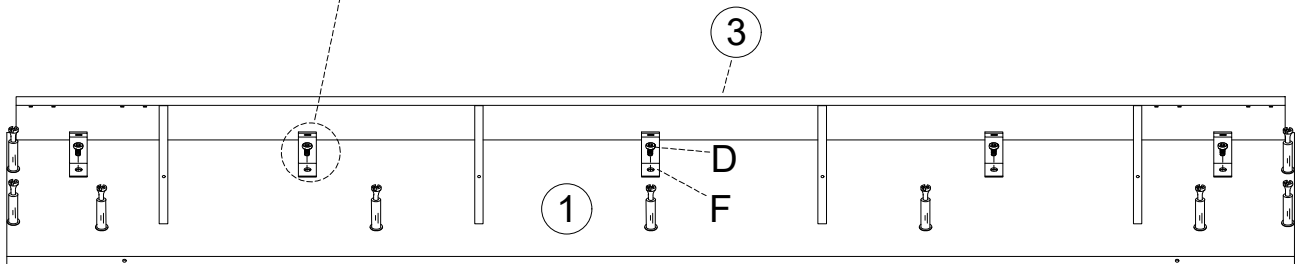

16

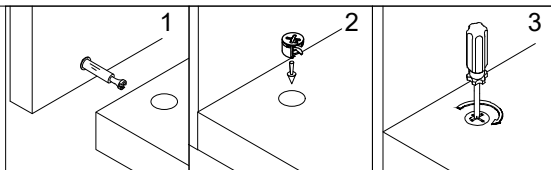

B x2

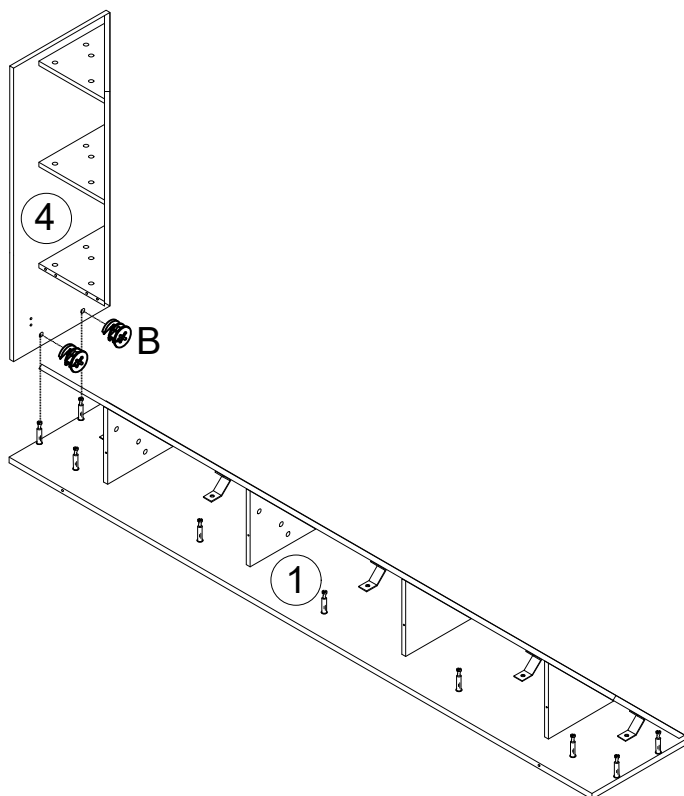

17

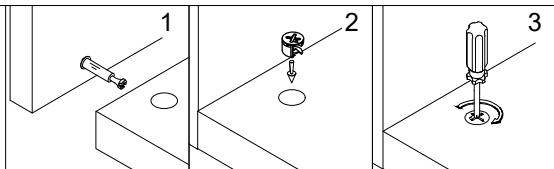

B x2

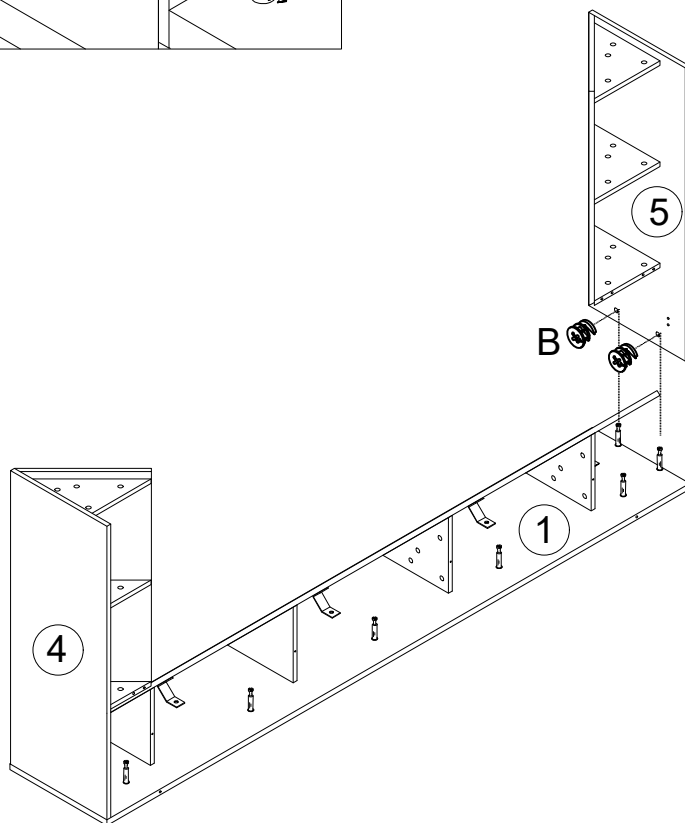

18

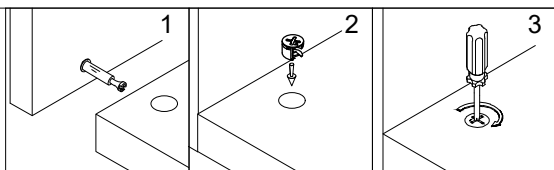

B x5

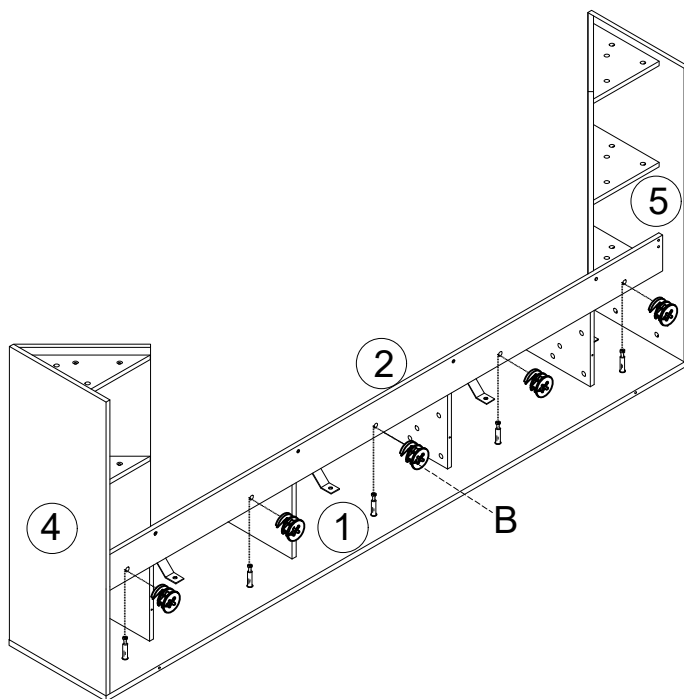

19

E x4

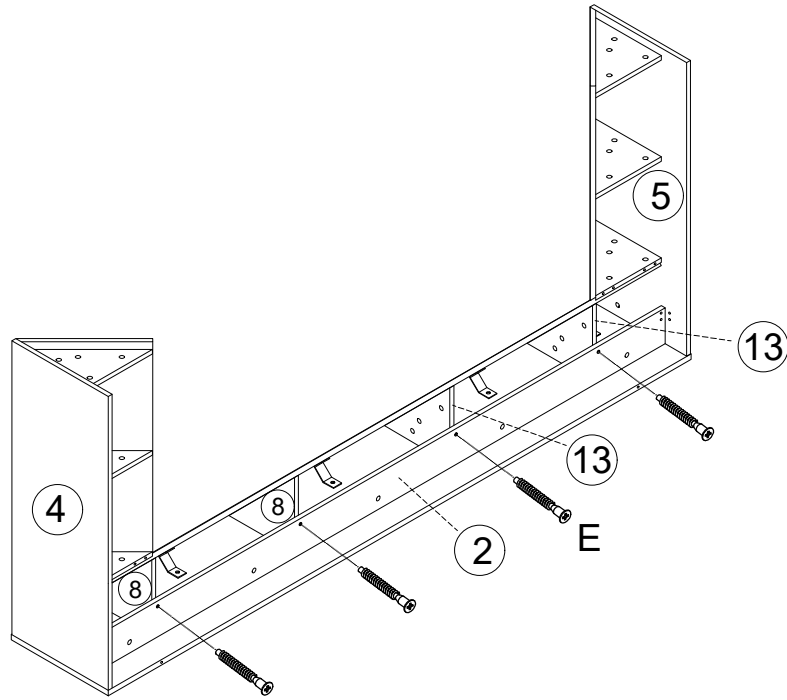
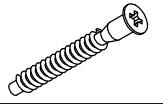

20

I x6

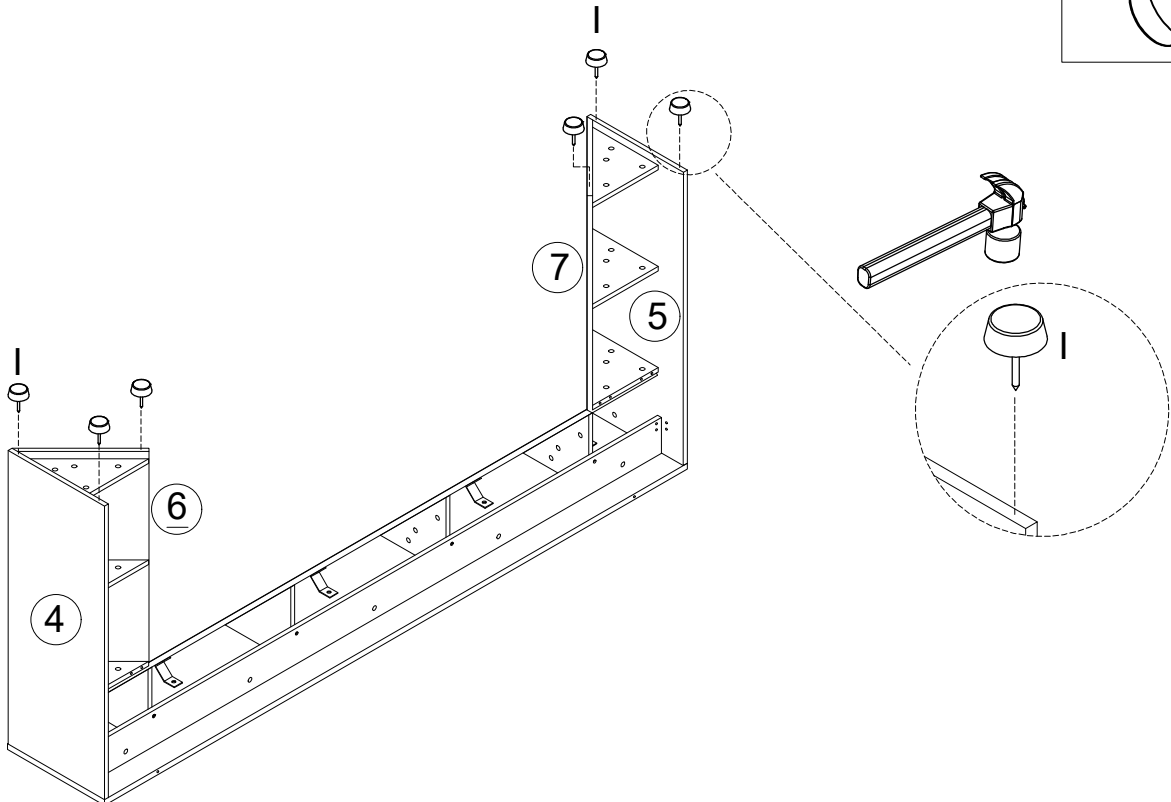

21

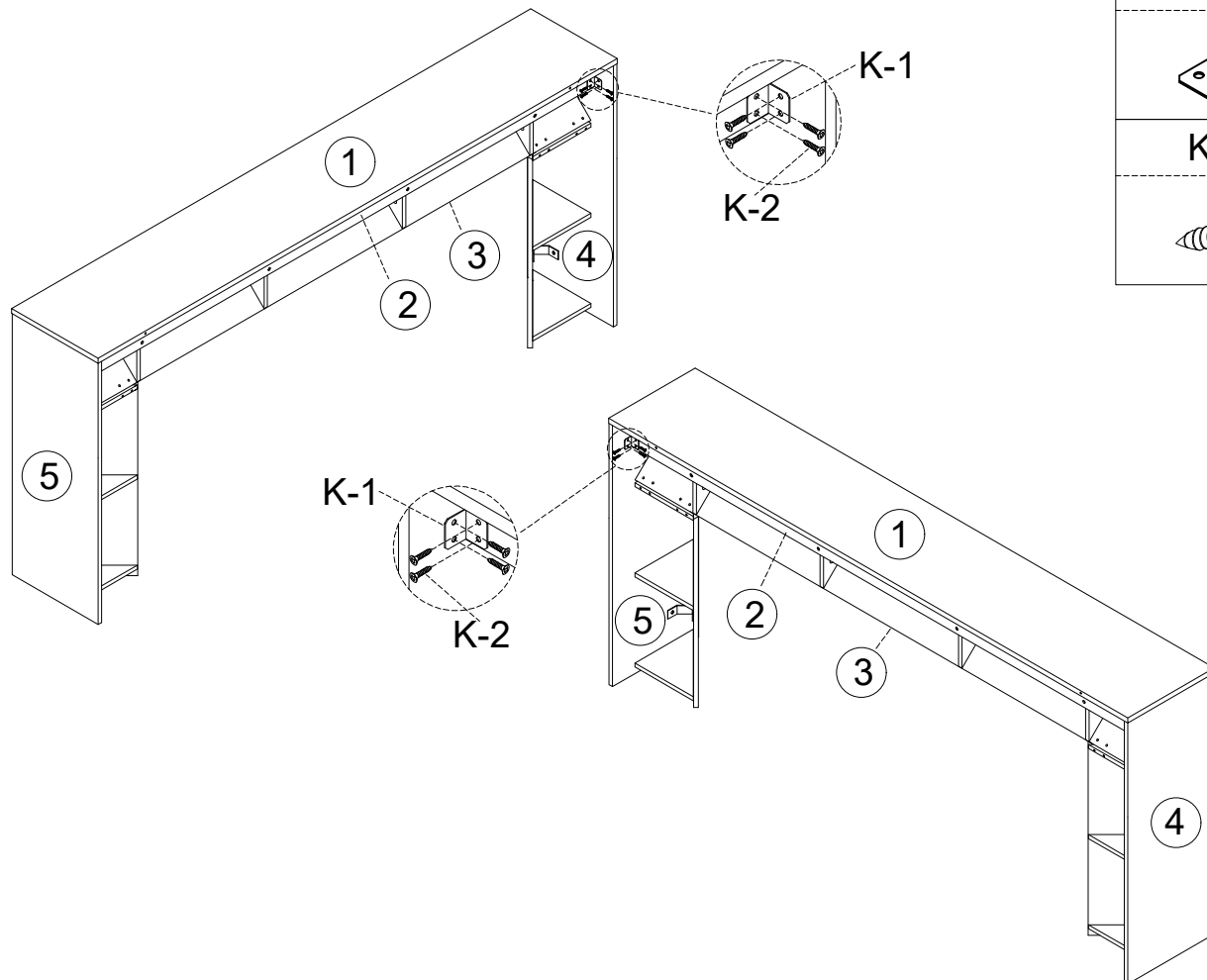

K-1 x2



K-2 x8



22

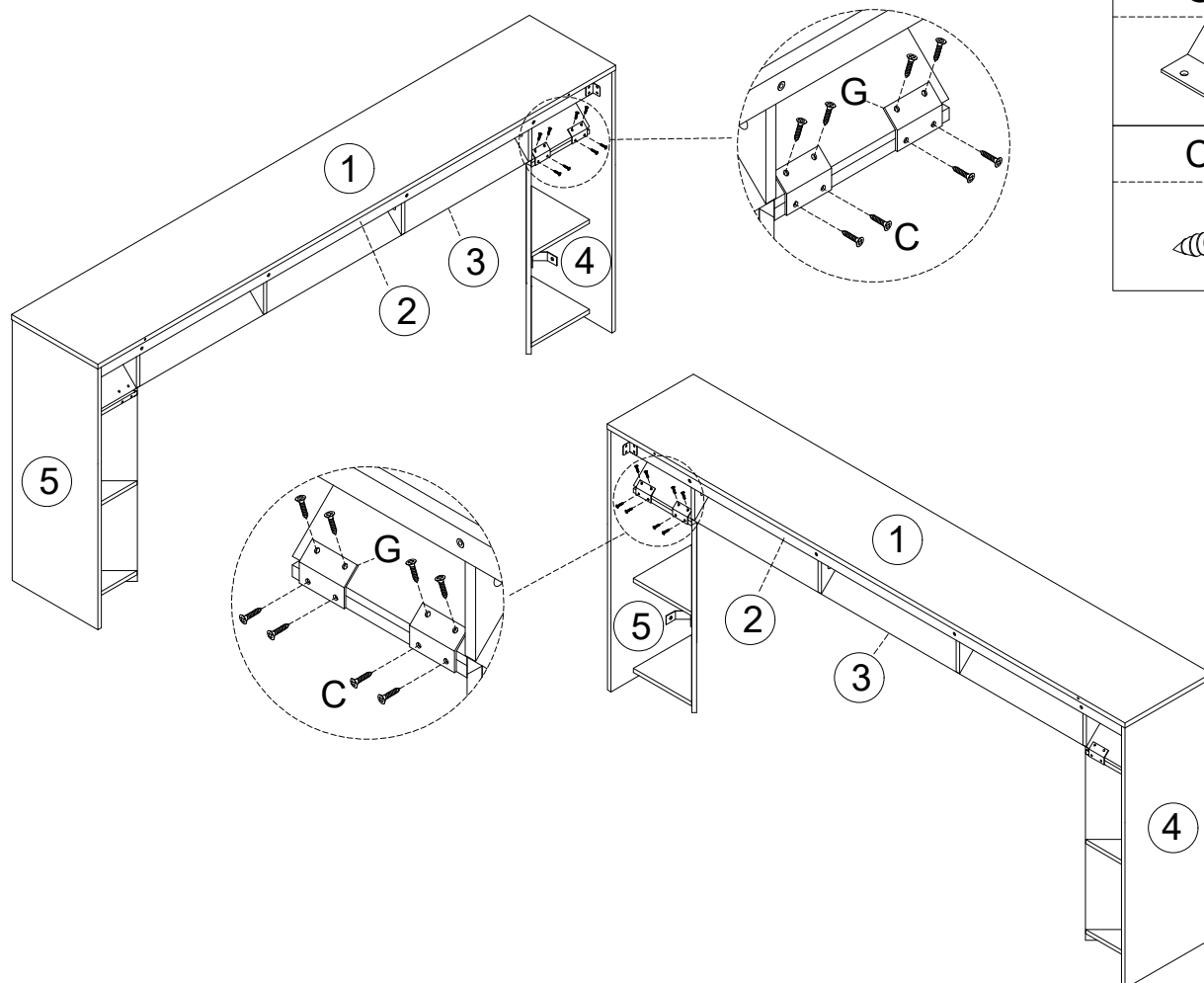

G x4

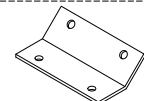

C x16



J x2

J-1

J-3

J-2

J-5

J-4

(2)

Wall

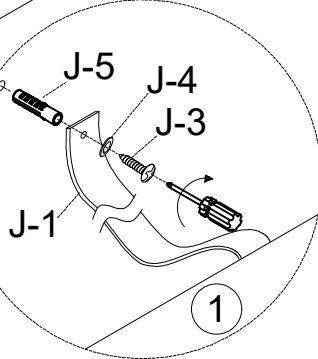

(1)

(1)

J-4

J-2

J-1

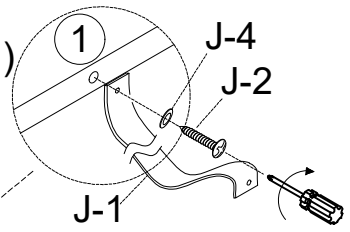

Wall

