



XOOTR24BS
 SPACE SAVING OVER-THE-RANGE
 MICROWAVE OVEN + VENTILATION

HOW BEAUTIFUL KITCHENS BREATHE



XOOTR24BS

- 1000W | 1.34 cu ft Microwave
- Touch Controls w 10 Power Levels
- Sensor Cooking and Auto-Defrost
- 2 Speed Blower 105 / 300 CFM

24" OVER-THE-RANGE MICROWAVE OVEN
 Perfect for smaller kitchens

This elegant space saving appliance is both an efficient, fully featured microwave oven and kitchen ventilation system capable of either recirculation for installations where venting outside is not possible, or ducted operating from either the top or rear of the unit.

Small in size - big on functionality. just what you would expect from XO.

WORLD CLASS SERVICE | COMPREHENSIVE WARRANTIES
 OUR LASTING COMMITMENT TO YOU



XOOTER24BS

OVER-THE-RANGE MICROWAVE OVEN

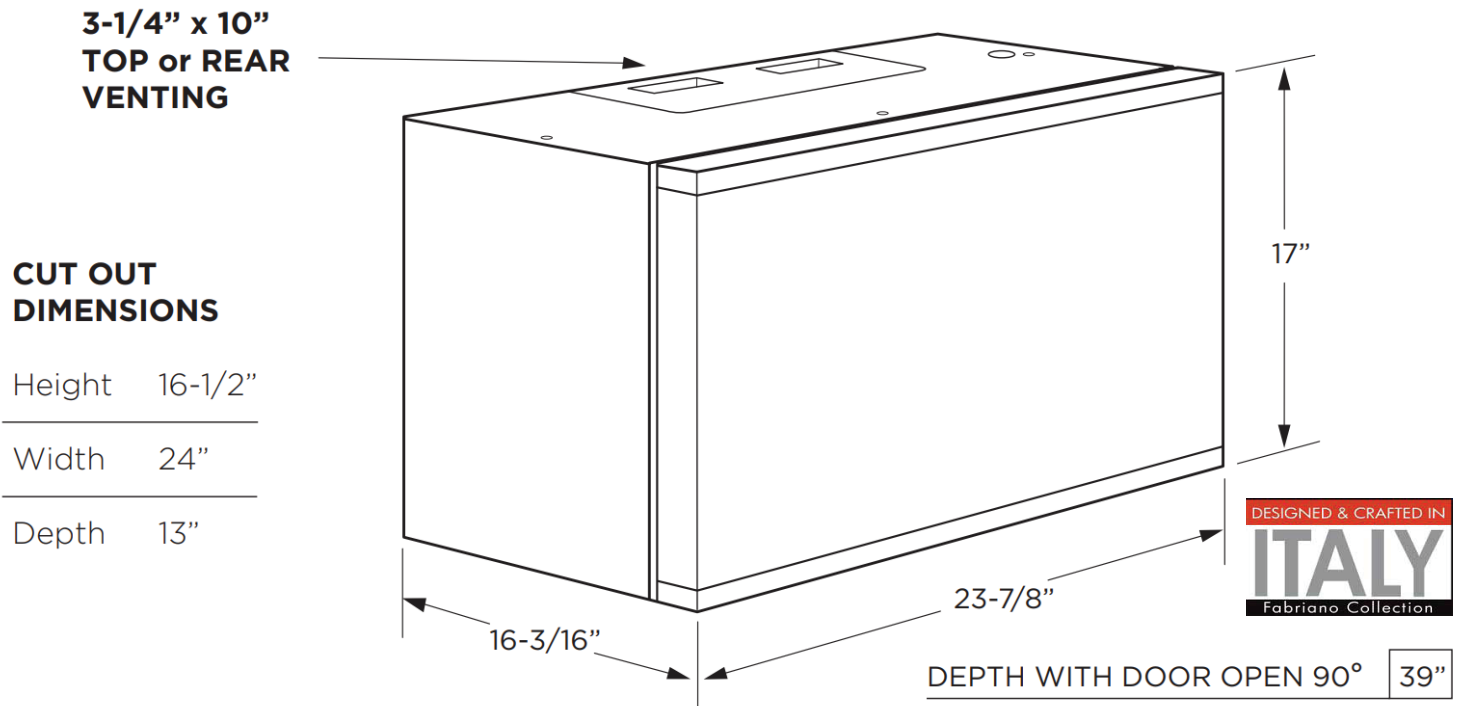

FEATURES

FINISH

Black Glass Door w Stainless Steel Trim
Integrated Handle
LED Clock
2 Level LED Lighting Illuminates Cooking Area

MICROWAVE

1000W | 1.34 cu ft Microwave
Touch Controls w 10 Power Levels
Pre-Programmed Control Options
Sensor Cooking and Auto-Defrost
13-5/8" Diameter Turntable w On/Off Feature

VENTILATION

2 Speed Blower 105 / 300 CFM (MUA Comp)
Recirculation Standard
Top/Rear Venting Option, Included (3-1/4" x 10")
Auto Start Heat Sensor
Dishwasher Safe Grease Filters
Carbon Filter for Recirculation, Included

PERFORMANCE

SPEED	1	2
CFM	105	300
SONES	1	5.5

SPECIFICATIONS

ELECTRICAL 120VAC 60HZ 13 AMP*

PWR CONNECTIONS RIGHT TOP REAR

OVEN INTERIOR WHITE

INTERIOR DIM

10-11/16" x 15-3/8" x 15-5/16"

SHIPPING WEIGHT 59 LBS

*dedicated 15 amp service required
unit must be properly grounded
see installation instructions

XO the next level
in luxury appliances

