

# INSTRUCTIONS

Modular Sofa

# CARTON A PART LIST

**A** Left Armrest

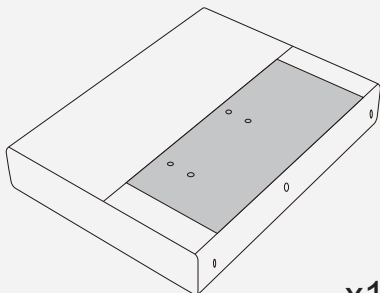

x1

**B** Right Armrest

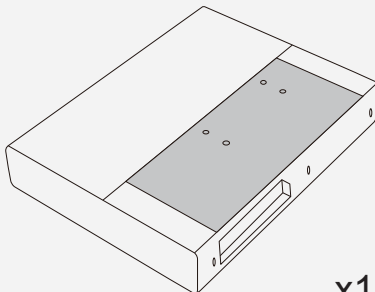

x1

**C** Plastic Leg

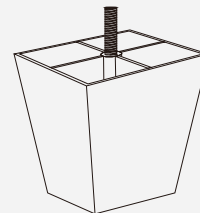

x4

**1** Plastic Washer

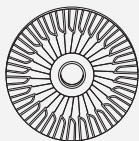

x4

**2** Armrest / Backrest Fitting

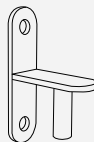

x4

**3** Screw



x10

# CARTON A PART LIST

4 Screwdriver

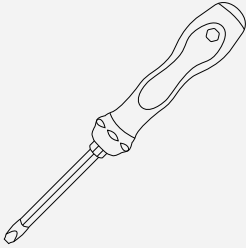

x1



**Step2:**

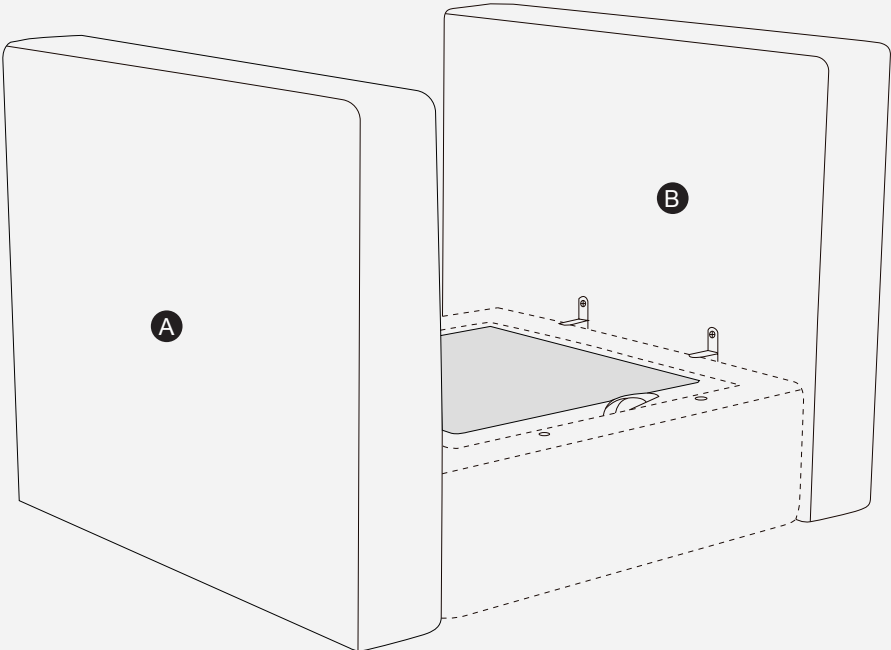

## Step4:

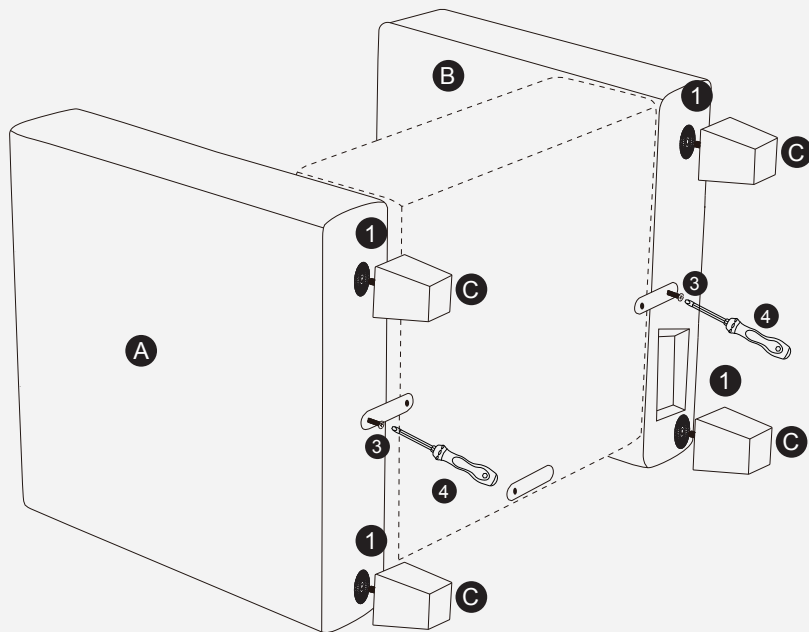

Please tighten the screws with screwdriver

## Step5:

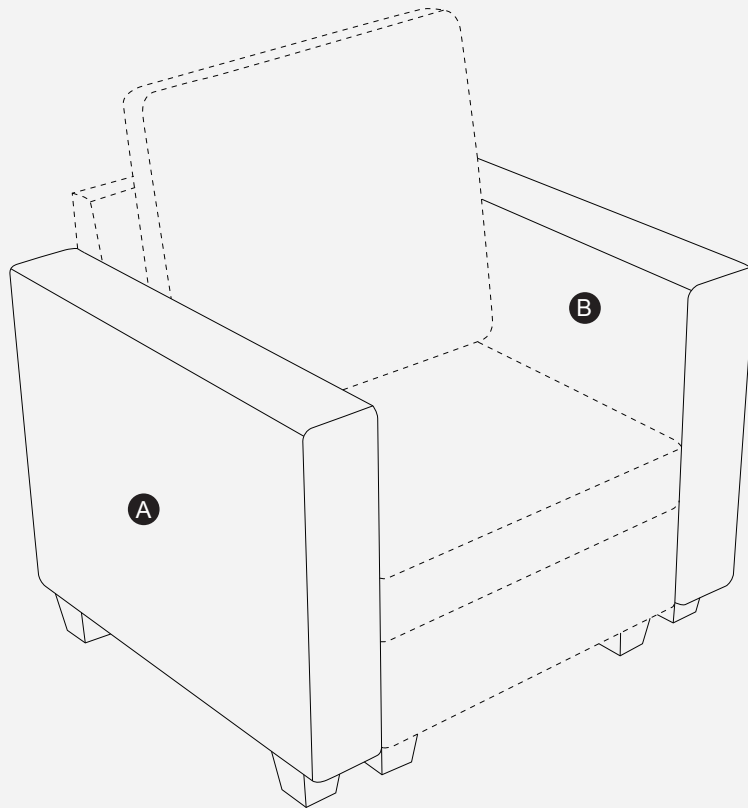

# CARTON B PART LIST

**D** Seat Frame

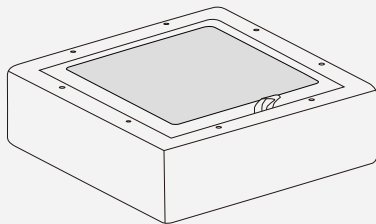

x1

**E** Backrest

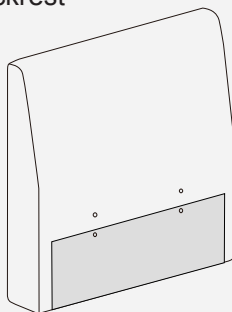

x1

**F** Seat Cushion

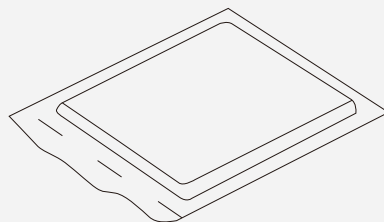

x1

**G** Pillow

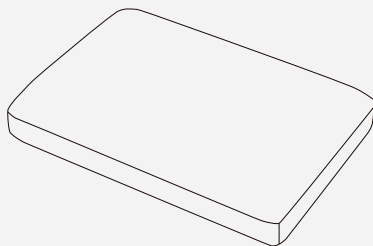

x1

**C** Plastic Leg

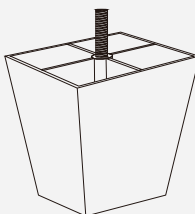

x5

**1** Plastic Washer

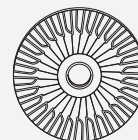

x5

# CARTON B PART LIST

## 2 Armrest / Backrest Fitting



x2

## 3 Screw



x6

## 5 Seat Fitting

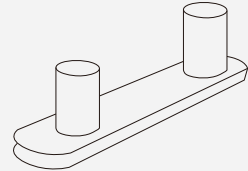

x2

## 6 Assembly Instructions

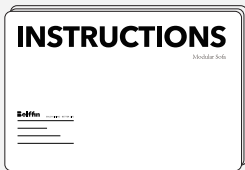

x1

# CARTON B ASSEMBLY

## Step1:

Seat frame and backrest are in carton B ,Remove all parts from the carton B, Place them on protected surface or carpet.

## Step2:

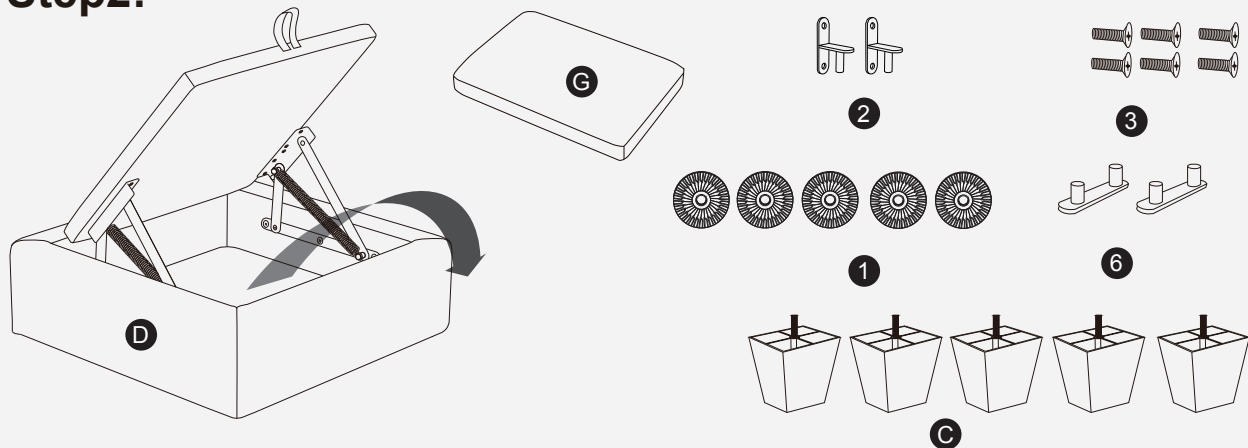

## Step3:

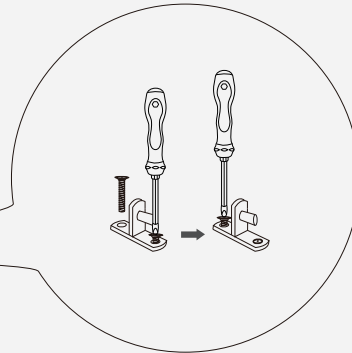
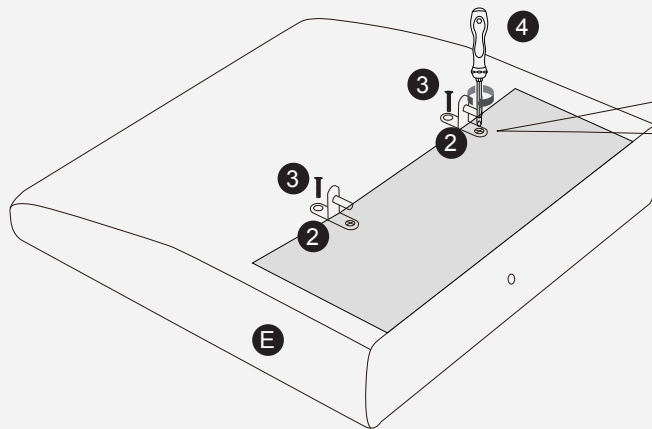

Please tighten the screws with screwdriver

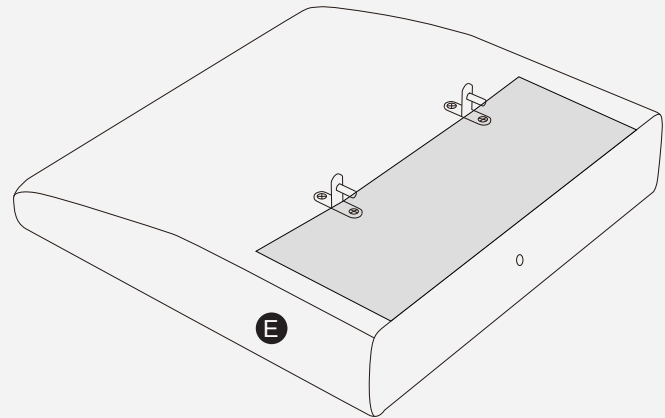

## Step4:

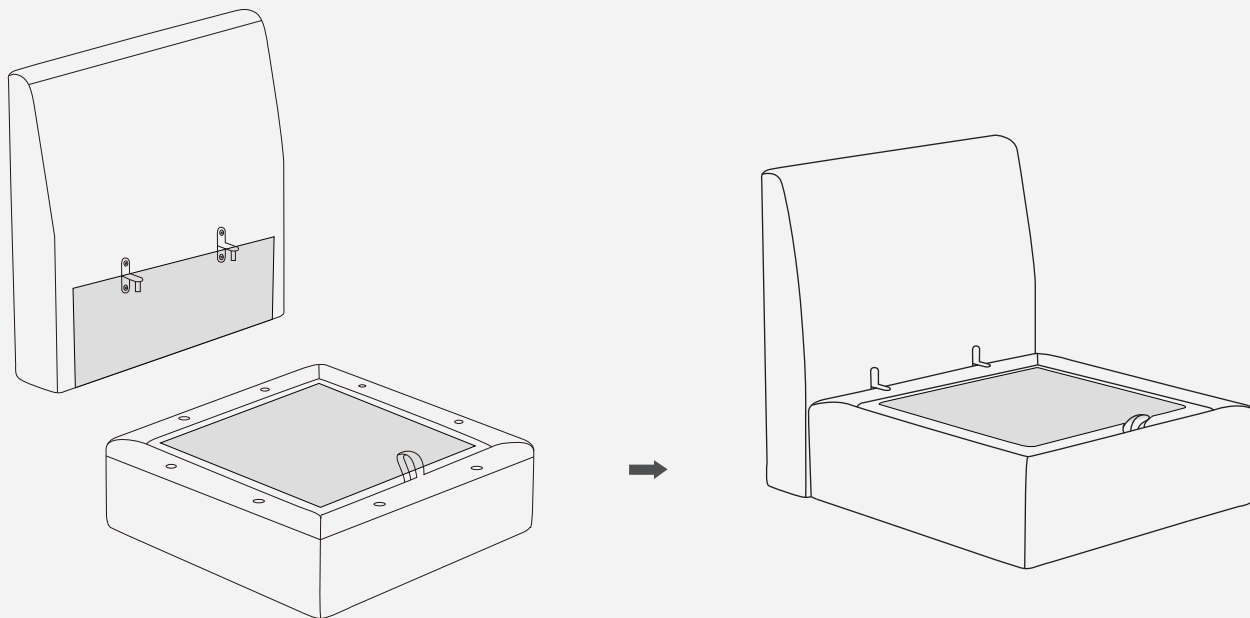

# Step5:

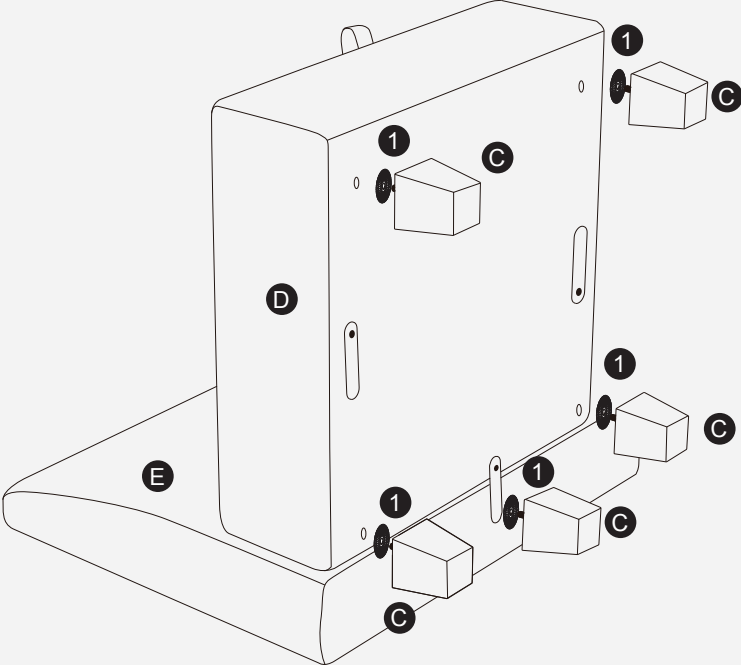

## Step6:

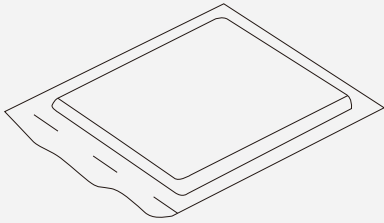

F

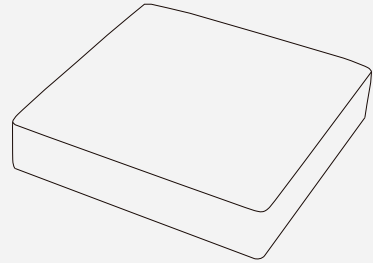

F

## Step7:

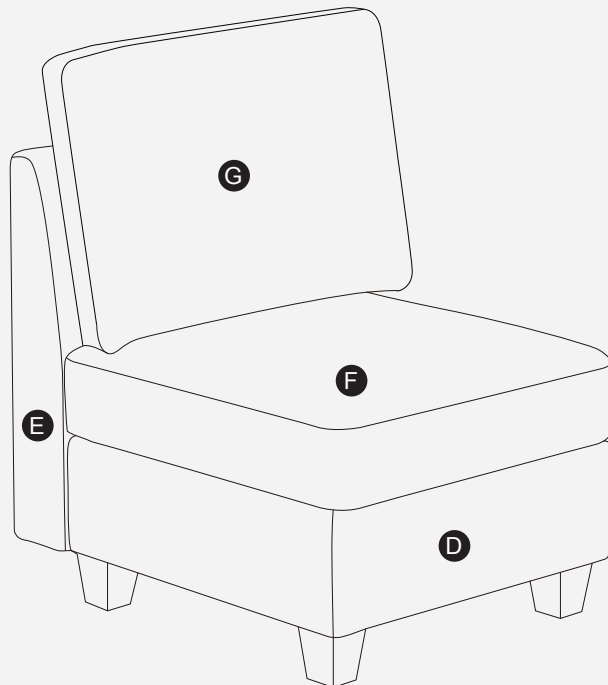

# CARTON C PART LIST

**D** Seat Frame

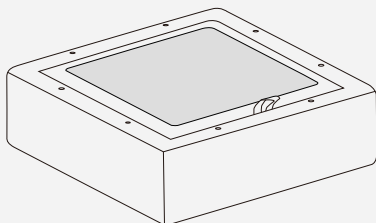

x1

**F** Seat Cushion

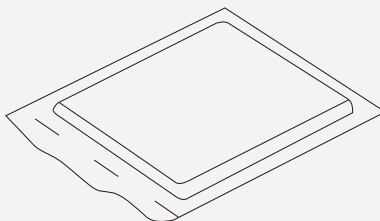

x1

**C** Plastic Leg

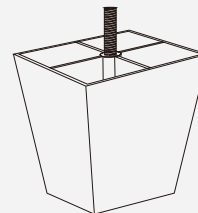

x4

**1** Plastic Washer

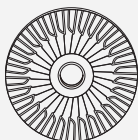

x4

**6** Seat Fitting

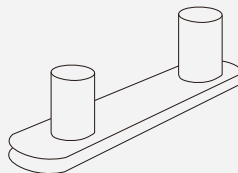

x2

# CARTON C ASSEMBLY

## Step1:

Seat frame is in carton C ,Remove all parts from the carton C , Place them on protected surface or carpet.

## Step2:

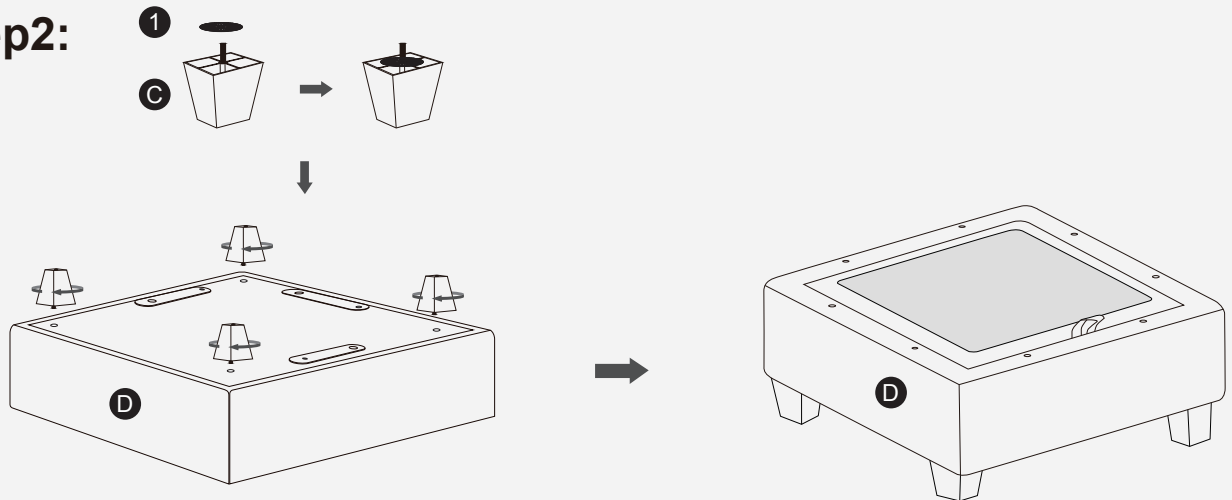

### Step3:

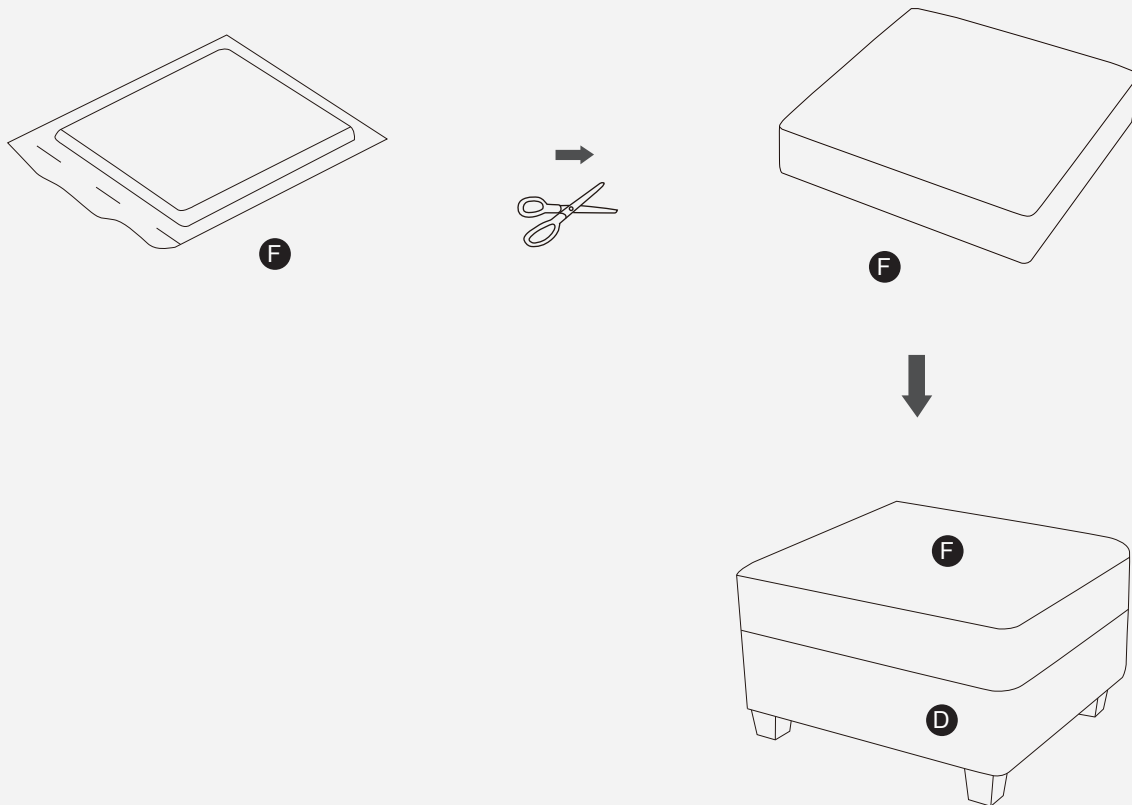

# Link Seat Frame and Seat Frame

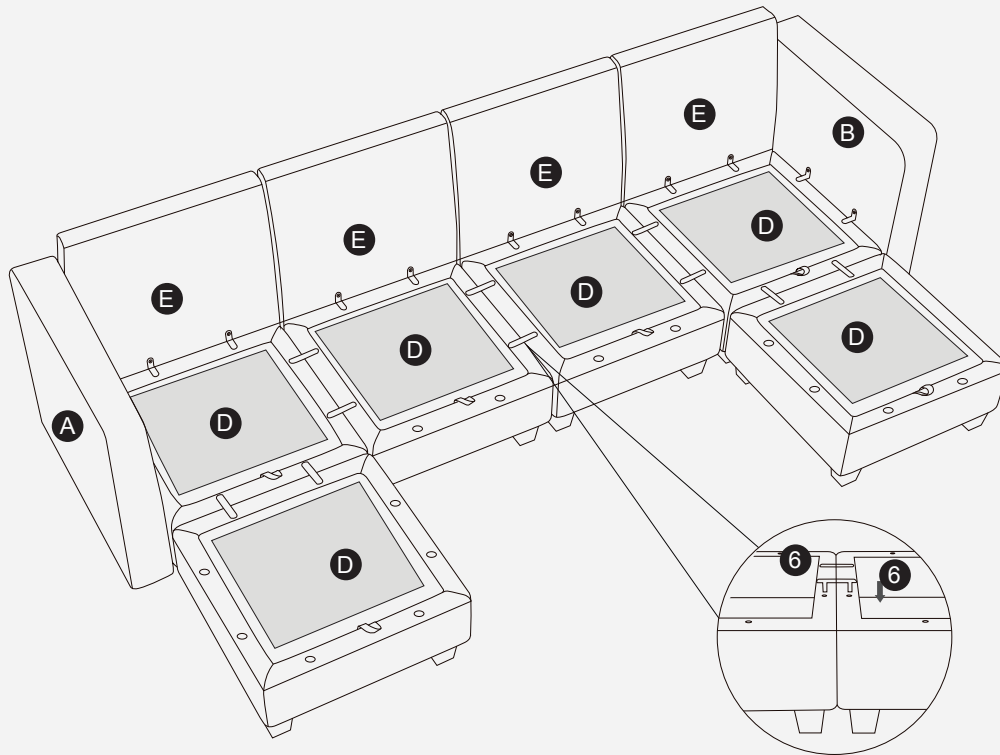

# Link Seat Frame and Seat Frame

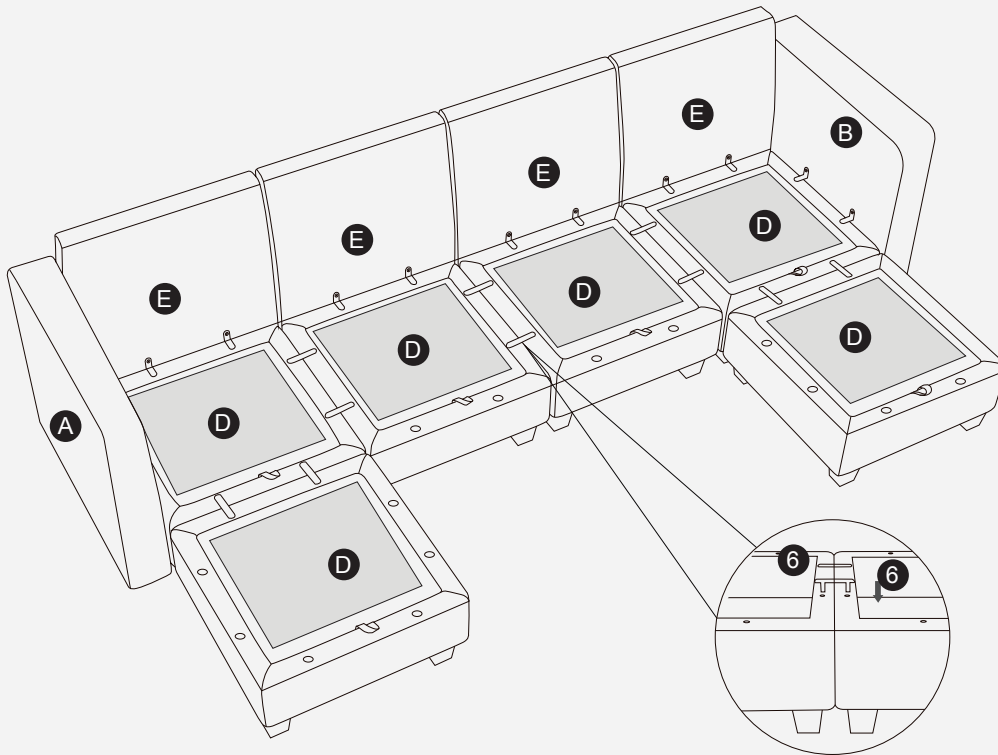

# FREE COMBINATION

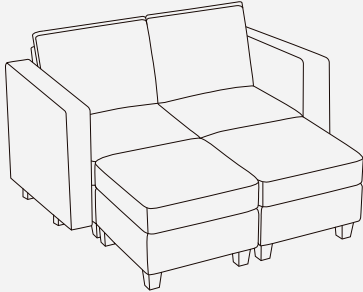

**Carton(4B)**

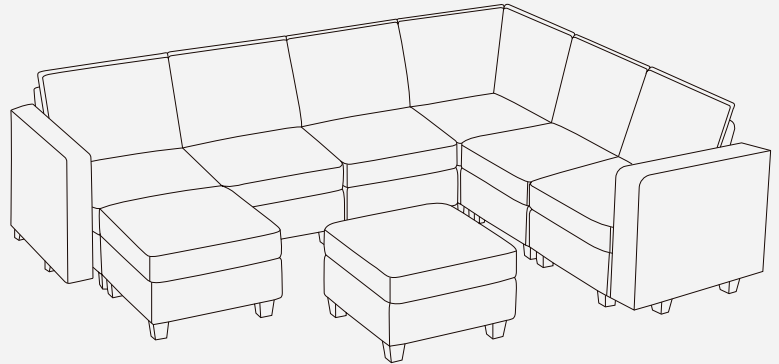

**Carton(A+7B+C)**