

INSTALLATION INSTRUCTIONS

MANUFACTURING QUALITY
CEILING FANS SINCE FOREVER.

Important: Please read and save these instructions before installation

Basic Product Specifications

Fan Blade Span	48"	Rated Wattage	44W (Fan 26W / Lamp 18W)
Gross Weight	16 lbs.	Motor RPM	115-230 RPM
Maximum Airflow	3860 CFM	Maximum Noise	55 dB(A)

Fan Blade Span	52"	Rated Wattage	42W (Fan 24W / Lamp 18W)
Gross Weight	17 lbs.	Motor RPM	65-200 RPM
Maximum Airflow	4360 CFM	Maximum Noise	55 dB(A)

This Ceiling Fan is :



Variable Speed Options



Forward / Reverse
Fan Direction

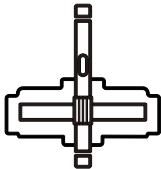

DC Motor, stable & silent,
suitable for indoor use



Built with premium materials
for durability & power



Pull Chain Control

SAFETY PRECAUTIONS

READ AND SAVE THESE INSTRUCTIONS

- Before you begin installing the fan, shut power off at the circuit breaker of the fuse box.
- Make sure that all electrical connections are in accordance with National Electrical Code, ANSI/NFPA 70 and local codes. Hire a licensed electrician if you are unfamiliar with installing electrical wiring.
- Make sure the installation site you choose allows the fan blades to rotate without any obstructions. Allow a minimum clearance of 2.1m (7 feet) from the floor and 18 inches from the tip of the blades to the wall.
- The outlet box and support structure must be securely mounted and capable of reliably supporting a minimum of 35 pounds. Use only U.L. listed outlet boxes marked "Acceptable for Fan Support of 15.9 kg (35 lbs) or less".
- Before and after you install the fan, make sure that all mounting components are secured to prevent the fan from falling.
- Do not insert anything into the fan blades while the fan is operating.
- To change the direction of the rotation of the blades, the fan must be in operation mode.
- All screws must be checked and retightened where necessary before installation.
- After making the wire connections, the wires should be spread apart with the grounded conductor and the equipment-grounding conductor on one side of the outlet box and the ungrounded conductor on the other side of the outlet box.
- The splices after being made should be turned upward and pushed carefully up into the outlet box. Conductor wiring identified as grounded is to be connected to a grounded conductor of power supply. Conductor wiring identified as ungrounded conductor is to be connected to an ungrounded conductor. Conductor wiring identified for equipment grounding is to be connected to an equipment- grounding conductor.
- This device complies with part 15 of the FCC Rules. Operation is subject to the following two conditions: (1) This device may not cause harmful interference, and (2) this device must accept any interference received, including interference that may cause undesired operation.

SAFETY PRECAUTIONS

- **CAUTION:** Read all instructions and safety information before installing your new fan. Review accompanying assembly diagrams.
- **WARNING:** Mount only to an outlet box marked acceptable for fan support.
AVERTISSEMENT: Assembler uniquement à une boîte de sortie jugée acceptable pour retenir un ventilateur.
- **WARNING:** To reduce the risk of fire, electric shock, or personal injury, mount to a structural framing member or to an outlet box marked acceptable for fan support of 15.9 kg (35 lbs) or less. For outlet box mounting, use mounting screws provided with the outlet box.
AVERTISSEMENT: Afin de réduire les risques d'incendie, de choc électrique ou de blessures corporelles, ils doivent être montés sur des éléments de charpente structurale ou sur des boîtes de sortie marquées d'un support de ventilateur acceptable de 15,9 kg (35 LB) ou moins. Pour l'installation de la boîte de sortie, utilisez les vis de montage fournies avec la boîte de sortie”
- **CAUTION:** To reduce the risk of injury, use only the screws provided with the outlet box in conjunction with the lock washers.
- **WARNING:** To reduce the risk of personal injury, do not bend the blade bracket when installing the brackets, balancing the blades, or cleaning the fan. Do not insert foreign objects in between rotating fan blades.
- **CAUTION:** To reduce the risk of electric shock, disconnect the electrical supply circuit to the fan before installing the light kit.
- **WARNING:** To reduce the risk of fire or electric shock, this fan must be installed with a general use, non-dimmable, single gang, isolating wall control/switch.
- **WARNING:** To reduce the risk of fire or electric shock, do not use this fan with any solid-state speed control device.
AVERTISSEMENT: Ne convient pas à des régulateurs de vitesse à semi-conducteurs.
- **NOTE:** The important safeguards and instructions appearing in this manual are not meant to cover all possible conditions and situations that may occur. It must be understood that common sense, caution and care are factors which cannot be built into this product. These factors must be supplied by the person(s) installing, caring for and operating the unit.
- **CAUTION:** The light source is designed for this specific application and can overheat if serviced by untrained personnel. If any servicing is required, the product should be returned to an authorized service facility for examination or repair.
- **WARNING:** Do not use corrosive detergents for cleaning.
- **WARNING:** To reduce the risk of fire, electric shock, or injury to persons, do not use replacement parts that have not been recommended by the manufacturer. (e.g. Parts made at home using a 3D printer).
- **NOTE:** Before installing the fan, please check and inspect all of the fan components and make sure they have all been received in good condition. Contact the manufacturer if there are any missing, damaged, or broken parts.

Table of Contents

06	Fan Diagram
08	Disassembly
10	Fan Blades
11	Light Kit Pan & Light Kit
12	Mounting Options
13	Hanging
14	Safety Rope
15	Wiring
16	Securing the Fan
17	Lampshade / Power On
18	Operation
19	Troubleshooting
20	Care & Cleaning / FCC

Fan Diagram

Before installing, please check to make sure you have received all the necessary components for installation. Some extra hardware may also have been included.

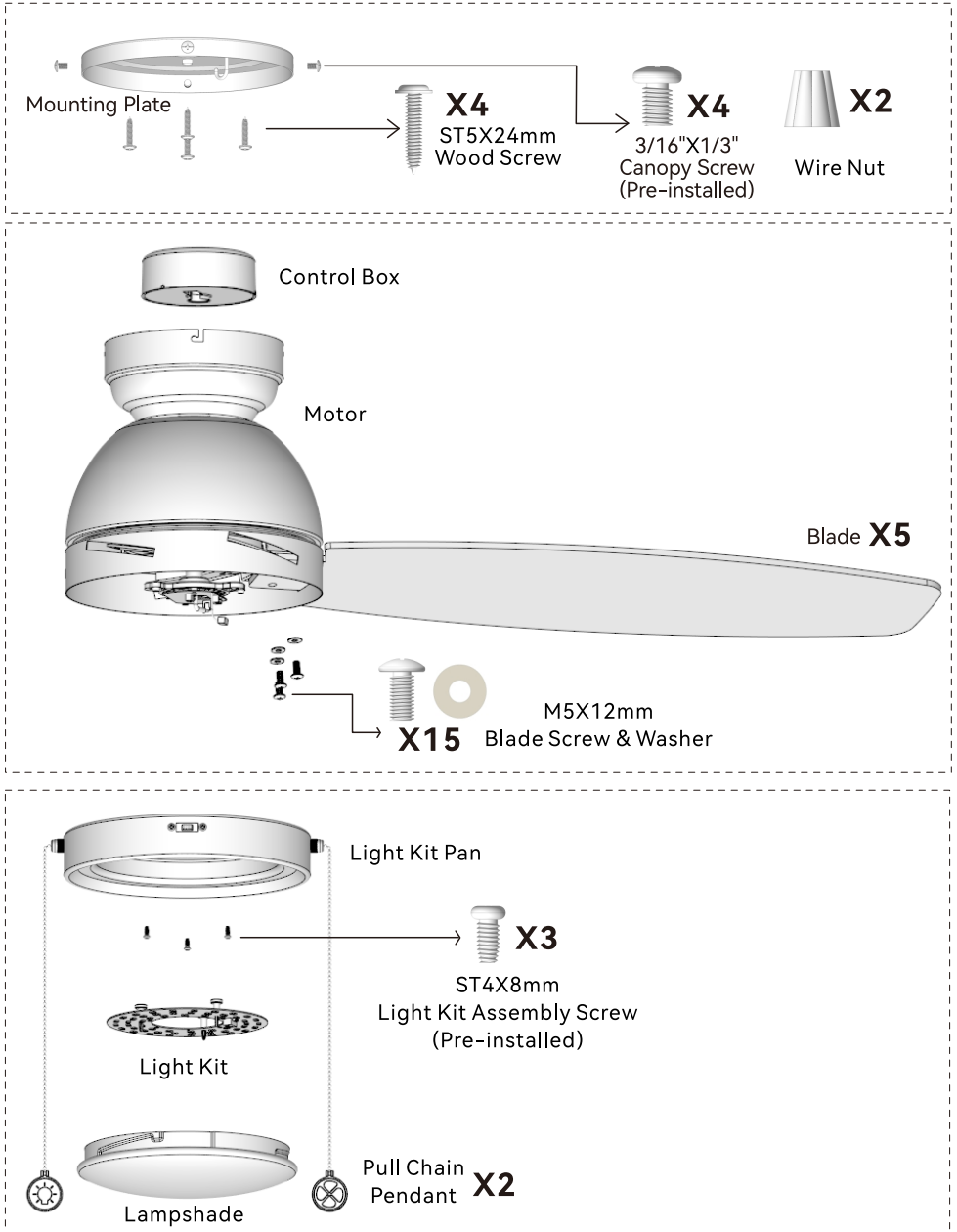

Installation

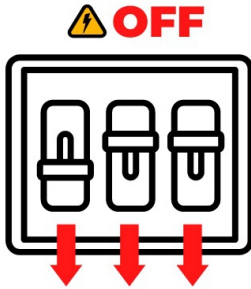

WARNING: To avoid serious injury or death, turn off the power at the circuit breaker before installing the fan.

Tools you'll need



Phillips
screwdriver



Step ladder

Installation: Disassembly

1. Disassemble the Light Kit

1.1 Take the motor assembly out of the box and detach the light kit by pulling it away from the assembly. The light kit is attached to the assembly by magnets.

1.2 Unscrew the three pre-installed light kit assembly screws that attach the light kit pan to the PCB board of the motor assembly. Rotate the light kit pan and remove it from the assembly. Save the screws for later use.

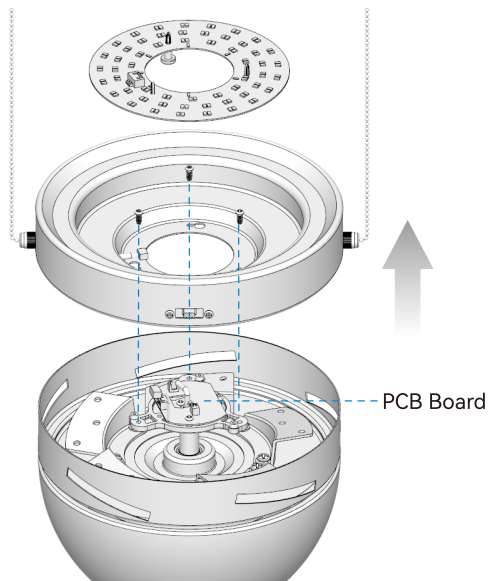

Fig. 1.1



X3

ST4X8mm

Light Kit Assembly Screw

Installation

1.2 Utilize a screwdriver to remove the two canopy screws situated in the single holes. Subsequently, gently loosen the other two canopy screws positioned in the L-shaped holes.

Proceed by rotating the mounting plate to align it with the designated notch, and then pull to detach the mounting plate. Remember to retain the screws for later use.

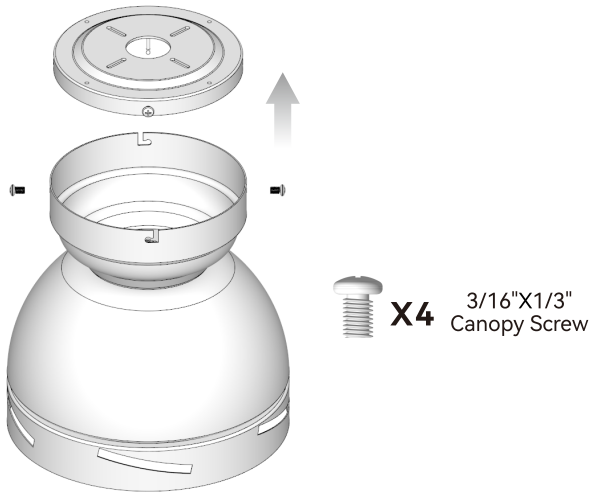

Fig. 1.2

Installation: Fan Blades

2. Install the Fan Blades

Find the 15 blade attachment screws and washers in the hardware pack. Slide the blades through the center band of the motor housing and align the holes. Use the blade screws and washers to securely attach the blades in place.

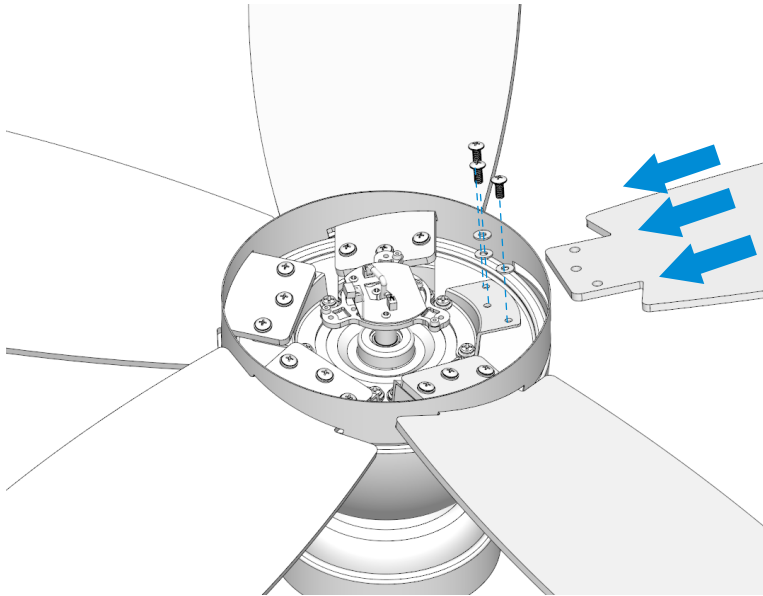

Fig. 2.1



Installation: Light Kit Pan & Light Kit

3. Install the Light Kit Pan & Light Kit

3.1 Connect the male plug **(a)** from the light kit pan to the female terminal block **(b)** on the PCB board as shown in Fig. 3.1.

3.2 Thread the wire plug **(c)** from the PCB board through the center hole of the light kit pan. Attach the light kit pan to the PCB board of the motor housing.

3.3 Align the light kit pan with the PCB board. Reinstall the three light kit assembly screws that were removed in step 1. Make sure all screws are securely tightened.

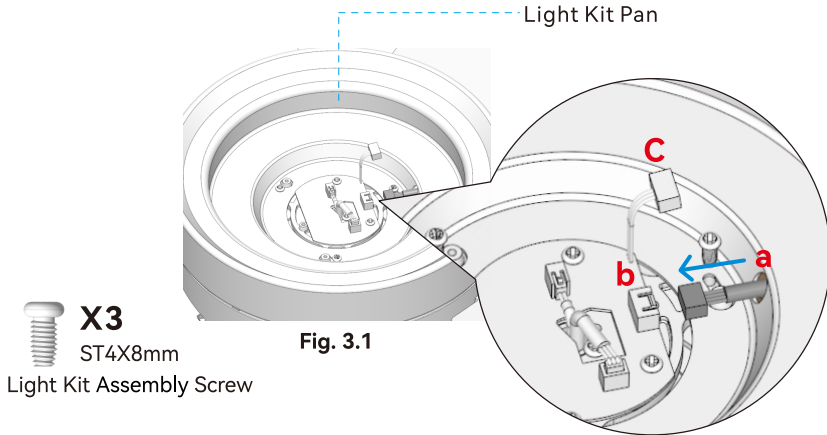

3.4 Allow the wire plug **(c)** to pass through the light kit. Reinstall the light kit. The light kit will be magnetically attracted to the pan with the help of magnets.

3.5 Insert the wire plug **(c)** into the light kit terminal block **(d)** on the light kit as shown in Fig. 3.2.

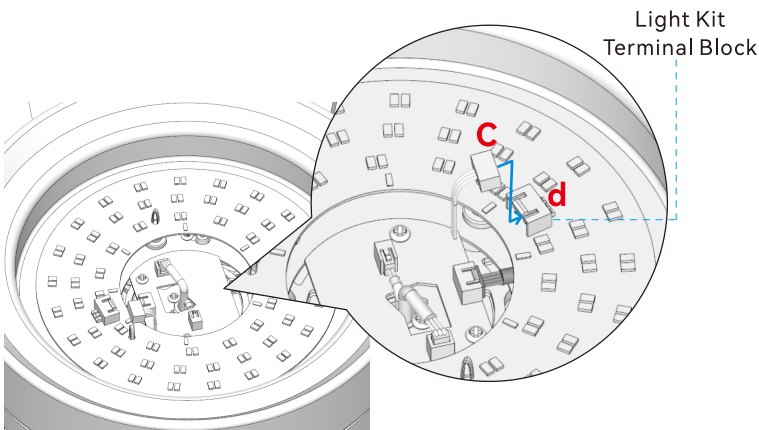

Installation: Mounting Options

4. Install the Mounting Plate

You have two options for the mounting plate installation. Choose the one that works best for your location.

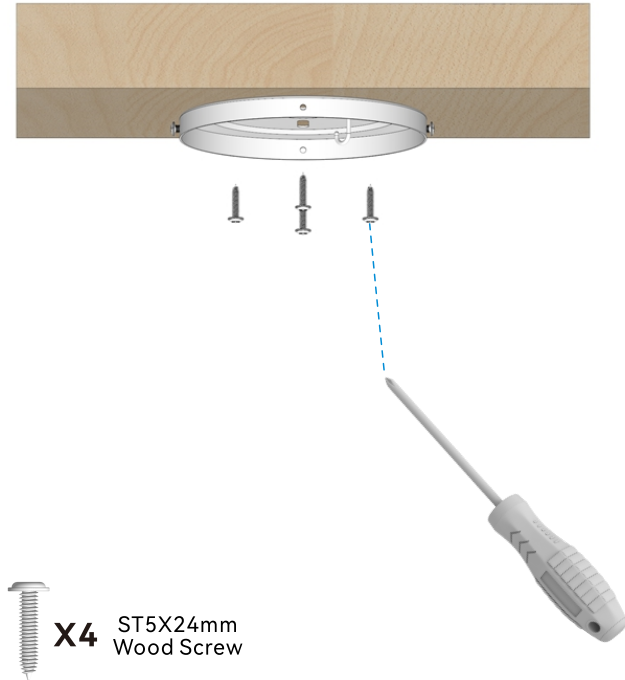

Fig. 4.1

Installation: Hanging

WARNING: Before beginning, make sure to turn off the power from the circuit breaker !

Note: For optimal fan performance, ensure that the mounting plate is level.

Option 1: Secure the mounting plate to a wooden ceiling beam or support structure with an approved electrical outlet box using the ST5x24mm wood screws (included) as shown in Fig. 4.1.

Option 2: Use machine screws (provided with outlet box) and washers to attach the mounting plate to an existing ceiling fan-rated outlet box. If the mounting plate is installed at the outlet box, it should be installed on the outlet box with the screws that came with your outlet box. Pull the supply wires (the black, white, and ground wires) out of the outlet box and through the hole in the mounting plate, then set them aside.

WARNING: DO NOT use a plastic outlet box. Use only U.L. listed outlet boxes marked "Acceptable for Fan Support of 15.9 kg (35 lbs) or less".

5. Hang the Fan

5.1 Carefully lift the fan-motor assembly and hang it using the hook of the mounting plate. Securely suspend the motor assembly by using one of the round holes at the outer rim of the motor housing as shown in Fig. 5.1.

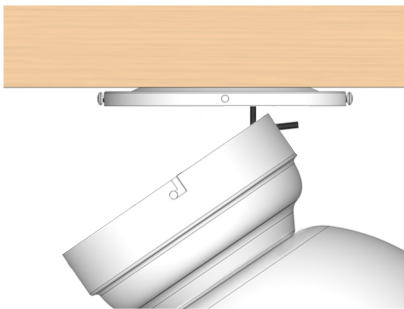

Fig. 5.1

⚠ WARNING

Hazard of Fan Falling! Ensure the circular hole on the outer edge of the motor housing is fully engaged with the hook on the mounting plate to securely hang the fan motor assembly.

A warning icon consisting of a black silhouette of a ceiling fan falling from above, with a red arrow pointing downwards towards a black silhouette of a person standing below. The entire icon is enclosed in a rounded rectangular border.

Installation: Safety Rope

5.2 There are multiple methods to install the safety rope; here are two options for your reference.

Option 1: Refer to Fig. 5.2. Hang the safety rope on the ceiling hook (not included). Using a screwdriver, loosen the screw on the safety rope lock. Pull the safety rope taut and then tighten the screw on the safety rope lock to ensure a firm and secure connection between the safety rope and the ceiling hook. Always double-check to ensure the safety rope is taut.

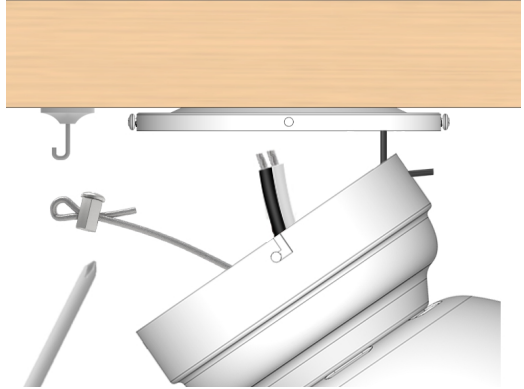

Fig. 5.2

Option 2: Refer to Fig. 5.3. Thread a screw, accompanied by a washer (both not included), through the center of the safety rope. Fasten the screw to the ceiling and then loosen the screw on the safety rope lock using a screwdriver. Pull the safety rope taut and then tighten the screw on the safety rope lock to securely anchor the safety rope to the fixed screw on the ceiling. Always double-check to ensure the safety rope is taut.

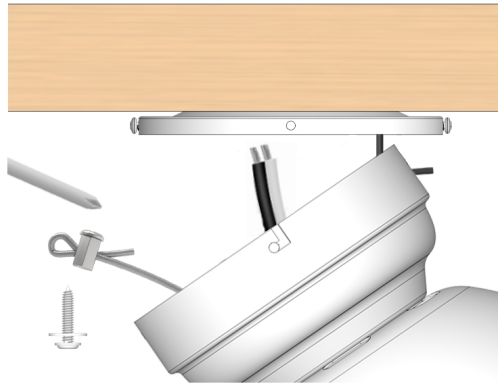

Fig. 5.3

Note: Installing the ceiling fan with a safety rope is an extra safety feature. It secures the fan to the ceiling hook or other attachment point and prevents the fan from falling even in the case of material failure.

When the safety rope is fixed and installed, it is important to adjust both the length of the wire rope and the screw on the safety rope lock to ensure a secure and tight connection with the fixed object. This step is crucial to prevent the safety rope from accidentally coming off. Improper installation of the safety rope may compromise its effectiveness and lead to potential safety risks. Therefore, it is essential to make sure the safety rope is properly tightened and secured for maximum safety.

Installation: Wiring

6. Connect the Wiring

Connect the Green/Yellow wire from the mounting plate to the supply Ground wire using a wire nut.

Connect the White wire from the motor to the supply White (Neutral) wire using a wire nut. Connect the Black wire from the motor to the supply Black/Red (Hot/Live) wire using a wire nut.

Make sure all the wires are connected to the correct colors as shown in Fig. 6.1. Then, hide the wiring inside the motor housing.

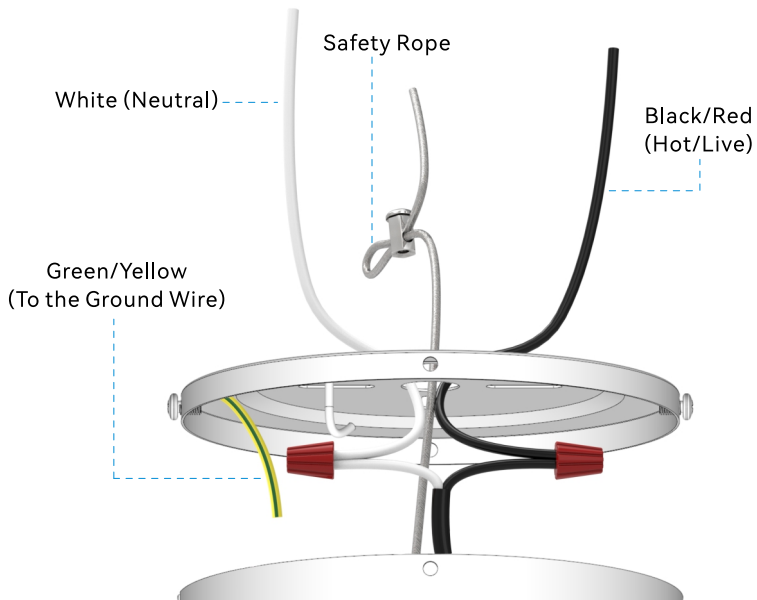

Fig. 6.1

Installation: Securing the Fan

7. Secure the Fan

With both hands, gently lift the fan body off of the hook. Ensure that the hook does not interfere with the wires.

Align the L-shaped holes on both sides of the fan body with the two loosened canopy screws on the mounting plate. Slide the two slots on both sides of the fan body between the heads of the screws, and then rotate the fan body to ensure the screws hold the fan body firmly in place.

Reinstall the other two canopy screws that were previously removed into the single holes. Tighten all four screws securely.

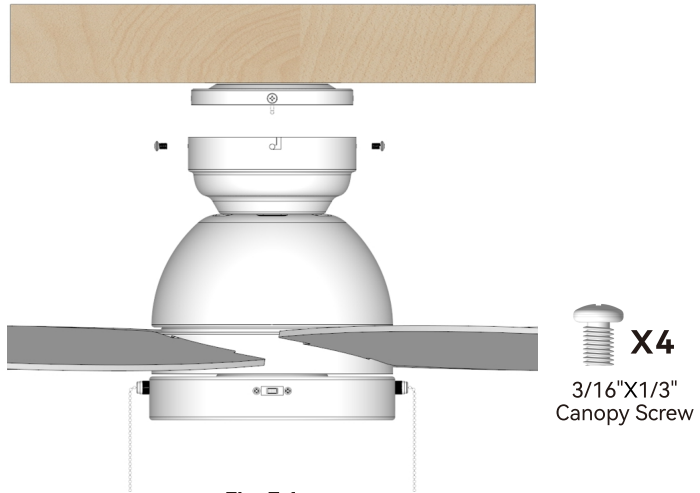

Fig. 7.1



Installation: Lampshade / Power On

8. Install the Lampshade

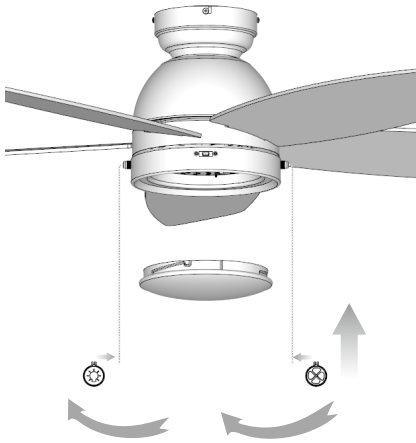

Fig. 8.1

Align the slots of the lampshade with the slots of the light kit pan, and turn the lampshade clockwise to securely lock it into place, as shown in Fig. 8.1.

Attach the decorative pull chain pendants to the chains coming out of the switch cover.

Note: Do not over tighten the lampshade.

⚠ WARNING

To prevent **SERIOUS INJURY** or **DEATH**, make sure that the lampshade is properly secured. Allow the lampshade to cool completely before attempting to remove it.



9. Power On

At this time, the ceiling fan has been installed. Turn on the power supply from the circuit breaker of the main switch or the room where the ceiling fan is installed. Once the power is on, check to see if the fan light is illuminated.

Note: Please be aware that this ceiling fan may produce noticeable operating sounds at specific wind speeds. This is a normal operating characteristic and does not indicate any issues with its functionality.

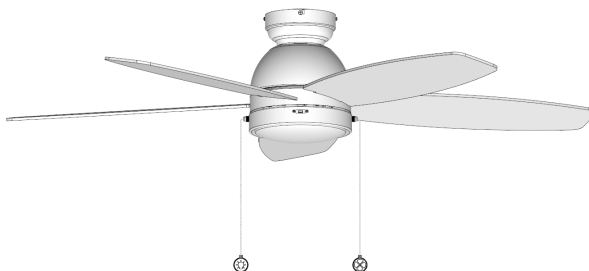

Operation

Turn on the power and check the operation of your fan.

The fan pull chain controls the fan speed settings:

- 1 pull= (Low Speed)
- 2 pulls= (Medium Speed)
- 3 pulls= (High Speed)
- 4 pulls= Fan Off

The light pull chain controls the light brightness:

Upon powering on, the light defaults to 50% brightness

- 1 pull= (100% Brightness)
- 2 pulls= (10% Brightness)
- 3 pulls= (50% Brightness)

After turning on the light, pull the light pull chain within 5 seconds to cycle through the 3 brightness settings: 100%, 10% and 50%. The light will remember the last used setting due to its memory function.

If no further action is taken within 5 seconds after turning on the light, pulling the chain again will turn the light off.

Power-Off Memory Function

If the fan is running and there is a sudden power outage, the fan and light will automatically resume operation at the last used settings when power is restored due to the power-off memory function, unless there is subsequent user intervention.

Forward and reverse direction function

Forward function

When set to this function, the fan will rotate counterclockwise to create a cooling effect. This function is recommended during warmer weather to circulate the hot air away from your living space.

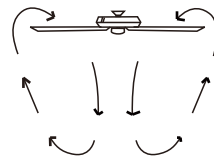

Reverse function

When set to this function, the fan will rotate clockwise. Use this function during cooler weather to recirculate warm air and distribute it evenly throughout the room.

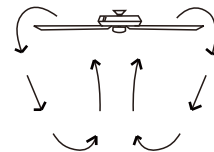

Troubleshooting

Try these troubleshooting steps before contacting Customer Service. For additional operation, maintenance, and troubleshooting information, please contact our customer service center.

SYMPTOM	POSSIBLE SOLUTION
Fan not spinning	<p>① Make sure the fan is getting power. ② Check your circuit breaker or fuse panel and wall switch for functionality. ③ Check to make sure the fan wires are correctly connected to the house wires. ④ Use a multi-meter and test the wiring harness to see if there is any electrical output. ⑤ All the pin wiring on the circuit board must be inserted tight and in the correct position. ⑥ Make sure the fan blades spin freely. ⑦ If you're using a wall control, check the power to the breaker from your control and try working your ceiling fan manually. (Normal switch only for the fan power on/off)</p>
Fan light not working	<p>① Make sure LED wires are connected to the circuit board. ② Make sure the whole fan is powered.</p>
The fan is noisy and wobbling	<p>① Check if the blade screws are NOT rubbing against any part of the motor housing. ② Check the pin wires are NOT connected against any moving parts. ③ Check the down fan cup is NOT hitting the motor. ④ Confirm the canopy is NOT touching the ceiling while the fan is in operation. ⑤ Check the down rod is NOT slanted. ⑥ Tighten any loose screws on the light kit, fan blades, motor coupling, down rod, brackets and mounting hardware. ⑦ Confirm the hanger ball is firmly seated in the mounting bracket. ⑧ The ceiling beam must meet the minimum tensile test strength of 30kg for installation. ⑨ Make sure the blades and brackets are NOT bent or deformed. ⑩ Verify the wire connections are not rattling against each other. ⑪ Verify the fan blades are not cracked. If the fan blades are cracked, replace the damaged blades with a new blade set from the same brand as your ceiling fan to ensure compatibility. ⑫ Confirm the light kit is NOT slanting and hitting the motor.</p>
Fan or light turning on or off by themselves	<p>① Confirm the circuit breaker is not malfunctioning. ② Verify the wire connections are not frayed. ③ Cut the fan power for 10 minutes then power on again. ④ All the pin wiring on the circuit board must be inserted tight and in the correct position.</p>

Care & Cleaning

WARNING: Power off the fan before performing maintenance or cleaning the fan.

1. Check the support connections, brackets, and blade attachments twice a year. Make sure they are secure. Because of the fan's natural movement, some connections may become loose over time. It is not necessary to remove the fan from the ceiling.
2. Clean your fan periodically. Use only a soft brush or lint-free cloth to avoid scratching the finish. The plating is sealed with a lacquer to minimize discoloration or tarnishing.
3. (Optional) Apply a light coat of furniture polish to the wood blades.
4. (Optional) Cover small scratches with a light application of shoe polish.

DO NOT:

1. Use water when cleaning. Water could damage the motor, or the wood, or possibly cause an electrical shock.
2. Apply oil to your fan or motor. The motor has permanently lubricated sealed ball bearings.

FCC Statement

Note: This equipment has been tested and found to comply with the limits for a Class B digital device, pursuant to part 15 of the FCC Rules. These limits are designed to provide reasonable protection against harmful interference in a residential installation. This equipment generates, uses and can radiate radio frequency energy and, if not installed and used in accordance with the instructions, may cause harmful interference to radio communications. However, there is no guarantee that interference will not occur in a particular installation. If this equipment does cause harmful interference to radio or television reception, which can be determined by turning the equipment off and on, the user is encouraged to try to correct the interference by one or more of the following measures:

- Reorient or relocate the receiving antenna.
- Increase the separation between the equipment and receiver.
- Connect the equipment into an outlet on a circuit different from that to which the receiver is connected.
- Consult the dealer or an experienced radio/TV technician for help.

WARNING: Changes or modifications to this unit not expressly approved by the party responsible for compliance could void the user's authority to operate the equipment.

WARRANTY

Limited Lifetime Warranty

We grant this limited warranty to the original purchaser of this ceiling fan for the original installation location.

How Can Warranty Service Be Obtained?

Warranty registration is not necessary to obtain warranty service. Please keep a copy of your original purchase receipt from the authorized vendor where your product was purchased from and provide it to a service associate for warranty service. At our sole discretion, may accept a gift receipt. Please do not ship your fan or any fan parts to us unless approved by one of our Technical Support Representatives. To obtain service, please contact us online or by phone.

What Does This Warranty Cover ?

Motor: Three-Year Warranty

If any part of your ceiling fan motor fails within the first year due to a manufacturing defect as determined solely by us, we will provide you with replacement parts free of cost. After the first year of purchase, we will provide you with two-year motor warranty service.

LED Kit: Three-Year Warranty

If your LED light kit (excluding cover) fails at any time within three years of the date of purchase due to a manufacturing defect as determined solely by us, we will provide a free replacement.

Other: Three-Year Warranty

Except as otherwise indicated throughout this warranty, if any part of your ceiling fan fails at any time within three year of the date of purchase due to a manufacturing defect as determined solely by us, we will provide a free replacement part.

What Does This Warranty NOT Cover ?

Labor Excluded: This warranty does not cover any costs or fees associated with labor (including electrician's fees) required to install, remove, or replace a fan or any fan parts.

The warranty does not cover remote control batteries. Fans installed outside the United States or owned by someone other than the original purchaser are excluded from warranty coverage. The warranty will be invalid if the customer fails to establish proof of purchase or if the fan was purchased from an unauthorized dealer.

The warranty does not cover normal wear and tear or cosmetic damages. If the fan is damaged due to improper installation, misuse, improper care, modifications to the fan, improper or incorrectly performed maintenance or repair, improper voltage supply or power surge, use of improper parts or accessories, failure to provide maintenance to the fan, or natural disasters (e.g. flood), the warranty will not cover it. The warranty also does not cover any accidental damages.

The warranty only applies to the original purchase and starts from the original purchase date. Any replacements will be considered as a part of the original purchase.