

# ASSEMBLY HANDBOOK – FORTRESS GARAGE TABLE

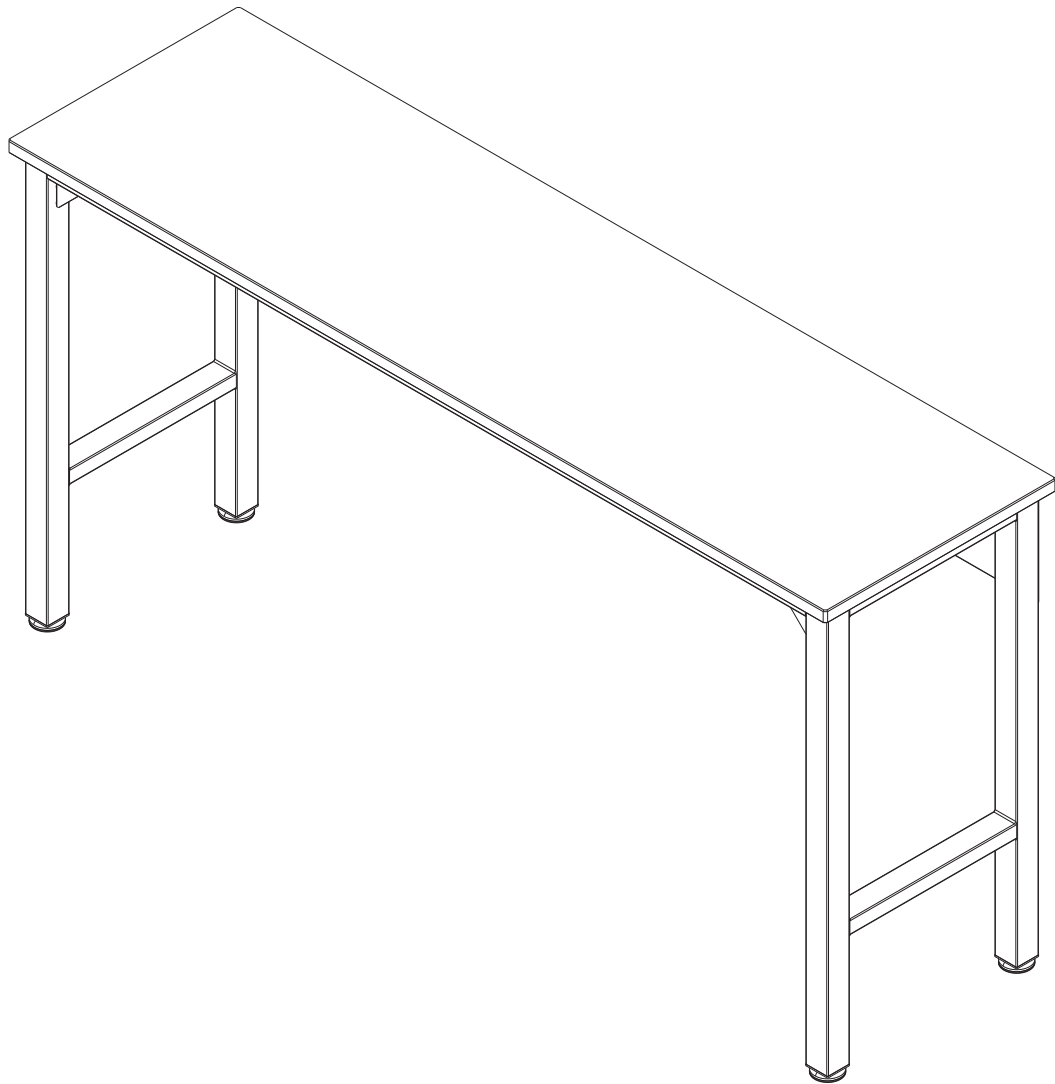

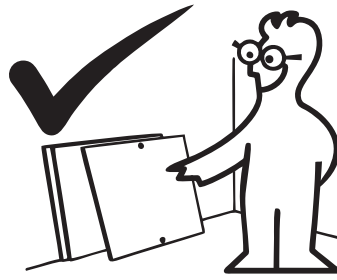
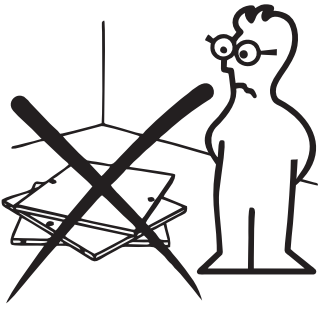

In order to ease the assembly, you should separate and identify the parts first

### Necessary hardware for the assembly

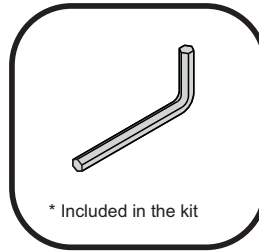
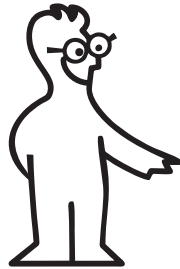

\* Included in the kit

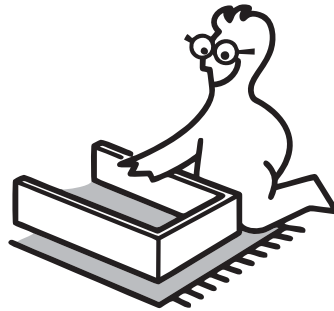
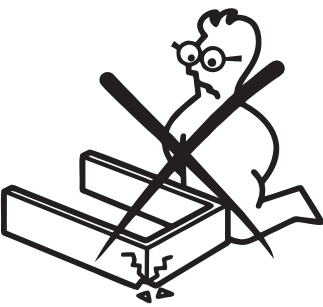

Do not place the parts directly onto the floor. Use a cardboard sheet or a mat to place the parts, during the separation and assembly.

### IMPORTANT

In order to avoid severe or even fatal injuries, follow the instructions carefully.

# ASSEMBLY HANDBOOK – FORTRESS GARAGE TABLE

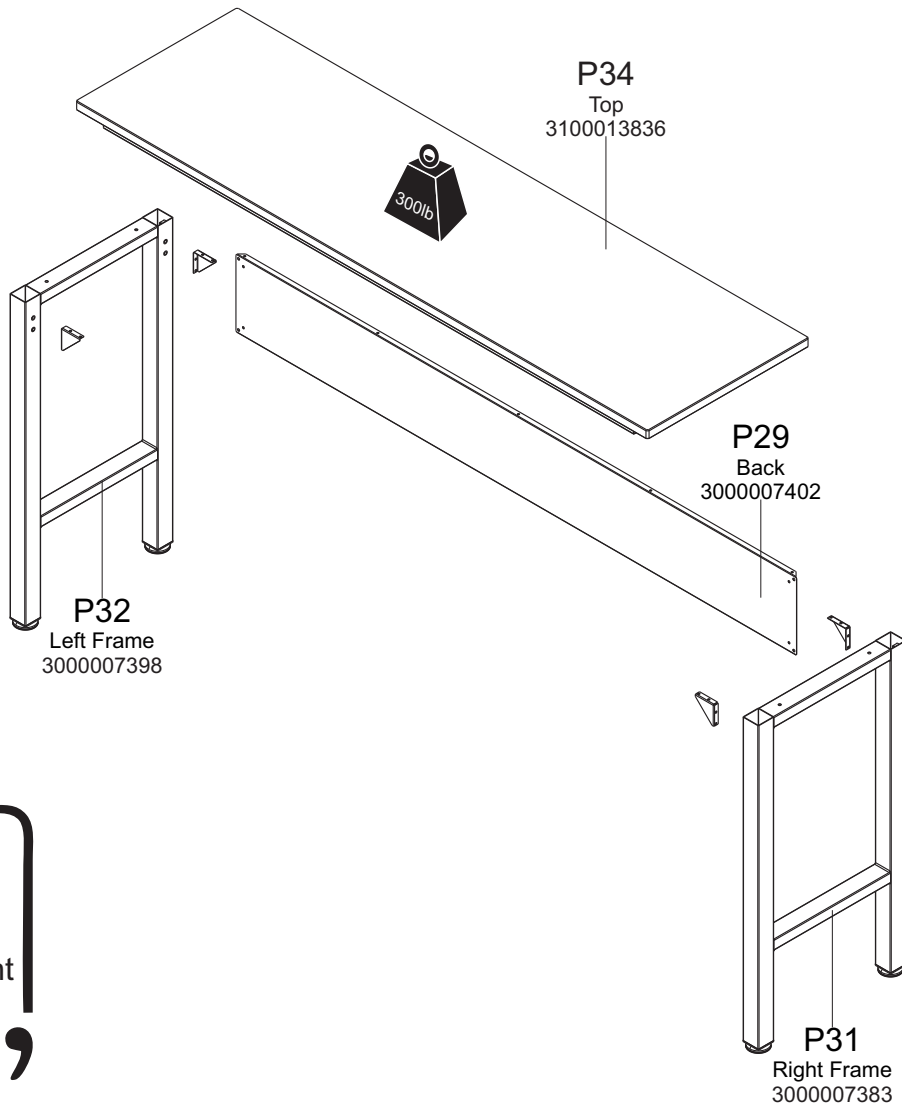

WARNING

“  
  
 Maximum weight supported by work surface  
 ”

## Hardware list

**F2**

1000009499

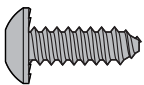

Qty. 3

**F3**

1000008391

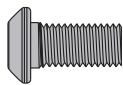

Qty. 20

**F8**

1000008387



Qty. 20

**F4**

1000008299

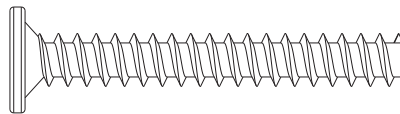

Qty. 4

**F9**

1000008368

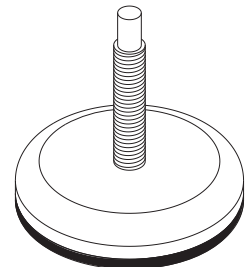

Qty. 4

**F13**

1000009033

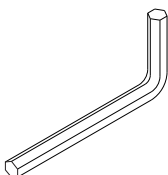

Qty. 1

**F16**

3000007407

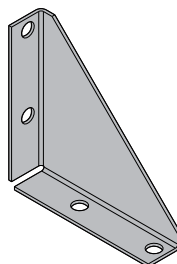

Qty. 4

**F17**

1000008285



Qty. 1

**STEP 1**

1. Fit the shoes to frame **P32** and **P31** base and turn to screw. To level the height of the table, turn the shoe clockwise or counterclockwise until is aligned

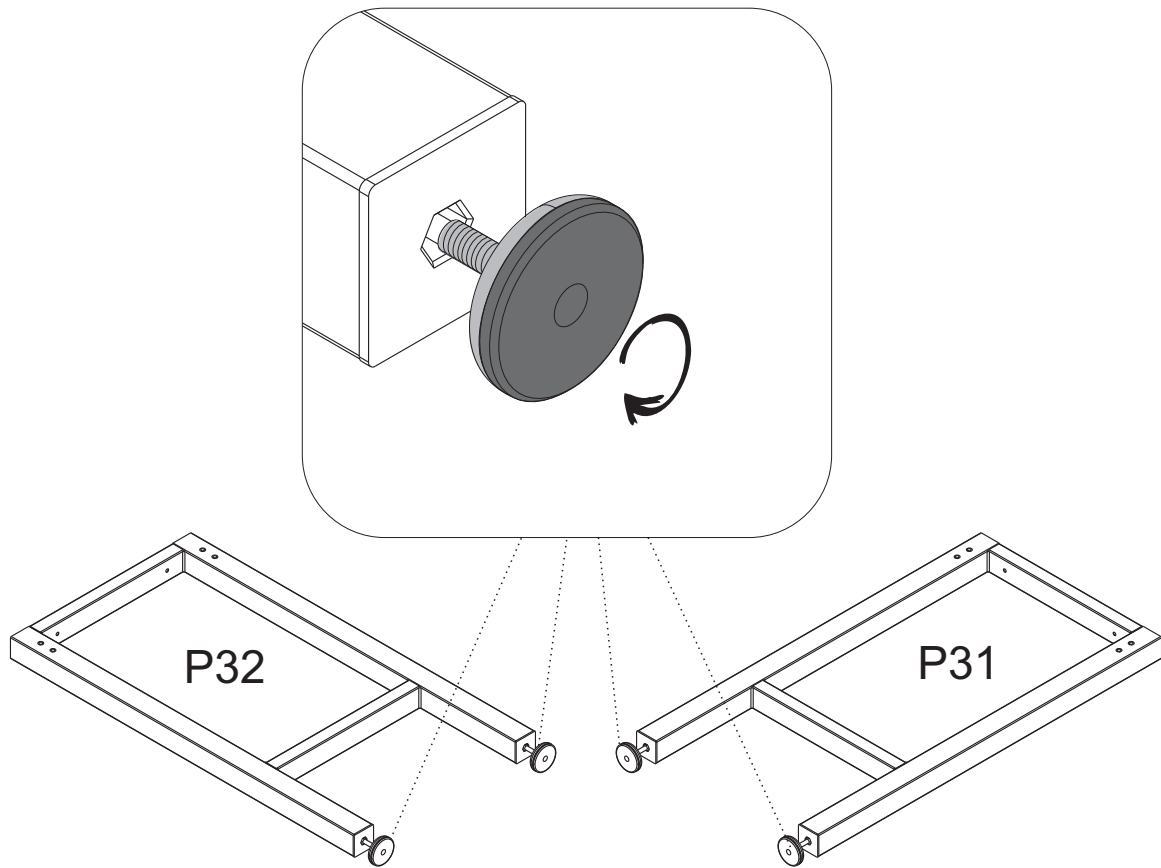
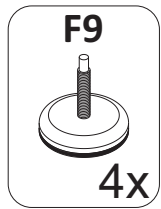
**STEP 2**

1. Align corner brackets **F16** to the upper sides of frames **P31** and **P32** and fix them with **F3** and **F8**

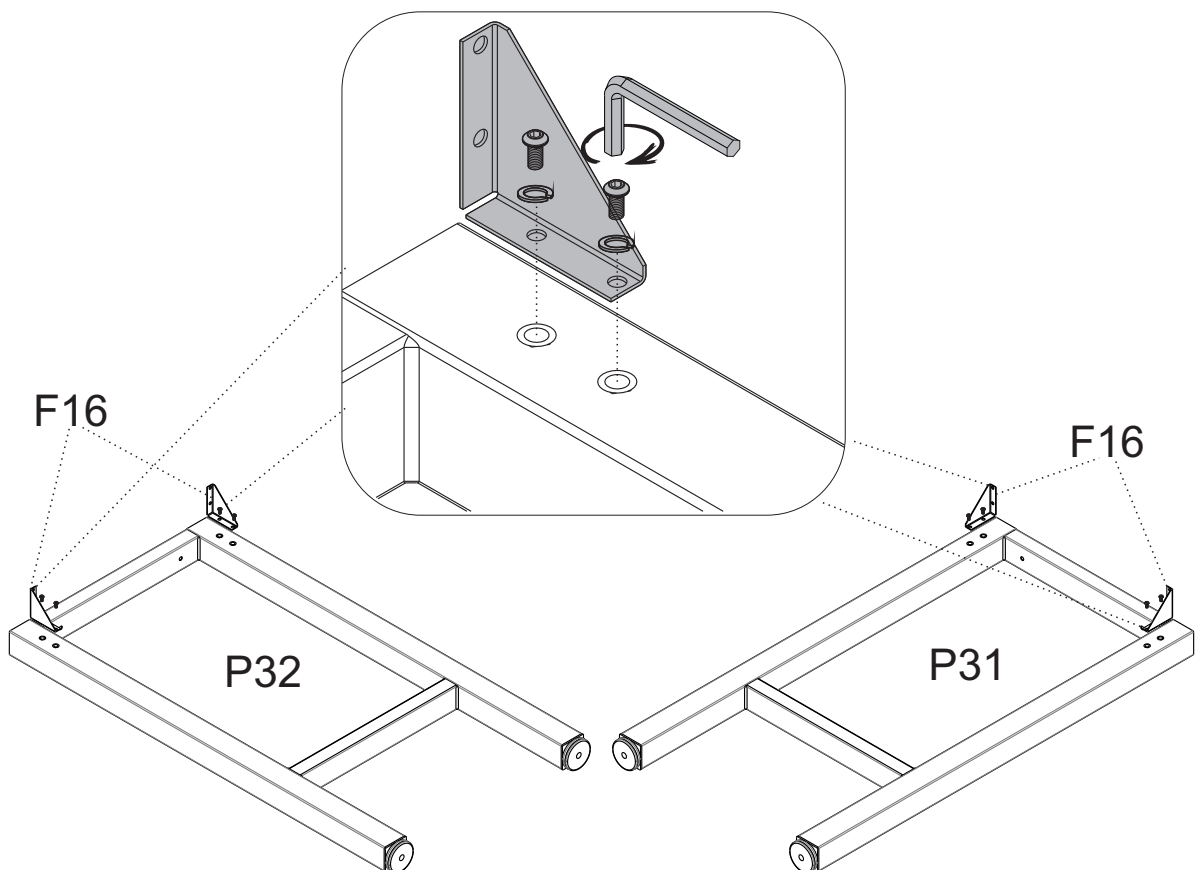
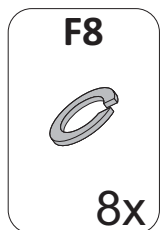
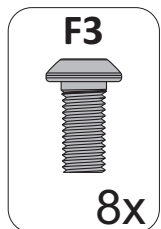
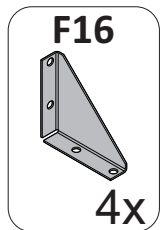

### STEP 3

1. Align frames **P31** and **P32** to **P34**

2. Fix corner brackets **F16** to the metallic part of **P34**, with **F3** and **F8**

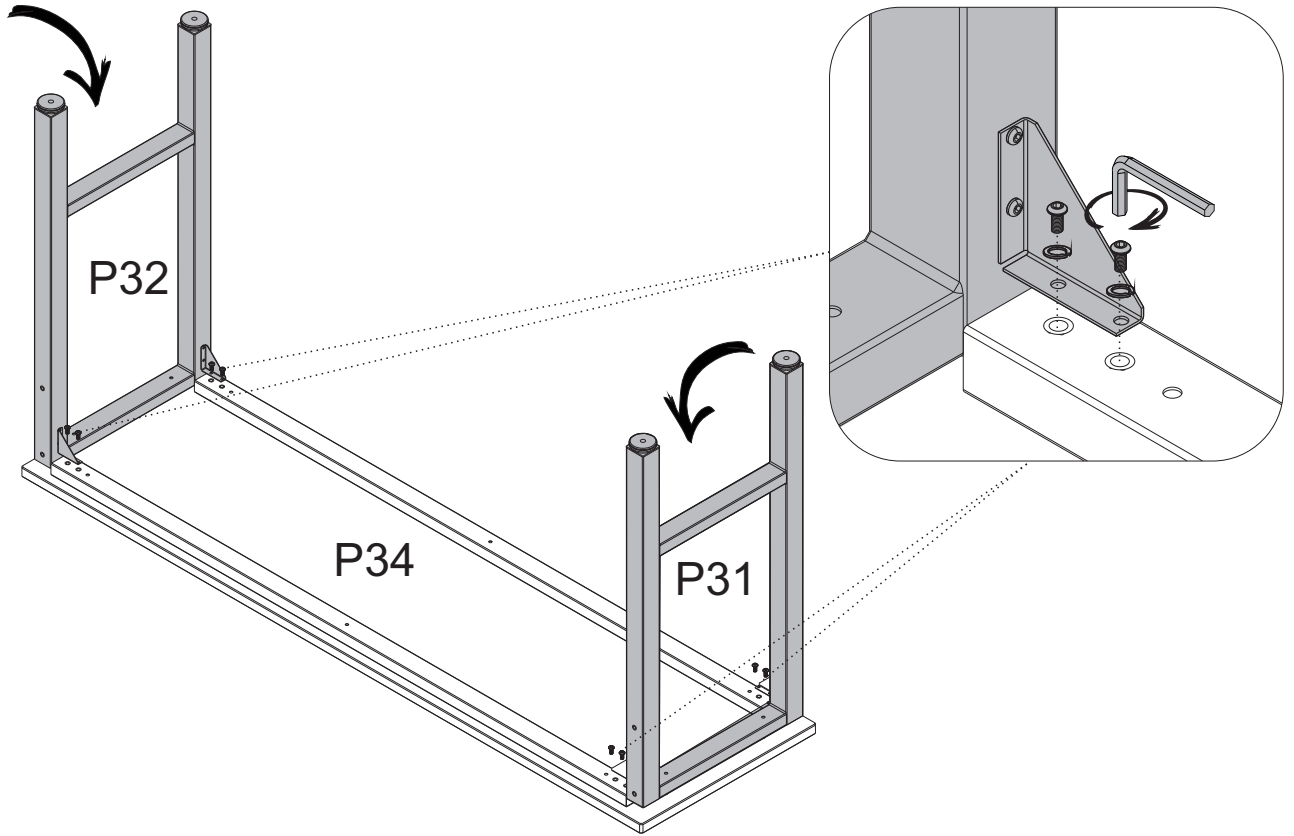
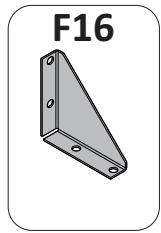
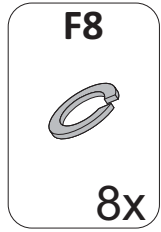
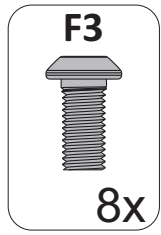

### STEP 4

1. Then, fix frames **P31** and **P32** to the wooden part of part **P34**, with **F4**

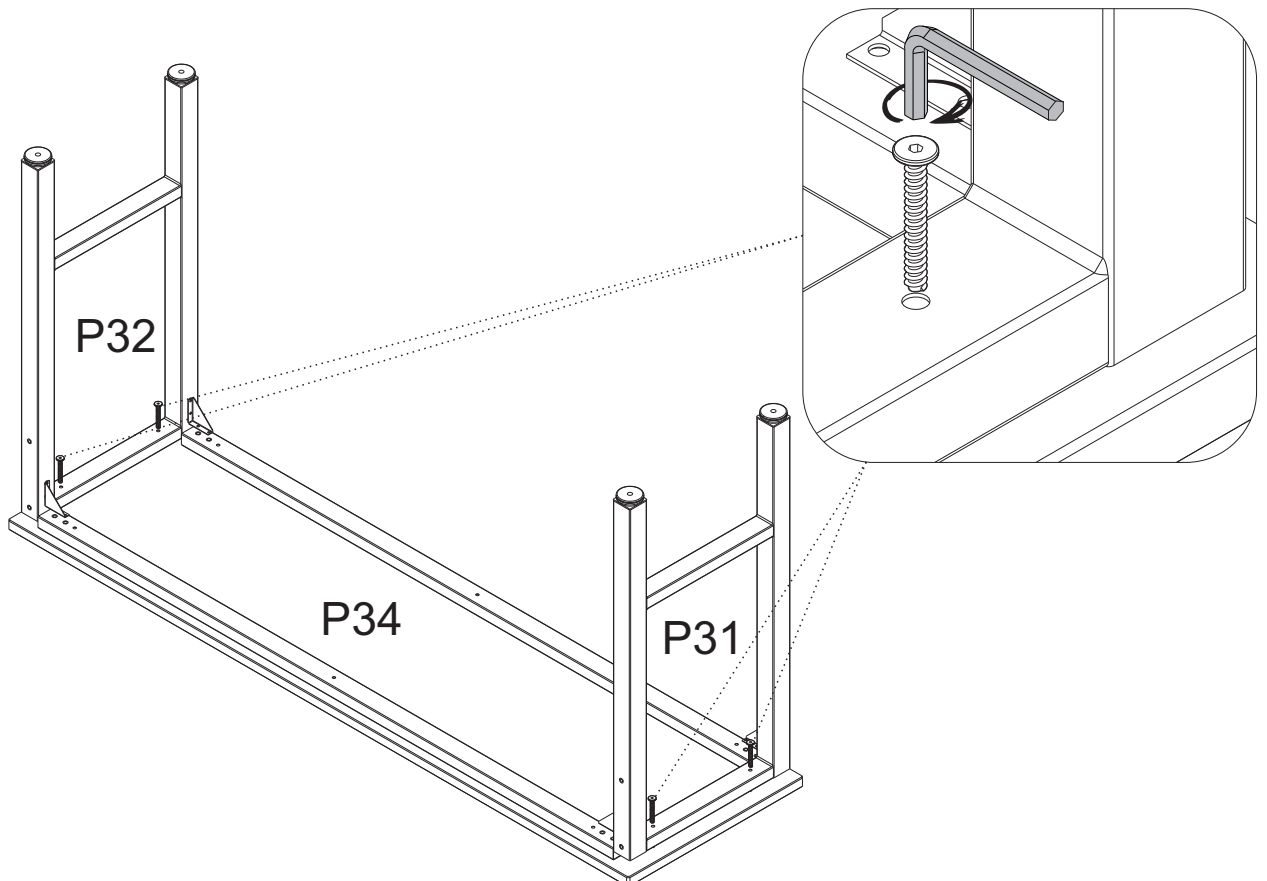
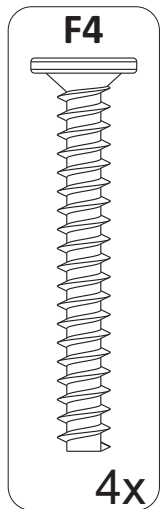

**STEP 5**

1. Align the part **P29** to frames **P31** and **P32**
2. Fix part **P29** to frames **P31** and **P32** with **F3** and **F8**

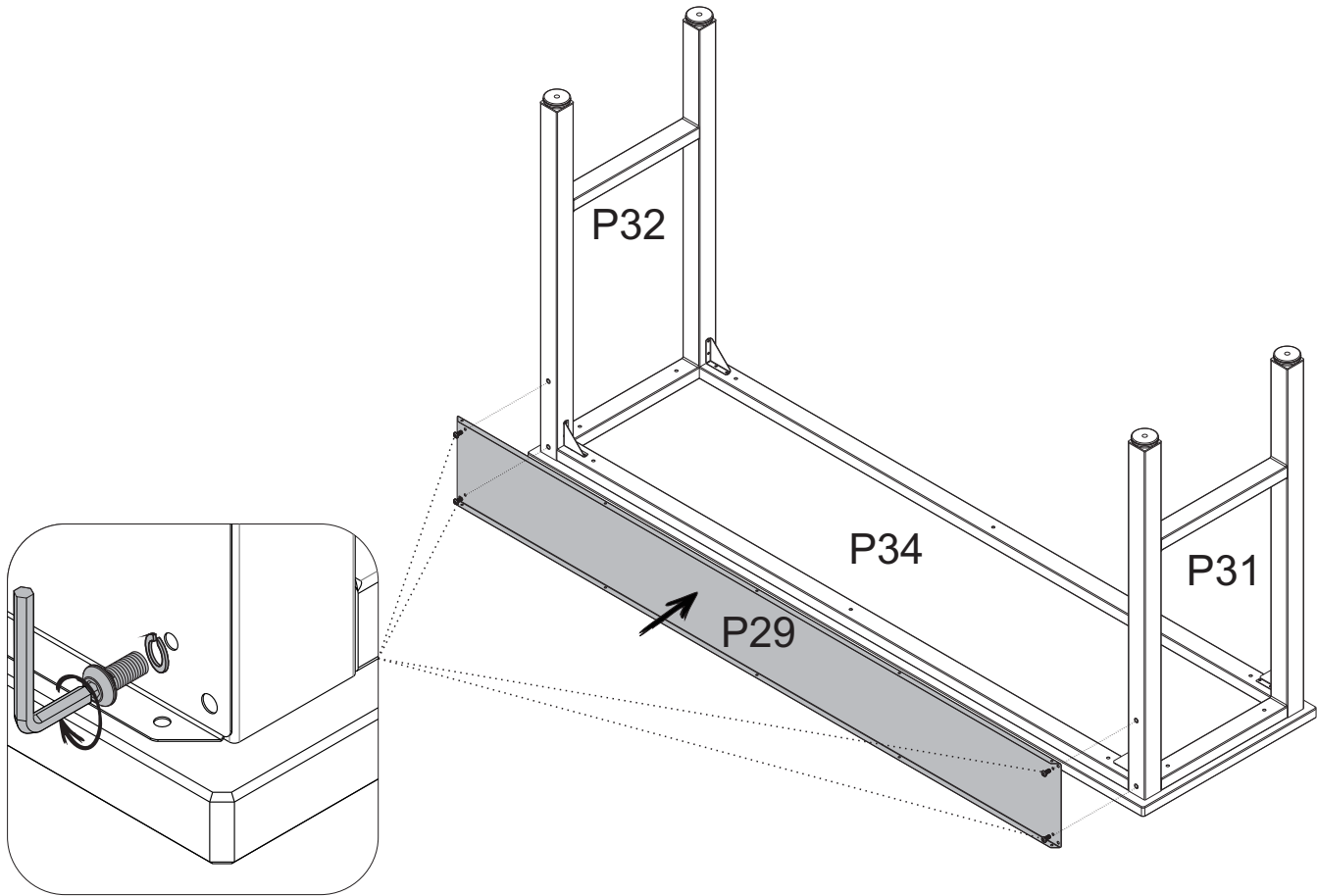
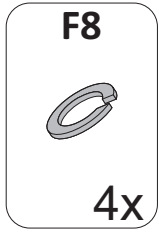
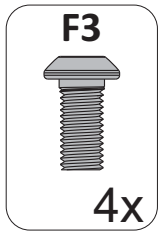

**STEP 6**

1. Fix part **P29** to part **P34** wooden side, with **F2**

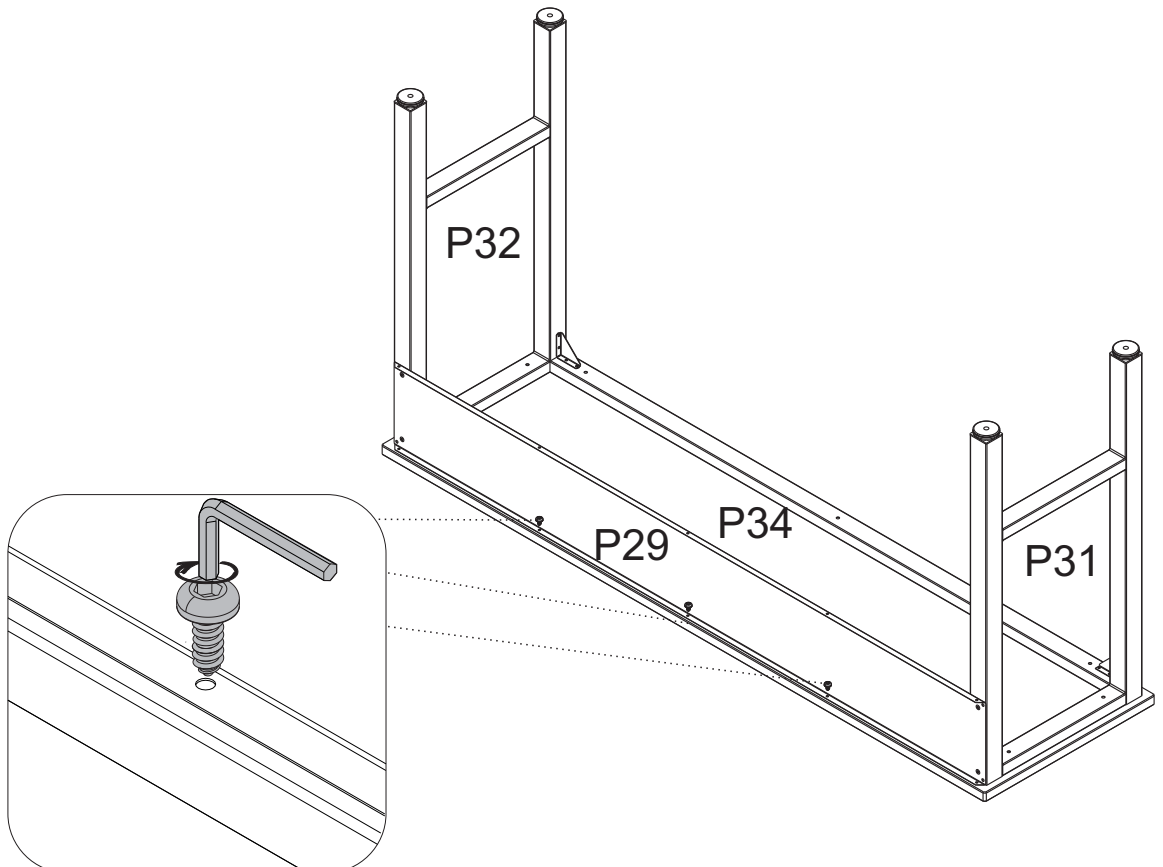
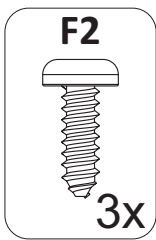

**STEP 7**

1 -Insert product log

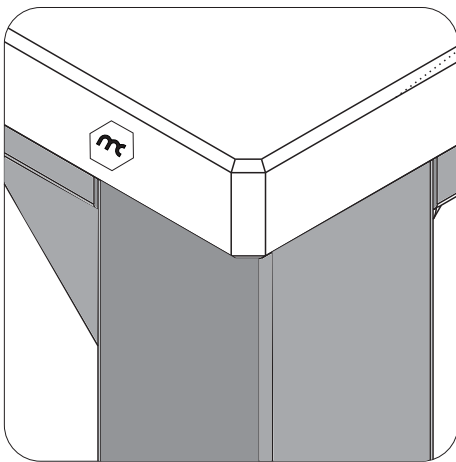
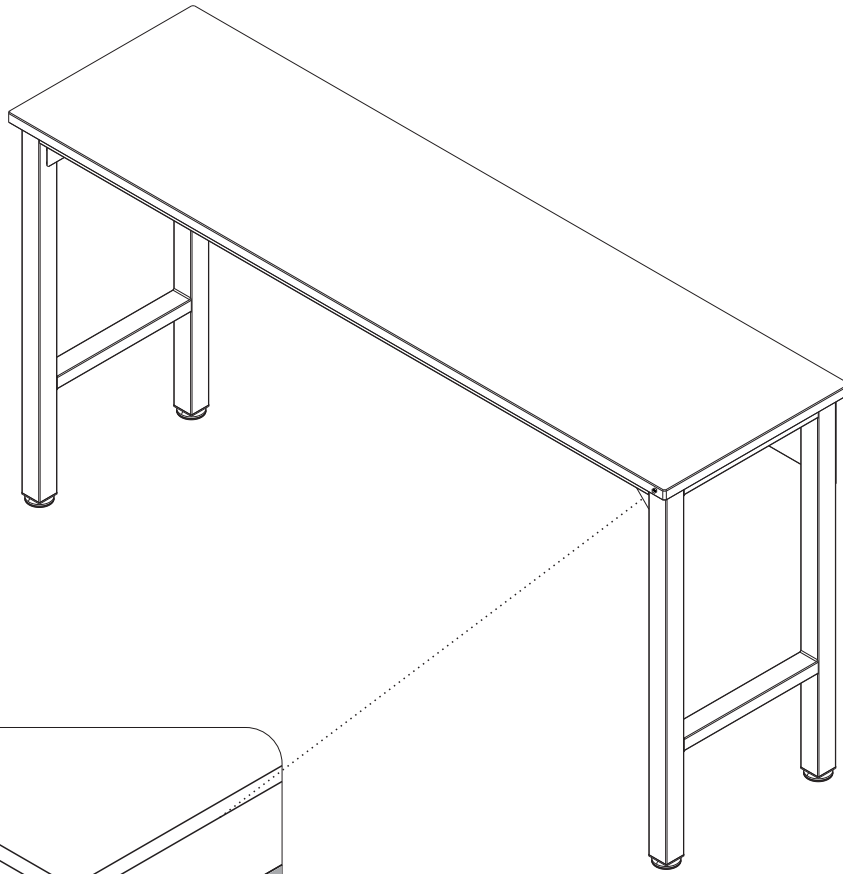
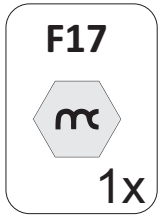

# ASSEMBLY HANDBOOK - FORTRESS 31.5" MOBILE GARAGE CABINET WITH SHELVESS

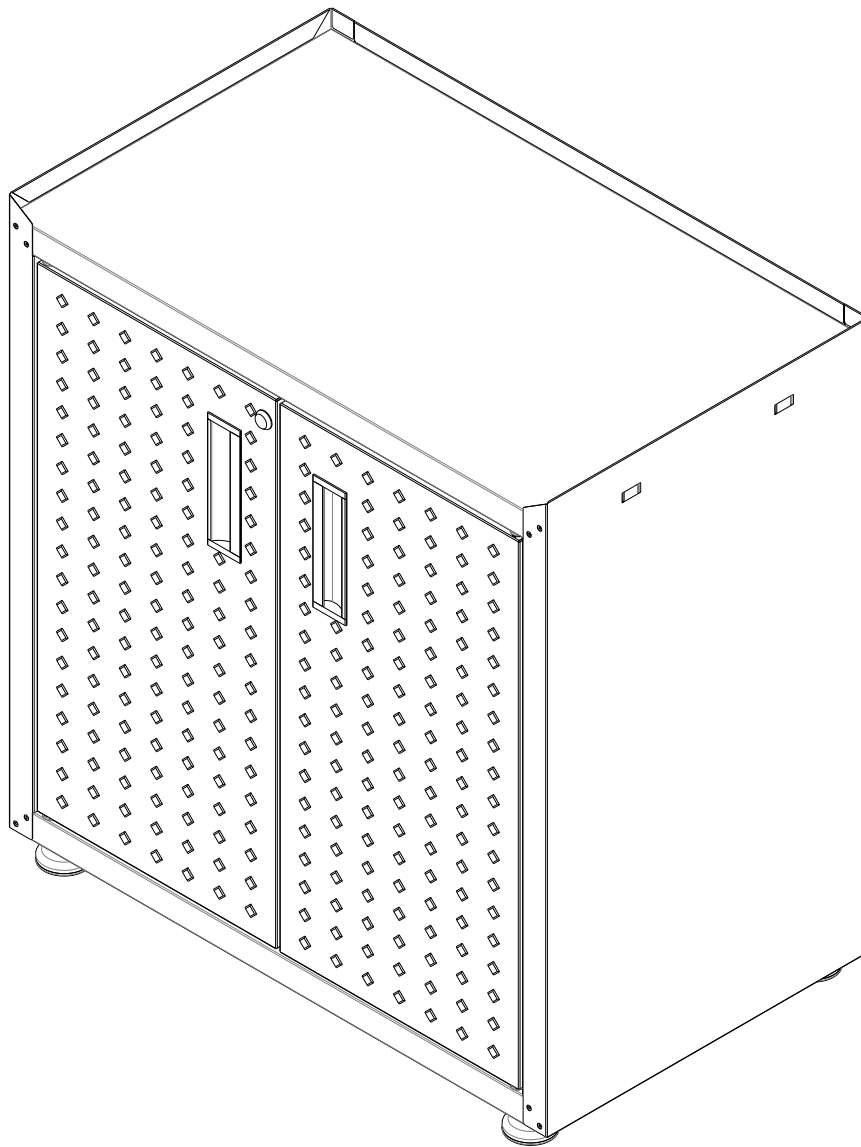

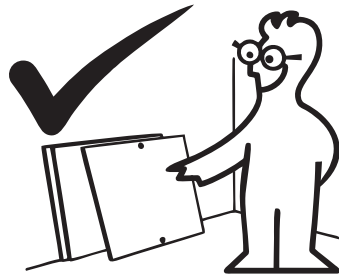
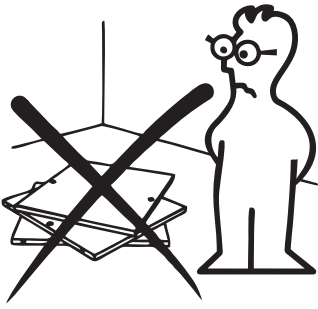

In order to ease the assembly, you should separate and identify the parts first

### Necessary hardware for the assembly

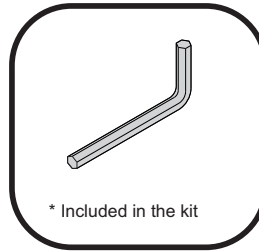
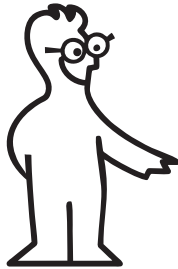

\* Included in the kit

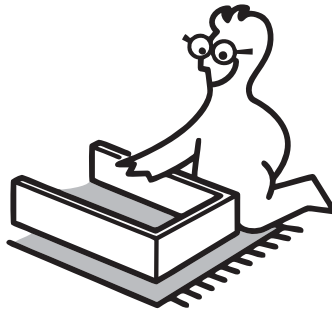
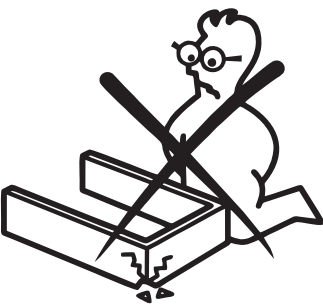

Do not place the parts directly onto the floor. Use a cardboard sheet or a mat to place the parts, during the separation and assembly.

### IMPORTANT

In order to avoid severe or even fatal injuries, follow the instructions carefully.

# ASSEMBLY HANDBOOK - FORTRESS 31.5" MOBILE GARAGE CABINET WITH SHELVES

P10

Upper Back  
3000007312



WARNING



P3  
Left Side  
3000007316

P5  
Top  
3000007270

P19  
Shelf  
3000007311

P9  
Lower Back  
3000007366

P22  
Left Door  
3000007302

P23  
Right Door  
3000007304

P7  
Bottom  
3000007271

P2  
Right Side  
3000007308

## Hardware list

**F1**

1000009500

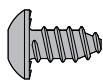

Qty. 16

**F7**

1000008301

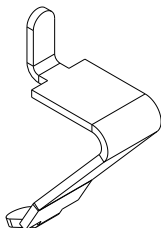

Qty. 4

**F15**

1000008280

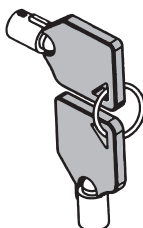

Qty. 1

**F13**

1000009033

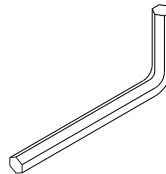

Qty. 1

**F17**

1000008285



**F9**

1000008368

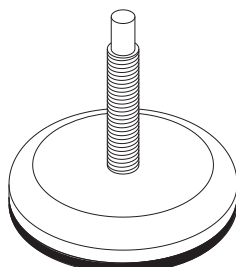

Qty. 4

\* Only in cabinets without caster

**F3**

1000008391

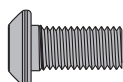

Qty. 16

\* Only in cabinets with caster

**F10**

1000008352

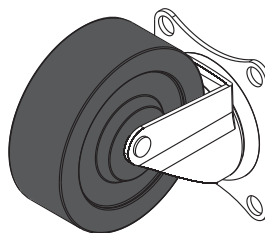

Qty. 2

**F11**

1000008354

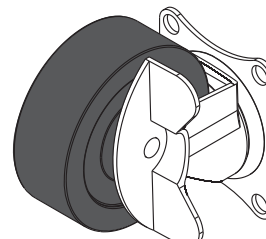

Qty. 2

- STEP 1**
- 1 - Fit part **P7** inside part **P3**
  - 2 - Fit both parts in the frontal side, with **F1**

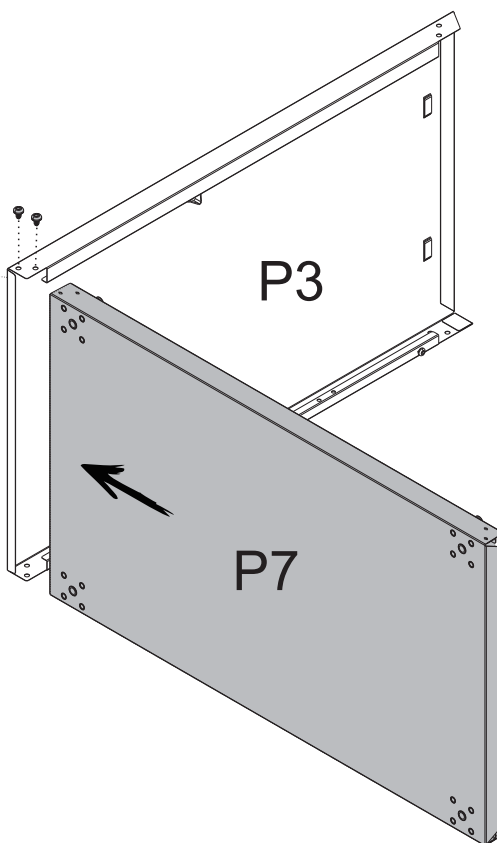
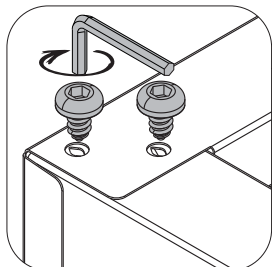
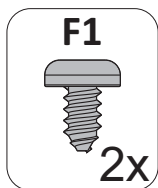

- 
- STEP 2**
- 1 - Fit part **P2** inside part **P7**
  - 2 - Fit both parts in the frontal side, with **F1**

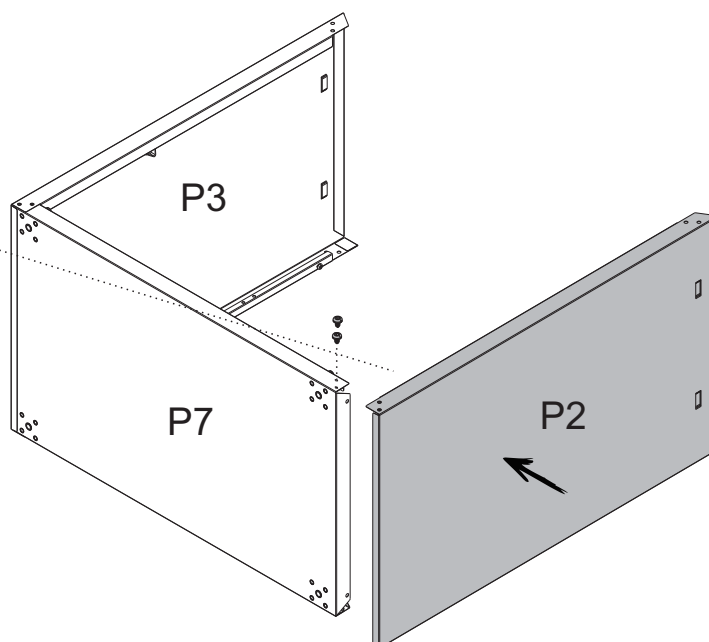
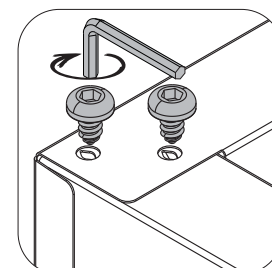
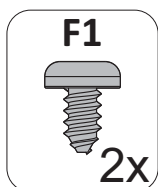

### STEP 3

- 1 - Fit part **P5** between part **P2** and **P3**
- 2 - Check that all 4 tabs have been fitted
- 3 - Fit part **P5** to parts **P2** and **P3**, at the frontal side, with **F1**

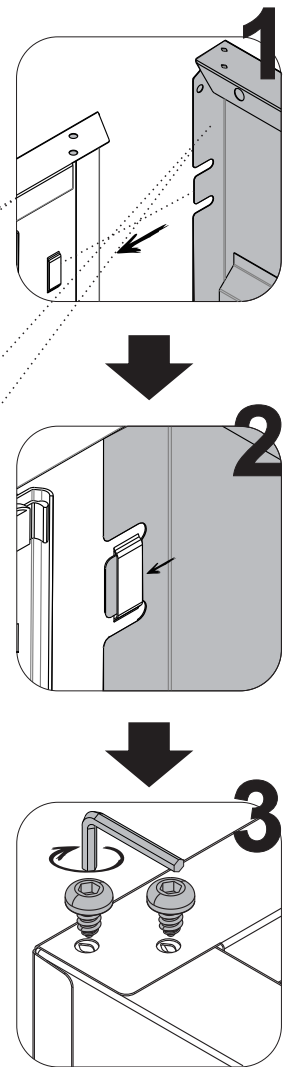
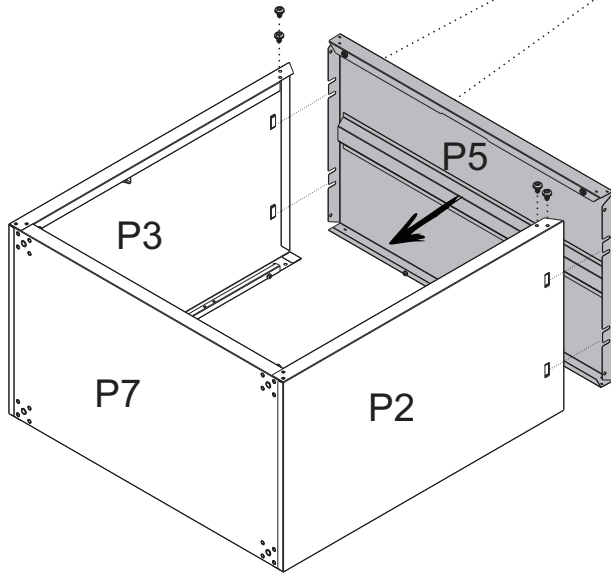
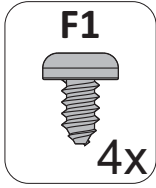

### STEP 4

- 1 - Turn the cabinet with the back side upwards

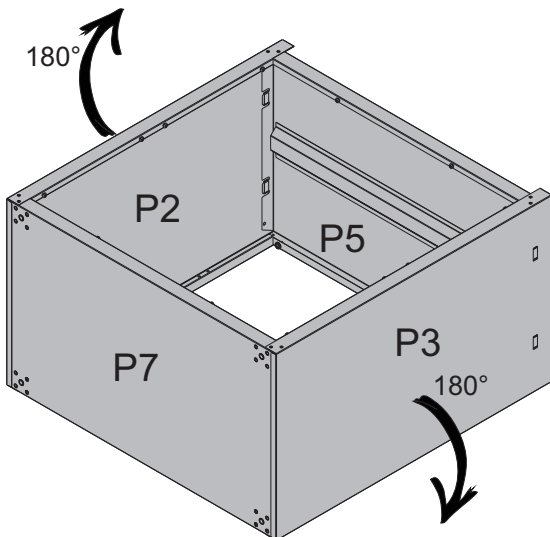
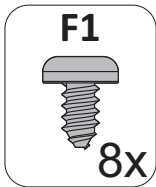

- 2 - Fit parts **P2** and **P3** to parts **P5** and **P7** with **F1**

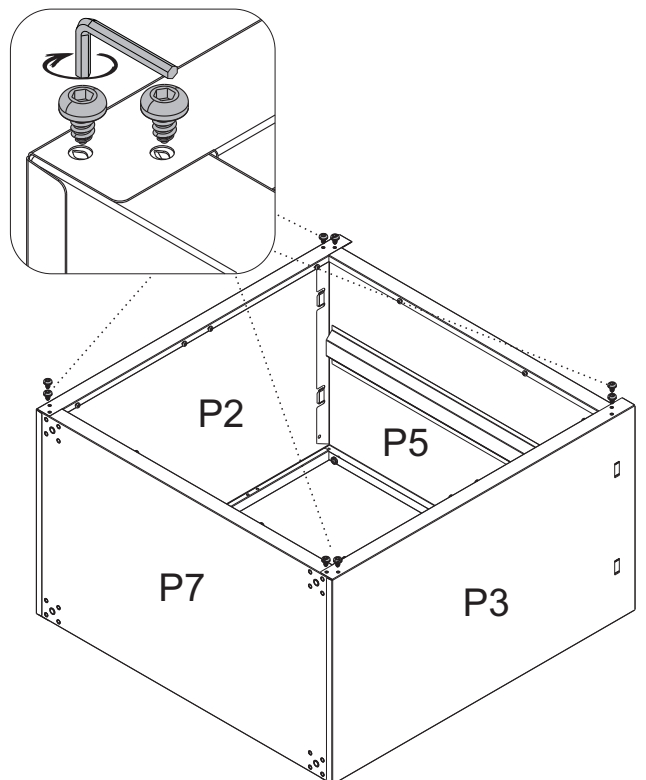

## STEP 5

- 1 - Fit part **P10** into parts **P2**, **P3** and **P5**  
Check that all fits are supported over the bolts
- 2 - After fitting the parts, screw the bolts until locked



“  
Position part P10  
on the P5 side for  
mounting the  
”

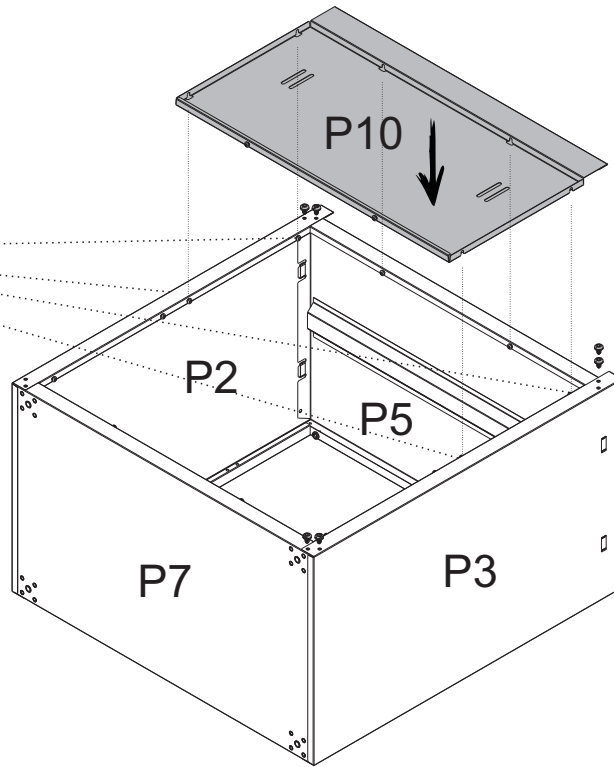
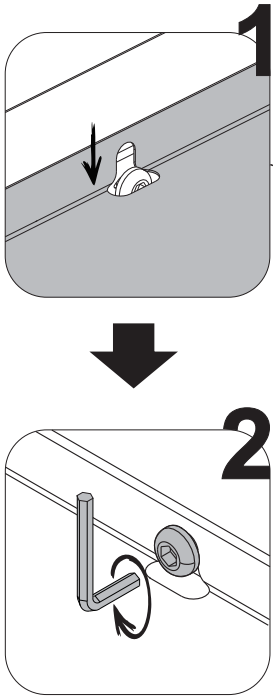

- ## STEP 6
- 1 - Fit part **P9** into parts **P2**, **P3** and **P7**  
Check that all fits are supported over the bolts
  - 2 - After fitting the parts, screw the bolts until locked

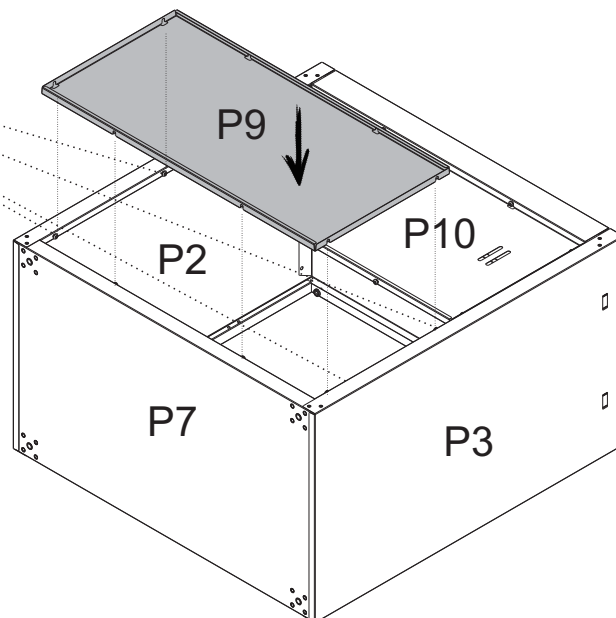
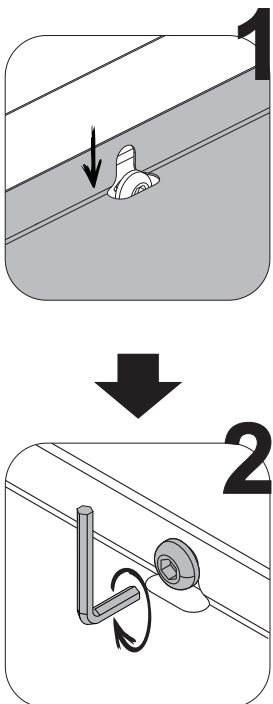

## STEP 7

1 - To assembly the cabinet with shoe fit the accessory **F9** in part **P7** as illustrated here below and turn to screw. To level the height or the cabinet, turn the shoe either clockwise or counterclockwise to align it.

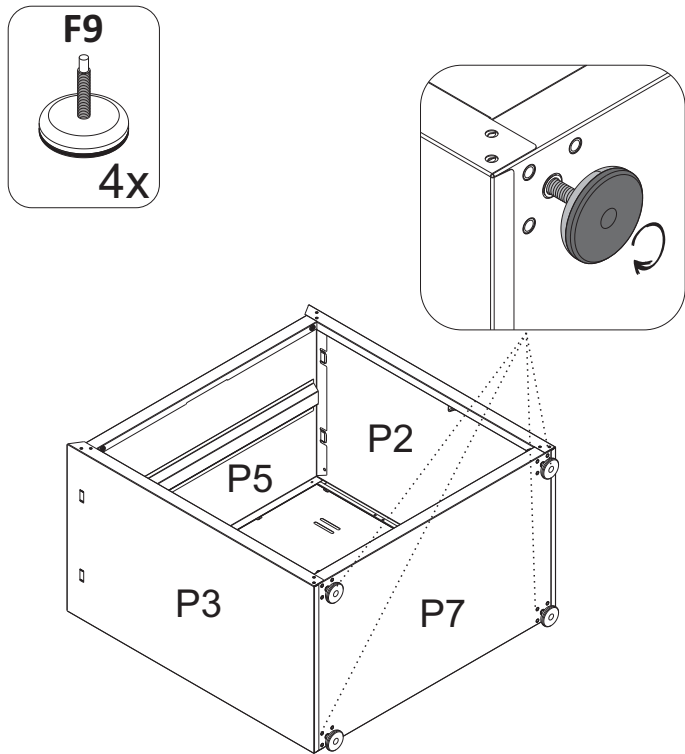

\* Only in cabinets without caster

2 - To assembly the cabinet with caster, align the **F10** and **F11** to the holes in part **P7** and fix them with **F3**

3 - **WARNING:** Casters with lock (**F11**) must be fitted in the frontal side of the cabinet

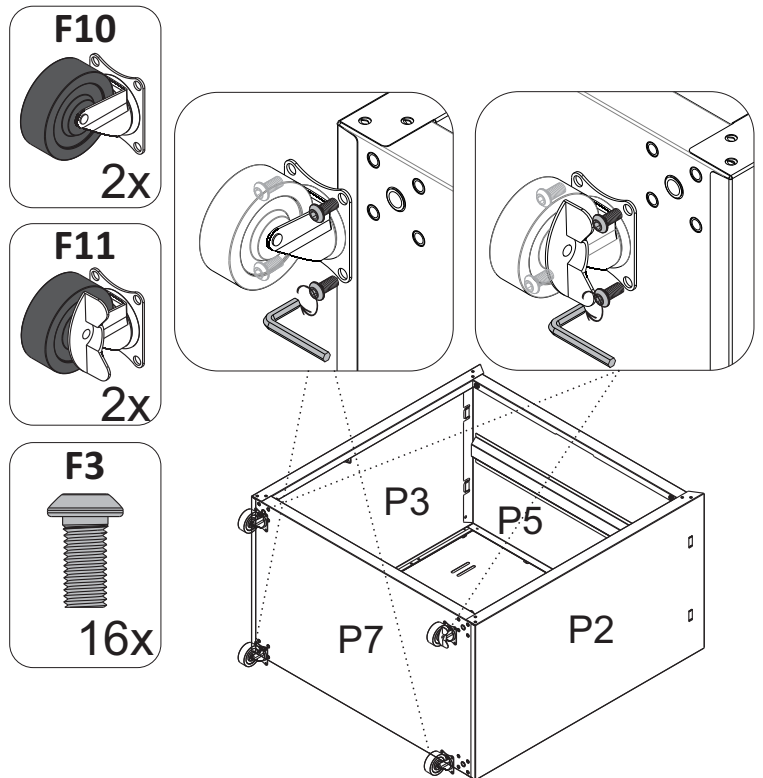

\* Only in cabinets with caster

## STEP 8

1- Turn the cupboard so that it will stand in the position of use  
2- Fix **F7** to parts **P2** and **P3**, as shown here below

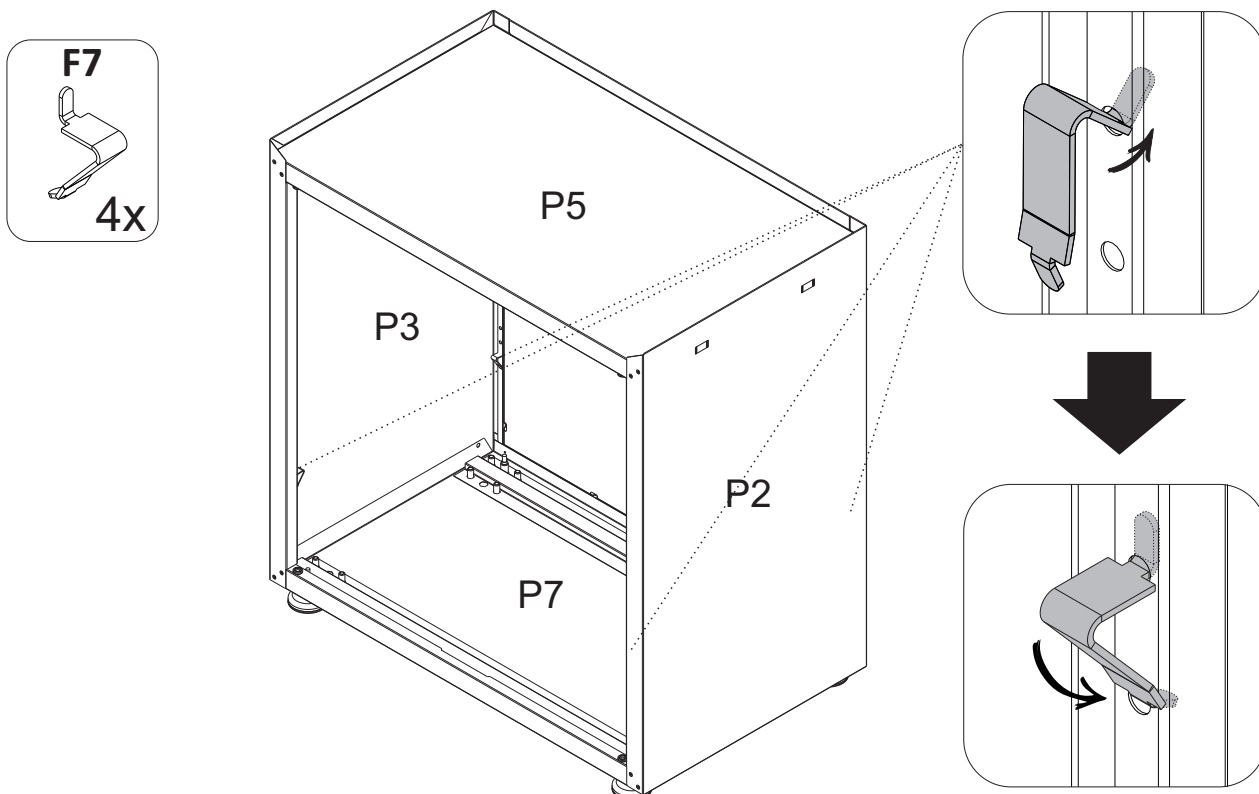

## STEP 9

- 1 - Fit the lower part **P19** in diagonal position to insert it inside the cupboard
- 2 - Lean part **P19** in part **P2**, **P3** and place it over the **F7** detailed in the figure here below
- 3 - Lower the other side of part **P19**, leaning it over the left **F7**

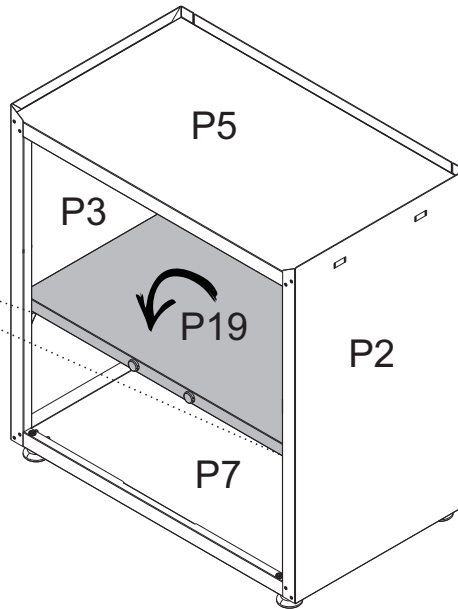
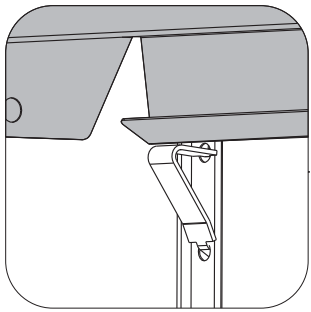
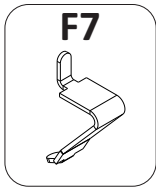

## STEP 10

- 1 - To assembly the doors, fit door **P23** lower hinge bolt inside the bushing fixed in part **P7**. Then, pull down the pin of door **P23** upper hinge; align the door and release the pin to fit the bushing fixed in part **P5**
- 2 - Repeat the step for part **P22**
- 3 - Insert product log

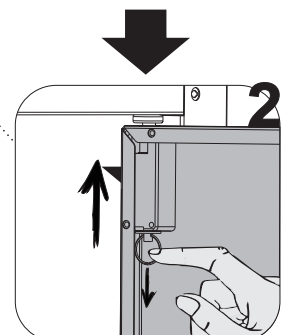
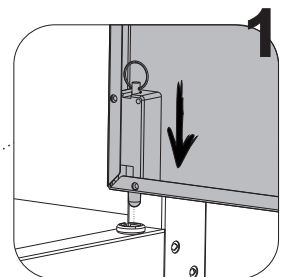
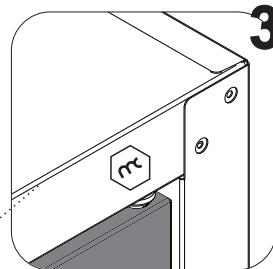
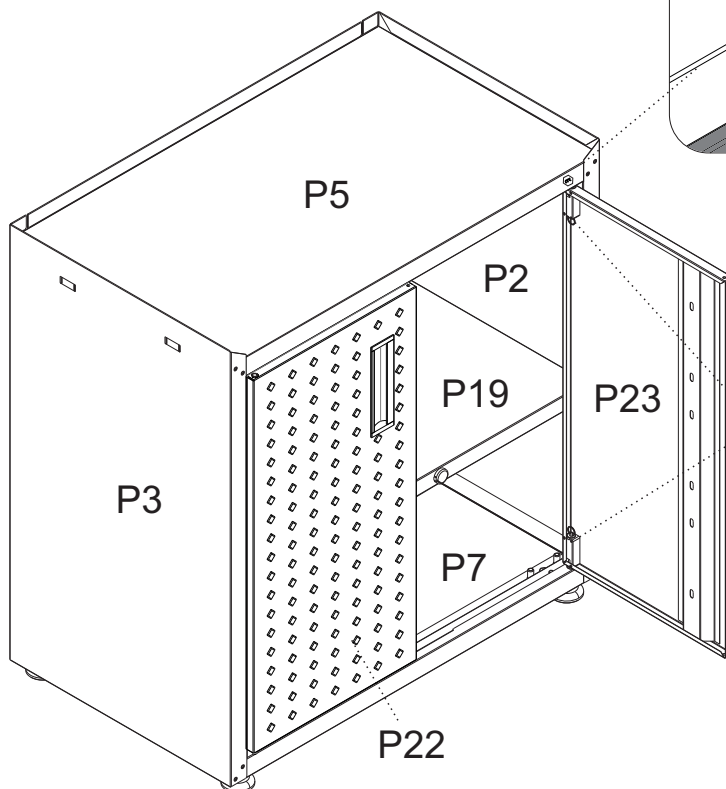
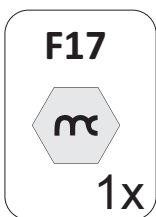

# ASSEMBLY HANDBOOK – FORTRESS 31.5" MOBILE GARAGE CHEST WITH DRAWERS

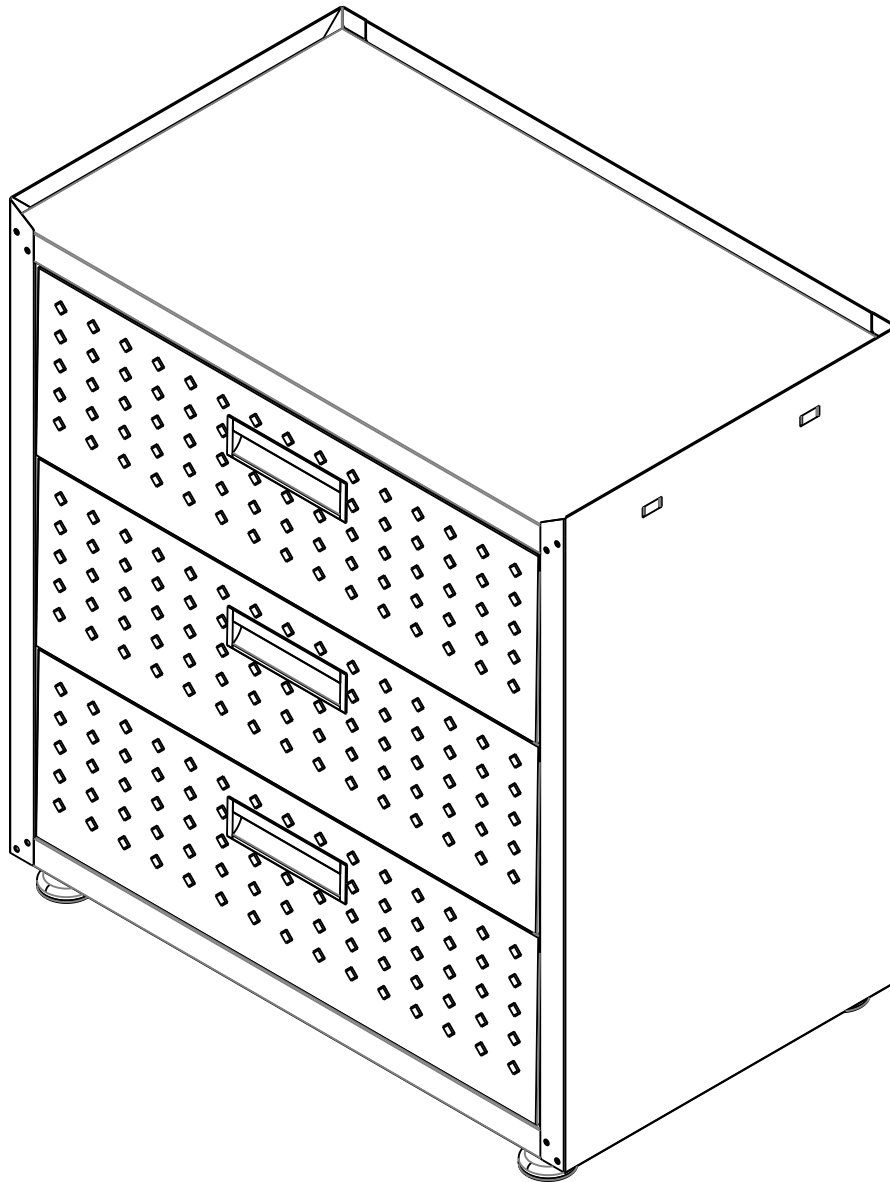

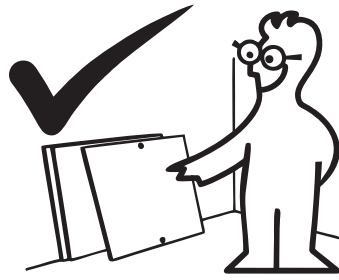
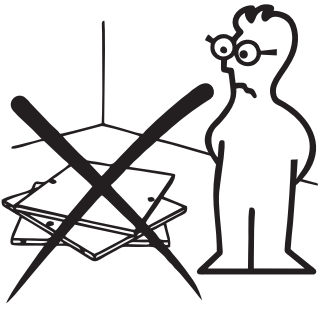

In order to ease the assembly, you should separate and identify the parts first

### Necessary hardware for the assembly

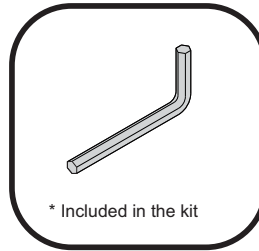
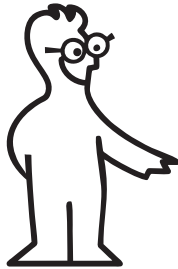

\* Included in the kit

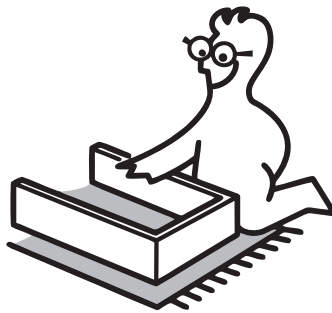
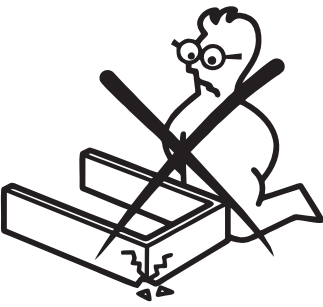

Do not place the parts directly onto the floor. Use a cardboard sheet or a mat to place the parts, during the separation and assembly.

### IMPORTANT

In order to avoid severe or even fatal injuries, follow the instructions carefully.

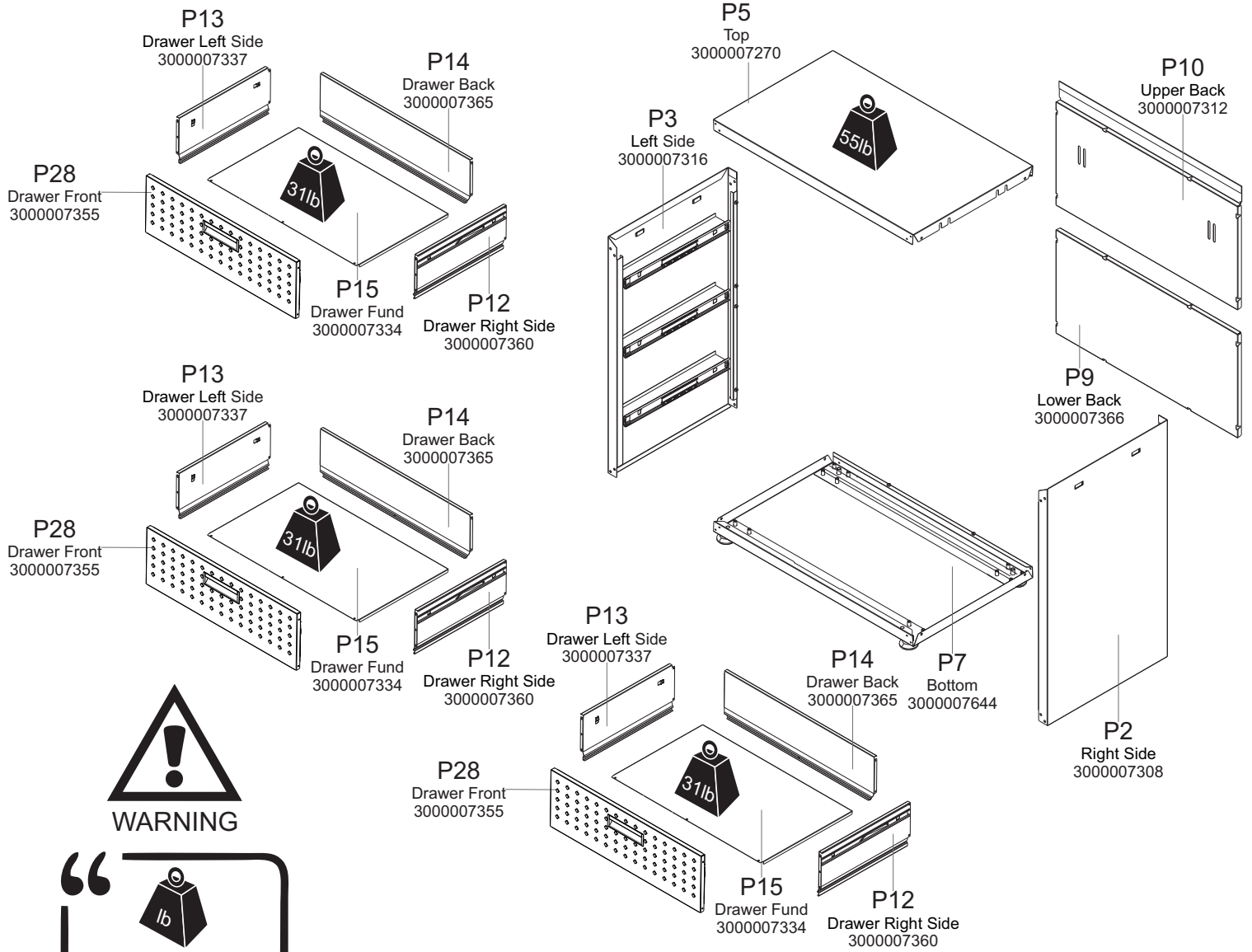

# ASSEMBLY HANDBOOK – FORTRESS 31.5" MOBILE GARAGE CHEST WITH DRAWERS



**WARNING**

“  Maximum weight supported by shelf and drawer ”

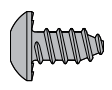
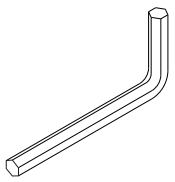
## Hardware list

- |   |   |  |
|---|---|--|
| <b>F1</b><br>1000009500   | <b>F13</b><br>1000009033  | <b>F17</b><br>1000008285   |
|  |  |  |
| Qty. 52   | Qty. 1  |  |

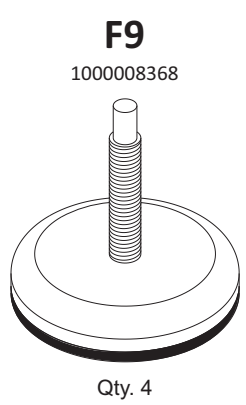

\* Only in cabinets without caster

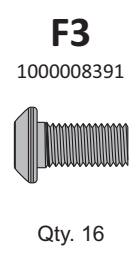

\* Only in cabinets with caster

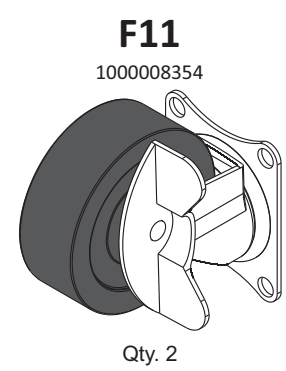
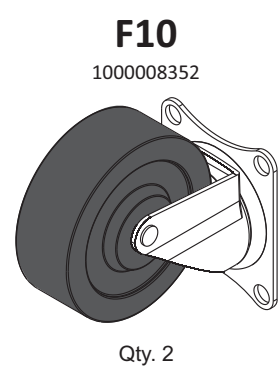

- STEP 1**
- 1 - Fit part **P7** inside part **P3**
  - 2 - Fit both parts in the frontal side, with **F1**

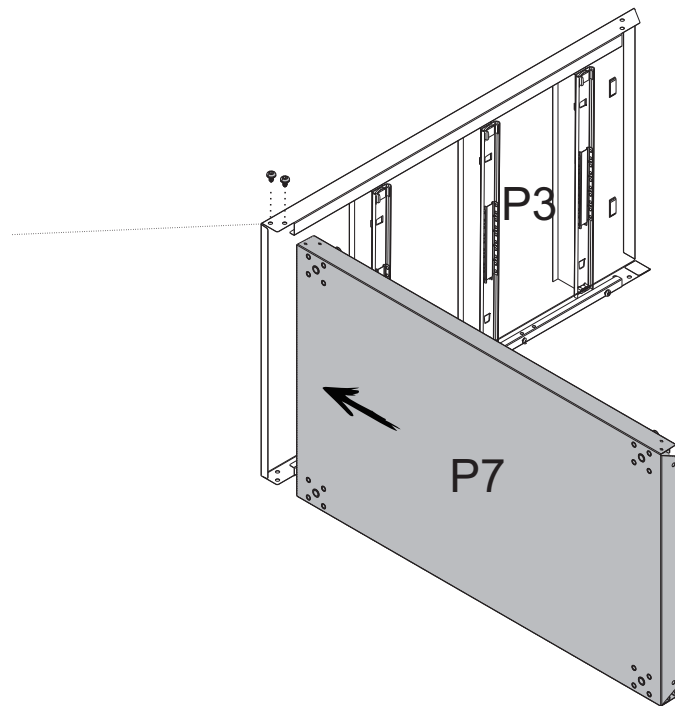
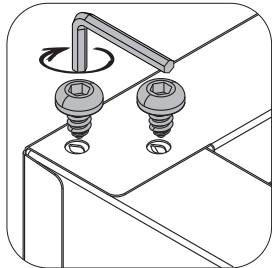
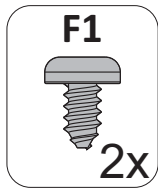

- 
- STEP 2**
- 1 - Fit part **P2** inside part **P7**
  - 2 - Fit both parts in the frontal side, with **F1**

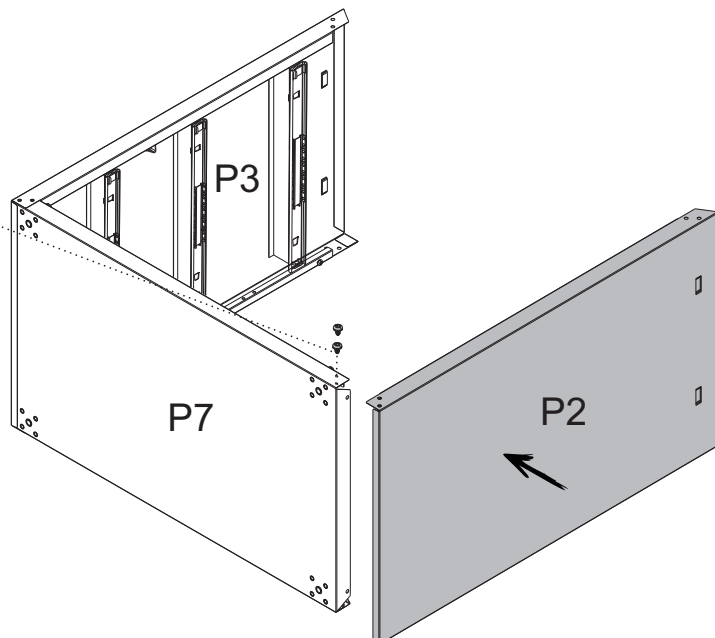
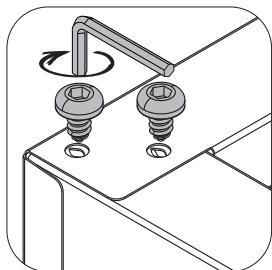
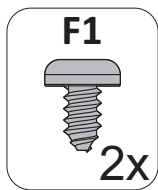

### STEP 3

- 1 - Fit part **P5** between part **P2** and **P3**
- 2 - Check that all 4 tabs have been fitted
- 3 - Fit part **P5** to parts **P2** and **P3**, at the frontal side, with **F1**

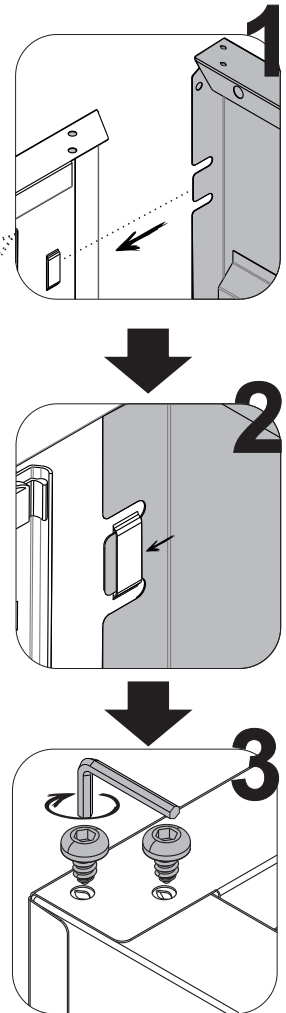
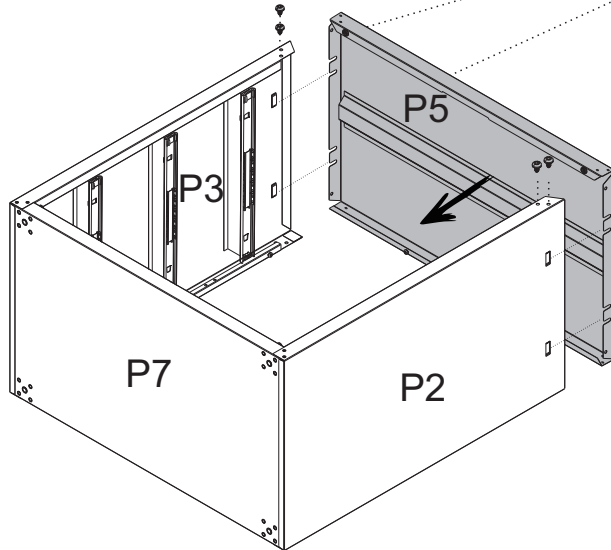
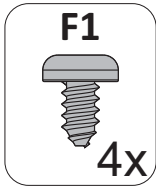

### STEP 4

- 1 - Turn the cabinet with the back side upwards

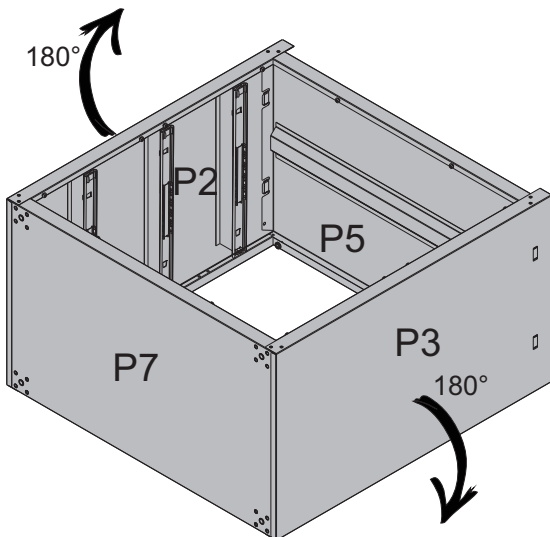
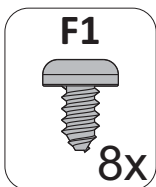

- 2 - Fit parts **P2** and **P3** to parts **P5** and **P7** with **F1**

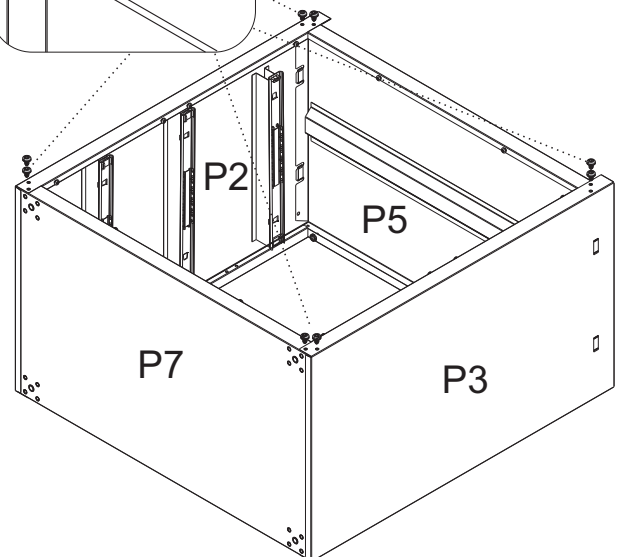
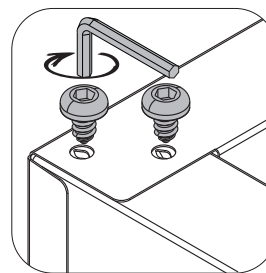

## STEP 5

- 1 - Fit part **P10** into parts **P2**, **P3** and **P5**.  
Check that all fits are supported over the bolts
- 3 - After fitting the parts, screw the bolts until locked

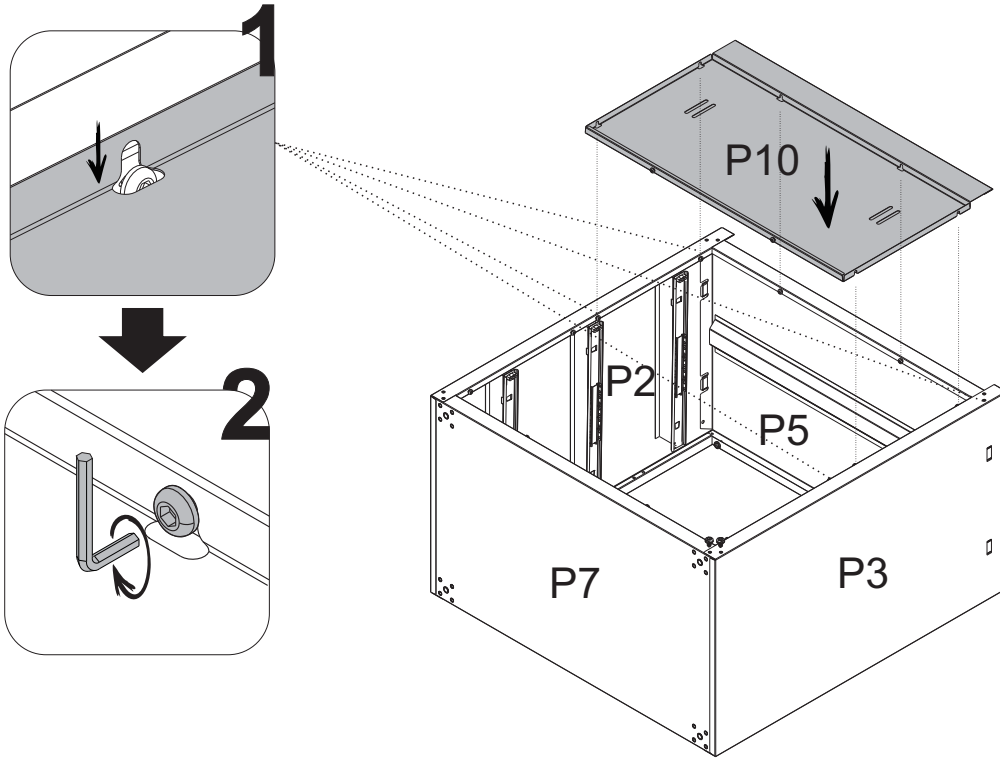

WARNING

“ Position part P10 on the P5 side for mounting the cabinet. ”

- ## STEP 6
- 1 - Fit part **P9** into parts **P2**, **P3** and **P7**.  
Check that all fits are supported over the bolts
  - 2 - After fitting the parts, screw the bolts until locked

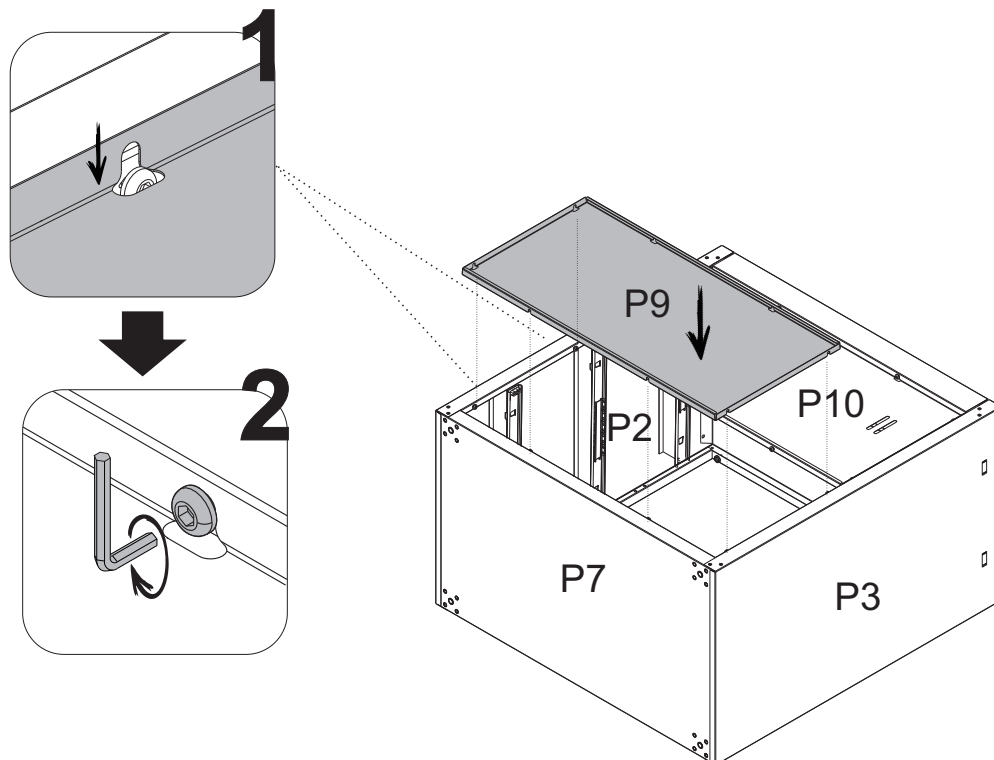

## STEP 7

1 - To assembly the cabinet with shoe fit the accessory **F9** in part **P7** as illustrated here below and turn to screw. To level the height or the cabinet, turn the shoe either clockwise or counterclockwise to align it.

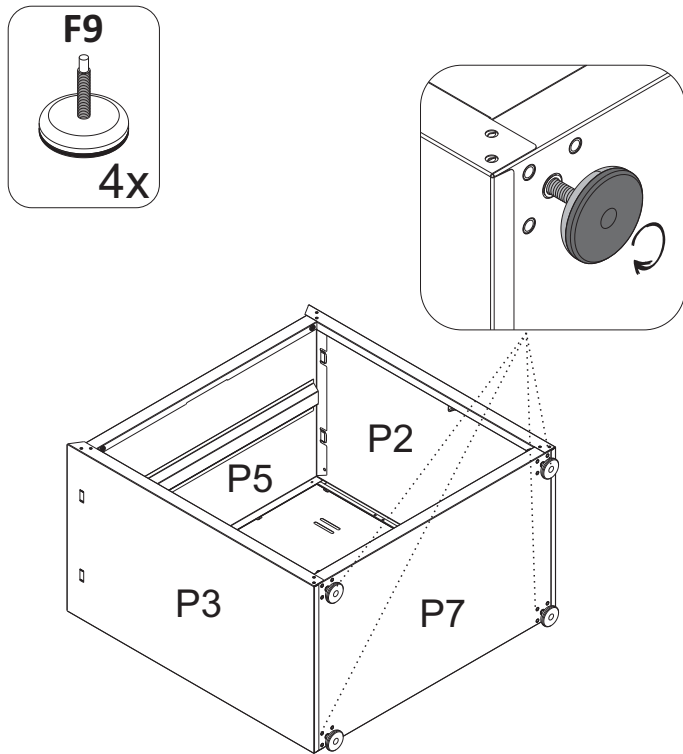

\* Only in cabinets without caster

2 - To assembly the cabinet with caster, align the **F10** and **F11** to the holes in part **P7** and fix them with **F3**

3 - **WARNING:** Casters with lock (**F11**) must be fitted in the frontal side of the cabinet

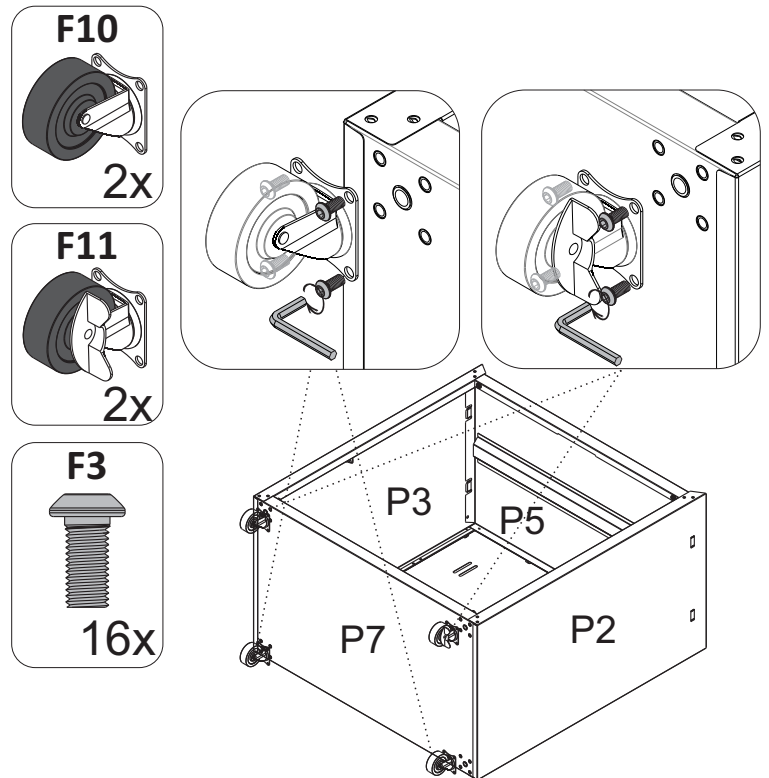

\* Only in cabinets with caster

## STEP 8

1 - Fit part **P15** to part **P28**

2 - Fit them with **F1**

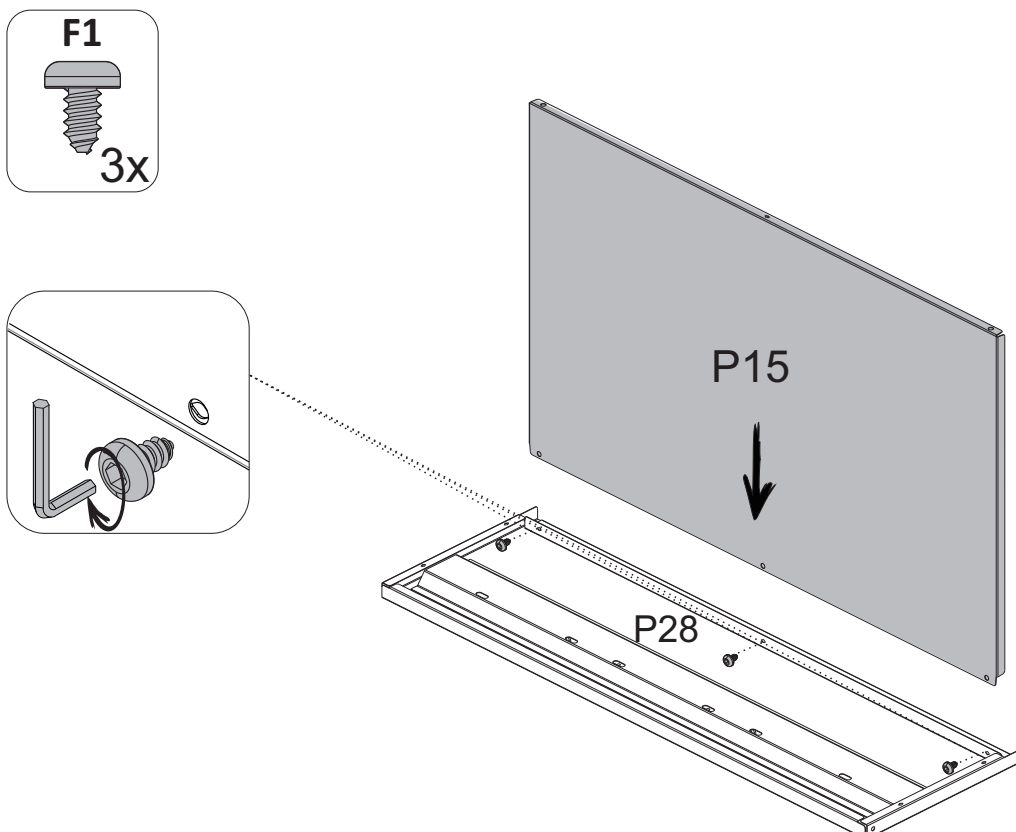

- STEP 13**
- 1 - Align parts **P12** and **P13** to part **P15**, until it leans against part **P28**
  - 2 - Fit them with **F1**

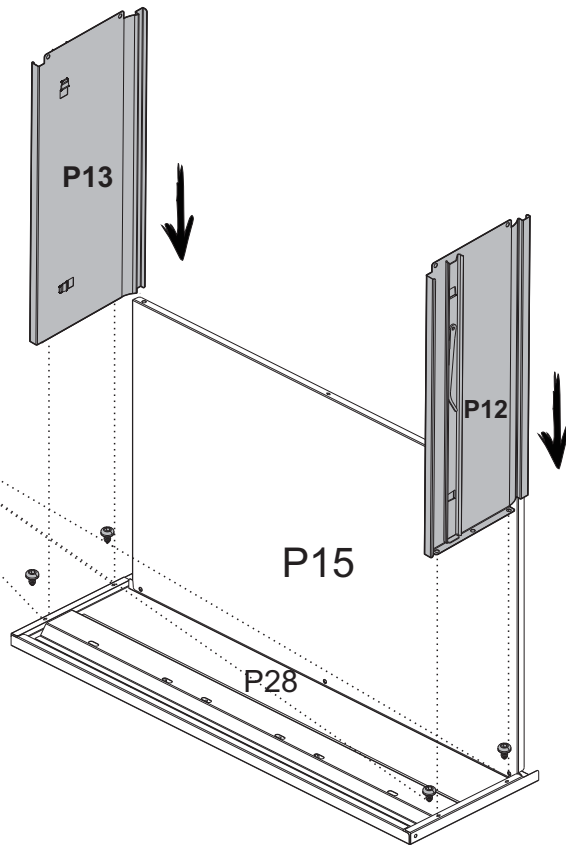
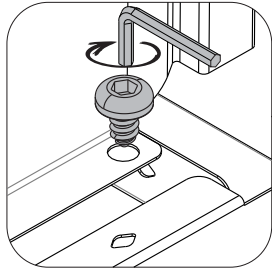
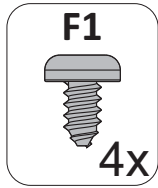

**STEP 14**

- 1 - Insert part **P14** over part **P15** and between parts **P12** and **P13**
- 2 - Then, fix part **P14** to parts **P12**, **P13** and **P15**, with **F1**

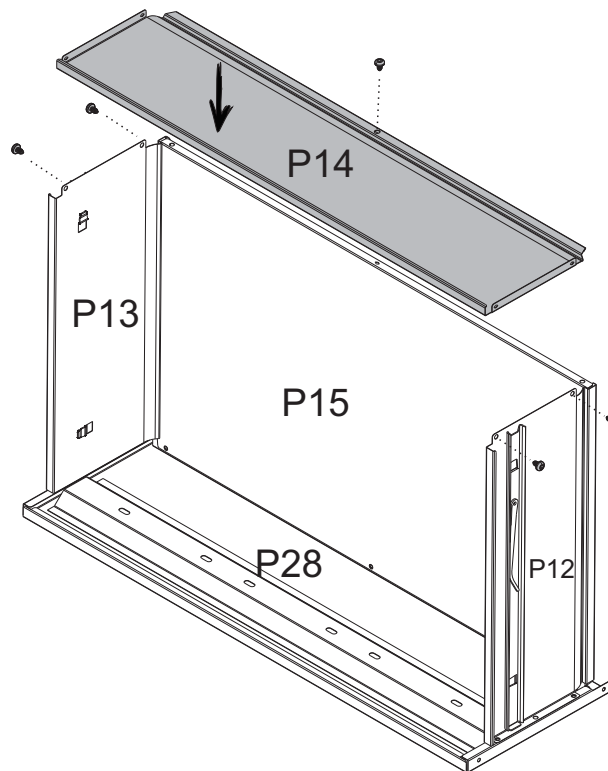
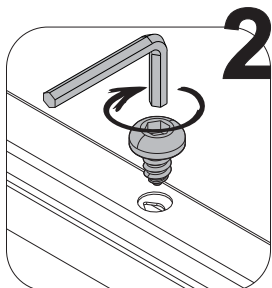
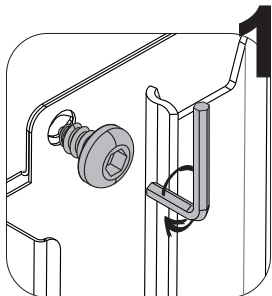
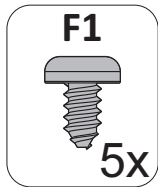

## STEP 14

- 1 - Fit the drawers – already assembled – between parts **P2** and **P3**, through the slidings
- 2 - Check that slidings of both sides are properly fitted. Move the drawer, opening and closing it, testing

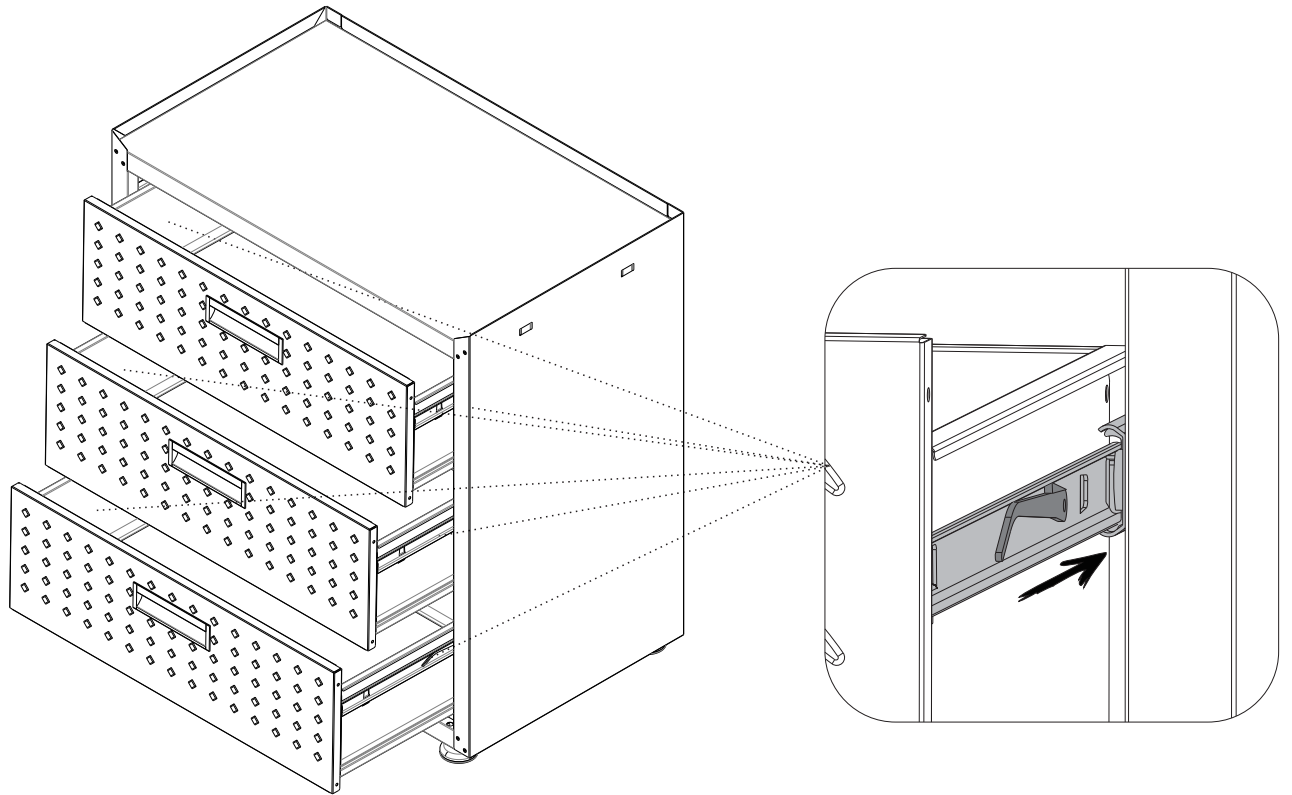

---

## STEP 15

- 1 -Insert product log

