

SKU N620P348471-N620P348472

Our product will be delivered to you in 2 packages. The delivery times of these 2 packages may differ, please be patient and thank you for your understanding.

Unser Produkt wird Ihnen in 2 Paketen geliefert. Die Lieferzeiten dieser 2 Pakete können abweichen, bitte haben Sie etwas Geduld und vielen Dank für Ihr Verständnis.

Notre produit vous sera livré en 2 colis. Les délais de livraison de ces 2 colis peuvent différer, soyez patient et merci de votre compréhension.

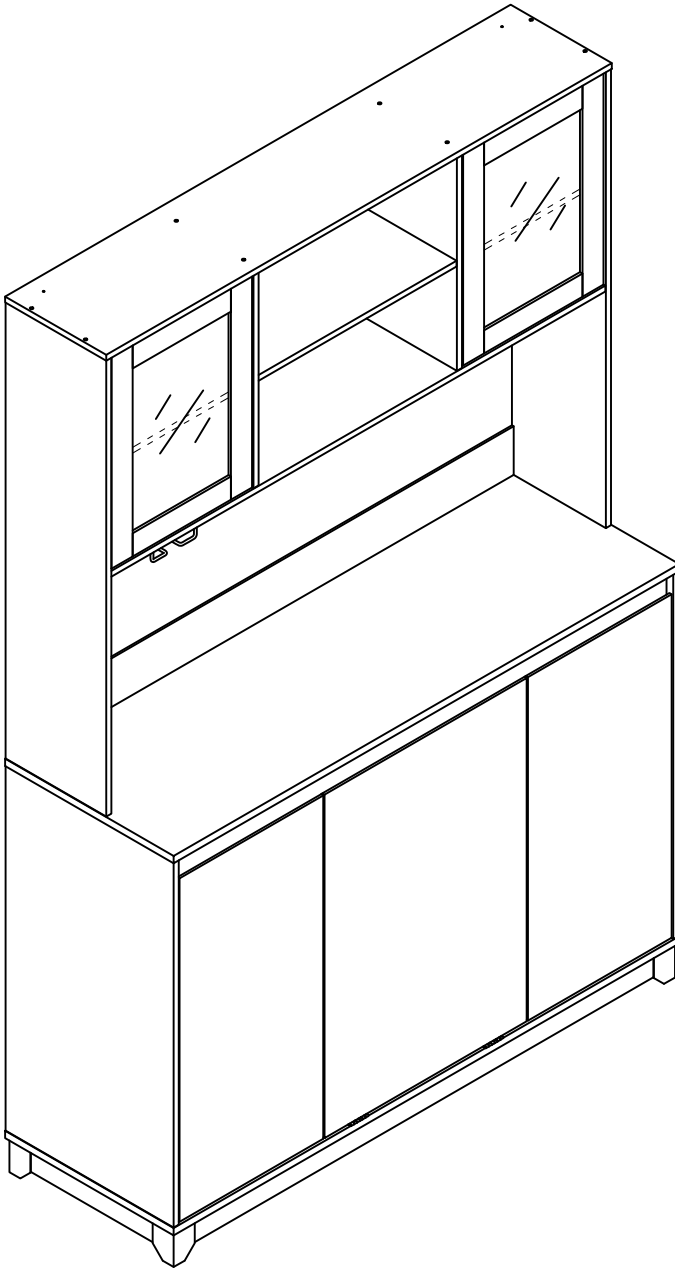

Importeur	Decobus Handel GmbH
Adresse	Innungsstraße 9, 21244 Buchholz, Deutschland
Email/URL	https://www.decobusgroup.de
Hersteller	ZHANGZHOU XINZUOBIAO INDUSTRY & TRADE CO.,LTD
Address	Beidou Industrial Zone, Zhangzhou City, Fujian Province, China
Email/URL	2092167066@qq.com
Partienummer	N620P348471-N620P348472
Hergestellt in	China
EC REP	Decobus Handel GmbH Innungsstraße 9, 21244 Buchholz, Deutschland https://www.decobusgroup.de



Importeur	Decobus Handel GmbH
Adresse	Innungsstraße 9, 21244 Buchholz, Deutschland
Email/URL	https://www.decobusgroup.de
Hersteller	Shenzhen Pinchengxin Technology co., Ltd
Adresse	3rd floor, 8 building Yuanling industrial zone, No. 39 Yuanlingcun road, Shiyan
Email/URL	fosm11@foxmail.com
Partienummer	2025/08
Hergestellt in	China
EC REP	Decobus Handel GmbH Innungsstraße 9, 21244 Buchholz, Deutschland https://www.decobusgroup.de
Produkt:	5050 RGB LED Strip Lights
Modell:	5050RGB 60D/M 5V 10MM
Nennspannung:	5V
Nennfrequenz:	60HZ
Leistung:	28W

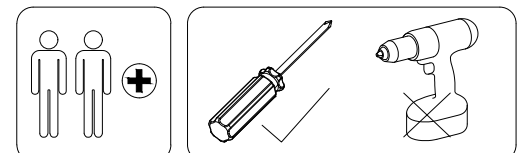
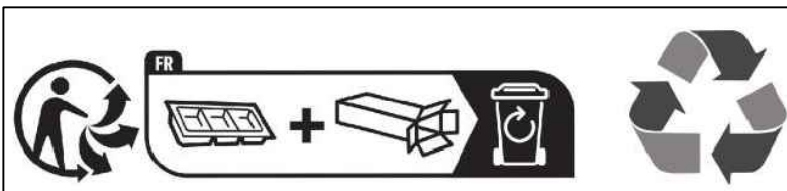

EN_IMPORTANT, RETAIN FOR FUTURE REFERENCE; READ CAREFULLY.

FR_IMPORTANT: A LIRE ATTENTIVEMENT ET A CONSERVER POUR CONSULTATION ULTERIEURE.

ES_IMPORTANTE, LEA Y GUARDE PARA FUTURAS REFERENCIAS.

DE_„WICHTIG! SORGEALTIG LESEN UND FÜR SPÄTER NACHSCHLAGEN AUFBEWAHREN.“

IT_IMPORTANTE! CONSERVARE IL PRESENTE MANUALE PER FUTURO RIFERIMENTO E LEGGERLO ATTENTAMENTE.

EN

Dear customer,

Thank you for purchasing this product. So that your appliance serves you well, please read all the instructions in this user's manual. If you have any questions, please contact our customer care center.

FR

Cher client,

Nous vous remercions d'avoir acheté ce produit. Afin que vous puissiez profiter pleinement de votre appareil, veuillez lire toutes les instructions de ce manuel d'utilisation. Si vous avez la moindre question, veuillez contacter notre centre d'assistance à la clientèle.

DE

Sehr geehrter Kunde,

Vielen Dank, dass Sie dieses Produkt erworben haben. Damit Ihr Gerät Ihnen gute Dienste leistet, lesen Sie bitte alle Hinweise in diesem Benutzerhandbuch. Wenn Sie Fragen haben, wenden Sie sich bitte an unser Kundendienstzentrum.

ES

Queridos clientes,

Gracias por comprar este producto. Para que su electrodoméstico le sirva mejor, lea todas las instrucciones de este manual del usuario. Si tiene alguna pregunta, comuníquese con nuestro Centro de Atención al Cliente.

IT

Caro Cliente,

Grazie per aver acquistato questo prodotto. Per servirti meglio con questo apparecchio ti prego di leggere tutte le istruzioni in presente manuale utente. In caso di dubbio, si prega di contattare il nostro centro assistenza clienti.

DE

1. Die maximale Tragfähigkeit der Oberplatte beträgt 60 kg, bitte nicht überladen.
2. Lassen Sie Kinder nicht auf Möbeln klettern, da dies zu Umstürzen und schweren Verletzungen führen kann.
3. Um die Sicherheit zu gewährleisten, installieren Sie bitte gemäß der Anleitung und ziehen Sie bei Bedarf Fachleute hinzu.
4. Stellen Sie Möbel nicht in die Nähe von Feuerquellen oder heißen Gegenständen, um Brandgefahr zu vermeiden.
5. Stellen Sie Möbel nicht in feuchten Umgebungen auf, um Materialschäden zu verhindern.
6. Überprüfen Sie regelmäßig alle Verbindungs- und Befestigungselemente, um sicherzustellen, dass sie fest sitzen und Unfälle zu vermeiden.
7. Dieses Produkt ist mit einem Kipp-Schutz ausgestattet, installieren Sie diesen Schutz, um Verletzungen durch Umstürzen zu vermeiden.

UK

1. The maximum weight capacity of the top panel is 60kg; please do not overload.
2. Do not allow children to climb on furniture, as this may cause tipping and serious injury.
3. To ensure safety, please install correctly according to the instructions and seek professional assistance if necessary.
4. Do not place furniture near fire sources or hot objects to avoid fire hazards.
5. Do not place furniture in damp environments to prevent material damage.
6. Regularly check all connectors and fasteners to ensure they are secure to prevent accidents.
7. This product comes with a anti-tipping device; install this device to prevent injuries from tipping.

IT

1. La capacità massima del pannello superiore è di 60 kg; non sovraccaricare.
2. Non permettere ai bambini di arrampicarsi sui mobili, poiché ciò può causare ribaltamenti e gravi infortuni.
3. Per garantire la sicurezza, installare correttamente secondo le istruzioni e, se necessario, chiedere assistenza a professionisti.
4. Non posizionare i mobili vicino a fonti di calore o oggetti caldi per evitare rischi di incendio.
5. Non posizionare i mobili in ambienti umidi per prevenire danni ai materiali.
6. Controllare regolarmente tutti i connettori e le viti per assicurarsi che siano saldi e prevenire incidenti.
7. Questo prodotto è dotato di un dispositivo anti-ribaltamento; installare questo dispositivo per evitare infortuni da ribaltamento.

ES

1. La capacidad máxima del panel superior es de 60 kg; no sobrecargar.
2. No permita que los niños escalen los muebles, ya que esto puede causar volcaduras y lesiones graves.
3. Para garantizar la seguridad, instale correctamente según las instrucciones y busque ayuda profesional si es necesario.
4. No coloque los muebles cerca de fuentes de fuego u objetos calientes para evitar riesgos de incendio.
5. No coloque los muebles en ambientes húmedos para evitar daños en los materiales.
6. Revise regularmente todos los conectores y sujetadores para asegurarse de que estén seguros y prevenir accidentes.
7. Este producto viene con un dispositivo anti-vuelco; instale este dispositivo para prevenir lesiones por vuelcos.

NL

1. De maximale draagcapaciteit van het bovenpaneel is 60 kg; niet overbelasten.
2. Laat kinderen niet op meubels klimmen, dit kan leiden tot omvallen en ernstige verwondingen.
3. Installeer correct volgens de instructies om de veiligheid te waarborgen, en schakel indien nodig professionele hulp in.
4. Plaats meubels niet in de buurt van vuurbronnen of warme objecten om brandgevaar te voorkomen.
5. Plaats meubels niet in vochtige omgevingen om materiaalschade te voorkomen.
6. Controleer regelmatig alle verbindingen en bevestigingsmiddelen om ervoor te zorgen dat ze stevig zijn en om ongevallen te voorkomen.
7. Dit product is uitgerust met een kantelbeveiliging; installeer dit apparaat om verwondingen door omvallen te voorkomen.

SE

1. Den maximala viktkapaciteten för överpanelen är 60 kg; överbelasta inte.
2. Låt inte barn klättra på möbler, då detta kan orsaka tippning och allvarliga skador.
3. För att säkerställa säkerheten, installera korrekt enligt instruktionerna och sök professionell hjälp om det behövs.
4. Placera inte möbler nära eldkällor eller heta föremål för att undvika brandrisk.
5. Placera inte möbler i fuktiga miljöer för att förhindra skador på materialen.
6. Kontrollera regelbundet alla kopplingar och fästelement för att säkerställa att de är säkra för att förhindra olyckor.
7. Denna produkt levereras med en anti-tippanordning; installera denna anordning för att förhindra skador vid tippning.

PL

1. Maksymalne obciążenie górnej płyty wynosi 60 kg; nie przeciążaj.
2. Nie pozwól dzieciom wspinać się na meble, ponieważ może to prowadzić do przewrócenia się i poważnych obrażeń.
3. Aby zapewnić bezpieczeństwo, zainstaluj prawidłowo zgodnie z instrukcją i w razie potrzeby skorzystaj z pomocy profesjonalistów.
4. Nie stawiaj mebli w pobliżu źródeł ognia lub gorących przedmiotów, aby uniknąć ryzyka pożaru.
5. Nie stawiaj mebli w wilgotnych środowiskach, aby zapobiec uszkodzeniu materiałów.
6. Regularnie sprawdzaj wszystkie złącza i elementy mocujące, aby upewnić się, że są stabilne i aby zapobiec wypadkom.
7. Produkt ten jest wyposażony w urządzenie zapobiegające przewróceniu; zainstaluj to urządzenie, aby uniknąć obrażeń w wyniku przewrócenia.

FR

1. La charge maximale du panneau supérieur est de 60 kg, ne pas surcharge.
2. Ne laissez pas les enfants grimper sur les meubles, cela peut entraîner des basculements et des blessures graves.
3. Pour garantir la sécurité, installez correctement selon les instructions et demandez l'aide de professionnels si nécessaire.
4. Ne placez pas les meubles près de sources de chaleur ou d'objets chauds pour éviter les risques d'incendie.
5. Ne placez pas les meubles dans des environnements humides pour éviter d'endommager les matériaux.
6. Vérifiez régulièrement tous les connecteurs et les fixations pour vous assurer qu'ils sont bien serrés et éviter les accidents.
7. Ce produit est équipé d'un dispositif anti-basculement; installez ce dispositif pour éviter les blessures dues au basculement.

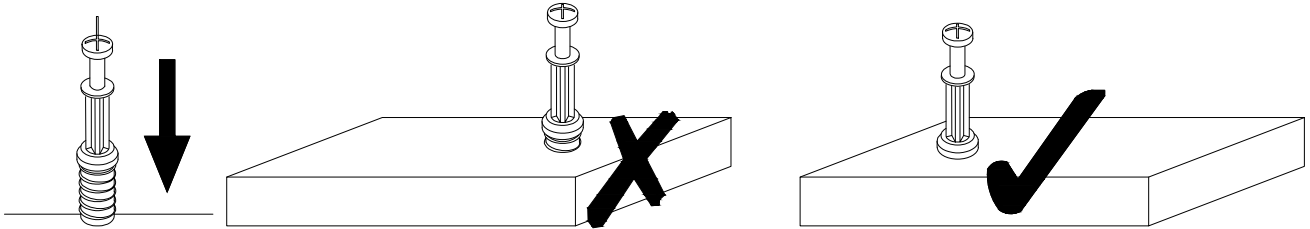

EN_QUICKFIT:Tighten quickfit until shoulder is flush with panel.Do not overtighten or undertighten.

FR_RACCORD RAPIDE:Faites serrer le raccord rapide jusqu'a ce que l'epaulement soit parfaitement encstre dans le panneau.Il ne faut ni trop serrer ni insuffisamment serrer.

ES_QUICKFIT:Apriete quickfit hasta que el hombro se descargue con el panel.NO lo sobreapriete ni lo apriete poco.

DE_QUICKFIT:Ziehen Sie den quickfit fest,bis die Schulter mit der Platte bundig ist. Bitte nicht zu fest oder zu schwach anziehen.

IT_MONTAGGIO RAPIDO:Stringere il montaggio rapido fino aquando la spalla e a filo con il pannello,non stringere troppo o troppo poco.

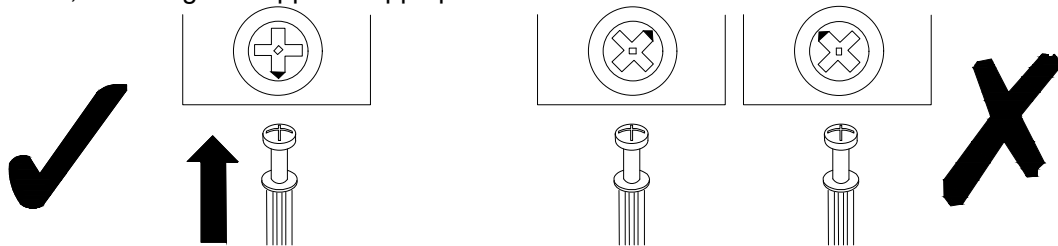

EN_CAM LOCK:When fitting cam lock,ensure starting position is correct before you insert connecting quickfit.

FR_SERRURE BATTEUSE:Avant d'insérer la serrure batteuse,veillez a la bonne orientation avant d'insérer le raccord rapide,

ES_CIERRE DE LA CAMARA:Cuando instale el cierre de la camara,asegurese de que la posicion de inicio es correcta antes de que inserte el quickfit conector,

De_CAM-LOCK:Achten Sie bei der Montage des Cam-locks auf die richtige Ausgangsposition,bevor Sie den Quickfit einsetzen.

IT_BLOCCAGGIO A CAMMA:Quando si monta il bloccaggio a camma,assicurarsi che la posizione iniziale sia corretta prima di inserire il montaggio rapido di collegamento.

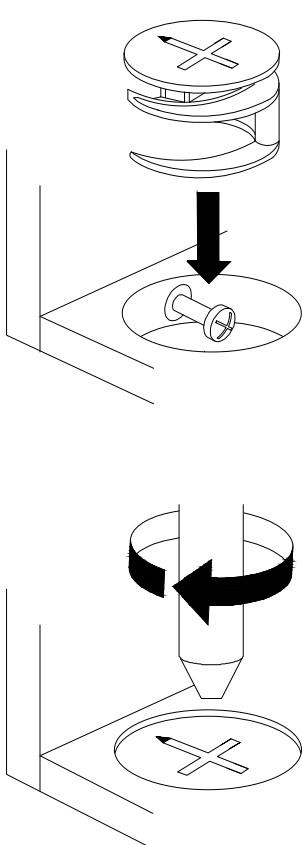

EN_Quickfit head should be in the centre of the cam lock when the two panels are joined.

Cam lock should be inserted before quickfit.

FR_Lorsque les deux panneaux sont assembles,la tete du raccord rapide doit reposer au centre de la serrure batteuse.

Il faut inserer la serrure batteuse avant le raccord rapide.

ES_EL cabezal del quickfit debe estar en el centro del cierre de la camara cuando se unan los dos paneles.

Se debe insertar el cierre de la camara antes que el quickfit.

DE_Der Quickfit-Kopf sollte sich in der Mitte des Cam-locks befinden,wenn die beiden Platten zusammengefügt sind.

Der Cam-lock sollte vor dem Quickfit eingesetzt werden.

IT_La testa del montaggio rapido deve trova rsi al centro del bloccaggio a camma quando i due pannelli sono uniti.

Il Bloccaggio a Camma deve essere inserito prima del montaggio rapido.

EN_Turn cam lock clockwise to tighten.

FR_Faites tourner la serrure batteuse dans le sens des aiguilles d'une montre pour la resserrer.

ES_Gire el cierre de la camara en sentido horario para apretarlo.

DE_Drehen Sie den Cam-Lock im Uhrzeigersinn,um ihn festzuziehen.

IT_Rutotare il bloccaggio a camma in senso oragio per stringere.

EN_ It may be necessary to adjust the hinges so that the doors align. Use the instructions below as a guide.

FR_ Il est parfois necessaire d'ajuster les charnieres pour un meilleur alignement des portes. Servez-vous des instructions ci-dessous comme guide.

ES_ Puede que sea necesario ajustar los quicios de forma que se alineen las puertas. Use las instrucciones que aparecen debajo como guia.

DE_ möglicherweise müssen Sie die Scharniere so einstellen, dass die Türen ausgerichtet sind. Verwenden Sie die nachstehenden Anweisungen als Leitfaden.

IT_ Potrebbe essere necessario regolare le cerniere in modo che le porte siano allineate. Per fare cio attenersi alle istruzioni sottostanti.

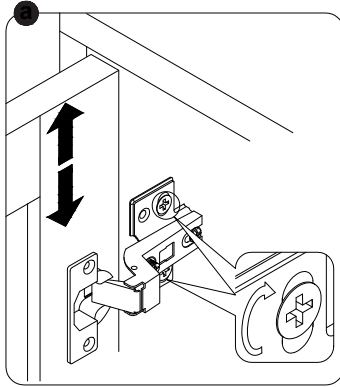

EN_ To adjust the door vertically loosen the screw as shown and move up and down as needed.

FR_ Si vous souhaitez regler la porte verticalement, desserrez la vis comme indique et deplacez la porte de haut en bas selon les besoins.

ES_ Para ajustar la puerta verticalmente afloje el tornillo tal y como se muestra y muevalo hacia arriba o hacia abajo segun sea necesario.

DE_ Um die Tür vertikal auszurichten, lösen Sie die Schraube wie abgebildet und bewegen Sie sie nach Bedarf nach oben oder nach unten.

IT_ Per allineare la porta verticalmente allentare la vite come mostrato e spostarla in alto o in basso secondo necessita.

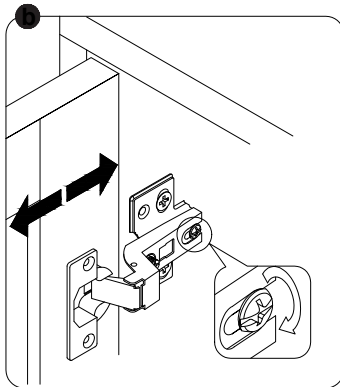

EN_ To adjust the gap from the door to the main frame turn the screw clockwise or anti-clockwise as needed.

FR_ Si vous souhaitez ajuster l'ecart entre la porte et le cadre principal, tournez la vis dans le sens des aiguilles d'une montre ou dans le sens inverse, si necessaire.

ES_ Para ajustar el espacio desde la puerta al marco principal, gire el tornillo en sentido horario o antihorario, segun se necesite.

DE_ Um den Abstand von der Tür zum Hauptrahmen auszurichten, drehen Sie die schraube ie nach Bedarf im oder gegen den Uhrzeigersinn

IT_ Per regolare lo spazio tra la porta e il telaio principale, avvitare o svitare la vite secondo necessita.

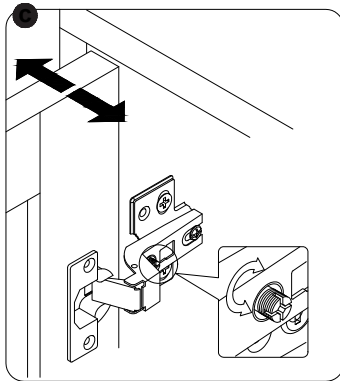

EN_ To adjust the door laterally djust the screw as shown by turning clockwise or anti-clockwise.

FR_ Si vous souhaitez ajuster la porte lateralement, ajustez la vis comme indique en tournant dans le sens des aiguilles d'une montre ou dans le sens inverse des aiguilles d'une montre.

ES_ Para ajustar la puerta laterlmente ajuste el tornillo tal y como se muestra girandolo en sentido horario y antihorario.

DE_ Um die Tür seitlich auszurichten, stellen Sie bitte die Schraube wie abgebildet durch Drehen im oder gegen den Uhrzeigersinn ein.

IT_ Per allineare la porta lateralmente regolare la vite come mostrato, avvitandola o svitandola.

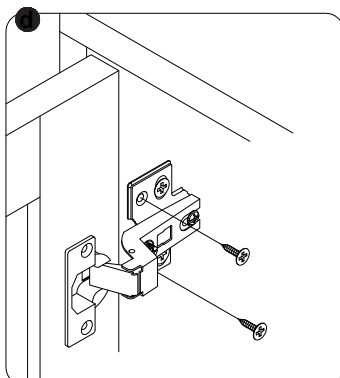

EN_ Please fix other screws

FR_ Merci de serrer les autres vis.

ES_ Fije los demas tornillos

DE_ Befestigen Sie bitte die anderen Schrauben

IT_ Fissare le altre viti

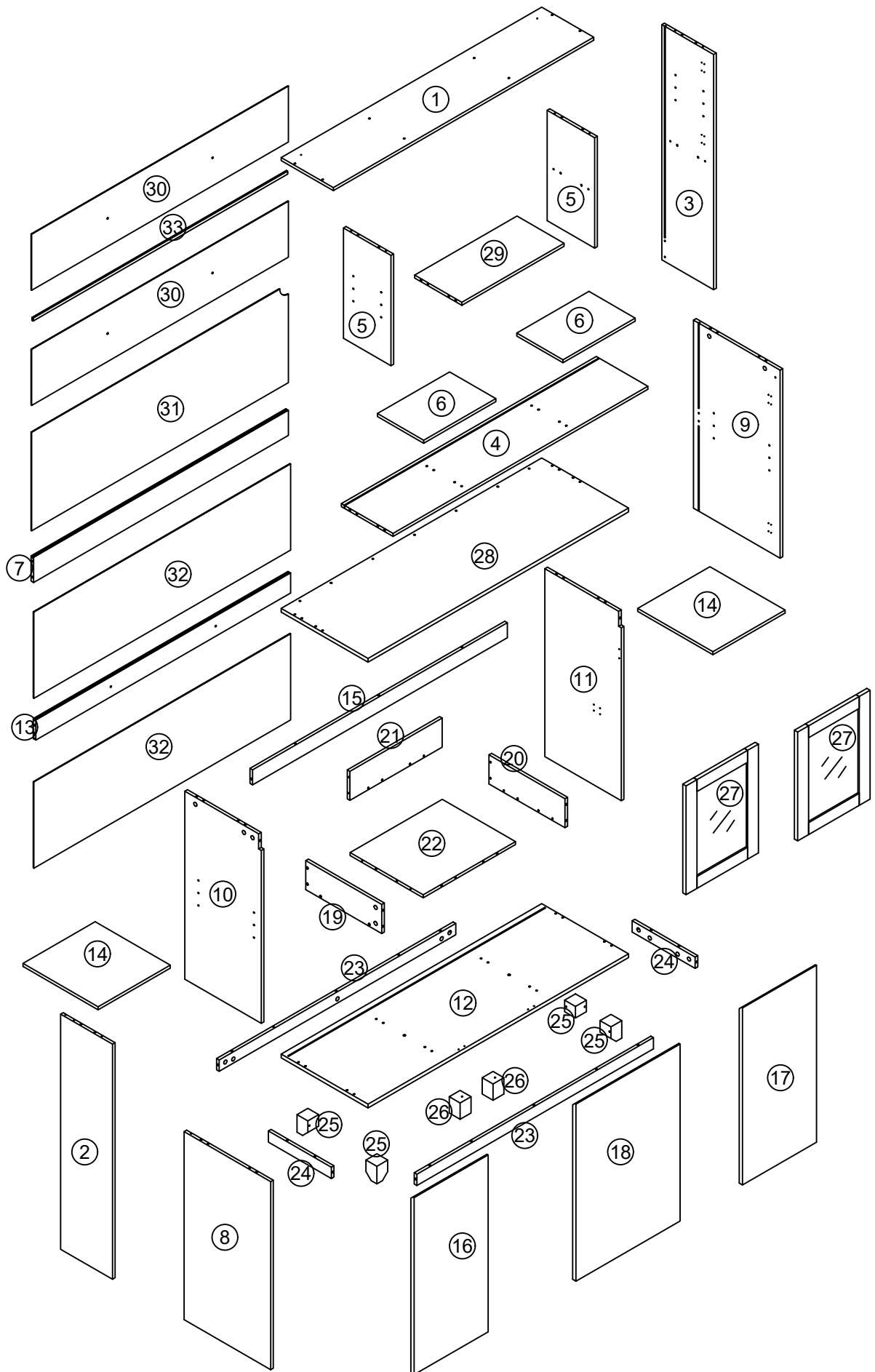

BOX-1/2 SKU N620P348472







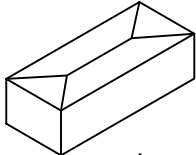

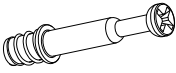

⑤ x2 	②② x1
⑧ x1 	②⑦ x2
⑨ x1 	②⑨ x1
⑩ x1 	Accessory box
⑪ x1 	②⑤ x4
⑭ x2 	②⑥ x2
⑰ x1 	
⑰ x1 	
⑱ x1 	
⑳ x1 	

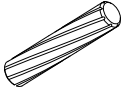
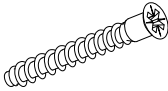
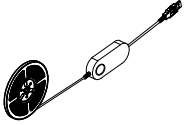
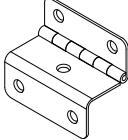
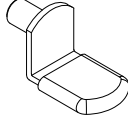
BOX-2/2 SKU N620P348471

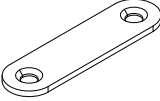
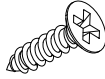
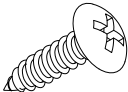
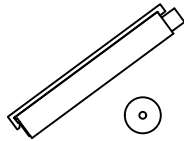
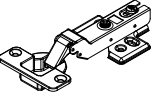
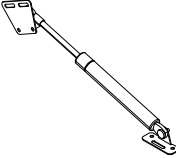
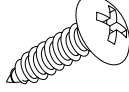
① x1 	⑳ x1
② x1 	⑳③ x2
③ x1 	⑳④ x2
④ x1 	⑳⑧ x1
⑥ x2 	⑳⑩ x2
⑦ x1 	⑳⑪ x1
⑫ x1 	⑳⑫ x2
⑬ x1 	⑳⑬ x1
⑮ x1 	
⑰ x1 	

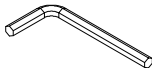
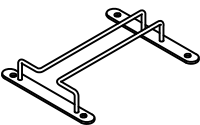
① x1 	② x1 	③ x1 	④ x1
⑤ x2 	⑥ x2 	⑦ x1 	⑧ x1
⑨ x1 	⑩ x1 	⑪ x1 	⑫ x1
⑬ x1 	⑭ x2 	⑮ x1 	⑯ x1
⑰ x1 	⑱ x1 	⑲ x1 	⑳ x1
㉑ x1 	㉒ x1 	㉓ x2 	㉔ x2
㉕ x4 	㉖ x2 	㉗ x2 	㉘ x1
㉙ x1 	㉚ x2 	㉛ x1 	㉜ x2
㉝ x1 	 Accessory box		

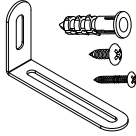
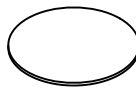
BOX-1/2 SKU N620P348472

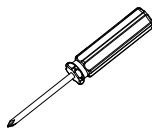
<p>A x52+4 Ø6x35mm</p> 	<p>B x52+4 Ø15x10mm</p> 	<p>C x58+4 Ø6x30mm</p> 	<p>D x42+4 Ø5x38mm</p> 	<p>E x1</p> 
<p>F x2</p> 	<p>G x16+2</p> 	<p>H x2</p> 	<p>I x2 45x12x1.3mm</p> 	<p>J x60+6 Ø7xØ3.5x12mm</p> 
<p>K x4+1 Ø6xØ3x14mm</p> 	<p>L x2</p> 	<p>M x8</p> 	<p>N x2</p> 	<p>O x4+1 Ø8xØ4x14mm</p> 
<p>P x5+1</p> 	<p>Q x4+1 M6x10mm</p> 	<p>R x1 4mm</p> 	<p>S x1</p> 	<p>T x26+2 Ø6xØ3x16mm</p> 
<p>U x2</p> 	<p>V x28+4 Ø20</p> 	<p>W x25+2 Ø6xØ3x12mm</p> 	<p>X x1</p> 	

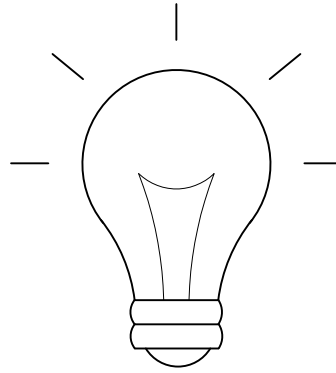

friendly reminder

To avoid errors and confusion during the installation of accessories, use the type and quantity of hardware accessories according to the installation procedure described in the instructions. First, unroll the accessories bag and lay out the hardware accessories, cut holes in the side, and take out the hardware accessories

Um Fehler und Verwirrung bei der Installation von Zubehör zu vermeiden, verwenden Sie die Art und Menge der Hardware-Zubehörteile gemäß der in der Anleitung beschriebenen Installationsprozedur. Öffnen Sie zunächst den Zubehörbeutel, breiten Sie die Hardware-Zubehörteile aus, schneiden Sie das Loch an der Seite und entnehmen Sie die Hardware-Zubehörteile

Pour éviter les erreurs et la confusion lors de l'installation des accessoires, utilisez le type et la quantité d'accessoires matériels conformément à la procédure d'installation décrite dans les instructions. Tout d'abord, déroulez le sac d'accessoires, étalez les accessoires matériels, coupez les trous sur le côté et retirez les accessoires matériels.

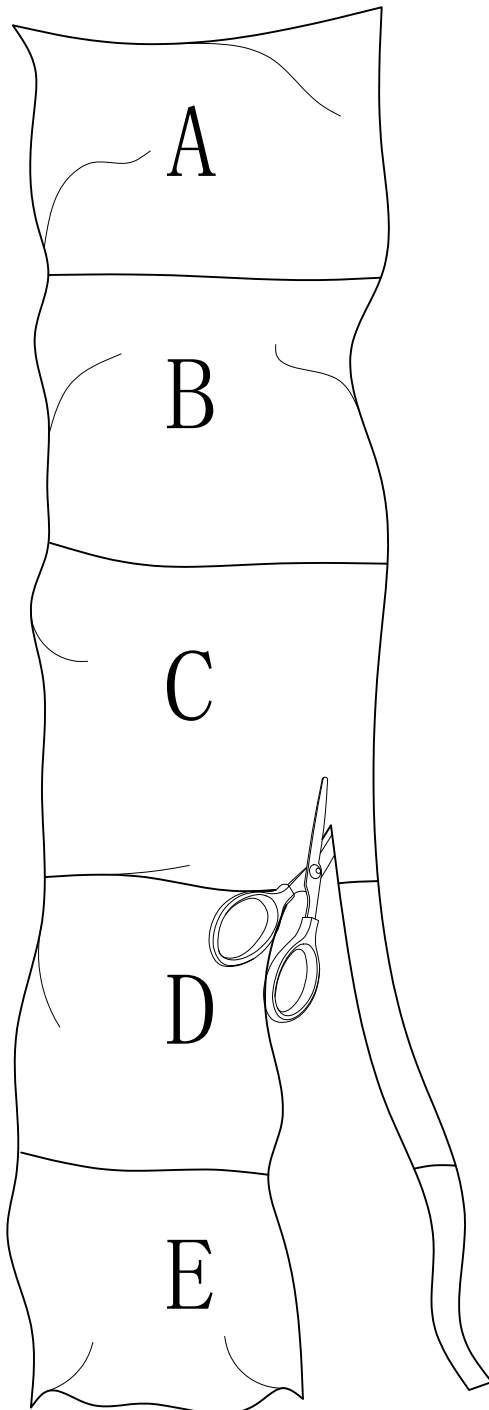

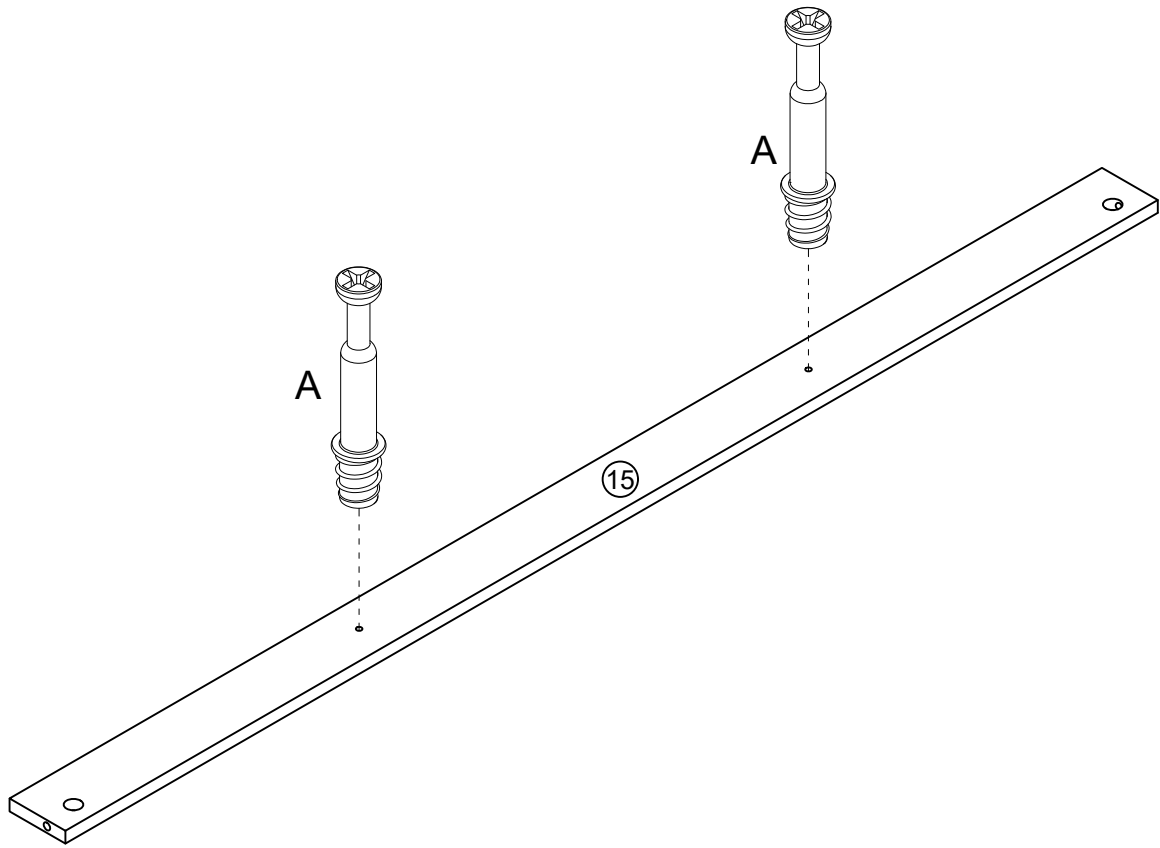

A x 2

Ø6x35mm

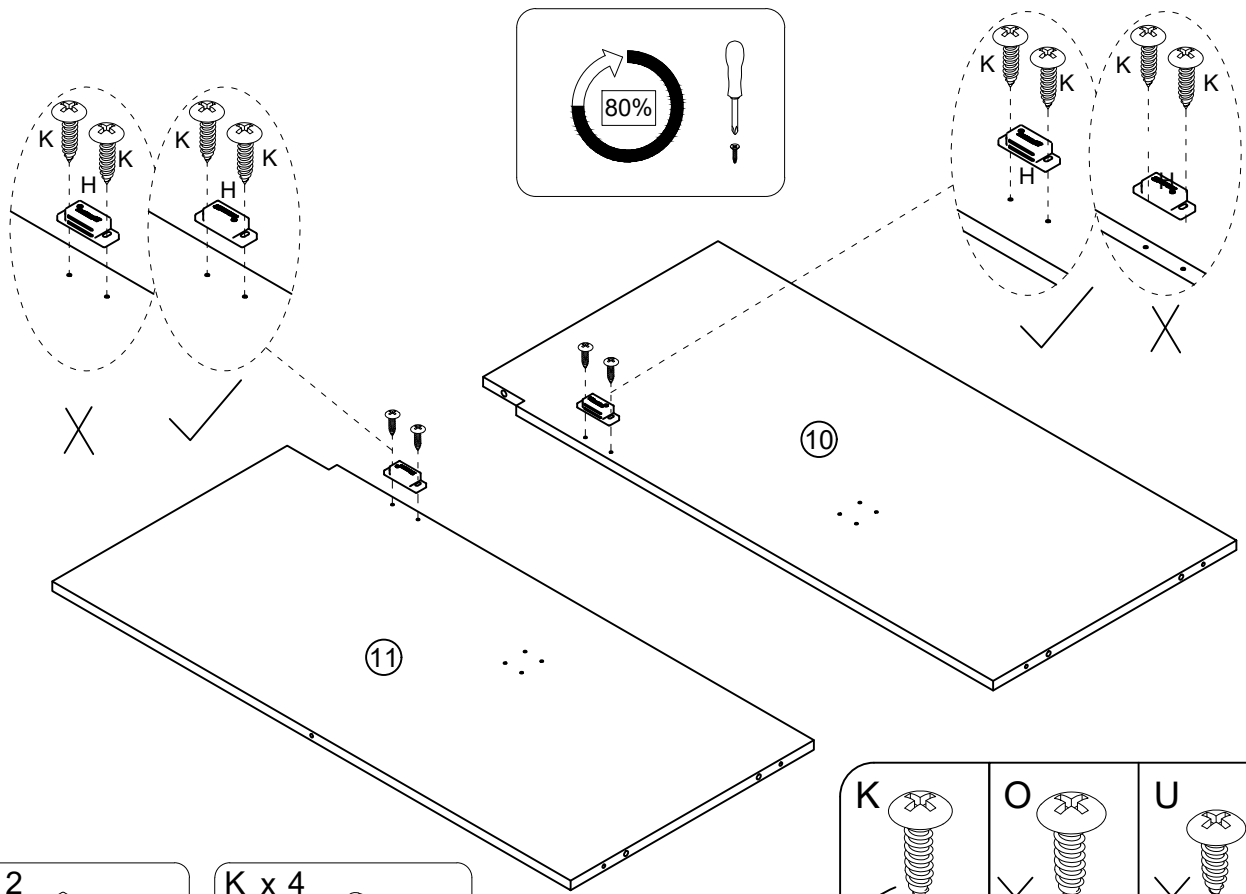

H x 2

K x 4

Ø6xØ3x14mm

K	O	U
✓	✗	✗
Ø6xØ3x14mm	Ø8xØ4x14mm	Ø8xØ4x12mm

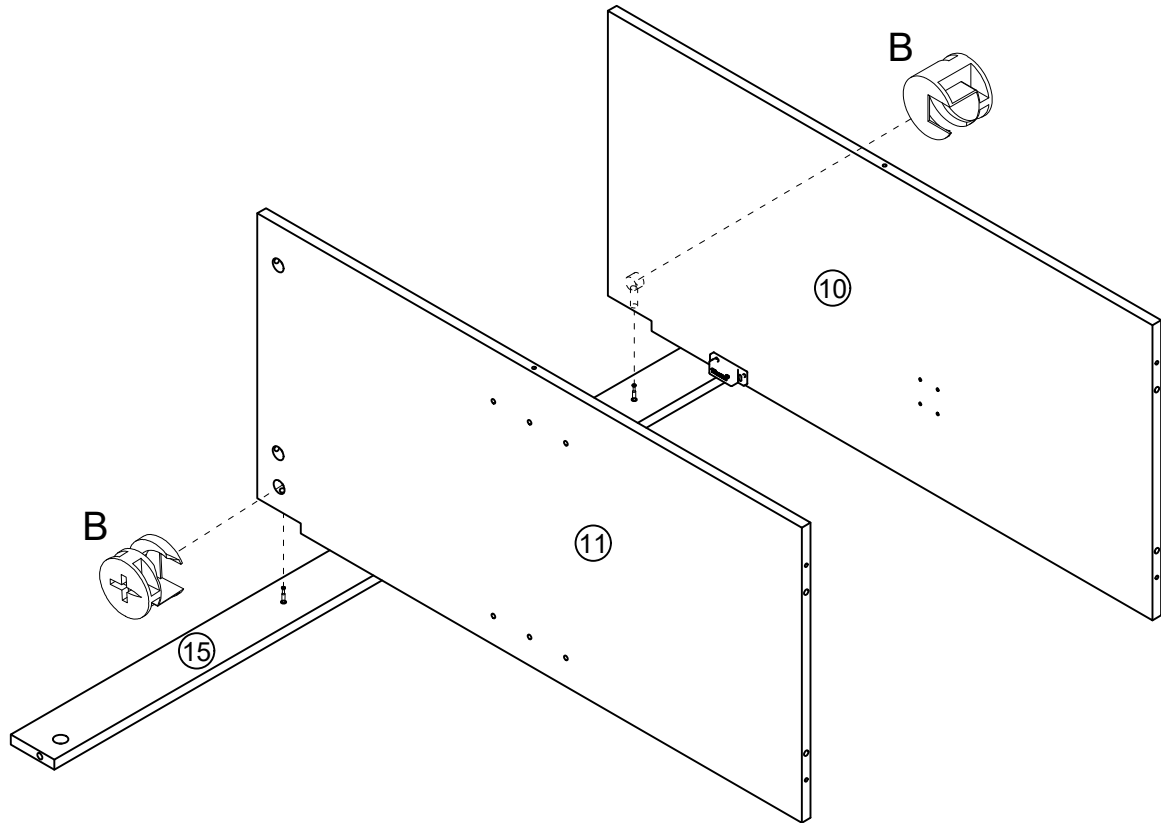

B x 2



Ø15x10mm

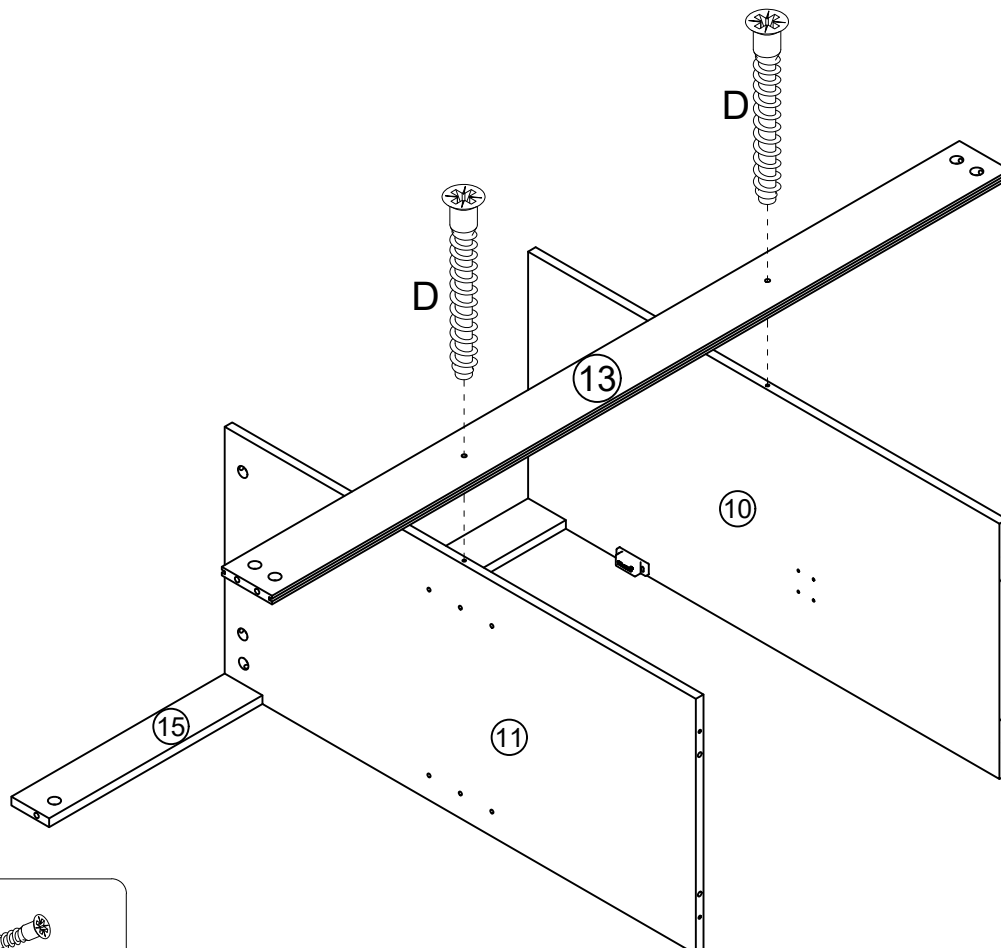

D x 2



Ø5x38mm

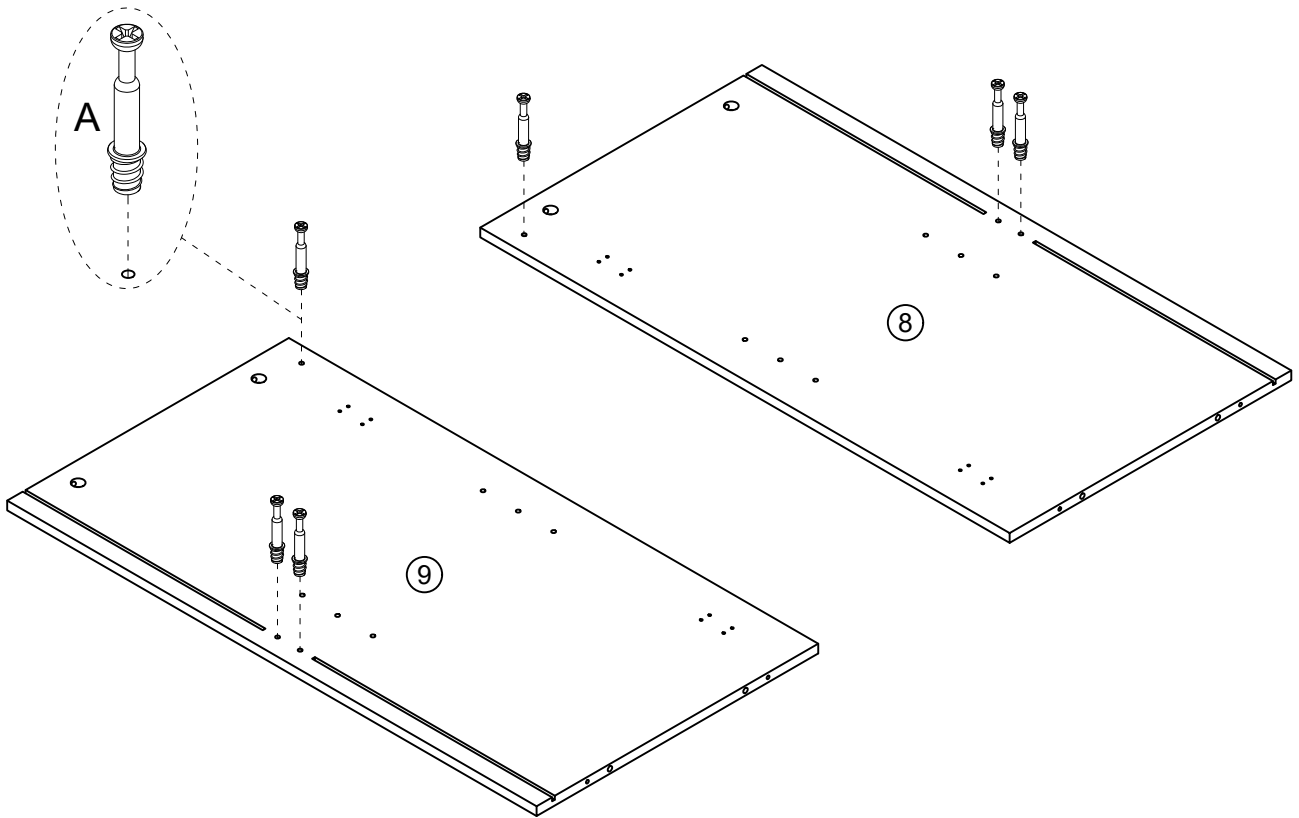

A x 6



Ø6x35mm

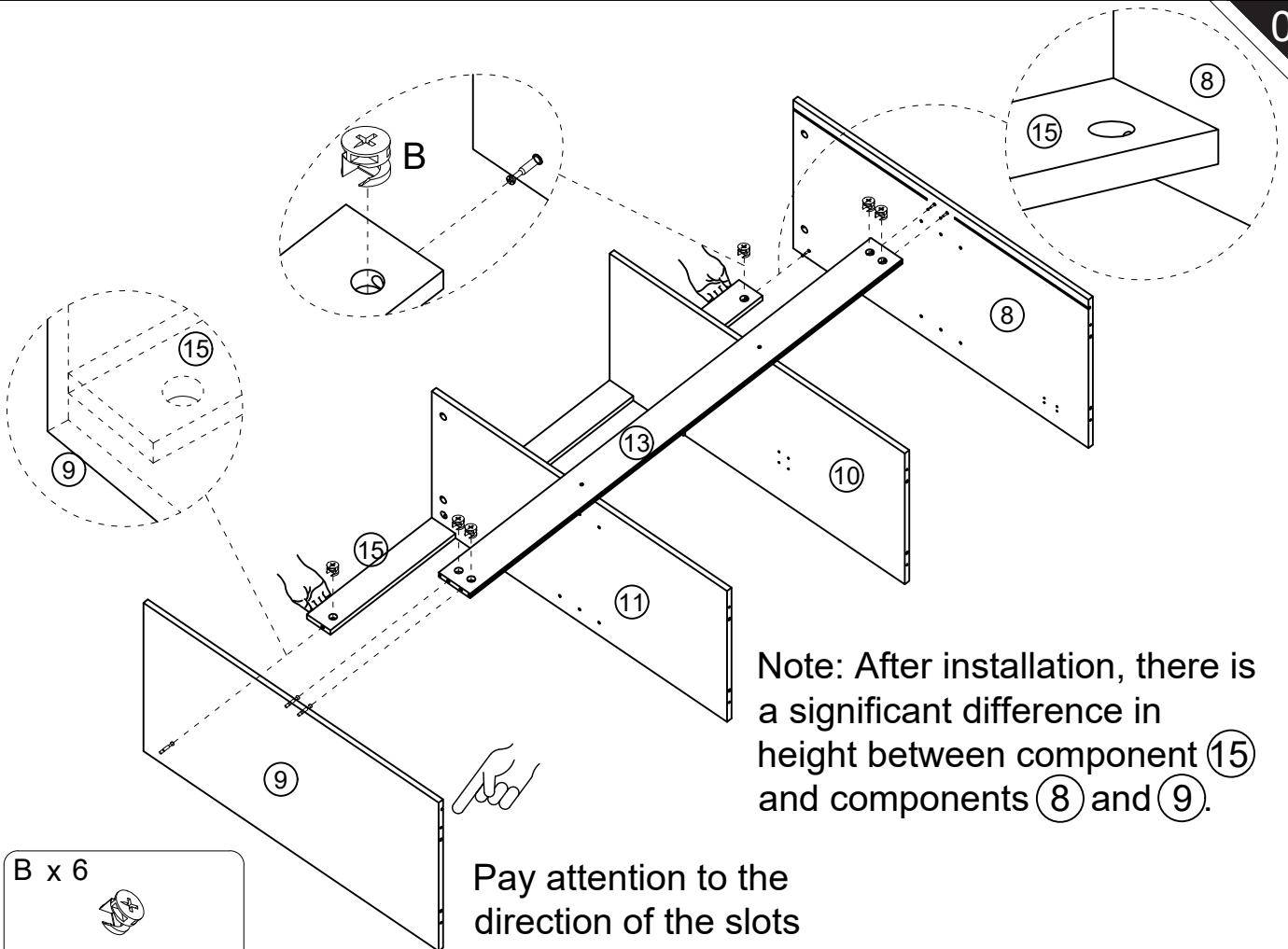

B x 6

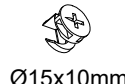

Ø6x10mm

Note: After installation, there is a significant difference in height between component 15 and components 8 and 9.

Pay attention to the direction of the slots

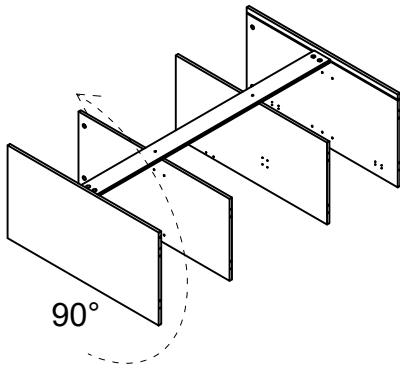

The thin plate needs to be fully inserted into the groove. If the insertion is not smooth, you can try pressing from the front or the back to make adjustments until the thin plate is fully inserted into the groove.

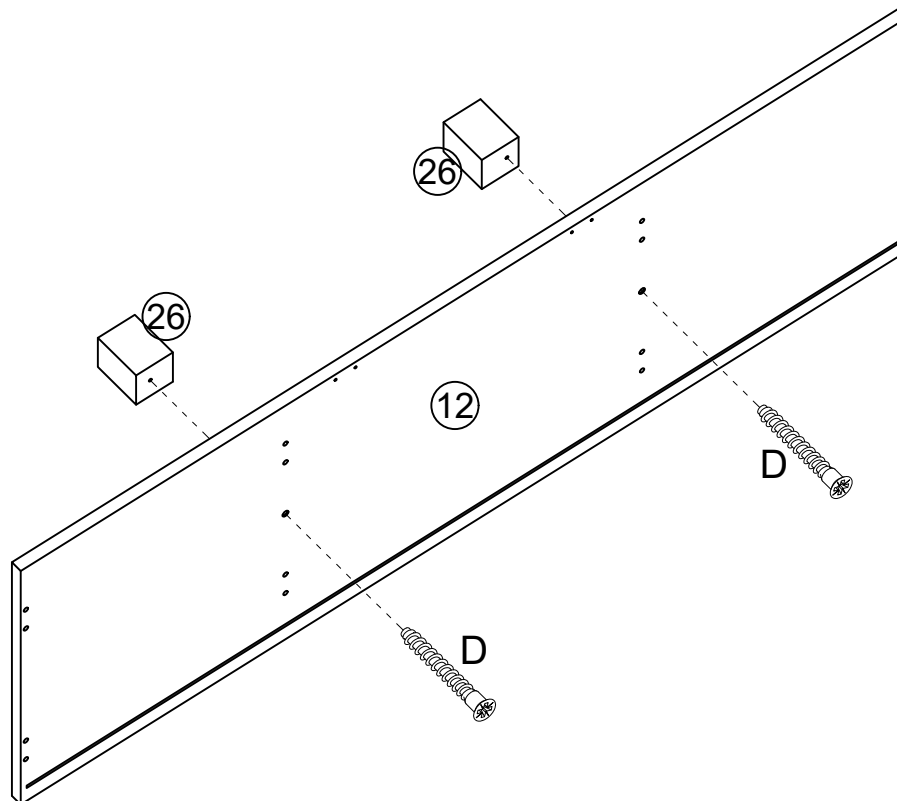
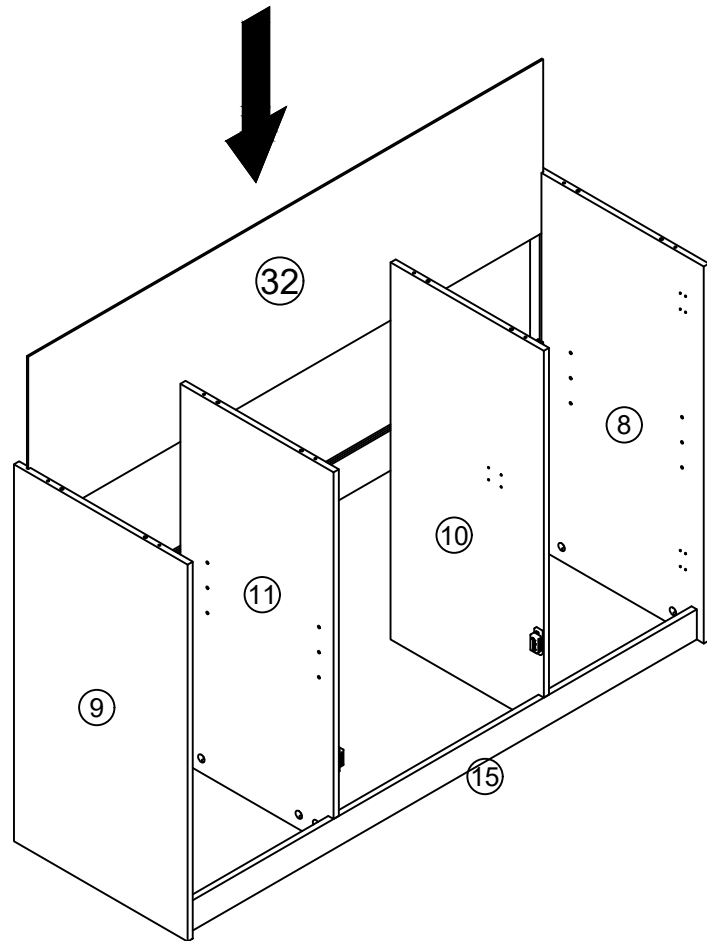

D x 2

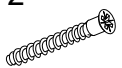

Ø5x38mm

Pay attention to the direction of the slots on the back side.

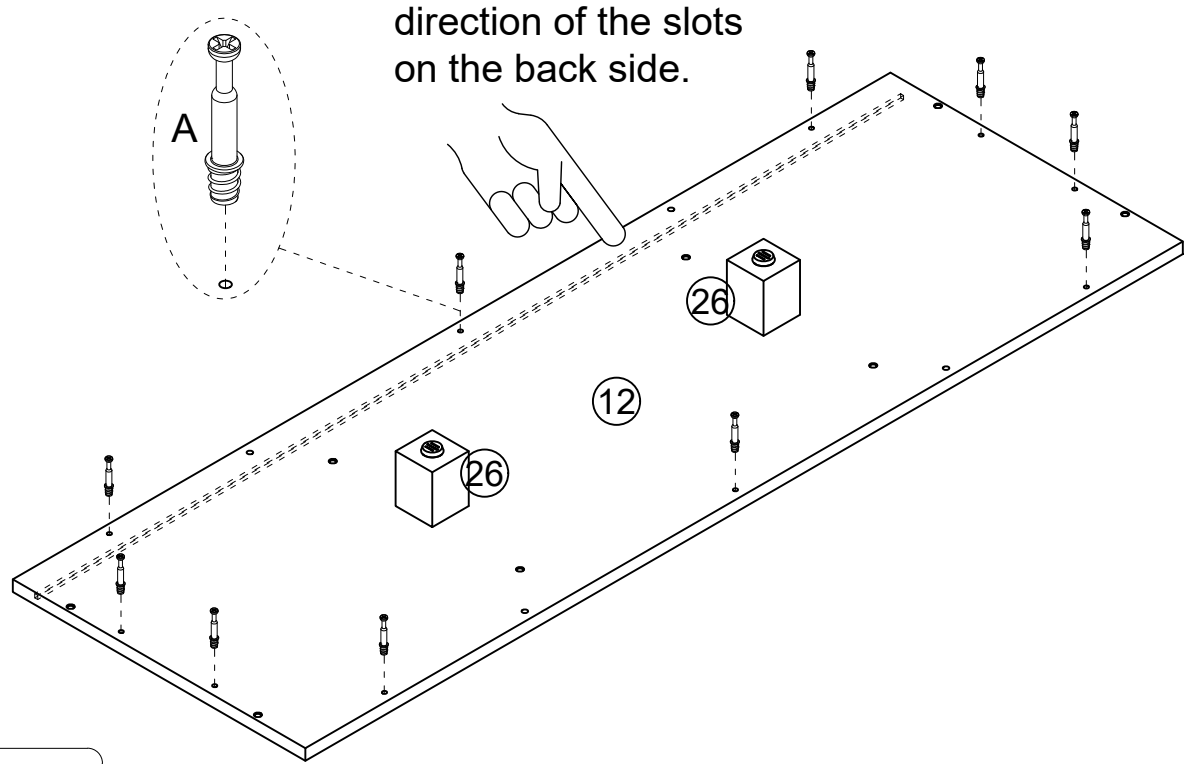

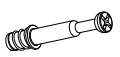
A x 10

 Ø6x35mm

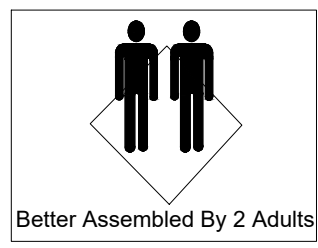
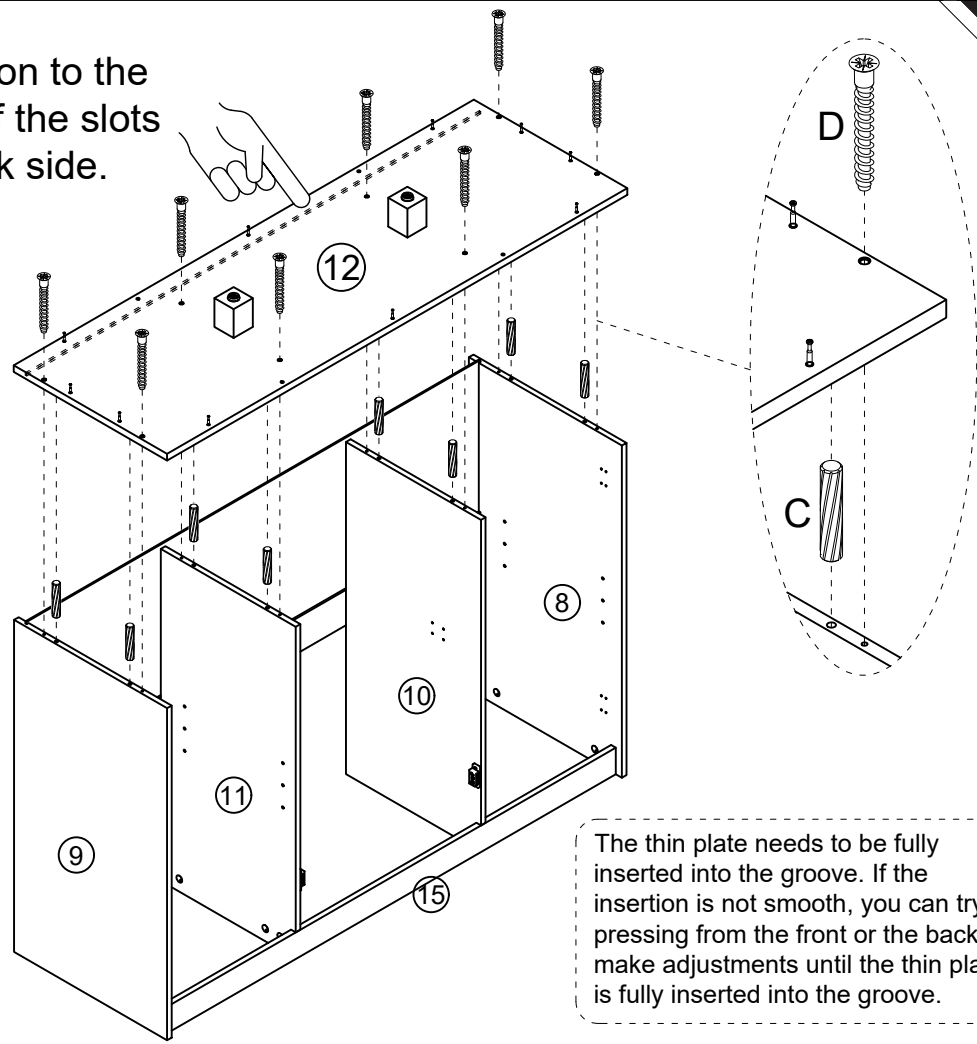
Pay attention to the direction of the slots on the back side.



C x 8

 Ø6x30mm

D x 8

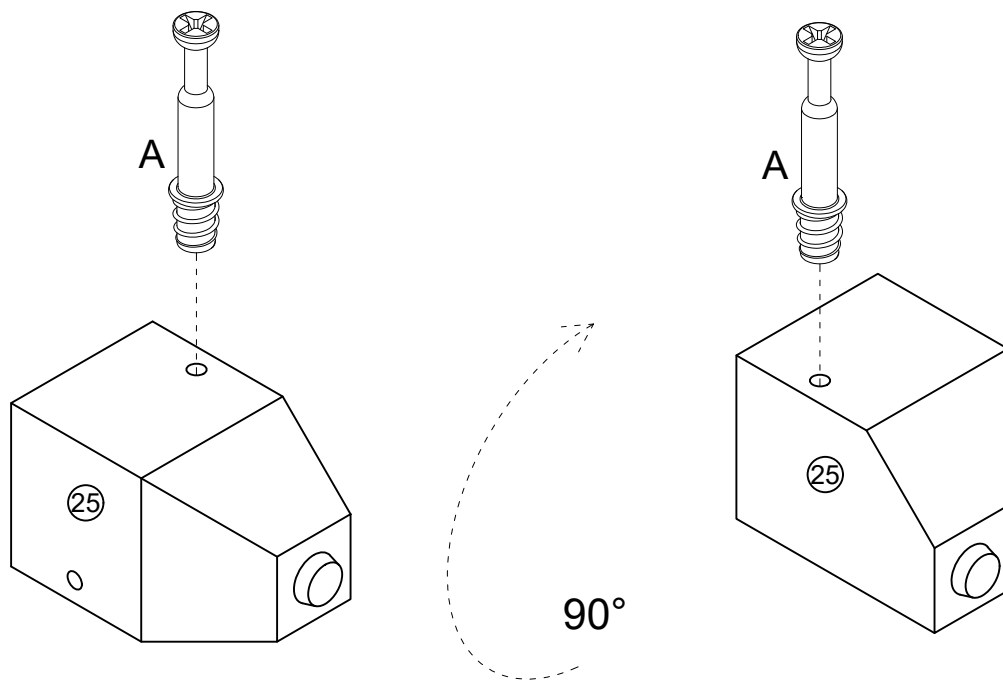
 Ø5x38mm

The thin plate needs to be fully inserted into the groove. If the insertion is not smooth, you can try pressing from the front or the back to make adjustments until the thin plate is fully inserted into the groove.

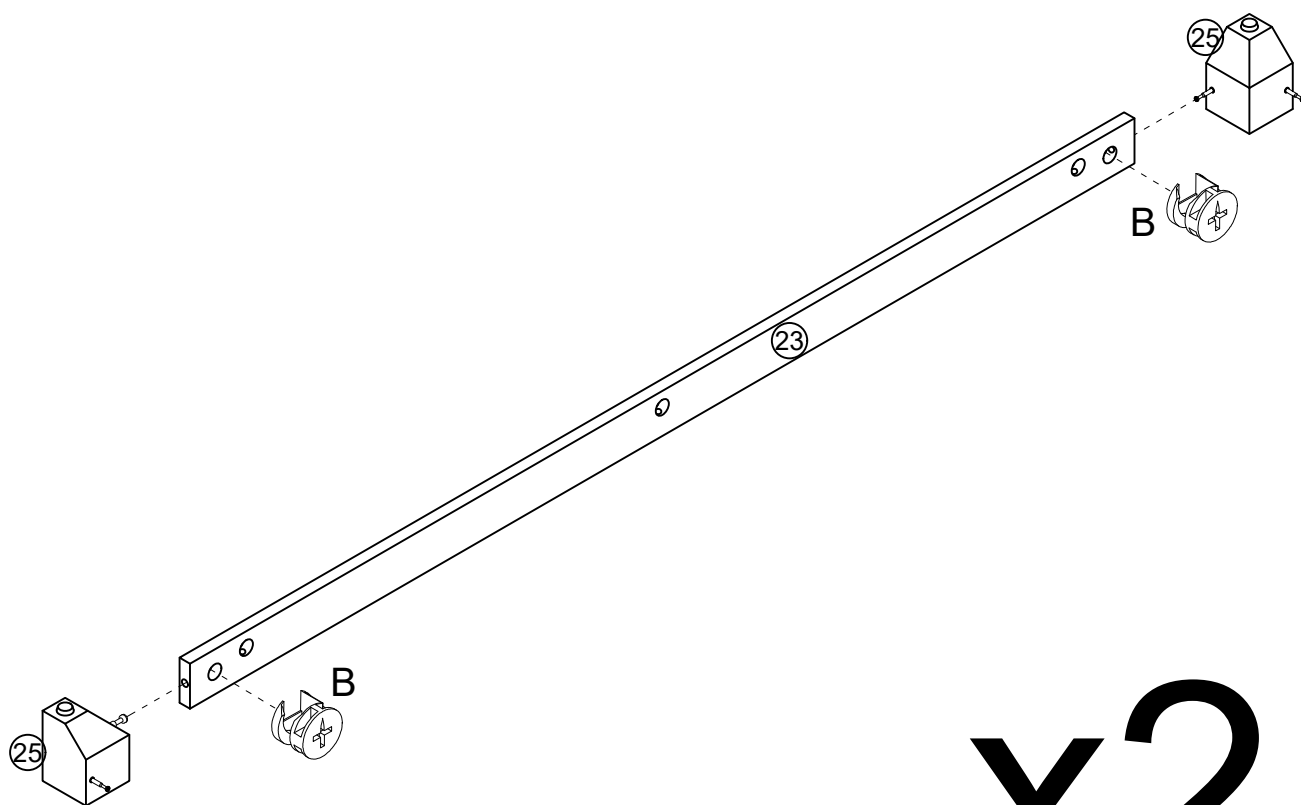
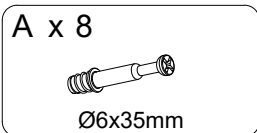



x4



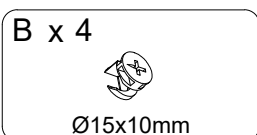

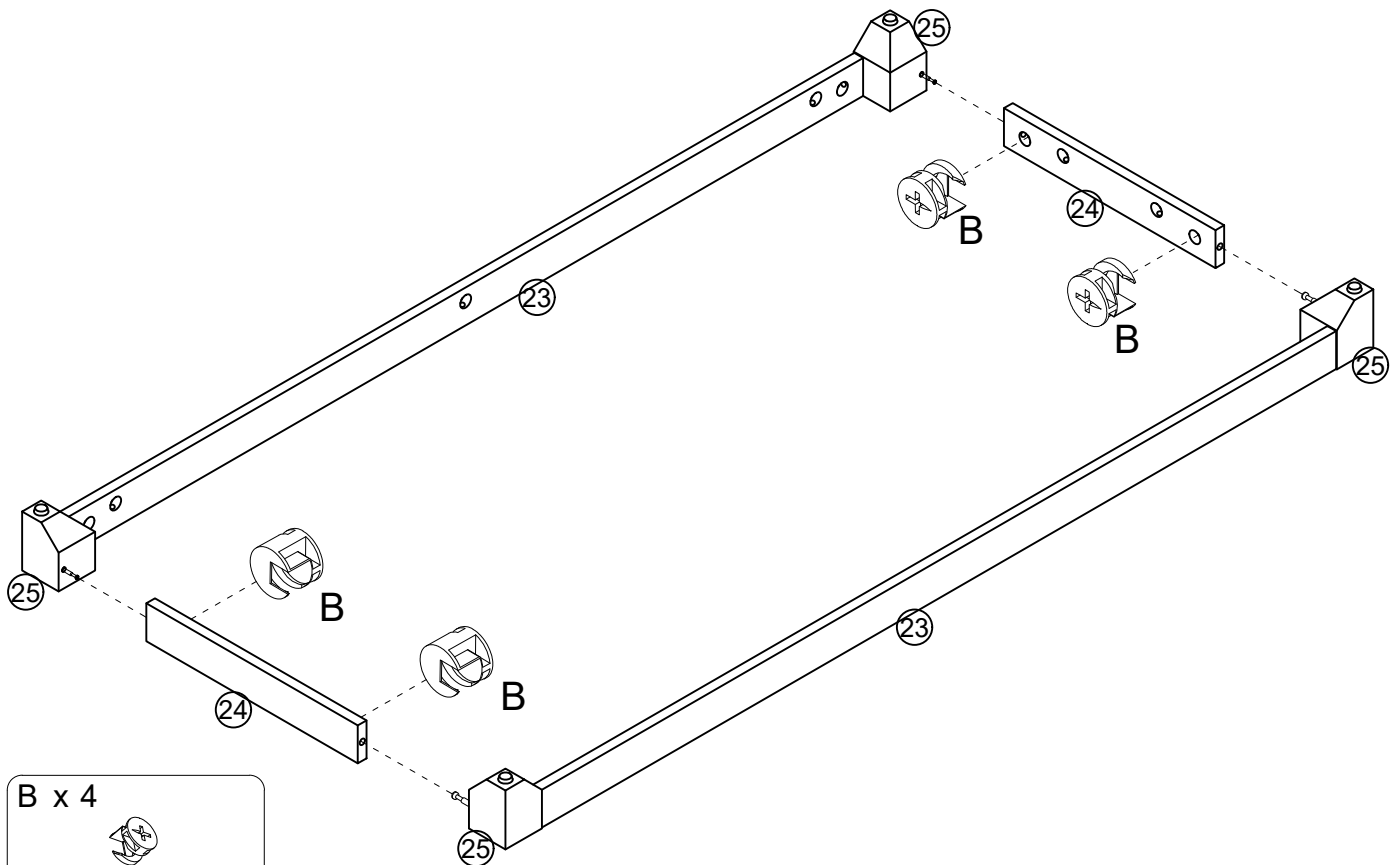
x2



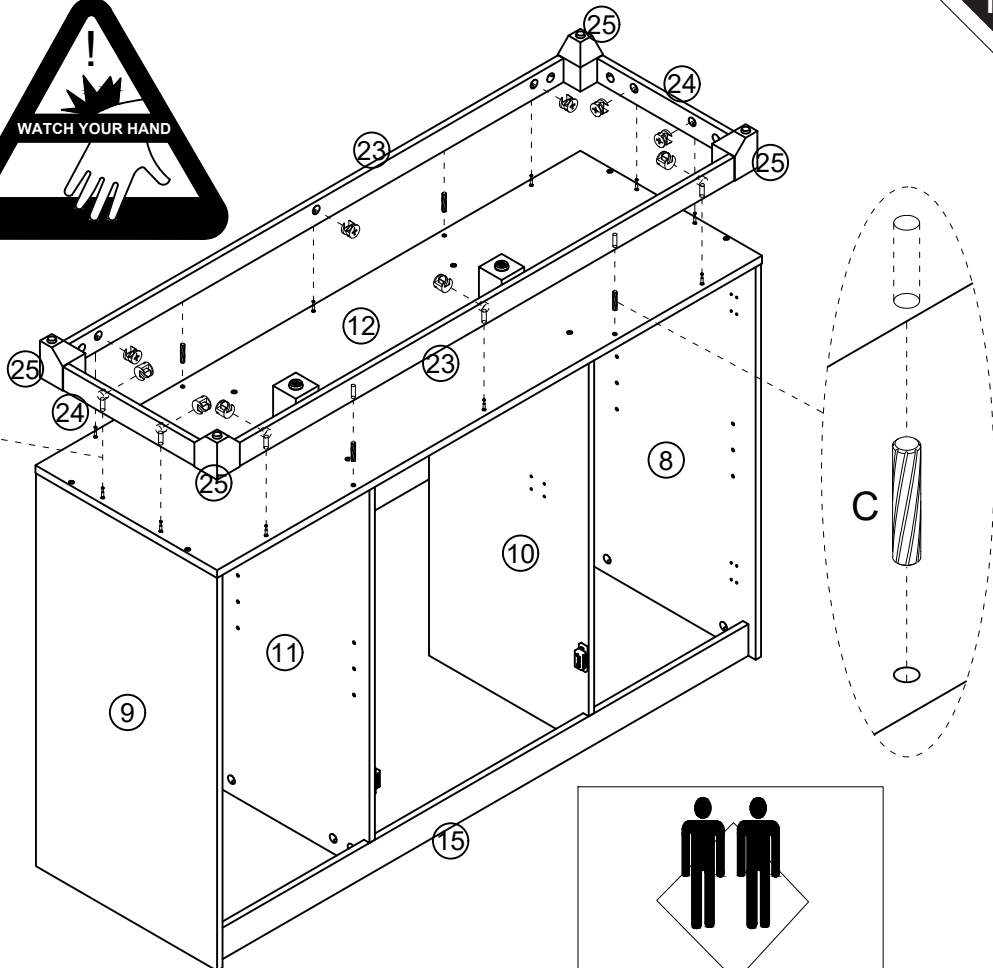
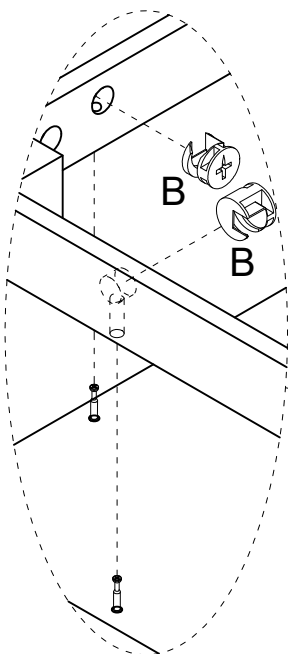

B x 4

 Ø15x10mm

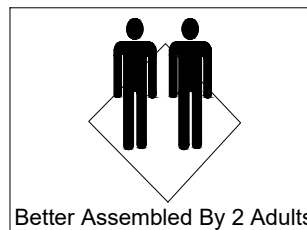

B x 10

 Ø15x10mm

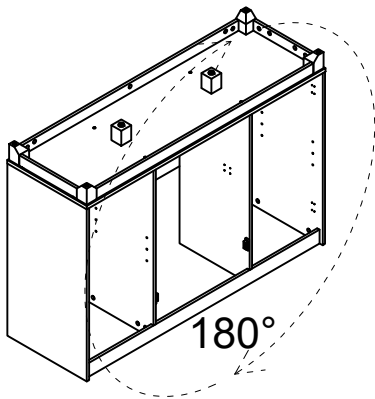
C x 4

 Ø6x30mm



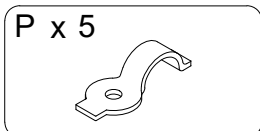
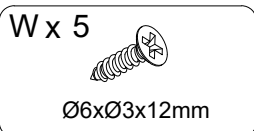
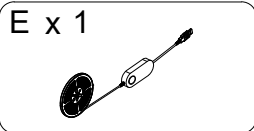
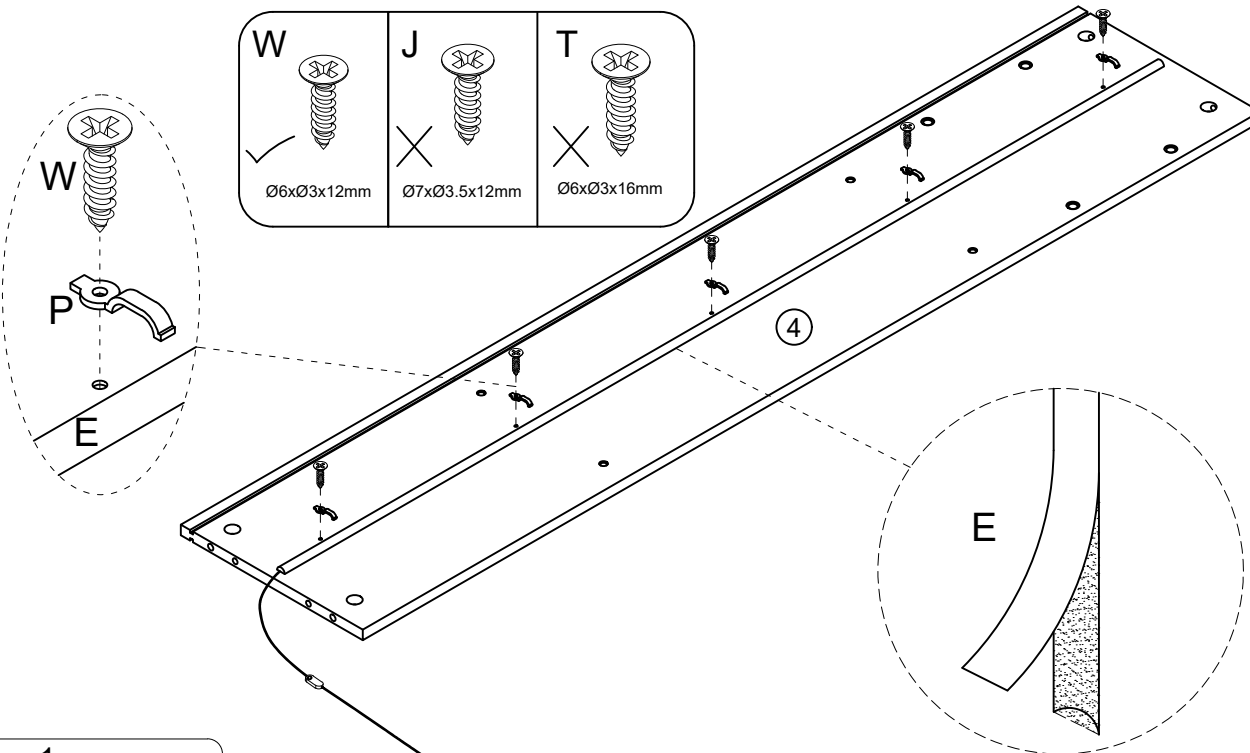
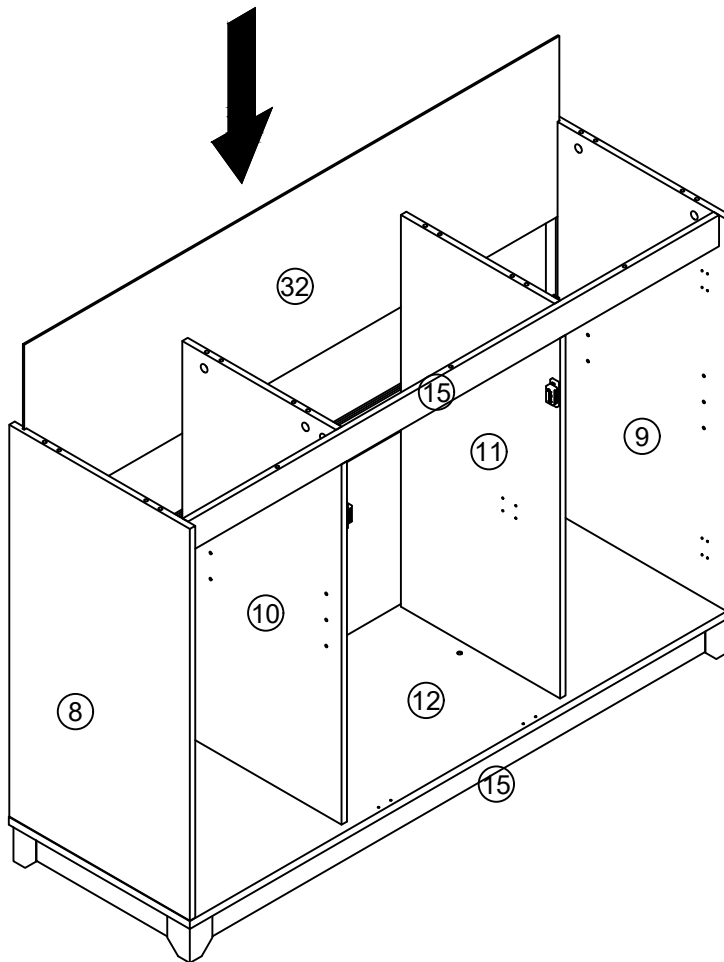
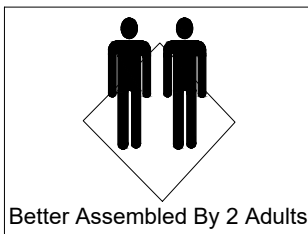

The thin plate needs to be fully inserted into the groove. If the insertion is not smooth, you can try pressing from the front or the back to make adjustments until the thin plate is fully inserted into the groove.



Please remove the film on the back of the lamp before installing the lamp strip to ensure that the lamp strip can be adhered to the board

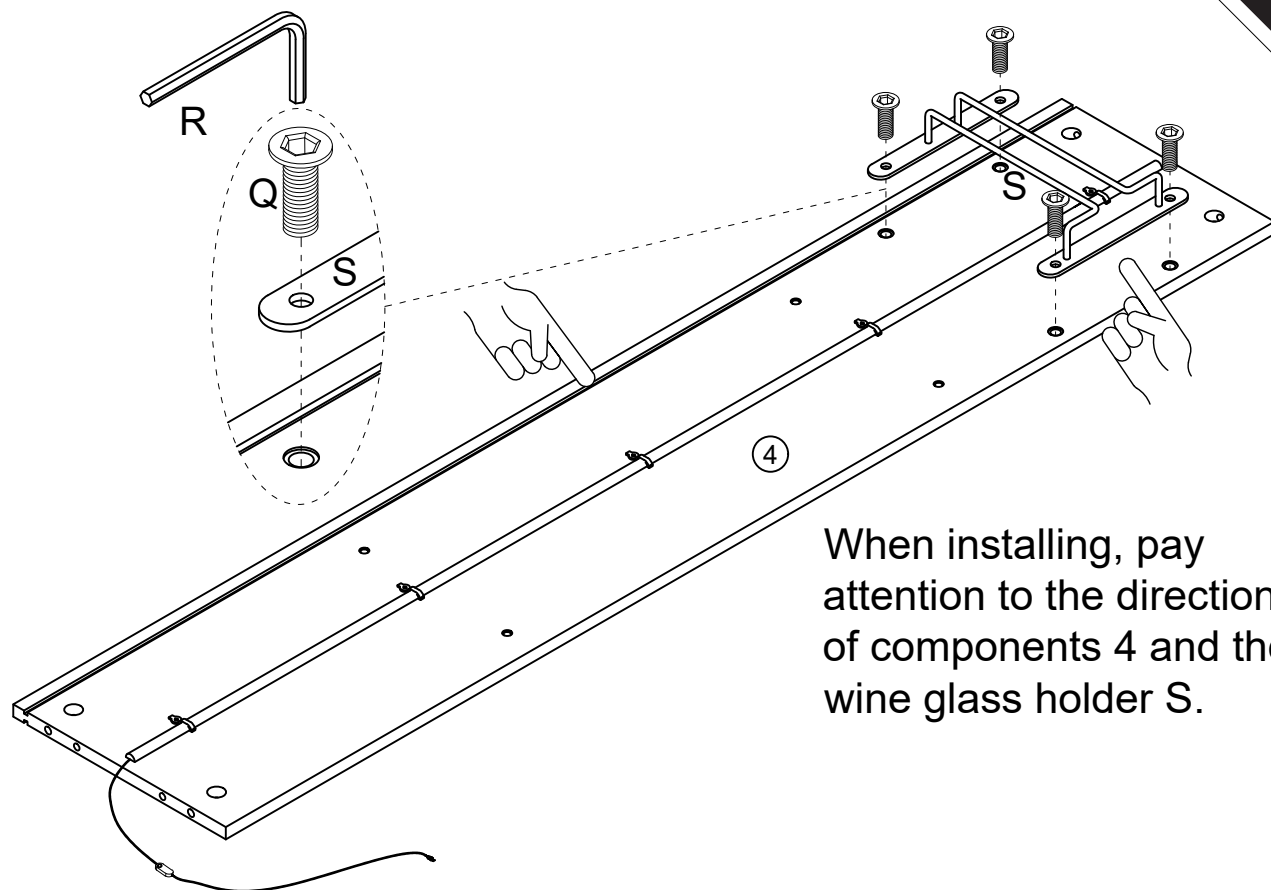

When installing, pay attention to the directions of components 4 and the wine glass holder S.

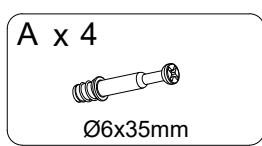
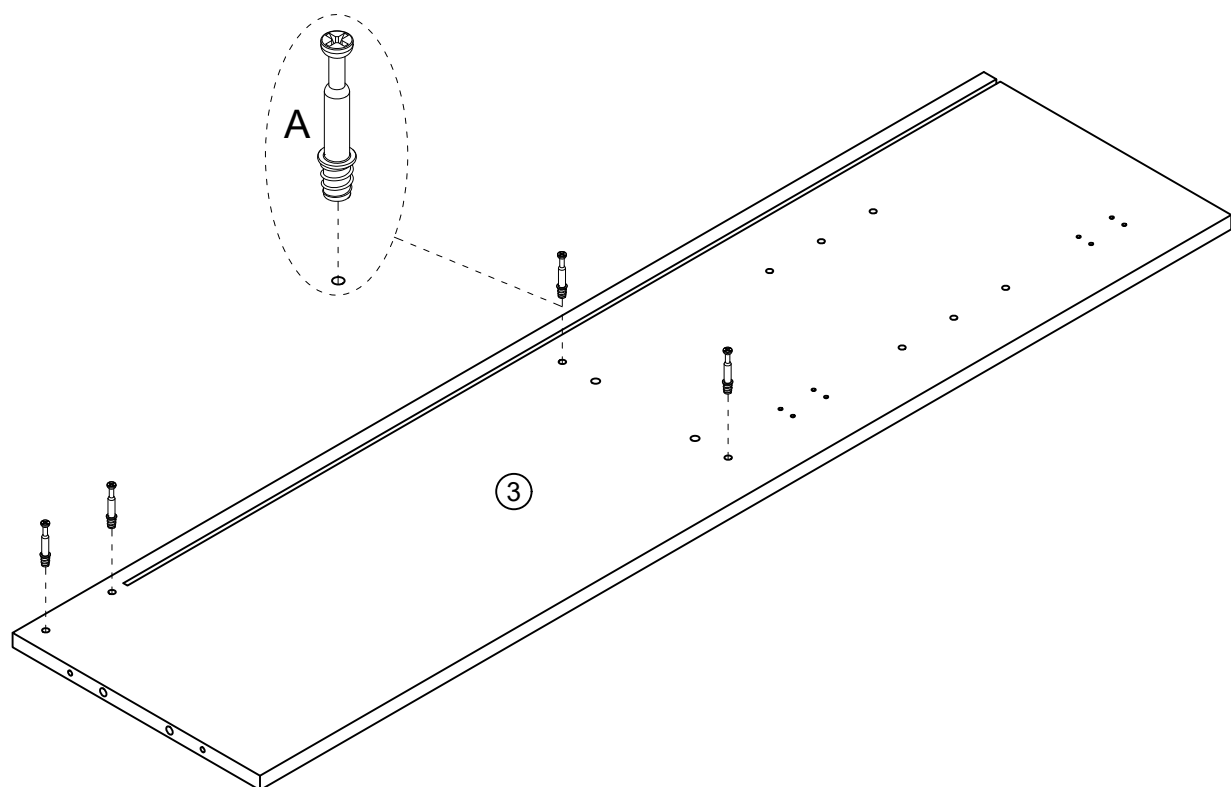
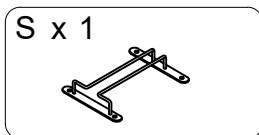
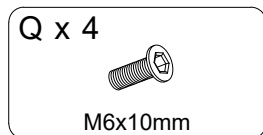
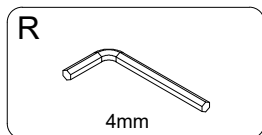

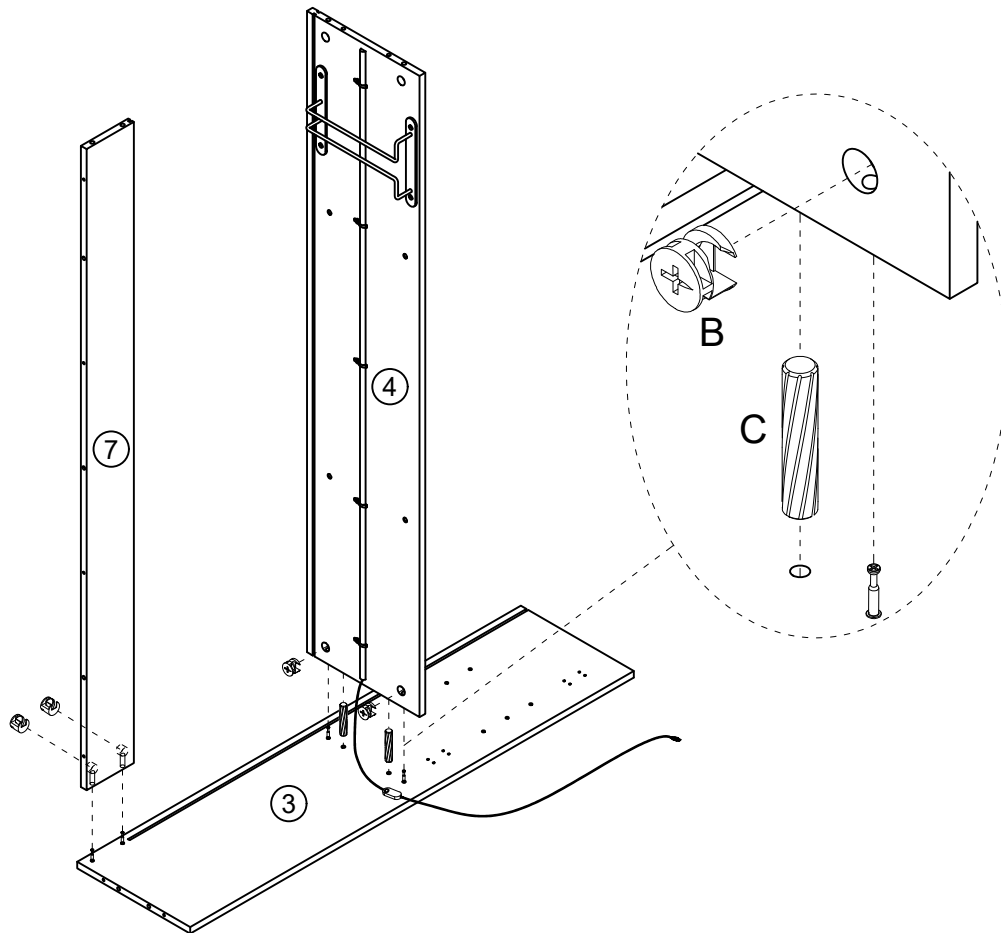

B x 4



Ø15x10mm

C x 2



Ø6x30mm

Pay attention to the direction of the gap opening.

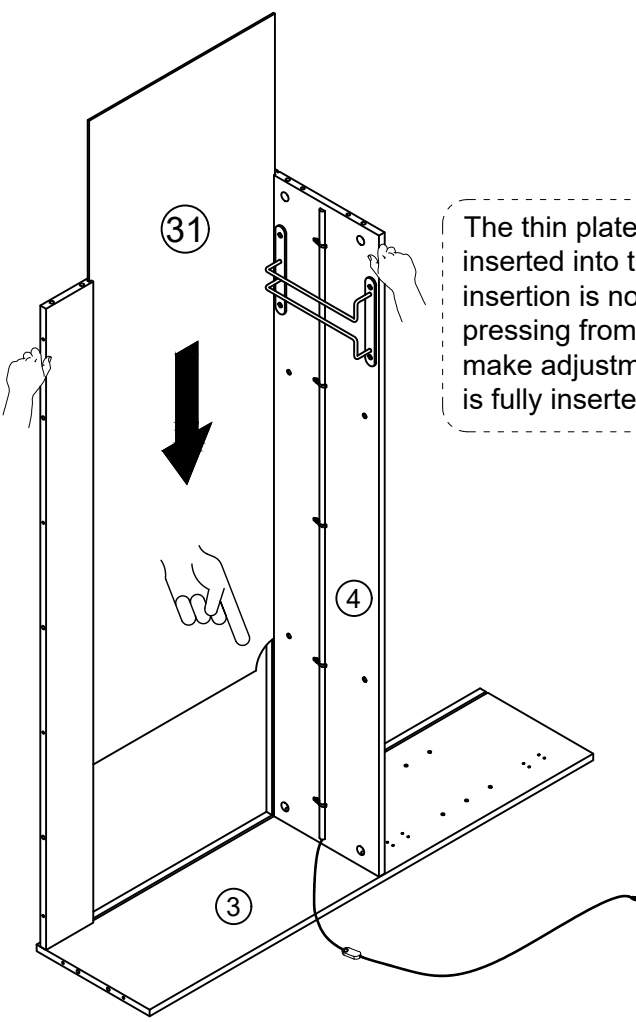

The thin plate needs to be fully inserted into the groove. If the insertion is not smooth, you can try pressing from the front or the back to make adjustments until the thin plate is fully inserted into the groove.

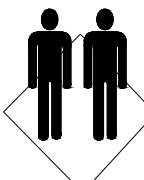

Better Assembled By 2 Adults

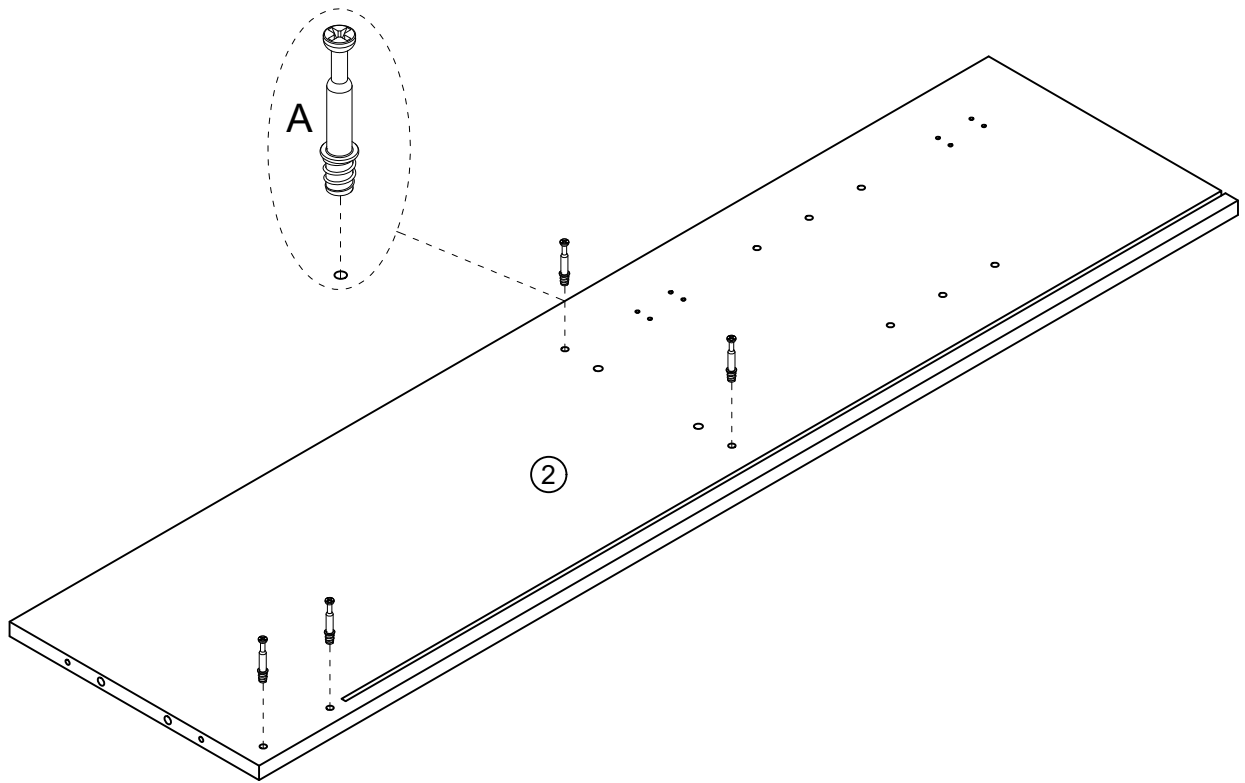

A x 4

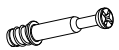

Ø6x35mm

The thin plate needs to be fully inserted into the groove. If the insertion is not smooth, you can try pressing from the front or the back to make adjustments until the thin plate is fully inserted into the groove.

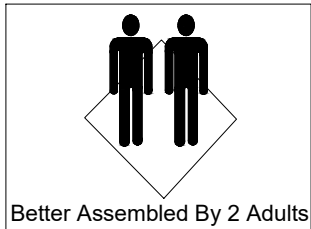

B x 4



Ø15x10mm

C x 2



Ø6x30mm

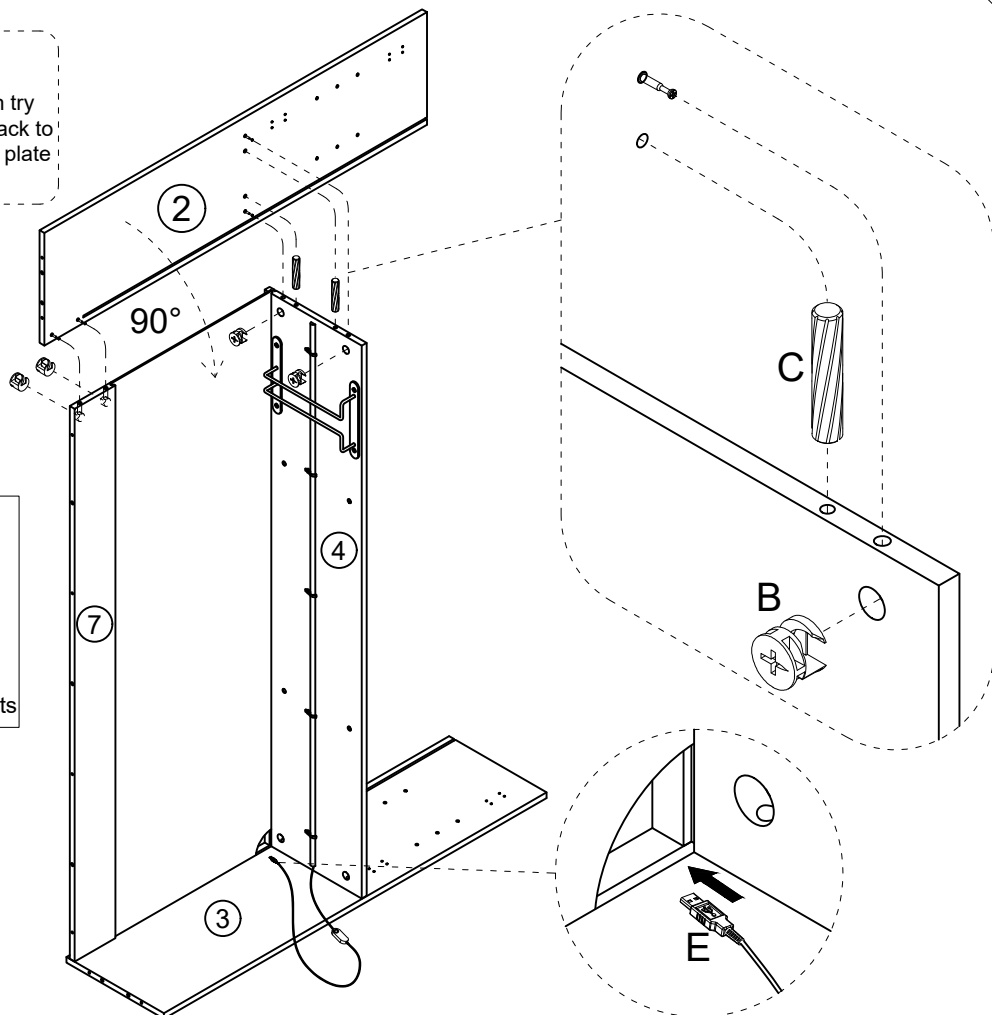

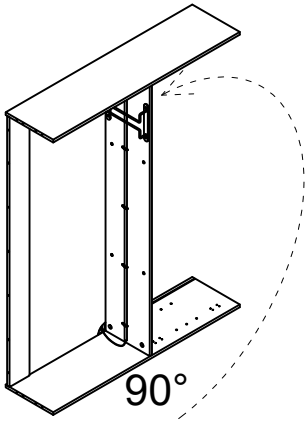

The thin plate needs to be fully inserted into the groove. If the insertion is not smooth, you can try pressing from the front or the back to make adjustments until the thin plate is fully inserted into the groove.

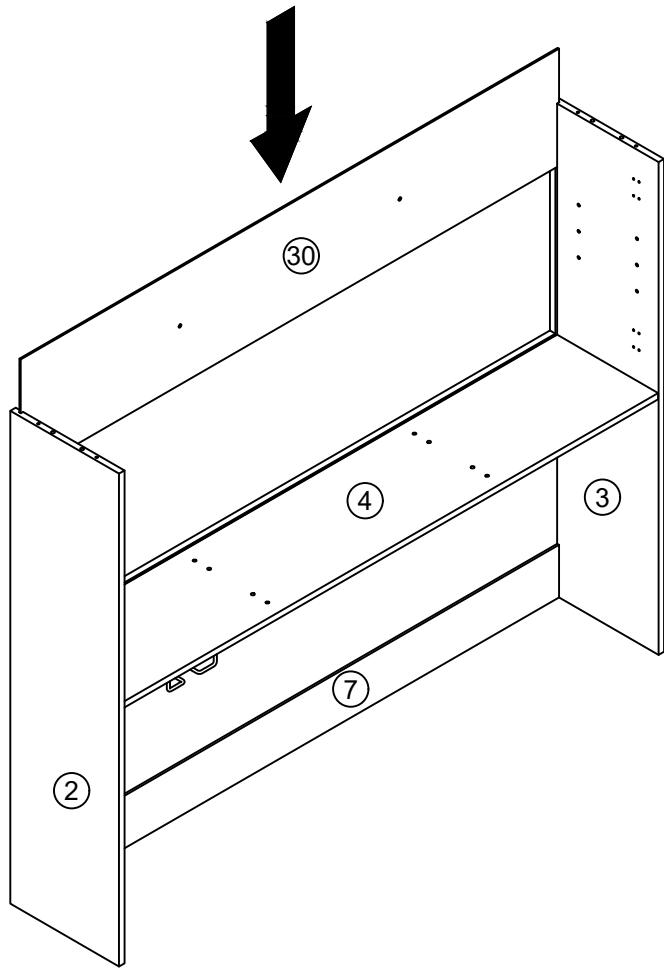
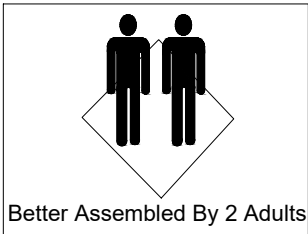

The thin plate needs to be fully inserted into the groove. If the insertion is not smooth, you can try pressing from the front or the back to make adjustments until the thin plate is fully inserted into the groove.

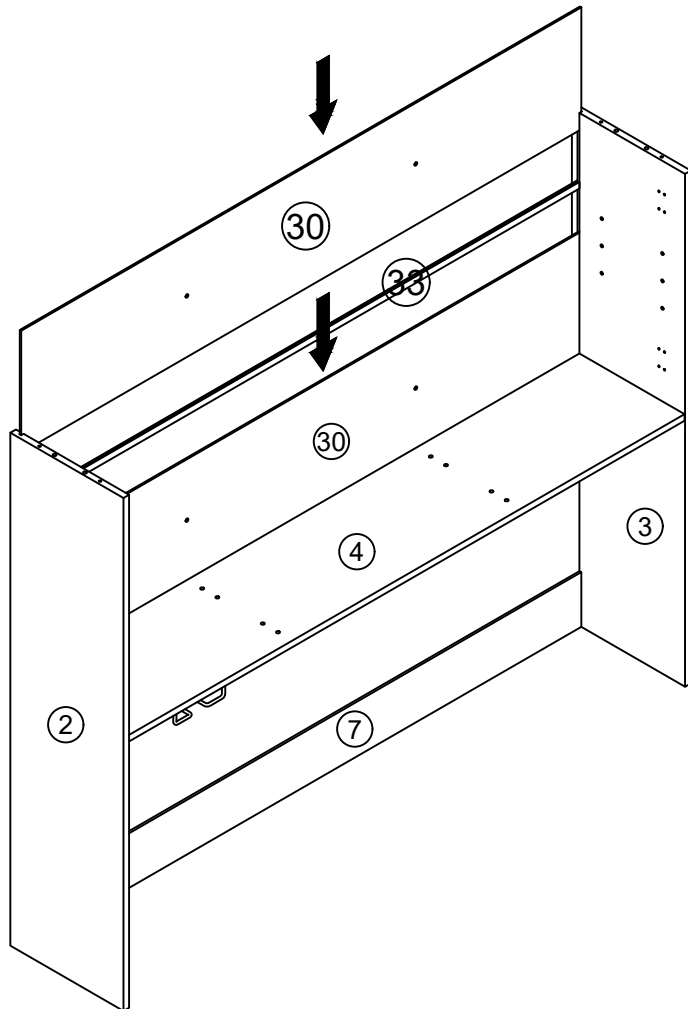
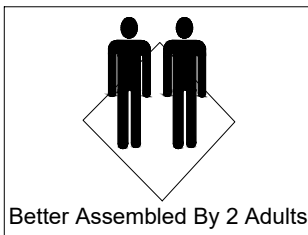

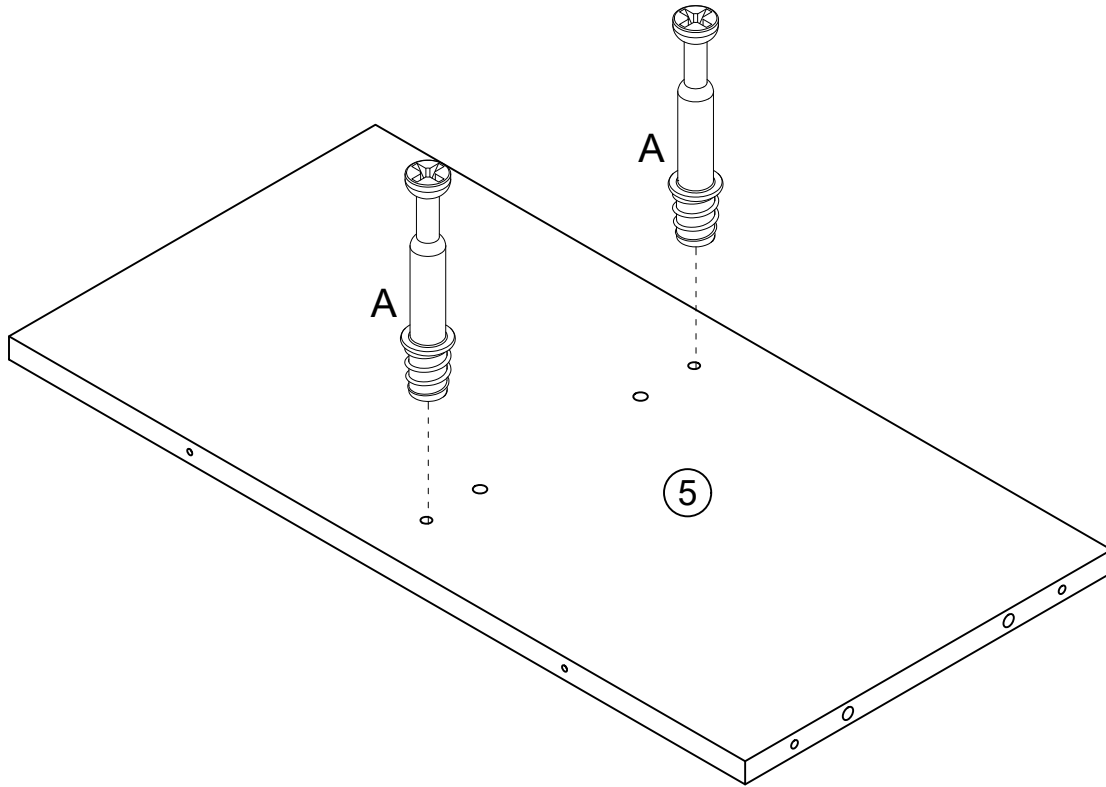

x2

A x 4

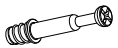

Ø6x35mm

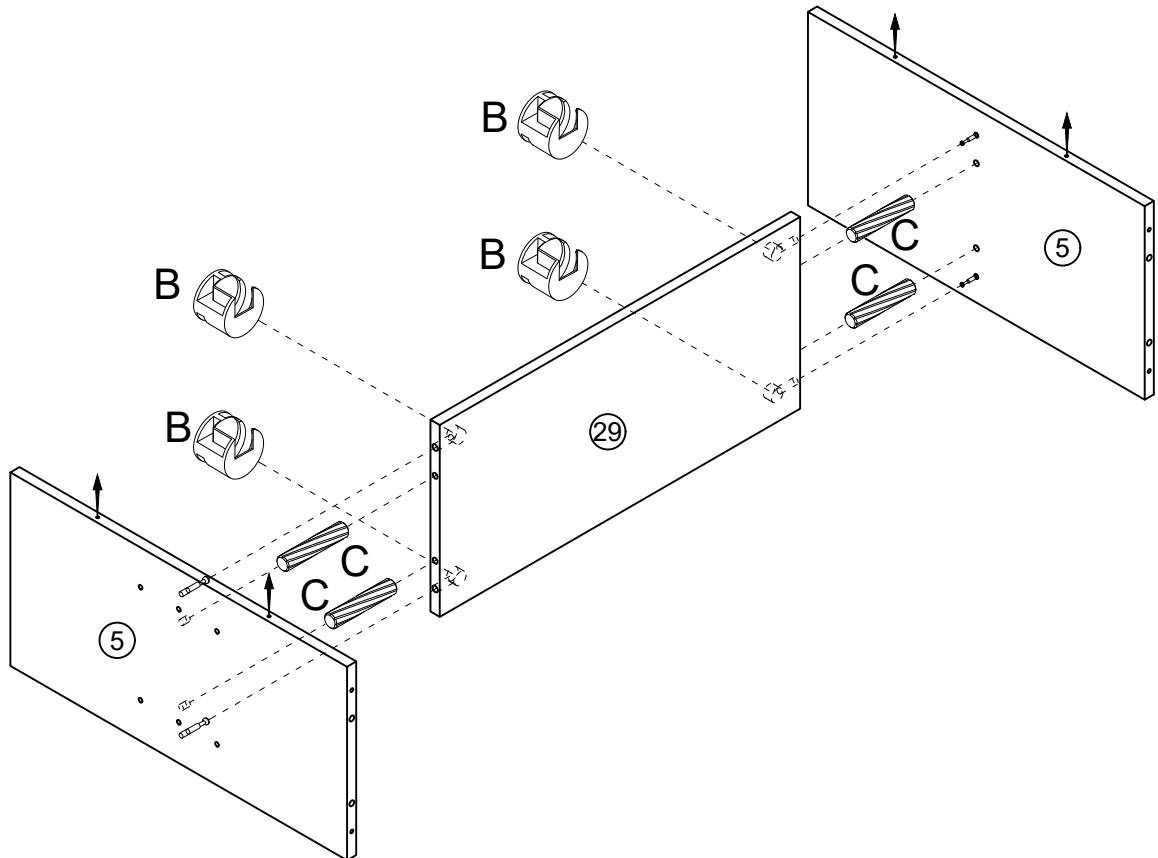

B x 4



Ø15x10mm

C x 4



Ø6x30mm

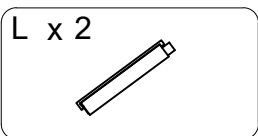
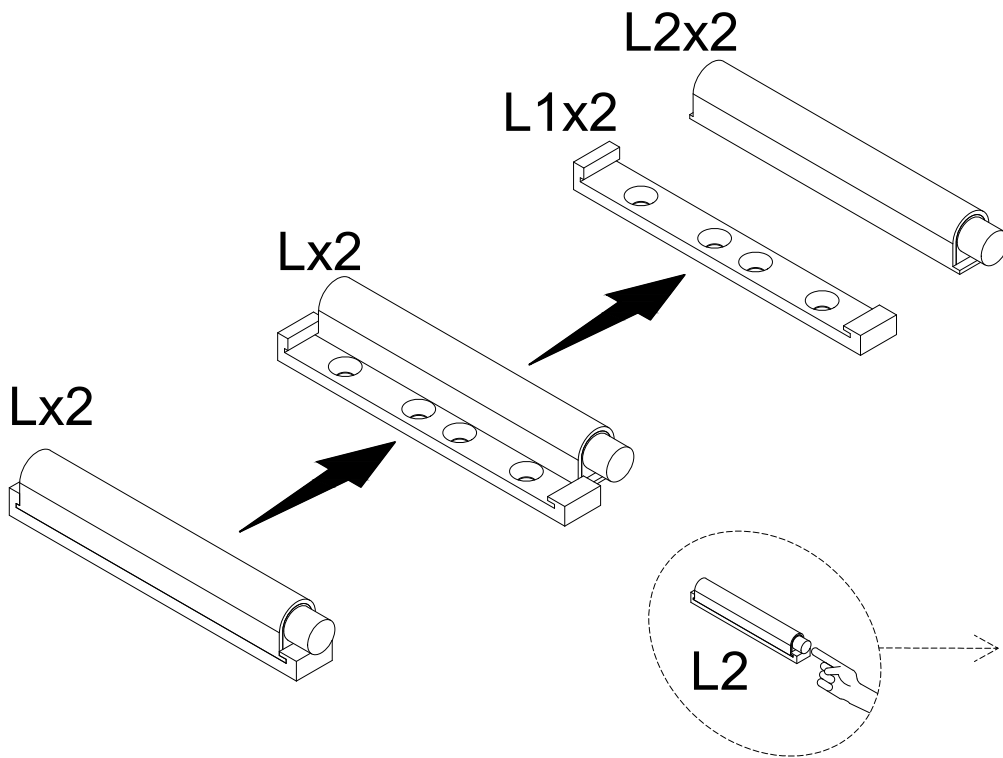
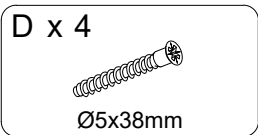
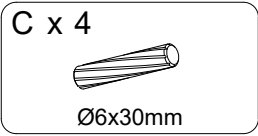
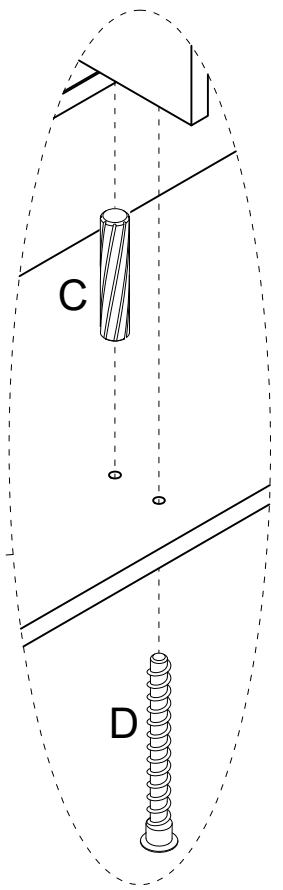
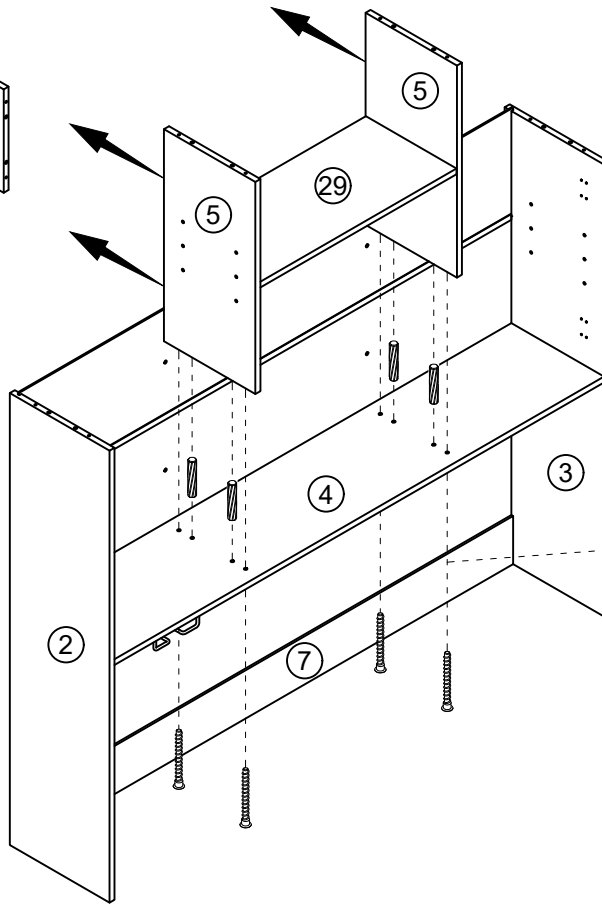
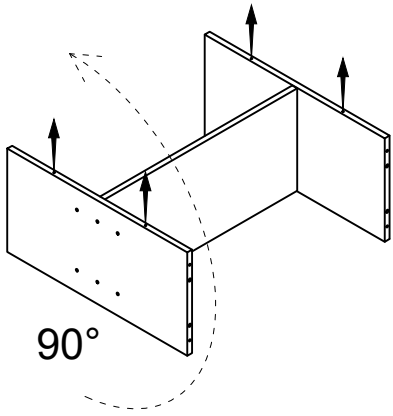

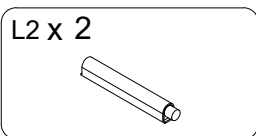
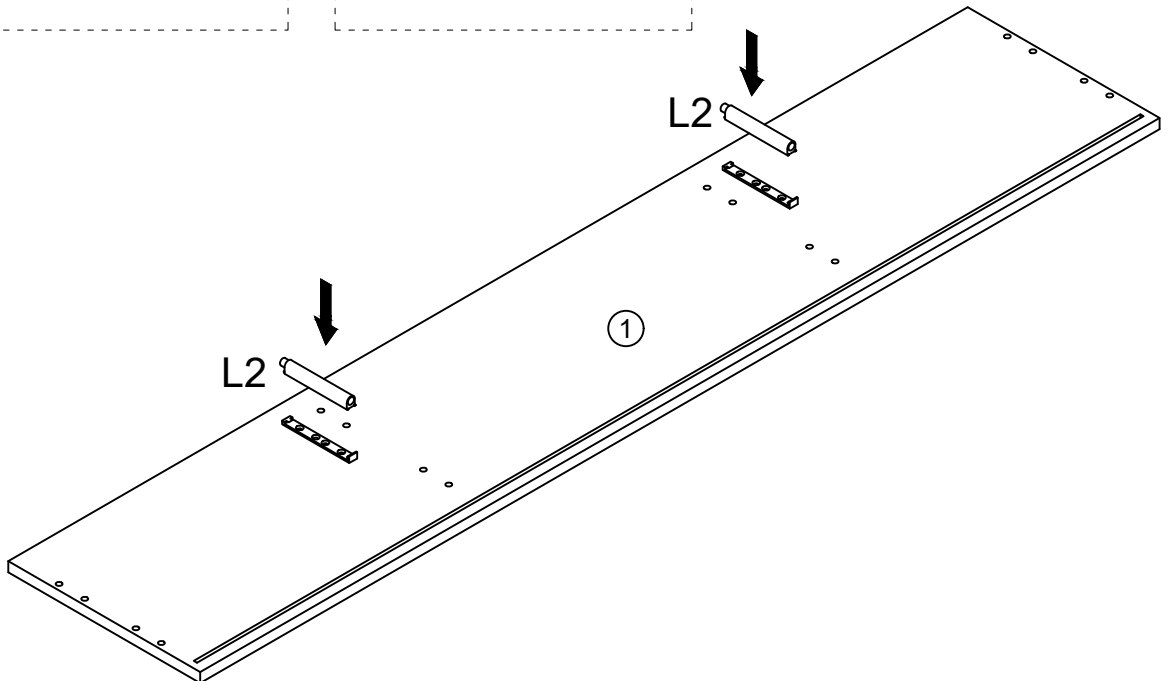
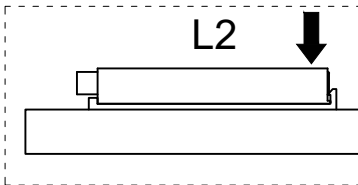
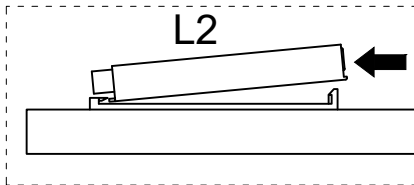
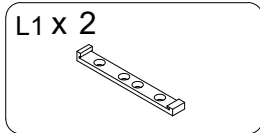
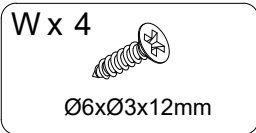
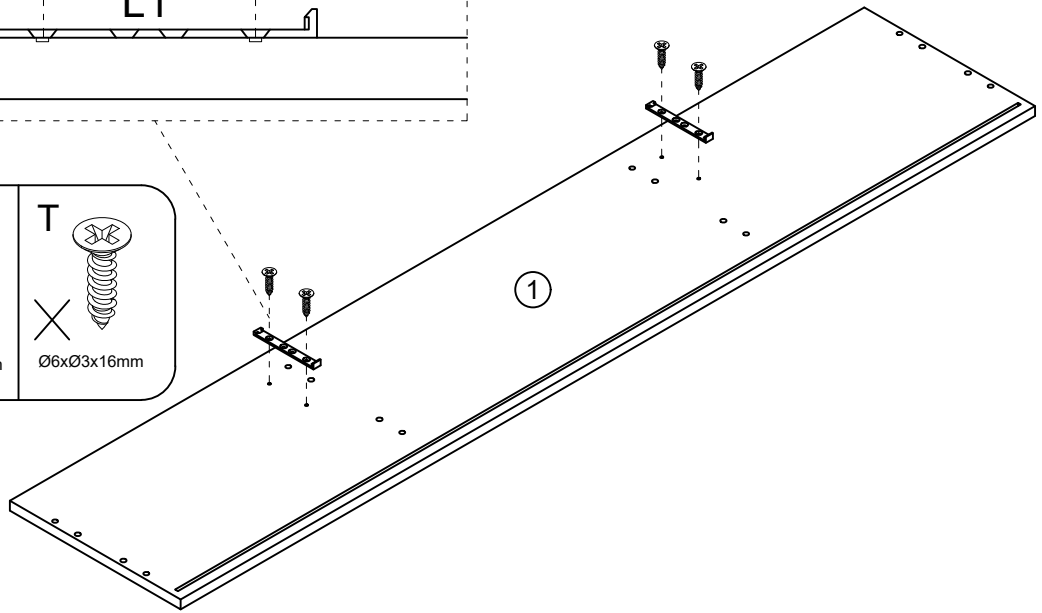
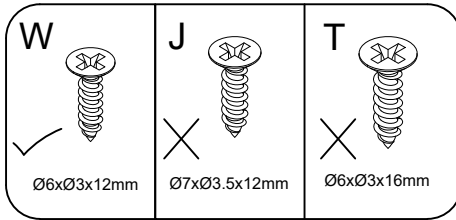
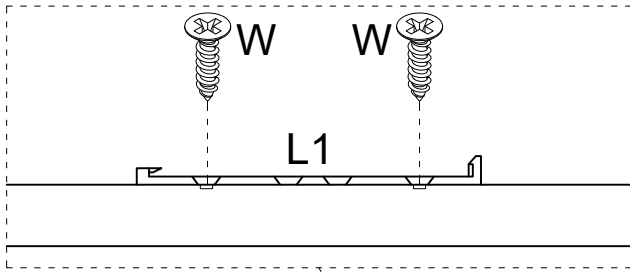

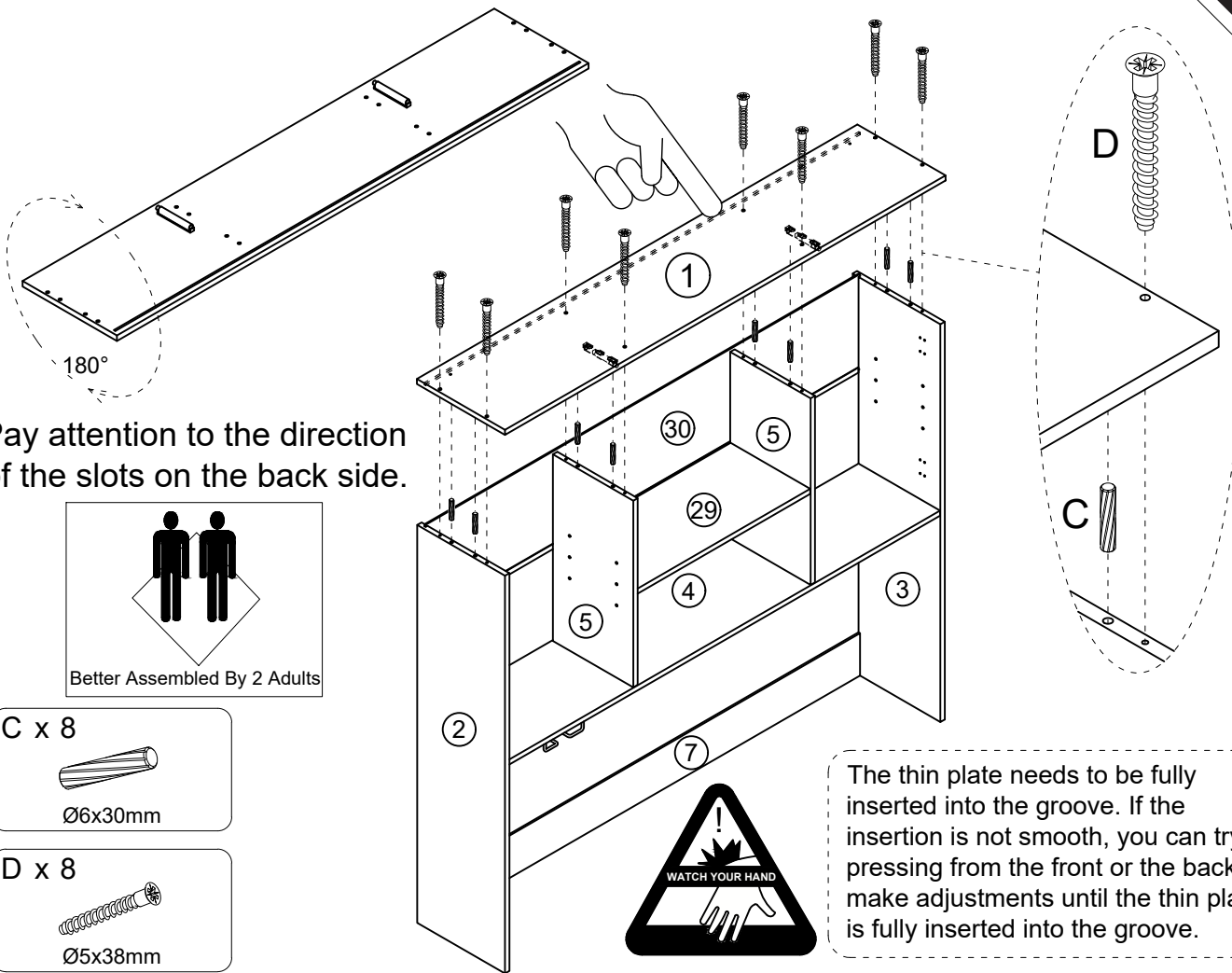

Pay attention to the direction of the slots on the back side.

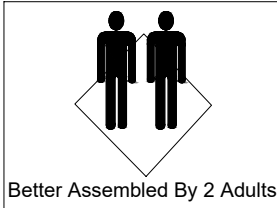

Better Assembled By 2 Adults

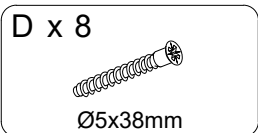
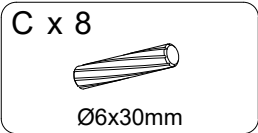

The thin plate needs to be fully inserted into the groove. If the insertion is not smooth, you can try pressing from the front or the back to make adjustments until the thin plate is fully inserted into the groove.

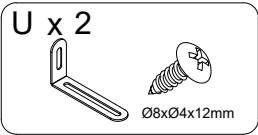
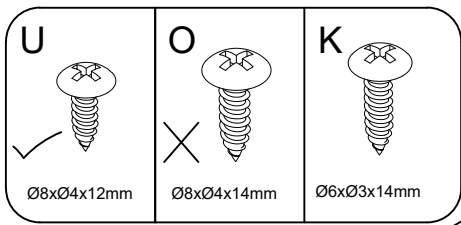
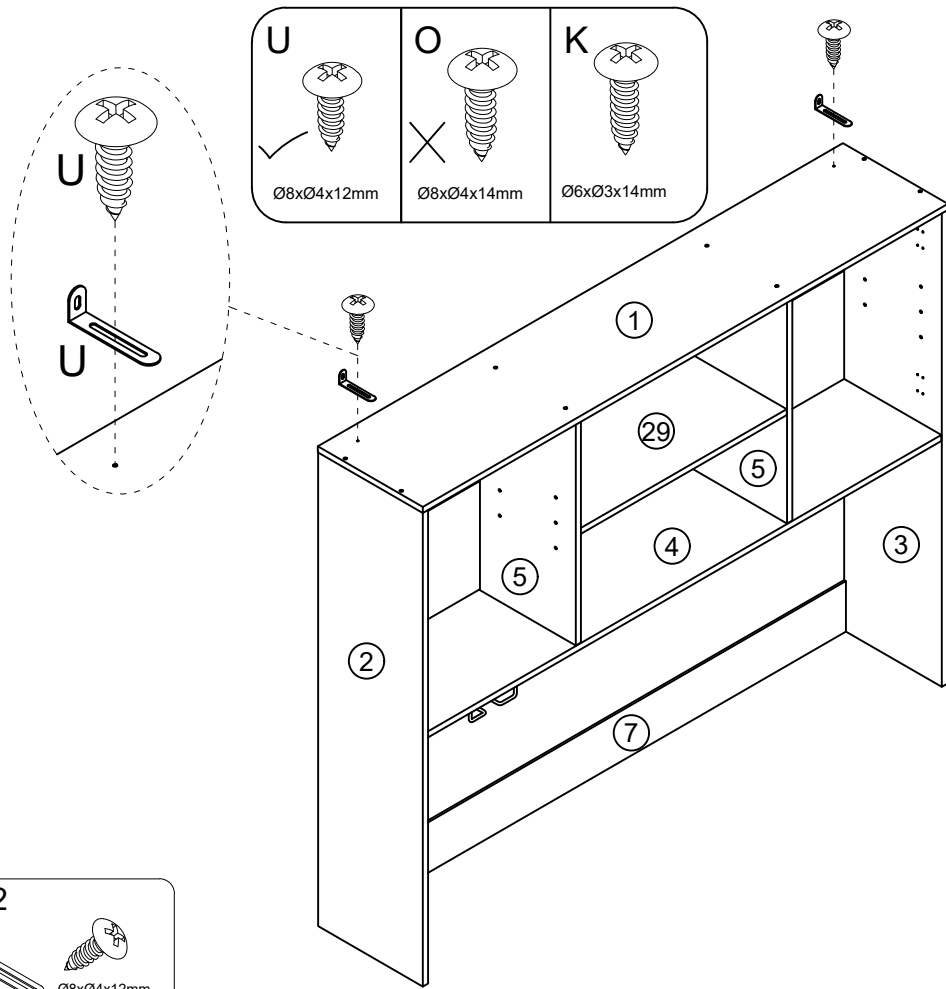

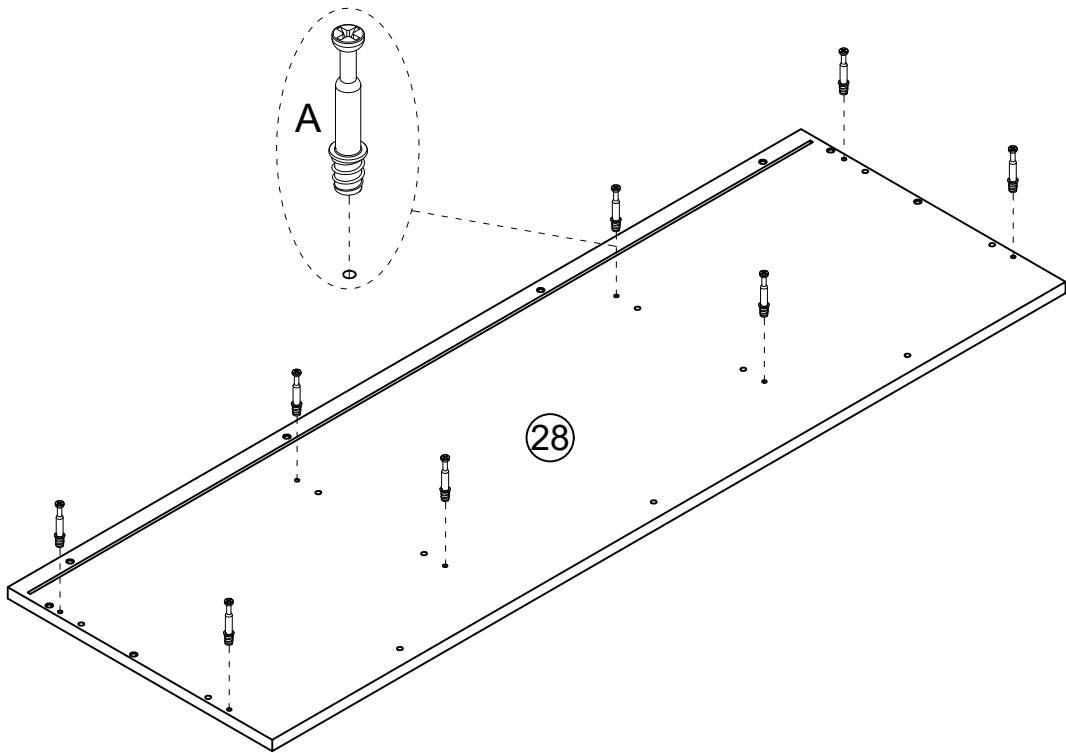

A x 8



Ø6x35mm

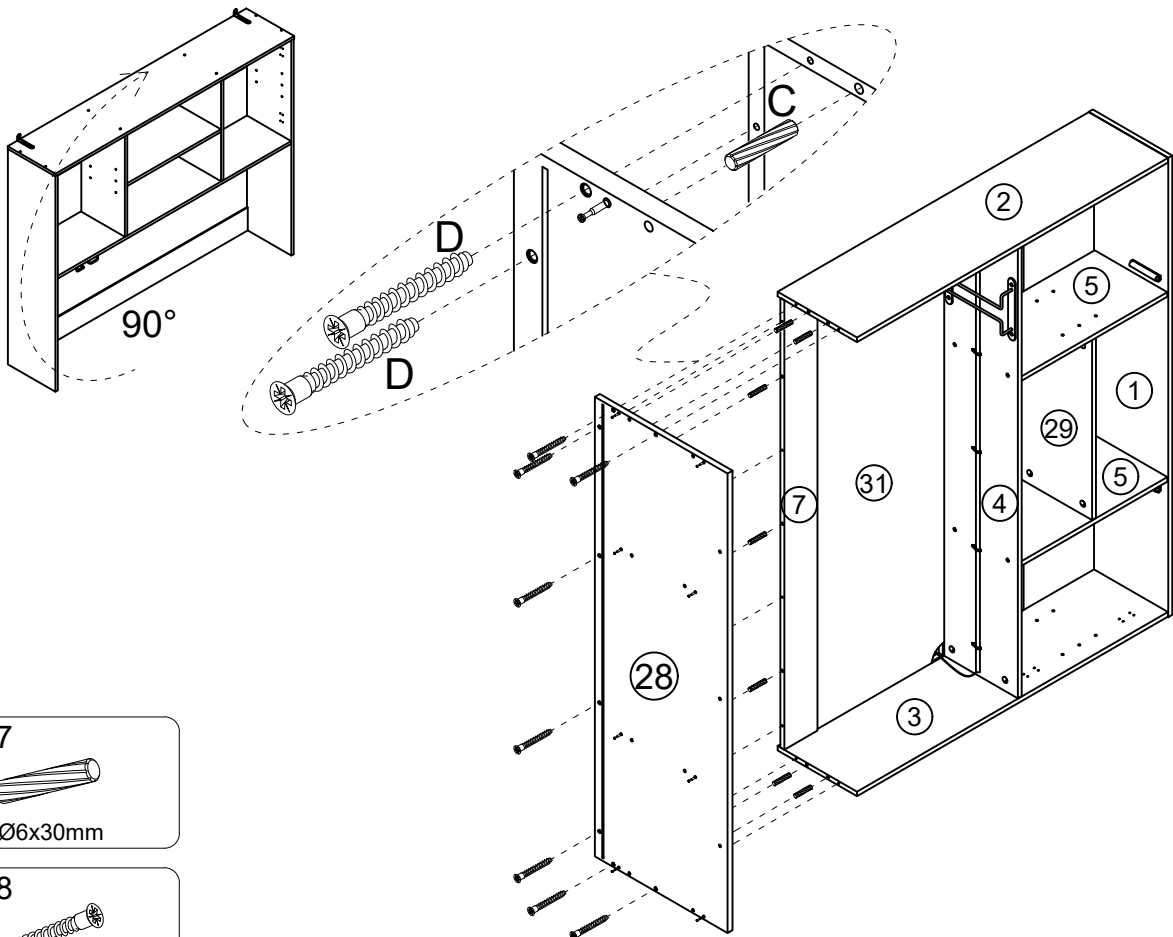

C x 7



Ø6x30mm

D x 8



Ø5x38mm

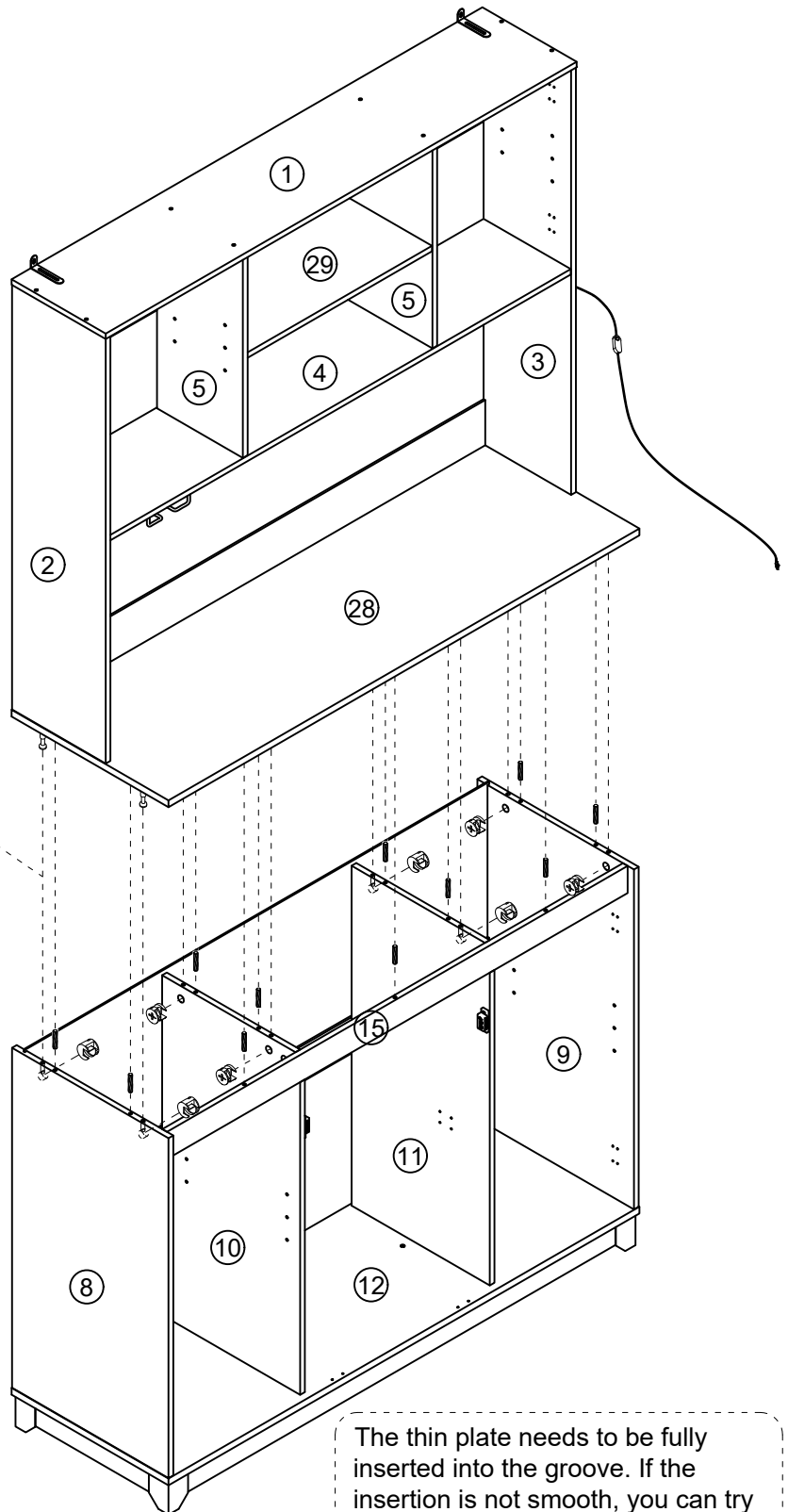
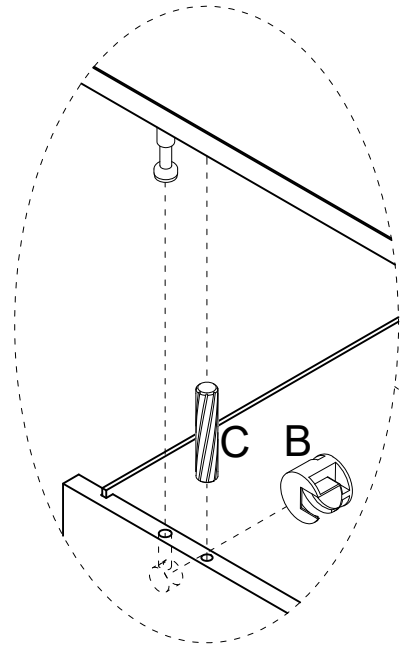
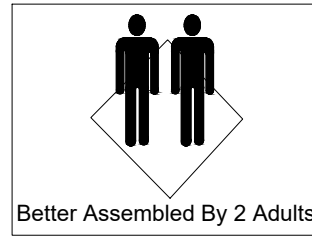
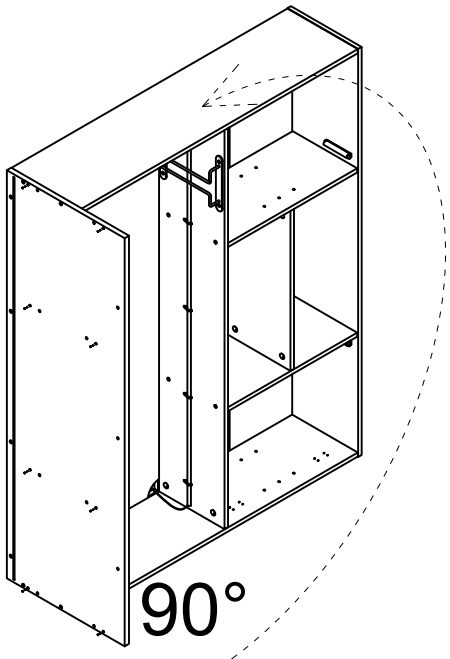

During this installation step, if the lighting is poor, you can use a flashlight.

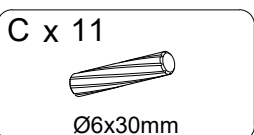

The thin plate needs to be fully inserted into the groove. If the insertion is not smooth, you can try pressing from the front or the back to make adjustments until the thin plate is fully inserted into the groove.

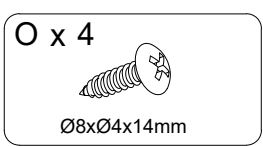
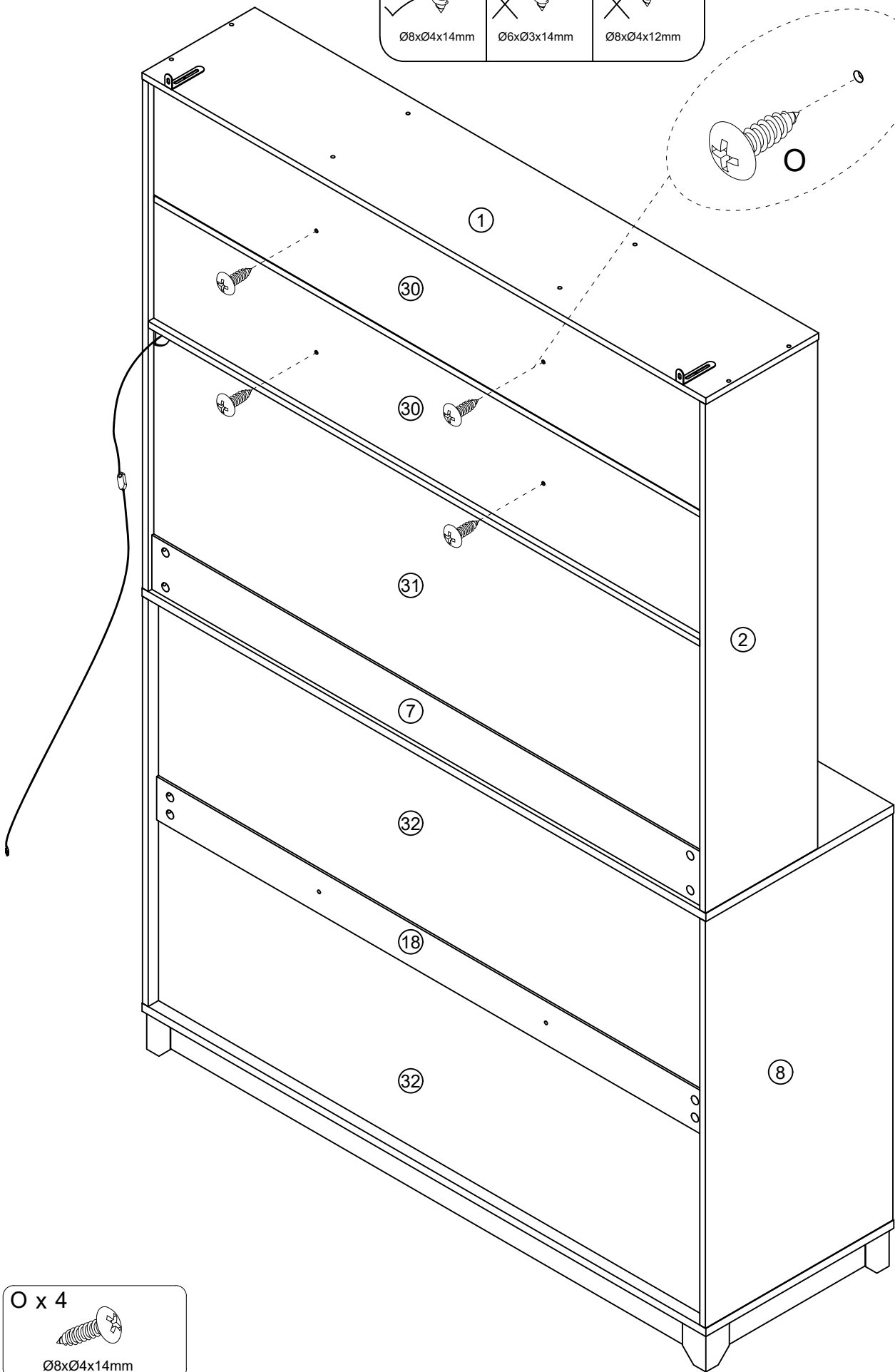
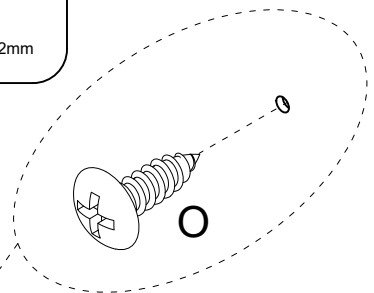
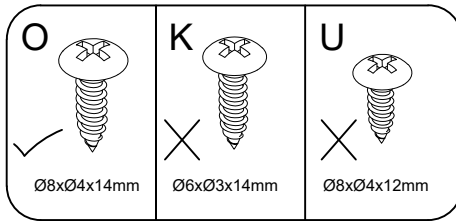

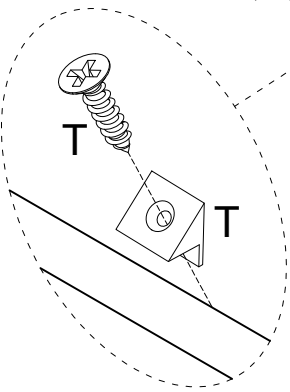
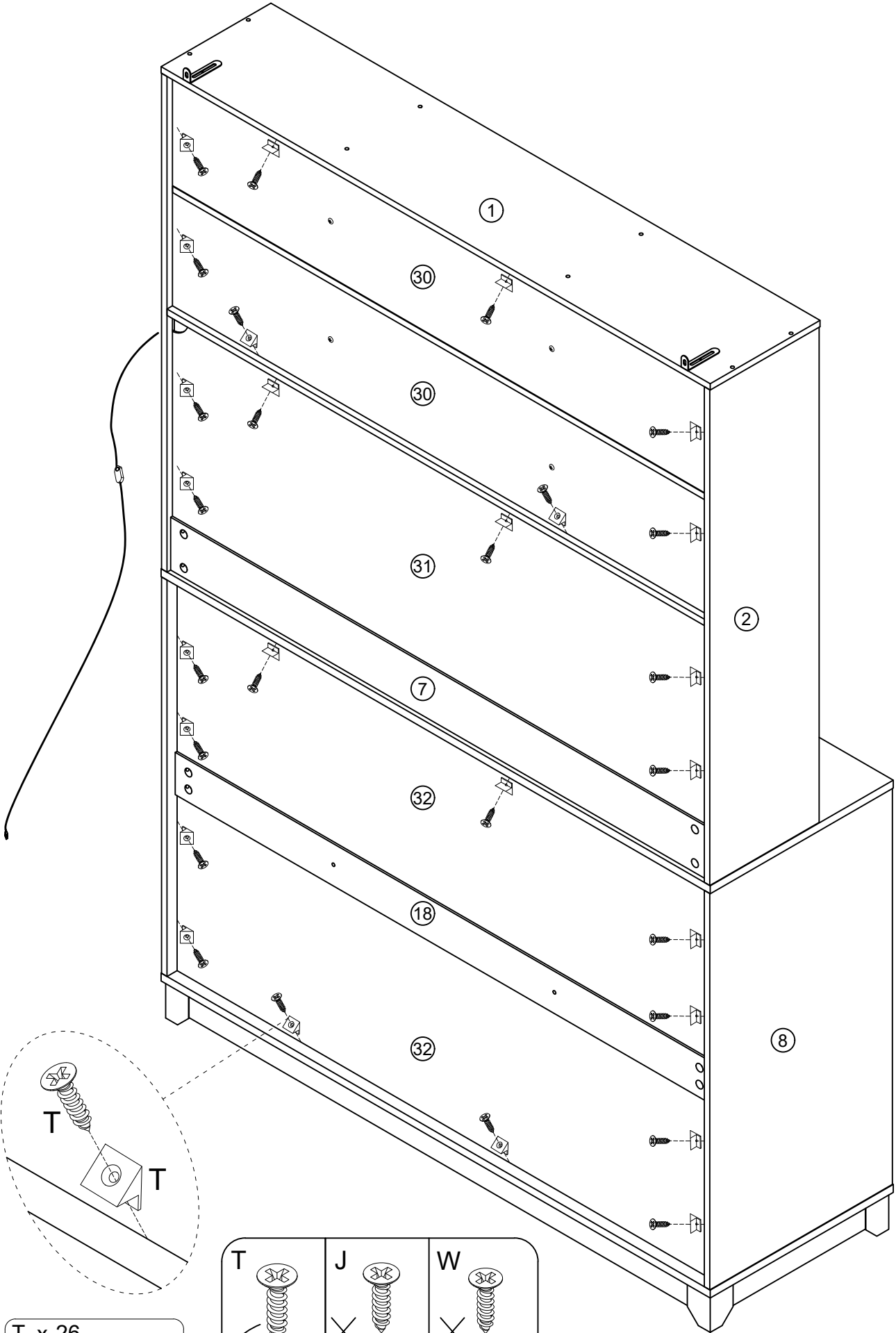

T x 26

Ø6xØ3x16mm

<p>T</p> <p>✓</p> <p>Ø6xØ3x16mm</p>	<p>J</p> <p>✗</p> <p>Ø7xØ3.5x12mm</p>	<p>W</p> <p>✗</p> <p>Ø6xØ3x12mm</p>
--	--	--

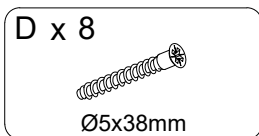
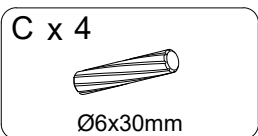
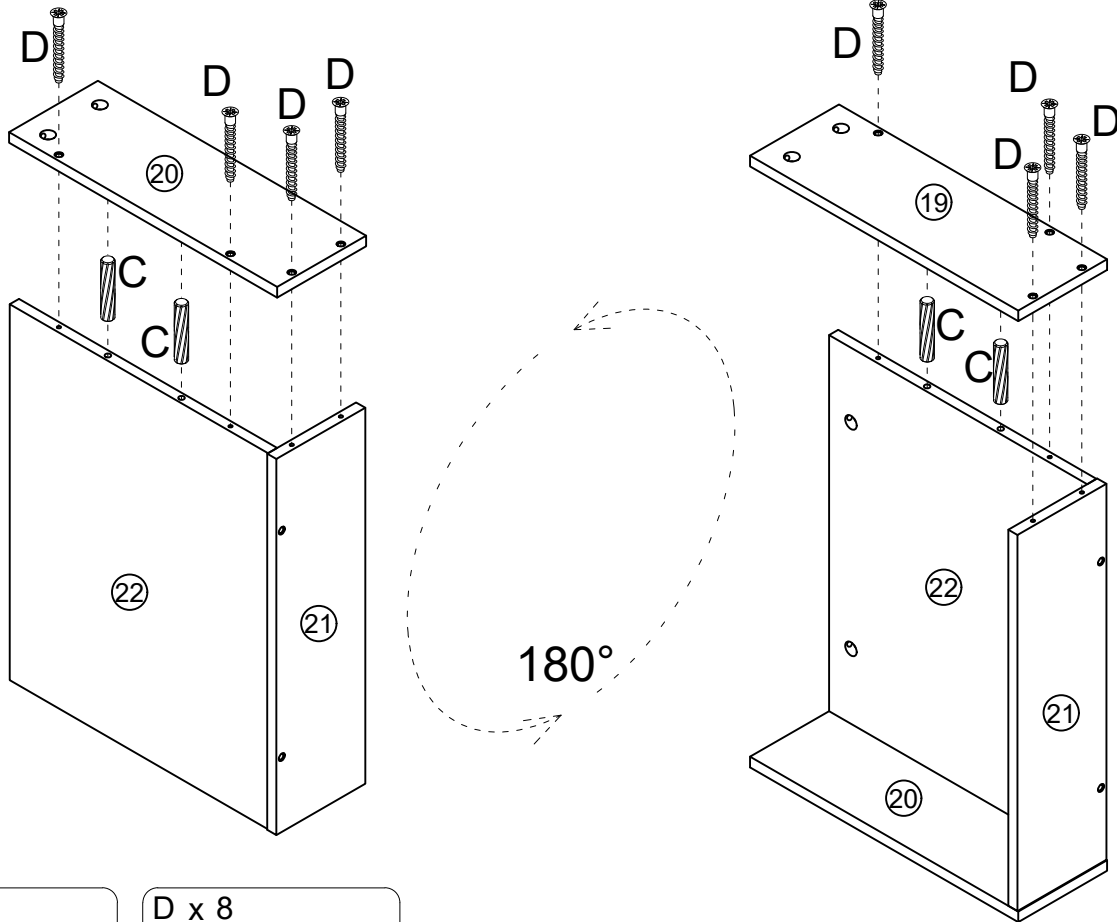
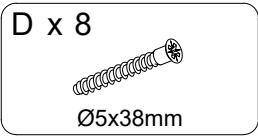
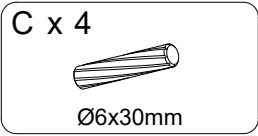
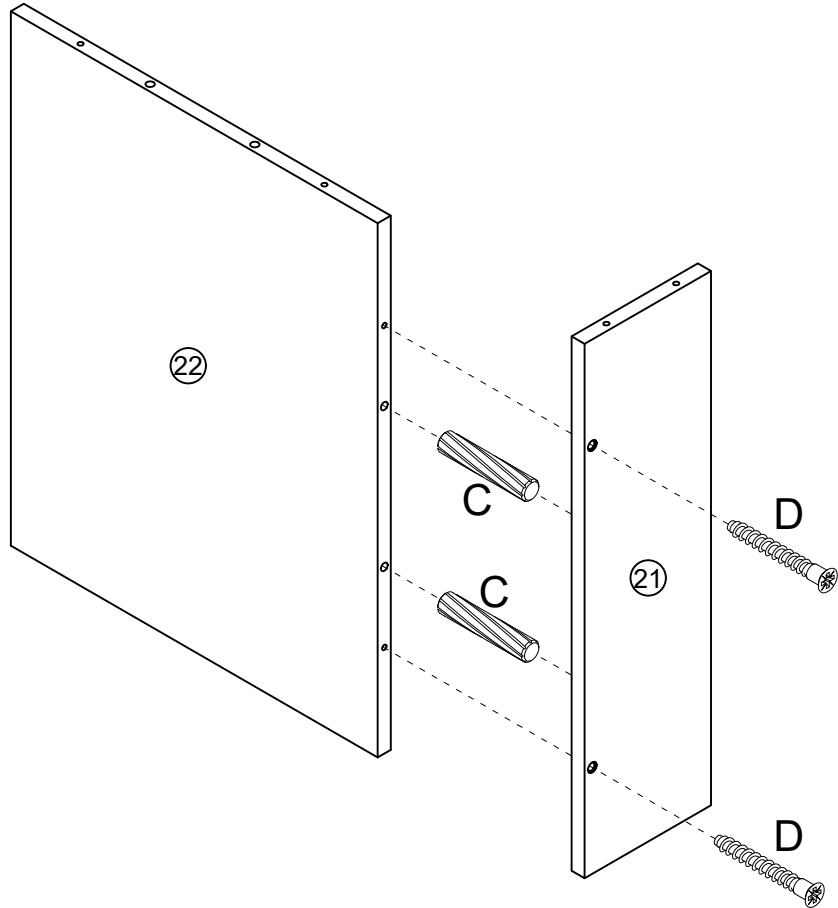

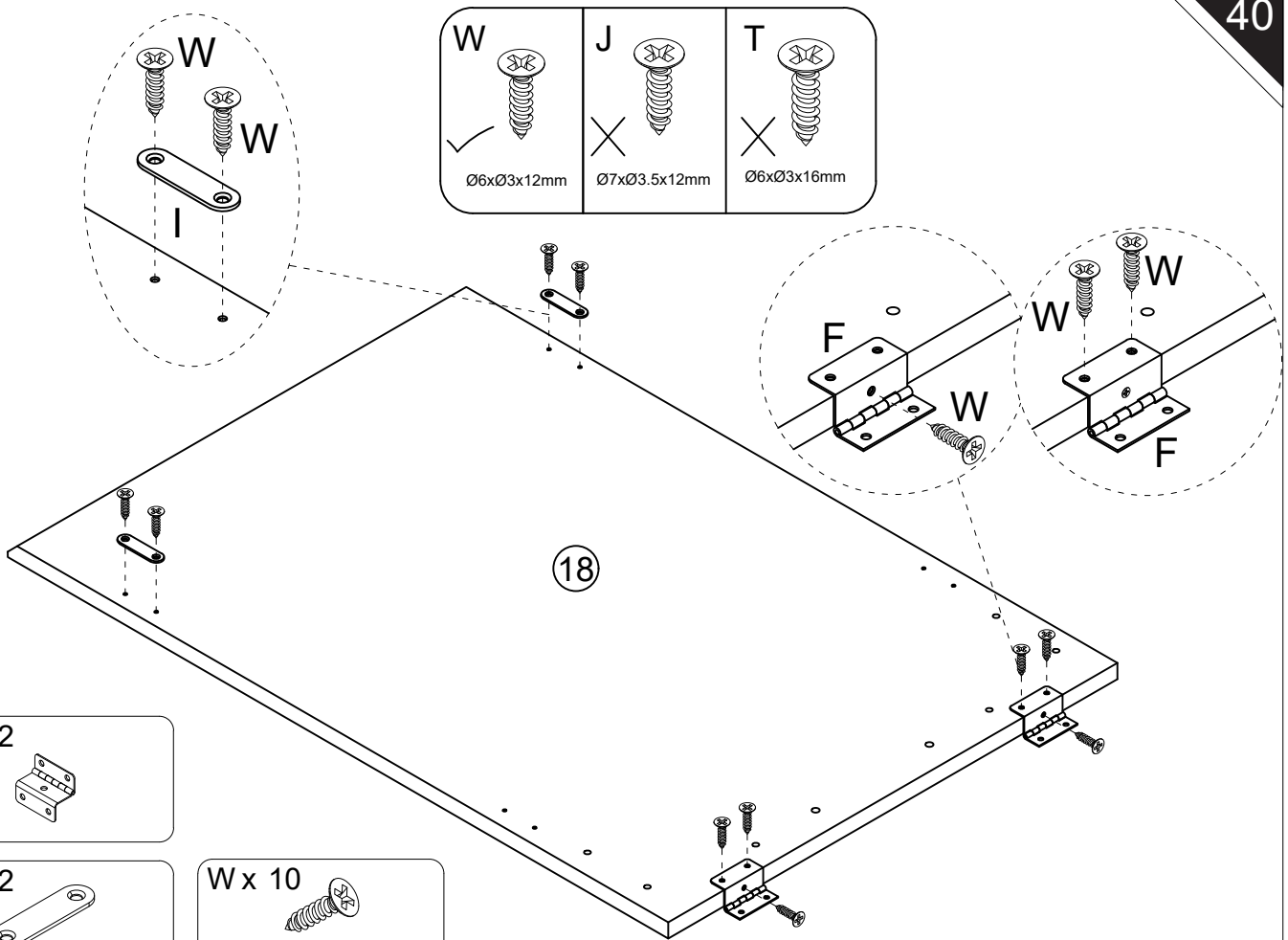

<p>W</p> <p>Ø6xØ3x12mm</p>	<p>J</p> <p>Ø7xØ3.5x12mm</p>	<p>T</p> <p>Ø6xØ3x16mm</p>
-----------------------------------	-------------------------------------	-----------------------------------

F x 2

I x 2

45x12x1.3mm

W x 10

Ø6xØ3x12mm

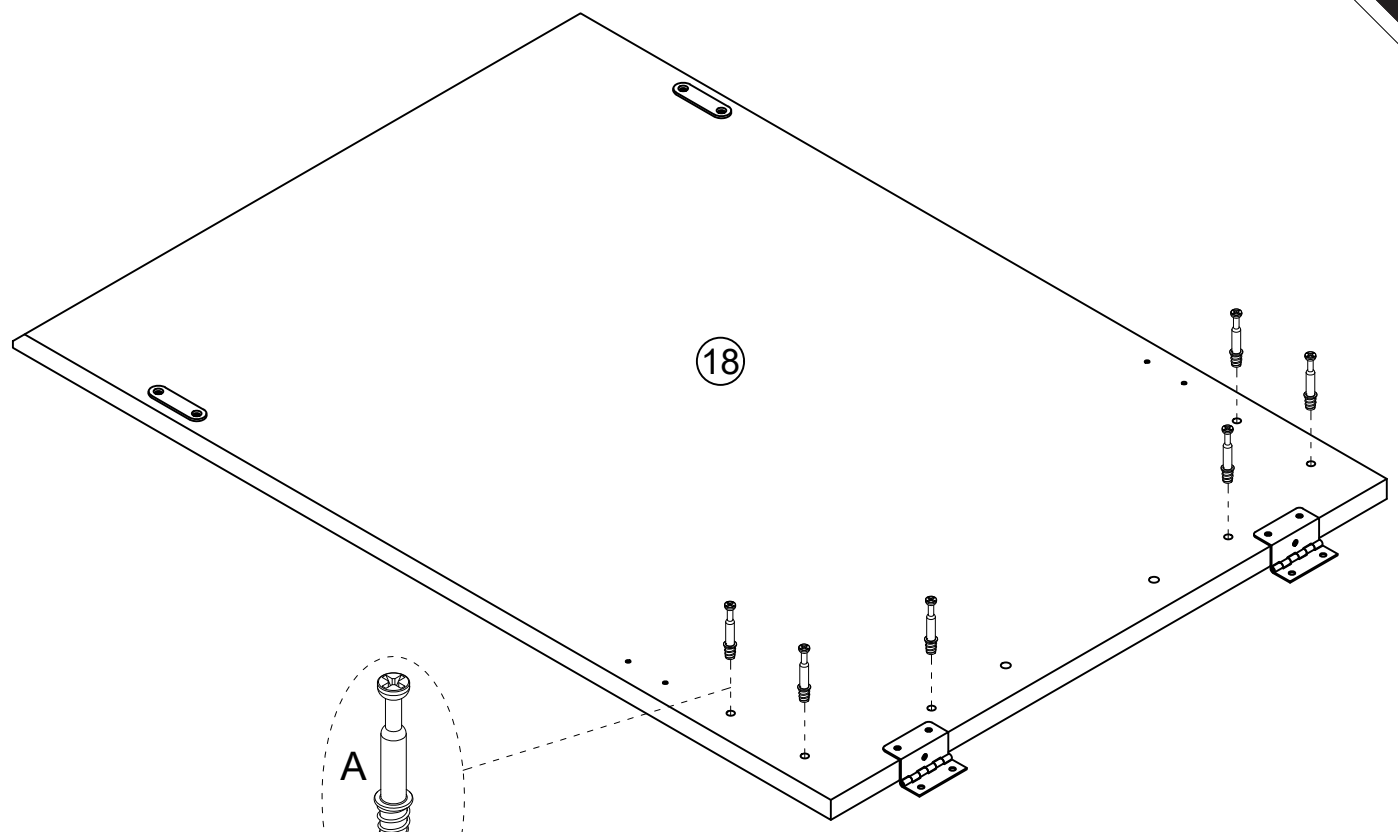



A x 6

Ø6x35mm

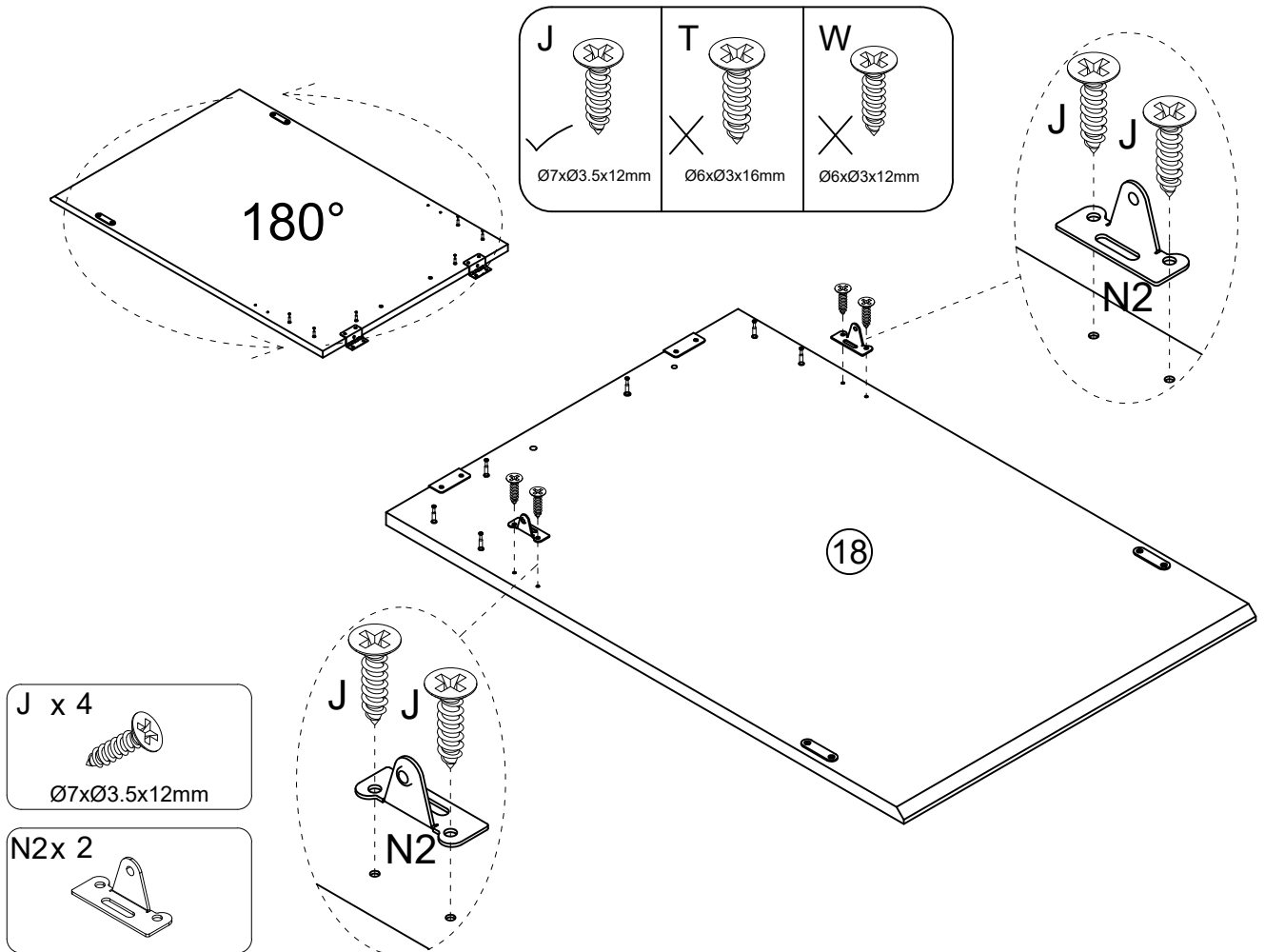
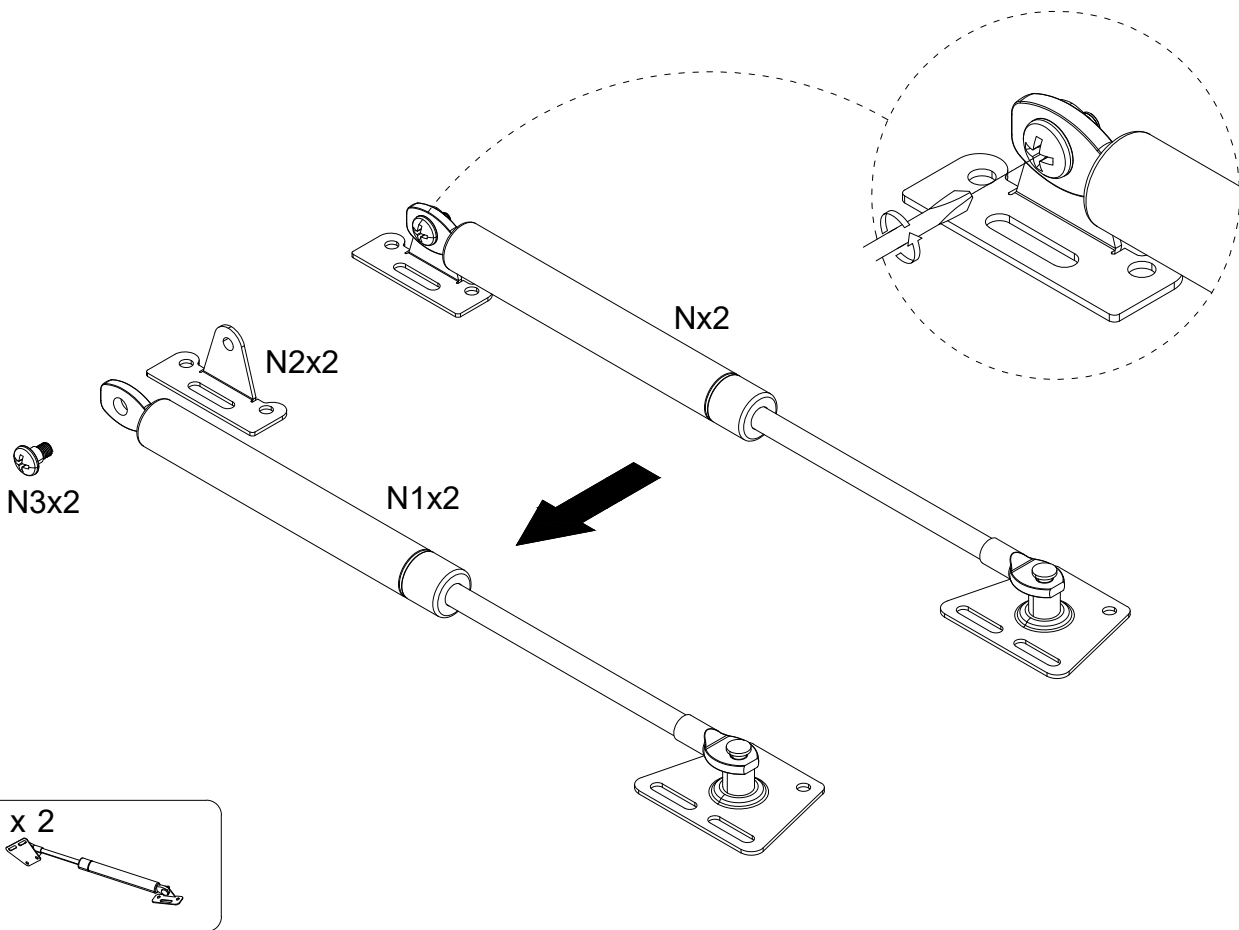
A

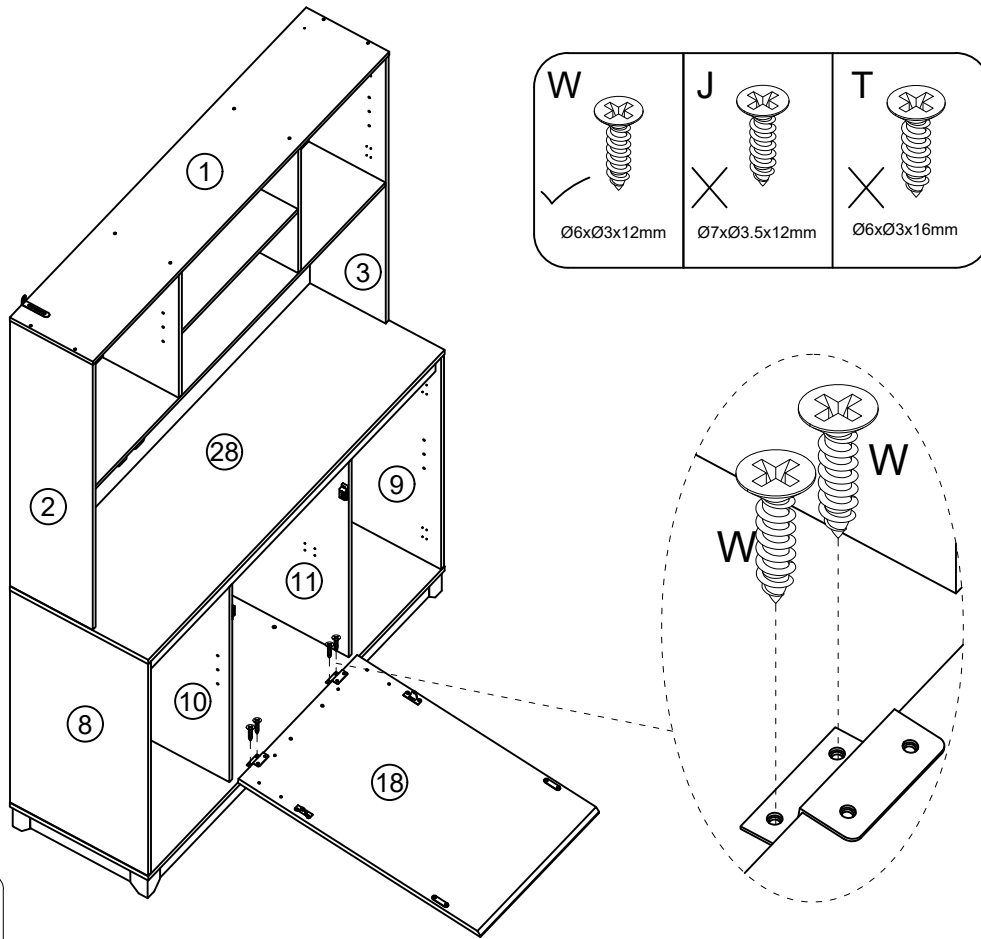

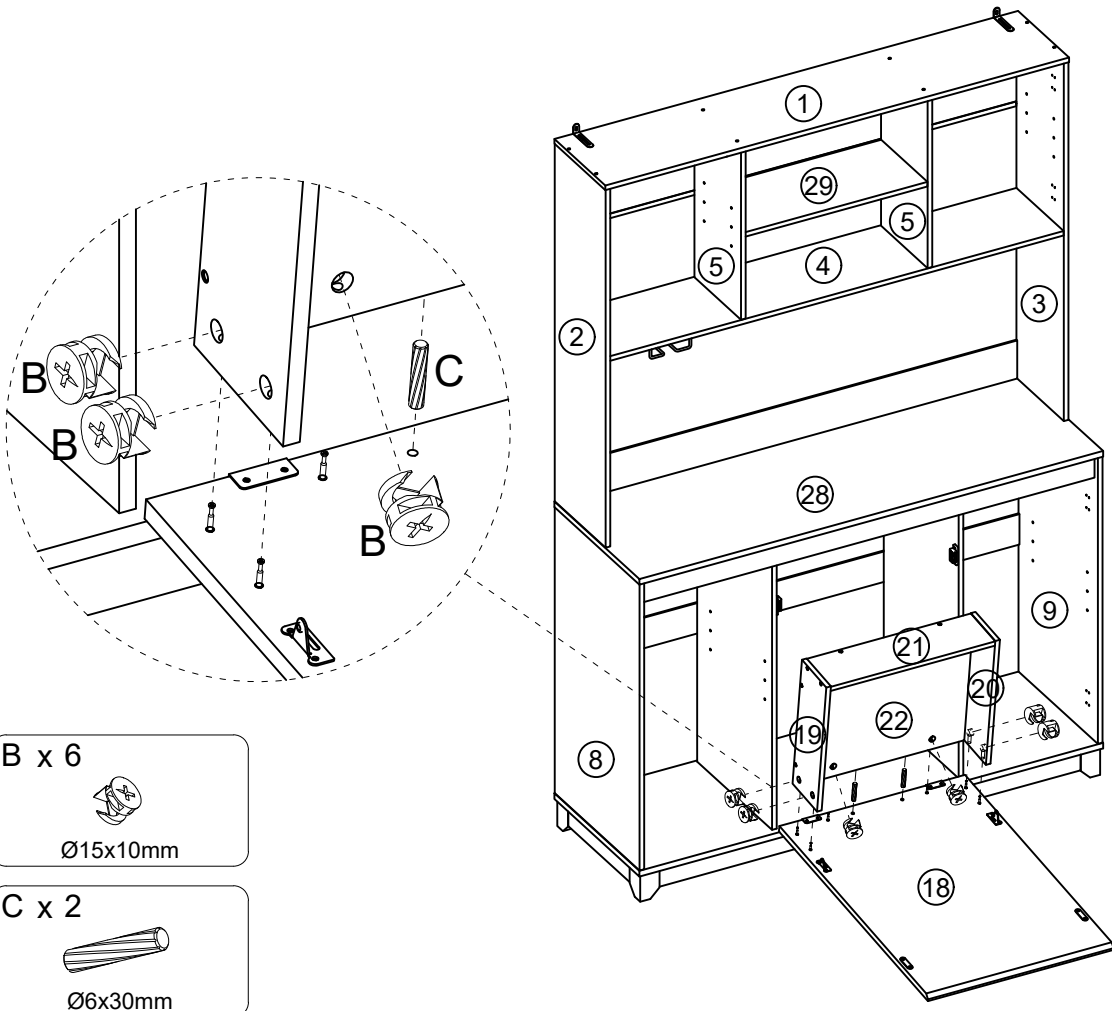

W x 4

 Ø6xØ3x12mm

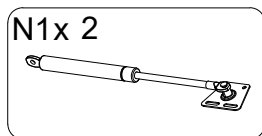
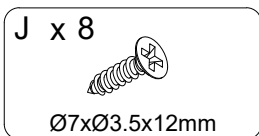
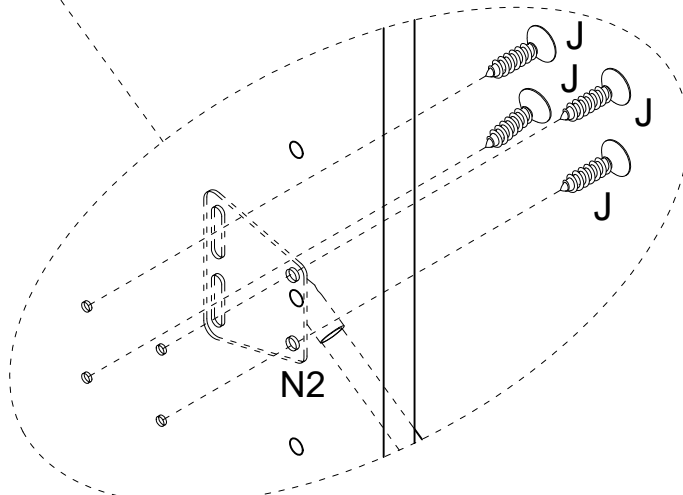
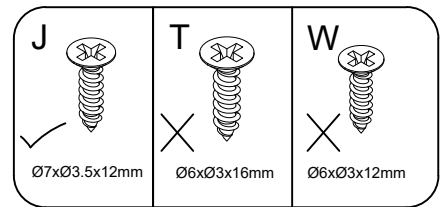
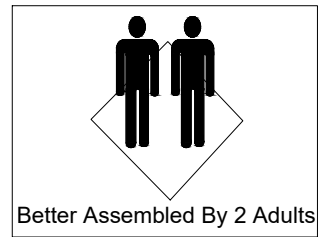
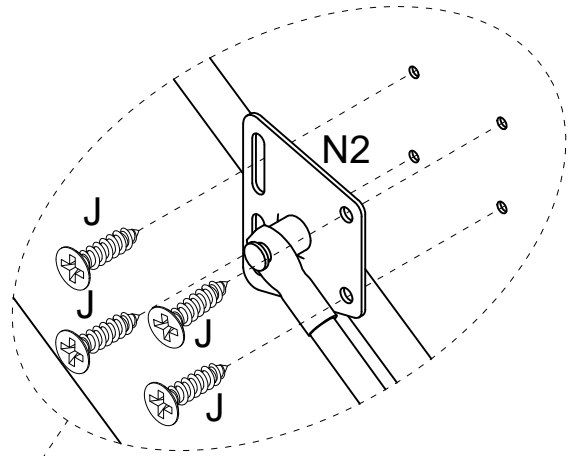
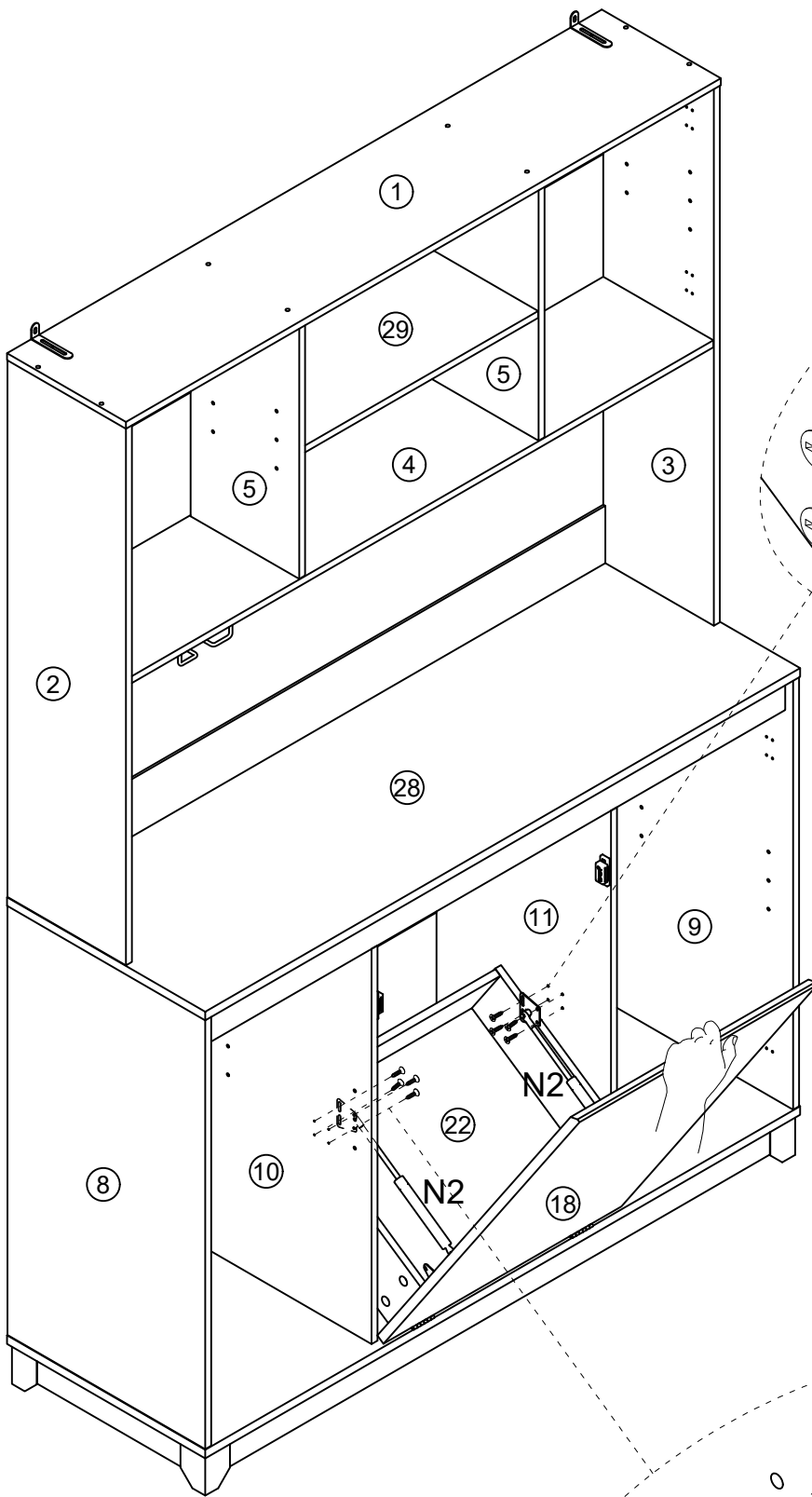

B x 6

 Ø15x10mm

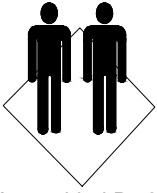
C x 2

 Ø6x30mm



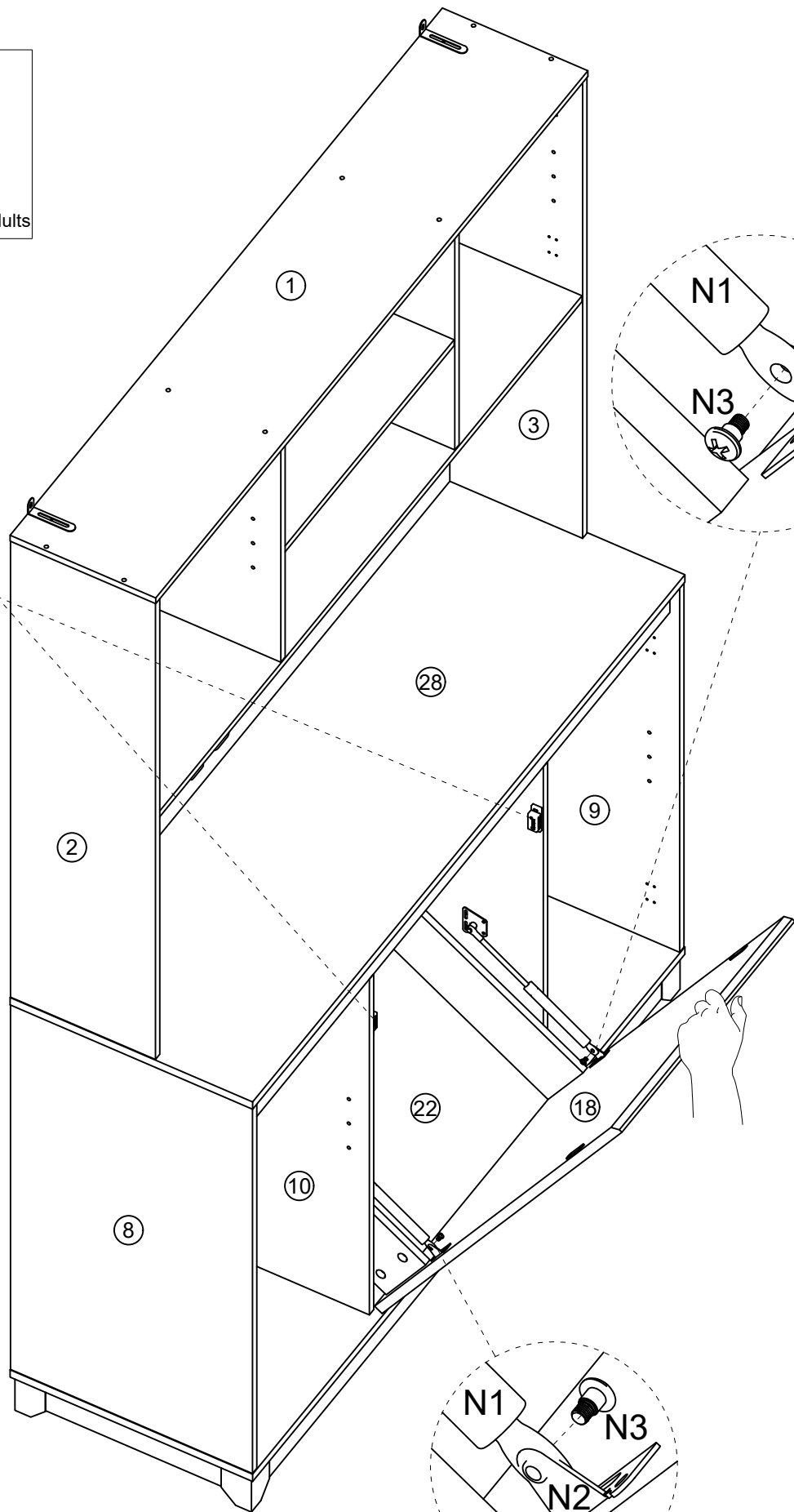
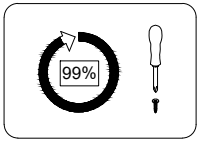

Better Assembled By 2 Adults

Mounting door panel
 Then adjust the position
 of the suction door
 The door is flat
 Before, the last lock
 The screws on the door
 Suck **K** to 99%



N3x 2



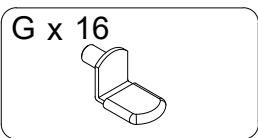
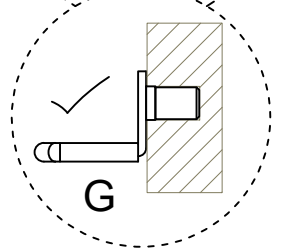
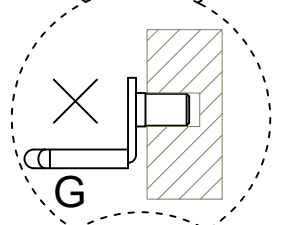
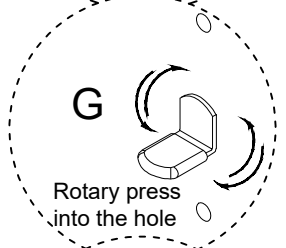
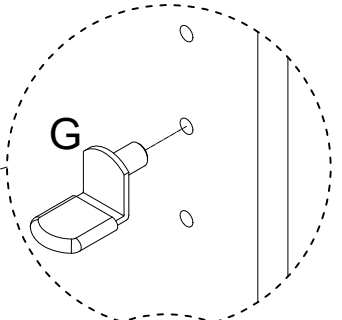
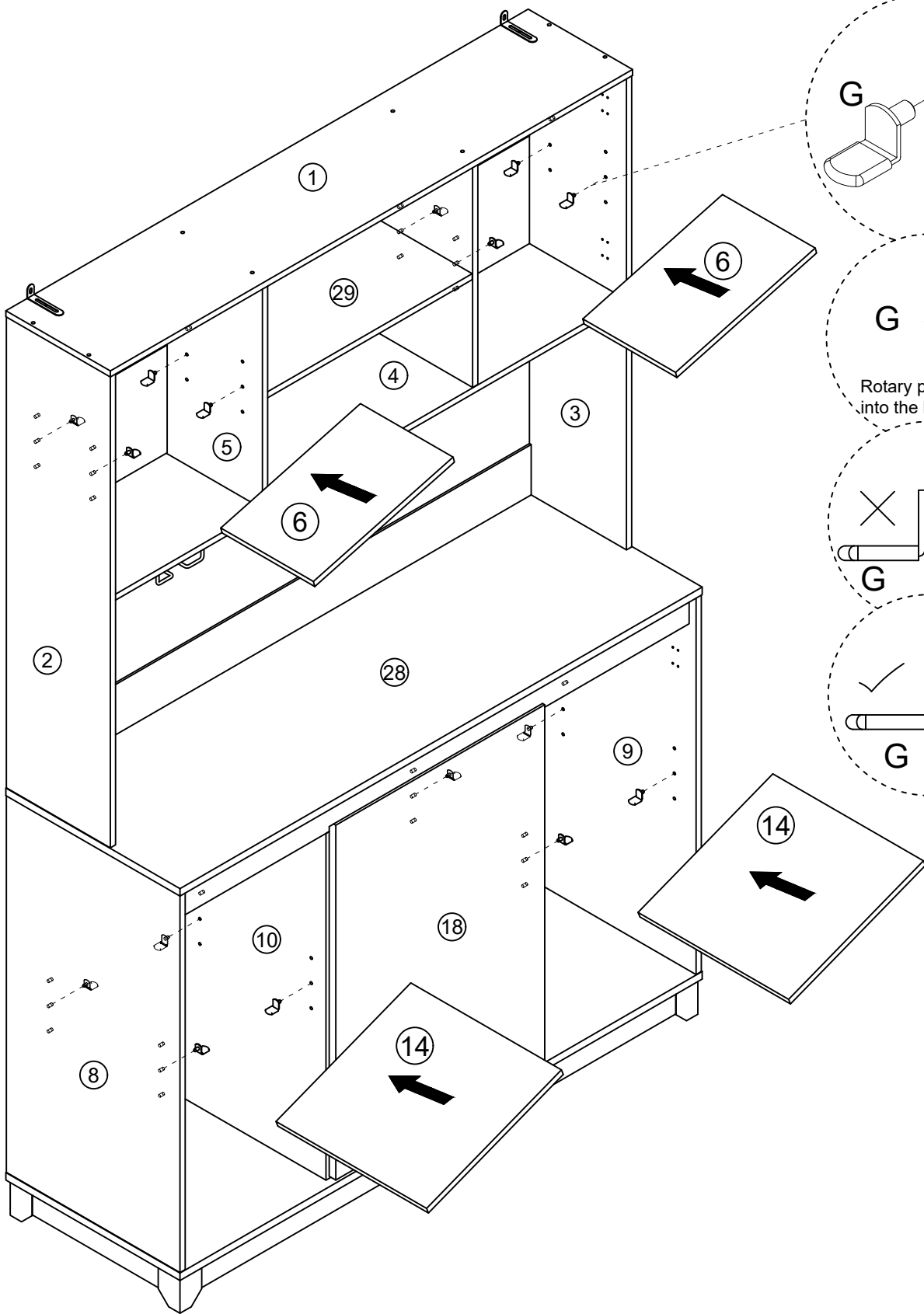

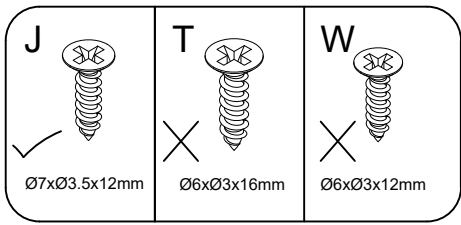

x2

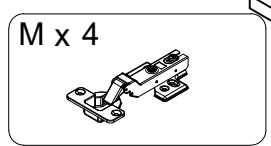
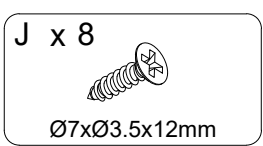
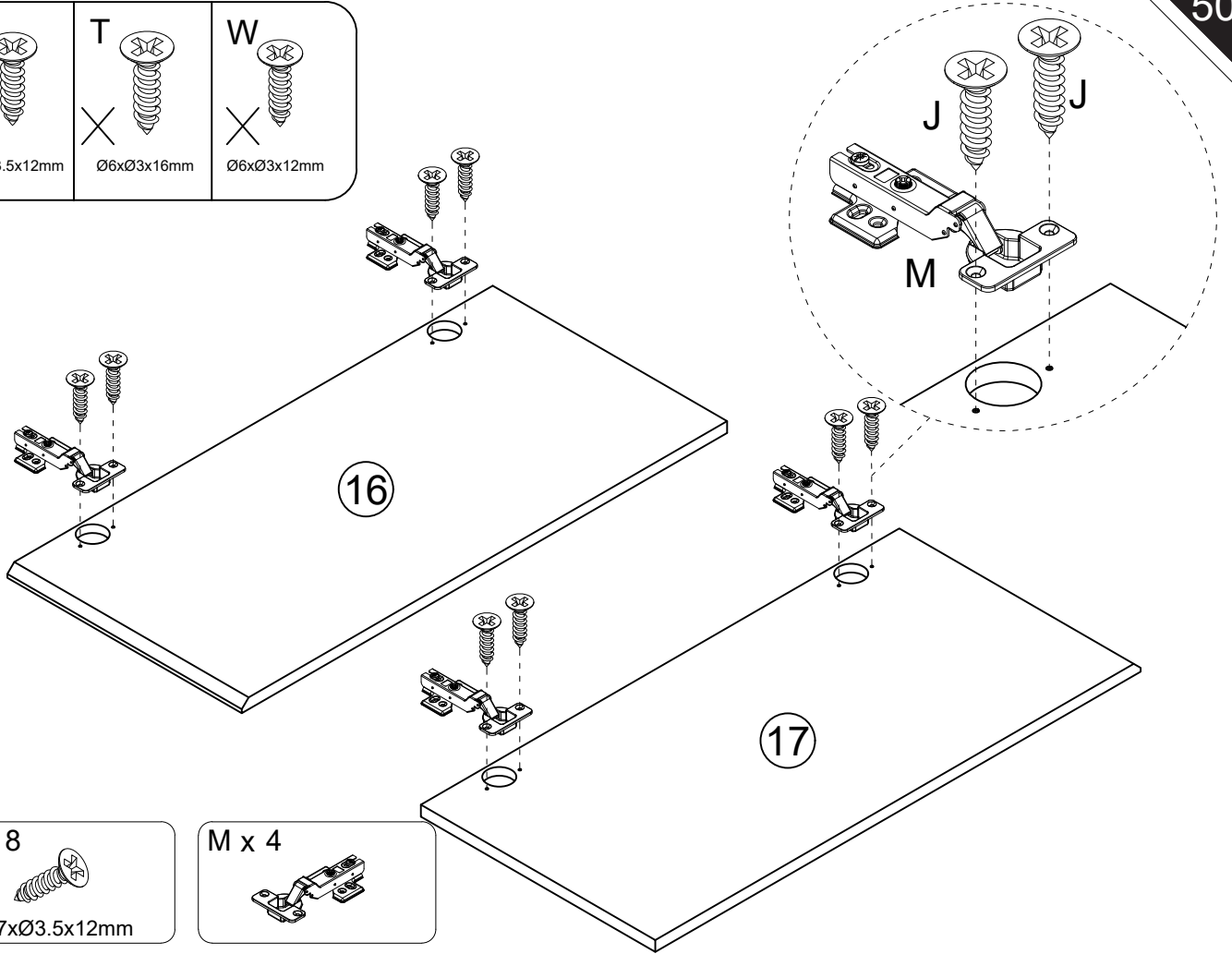
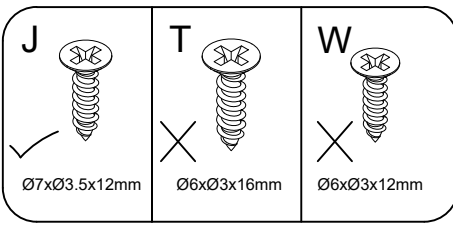
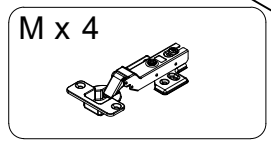
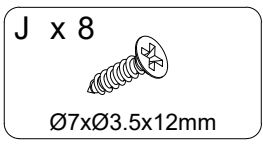
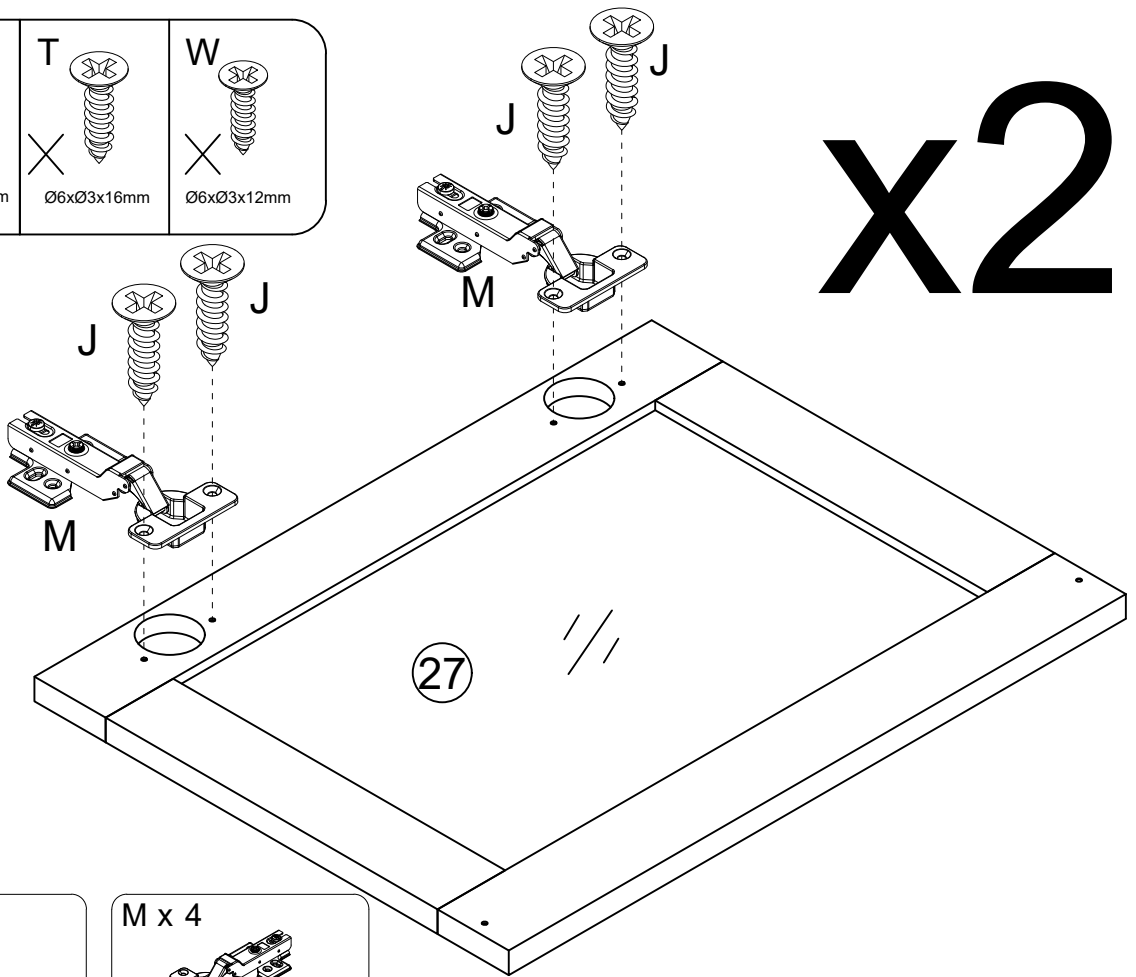

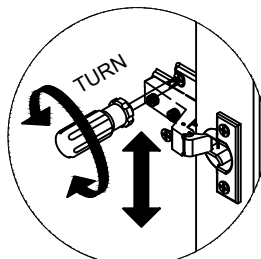
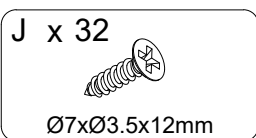
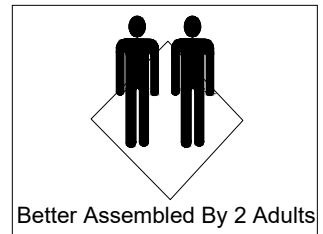
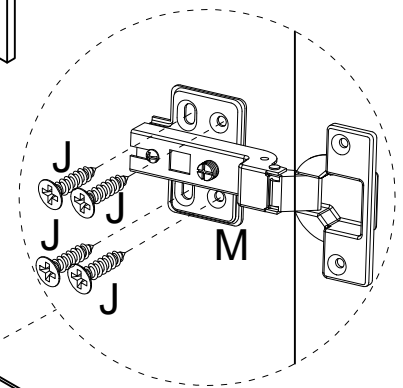
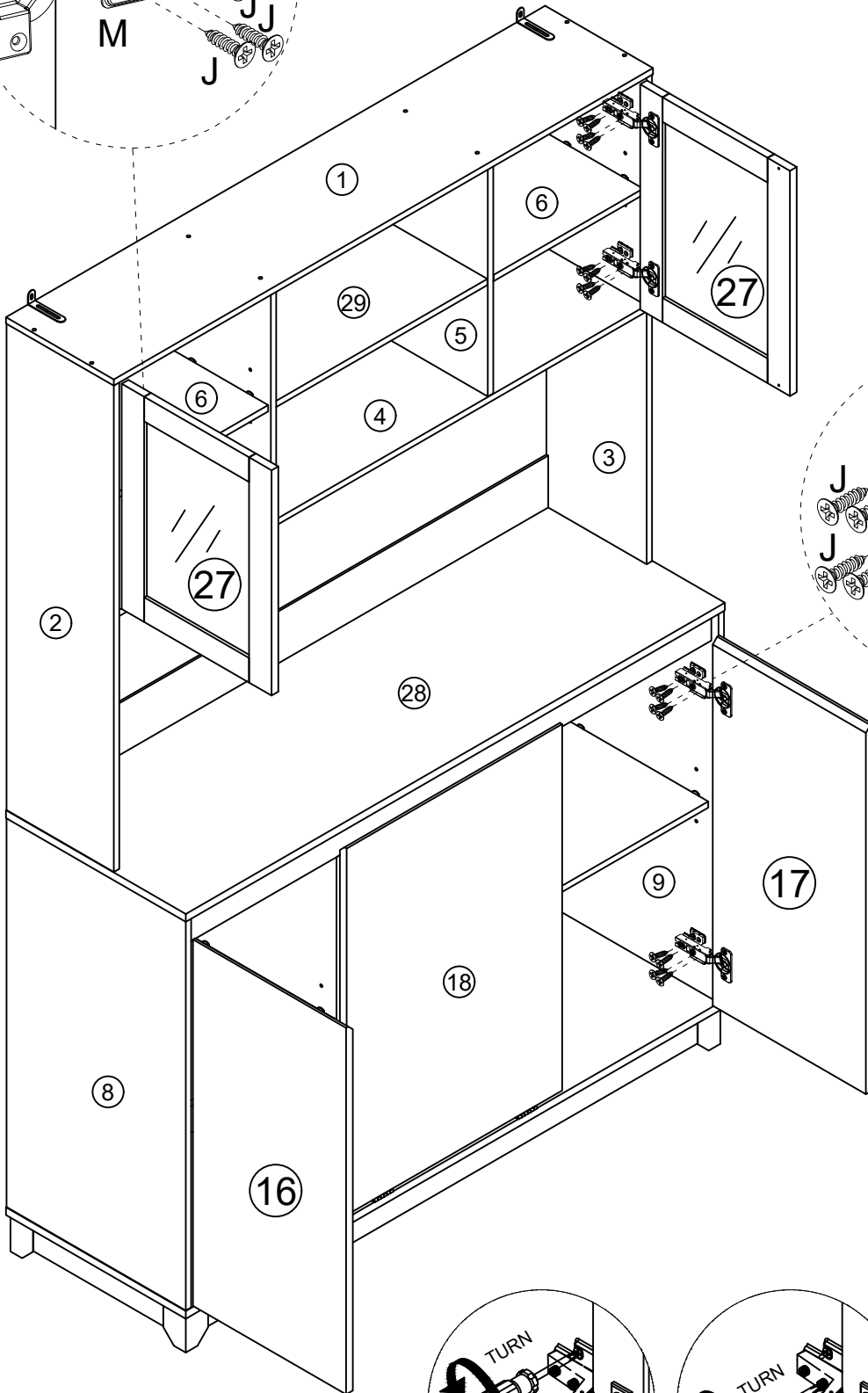
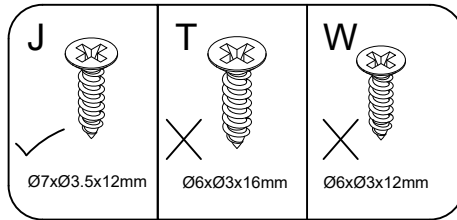
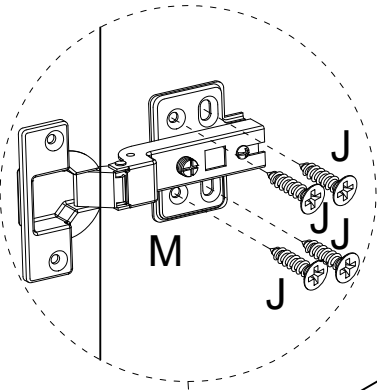

Loosen this screw and push up/down for a slight up-down adjustment of the door.

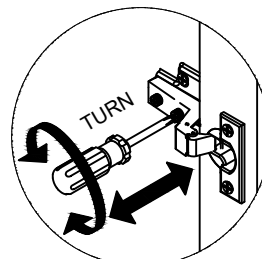

Loosen this screw for a slight left-right adjustment of the door.

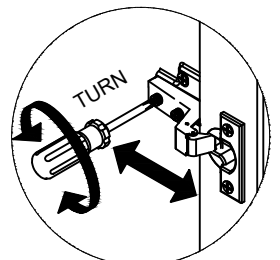

Loosen this screw and push forward/backward for a slight front-back adjustment of the door.

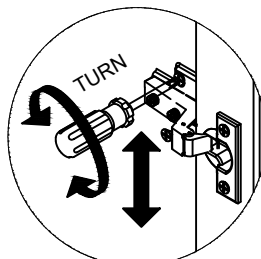
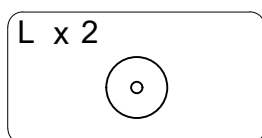
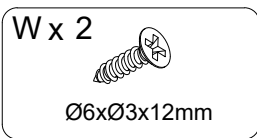
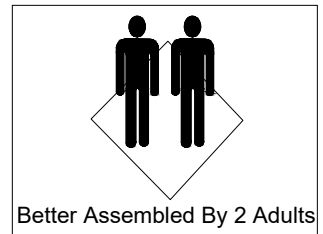
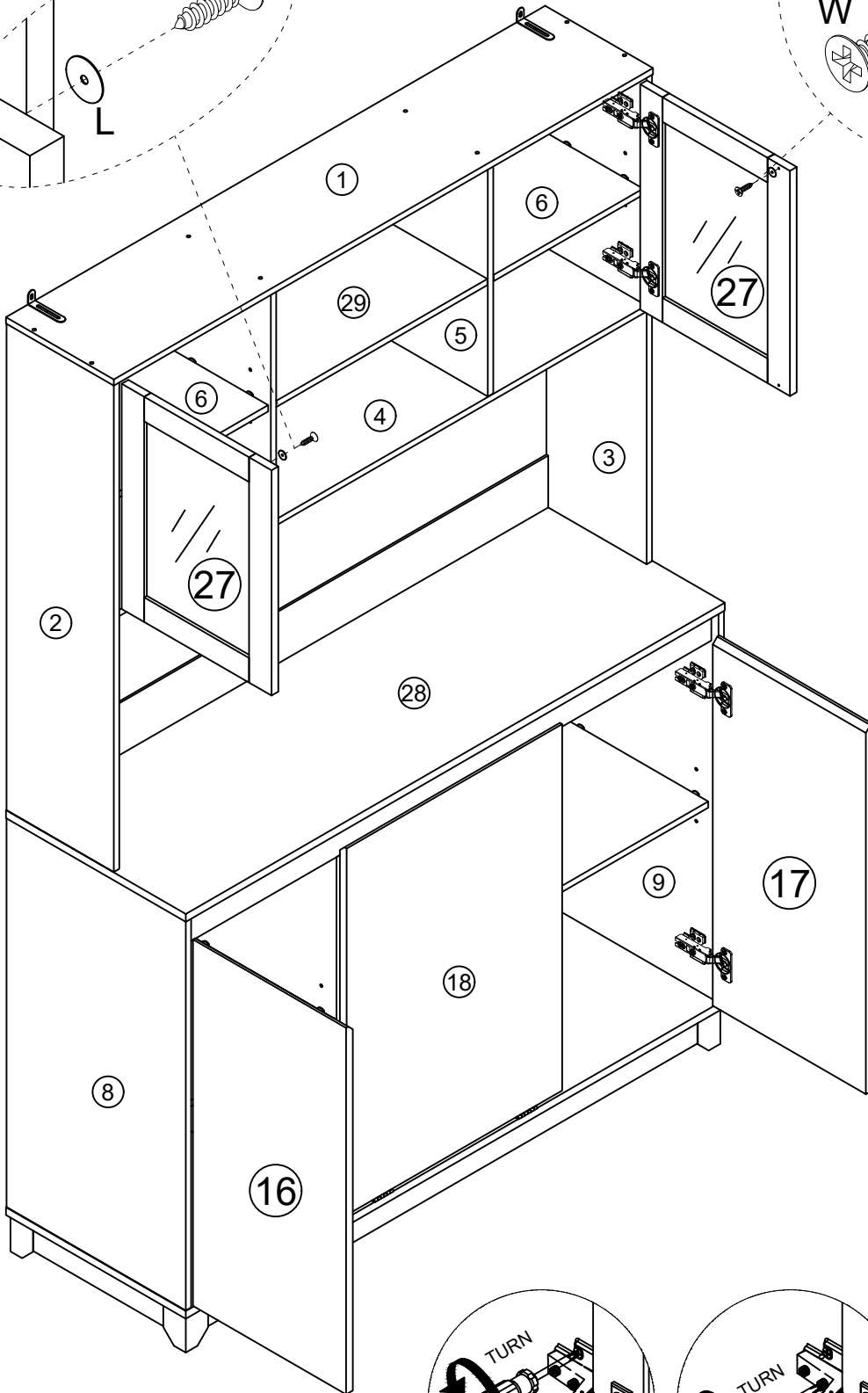
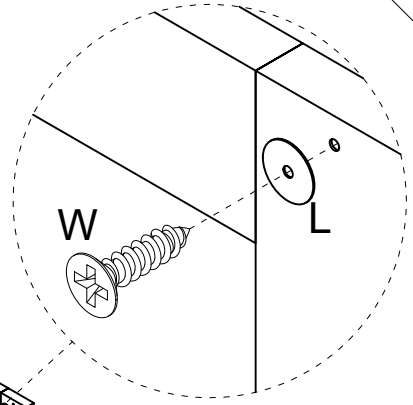
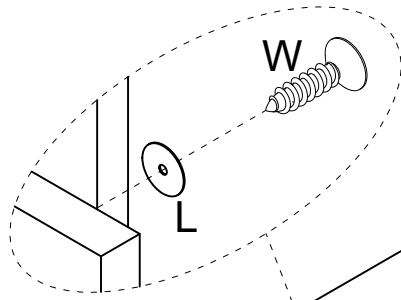
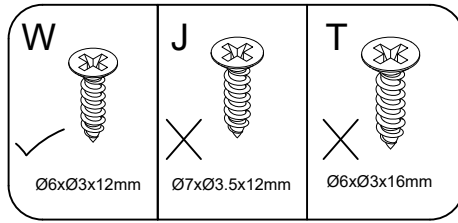

Loosen this screw and push up/down for a slight up-down adjustment of the door.

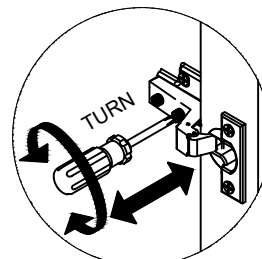

Loosen this screw for a slight left-right adjustment of the door.

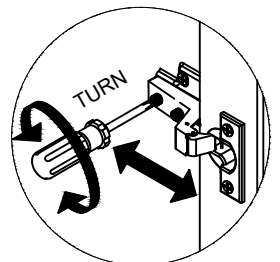

Loosen this screw and push forward/backward for a slight front-back adjustment of the door.

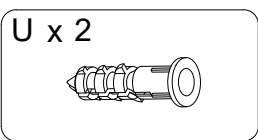
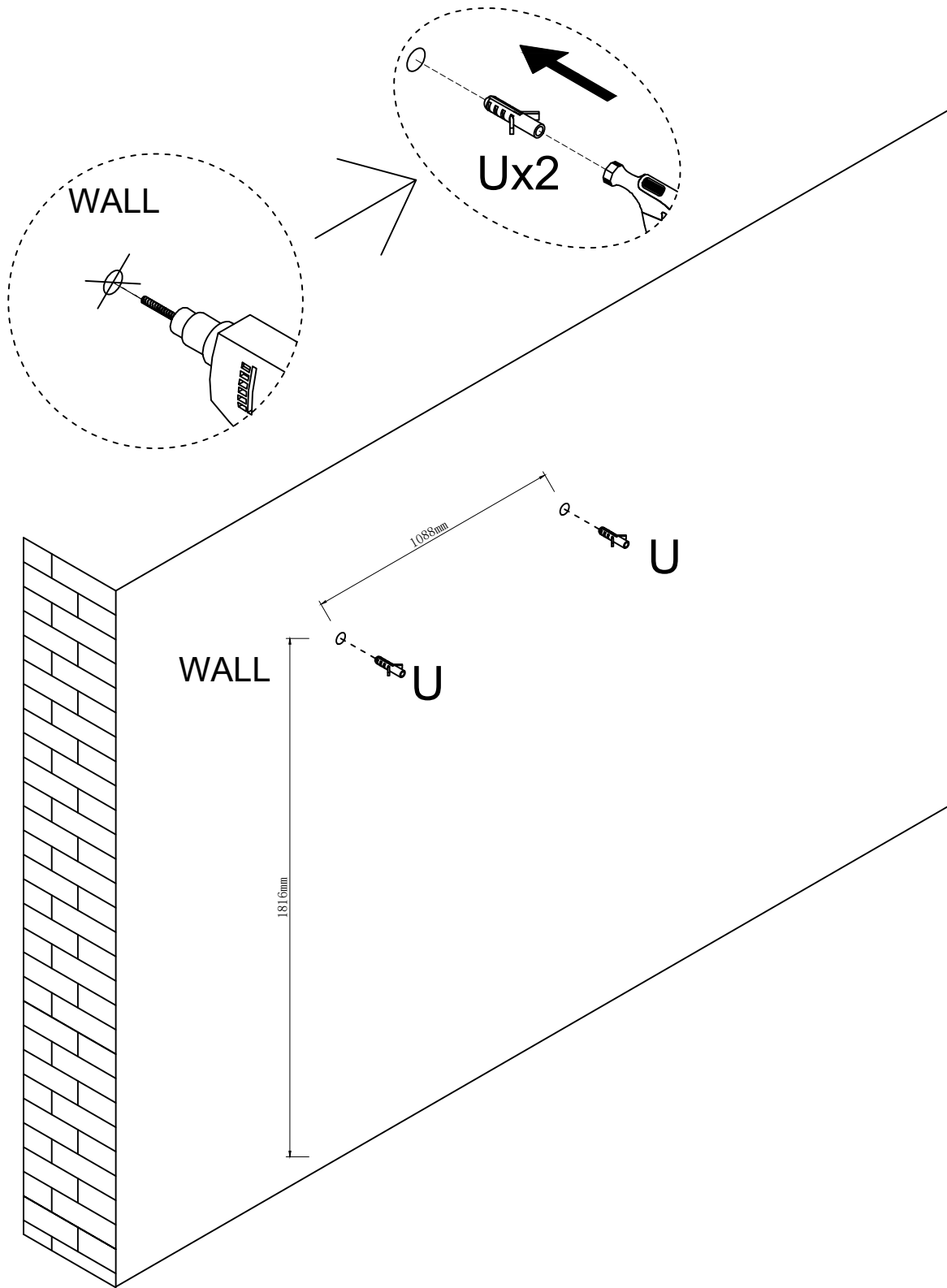

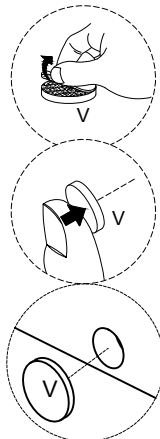
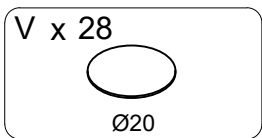
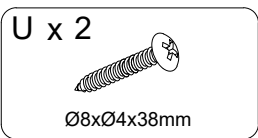
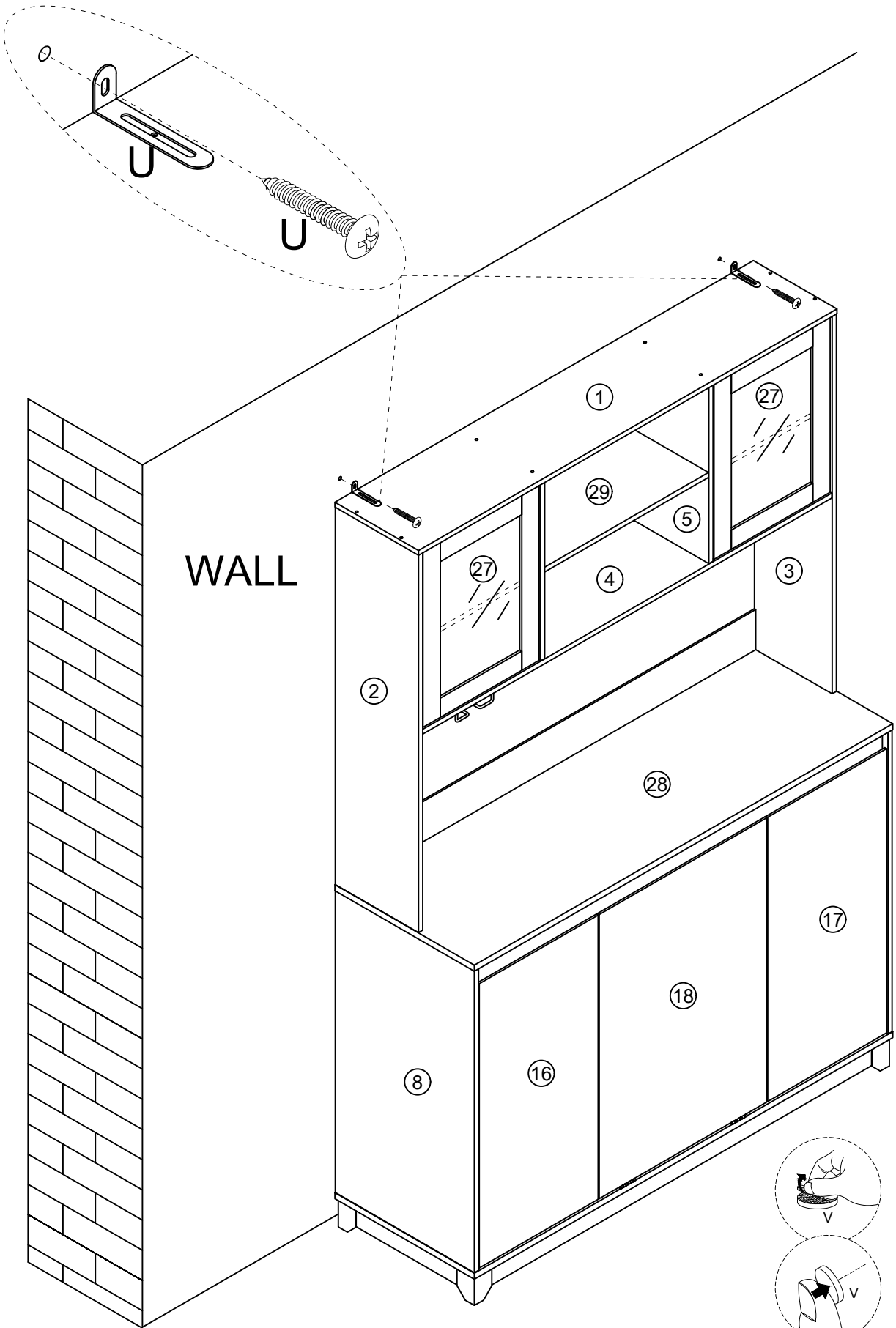

Exposed holes can be attached with stickers **V**

Shenzhen ZKT Technology Co., Ltd.
 1/F, No. 101, Building B, No. 6, Tangwei Community Industrial Avenue,
 Fuhai Street, Bao'an District, Shenzhen, China



Certificate of Compliance

Certificate Number: ZKT-2403202772C

- Certificate's Holder** : Shenzhen Pinchengxin Technology Co., Ltd
 3rd Floor, 8th Building Yuanling Industrial Zone, No. 39
 Yuanlingcun Road, Shiyan Street, Bao'an District,
 Shenzhen
- Manufacturer** : Shenzhen Pinchengxin Technology Co., Ltd
 3rd Floor, 8th Building Yuanling Industrial Zone, No. 39
 Yuanlingcun Road, Shiyan Street, Bao'an District,
 Shenzhen
- Trade Mark** : N/A
- Product** : 5050 RGB LED Strip Lights with Bluetooth App Controller
 and 2.4G Remote
- Model(s)** : 5050 RGB LED Strip Lights
- Test Standard** :
- | | | |
|------------|--------|---|
| Art.3.1(a) | Safety | EN IEC 62368-1:2020+A11:2020 |
| Art.3.1(a) | Health | EN IEC 62311:2020
EN 50665:2017 |
| Art.3.1(b) | EMC | ETSI EN 301 489-1 V2.2.3 (2019-11)
ETSI EN 301 489-17 V3.2.4 (2020-09) |
| Art.3.2 | Radio | ETSI EN 300 328 V2.2.2 (2019-07) |

This Attestation of Compliance is issued on a voluntary basis for electrical equipment below the voltage limits of Radio Equipment Directive (RED) 2014/53/EU. The essential requirements are fulfilled accordingly based on the technical specifications applicable at the time of issuance.



This Certificate of Conformity is based on single evaluation of the submitted sample(s) of the above mentioned product. It does not imply an assessment of the whole product and relevant Directives to be observed.