

---

# User Manual

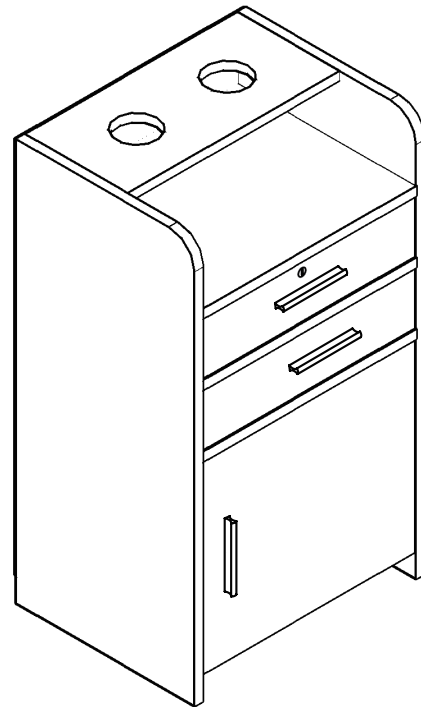

# You need

**1 Tools required**

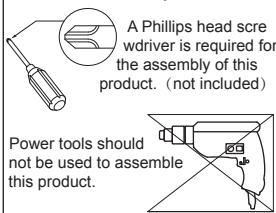

A Phillips head screwdriver is required for the assembly of this product. (not included)

Power tools should not be used to assemble this product.

**2 1 person is needed**



**3 Take 1 hour**







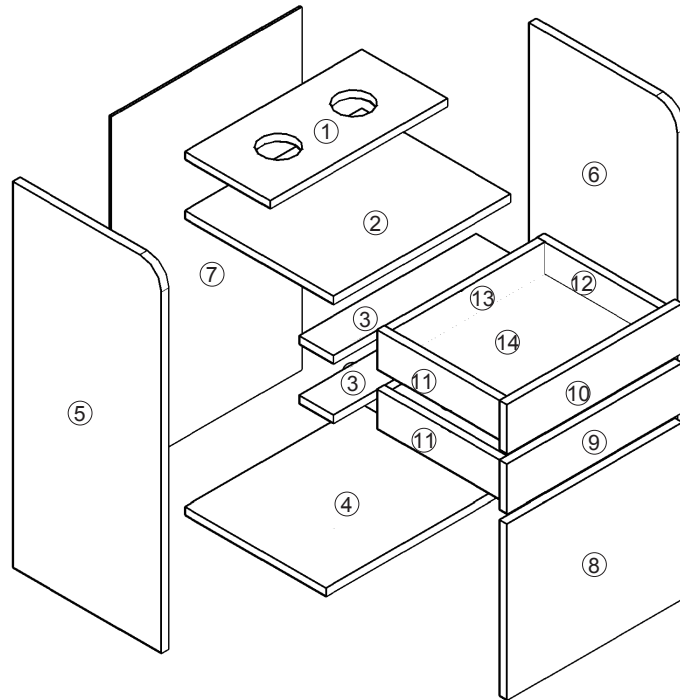

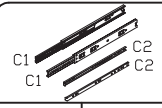
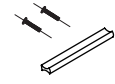

**1hour**

Technical Specifications	
Brand	SANDINRAYLI
Material	Particle board+MDF
Size	450*350*800MM

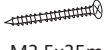
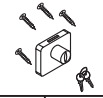



# Hardware List

			
A 28PCS	B 6PCS	C 4PCS	D 3PCS
			
E 2PCS	F 44PCS M3.5x14mm	G 8PCS M3.5x35mm	H 1PC
			
I 4PCS	J 2PCS	K 30PCS	

PRODUCT ASSEMBLY

 Check the package contents before getting started!

**STEP 1**

 C1 C2 C1 C2	 M3.5x14mm	 I
C   4PCS	F   24PCS	I   4PCS

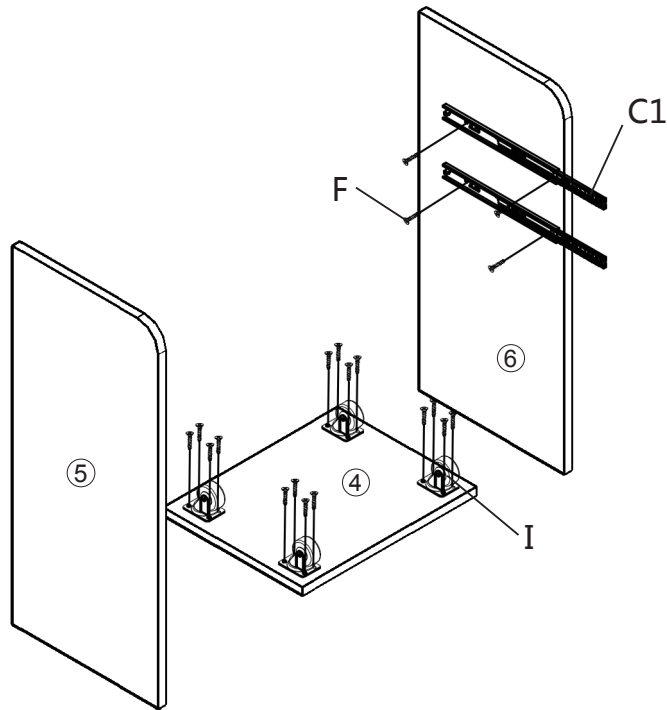

PRODUCT ASSEMBLY

**STEP 2**

 A	 B
20PCS	6PCS

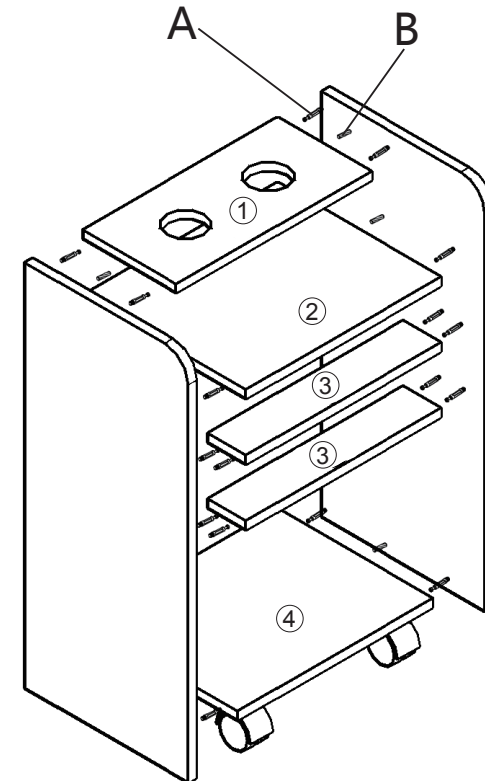



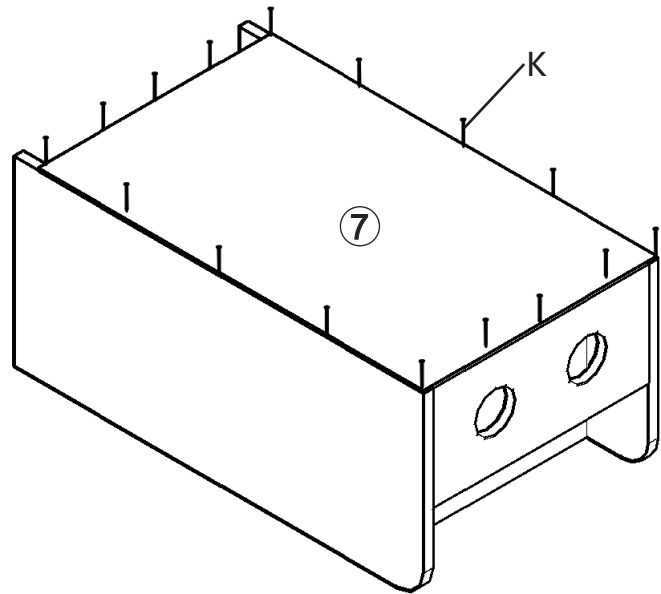
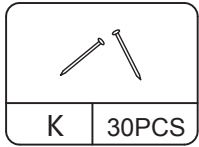

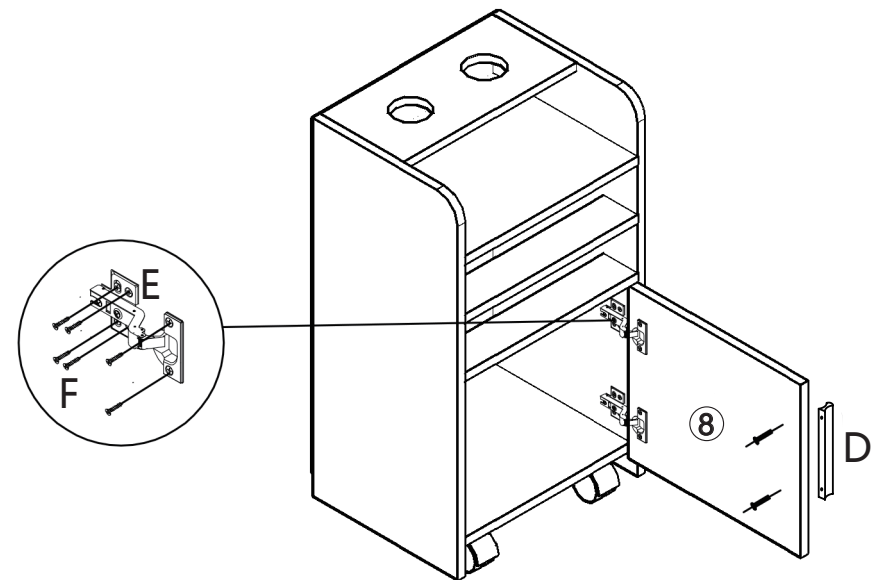
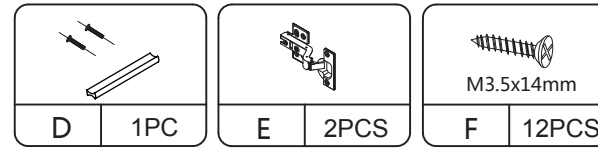

### STEP 3



### STEP 4

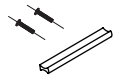

### STEP 5

			
A   8PCS	C   4PCS	D   2PCS	F   8PCS
			
G   8PCS	H   1PC		

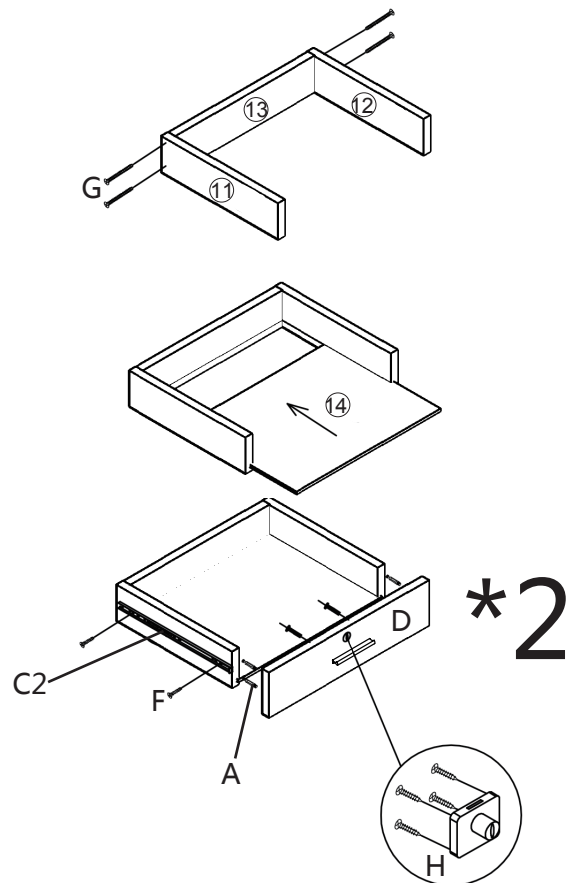

### STEP 6

	
J   2PCS	

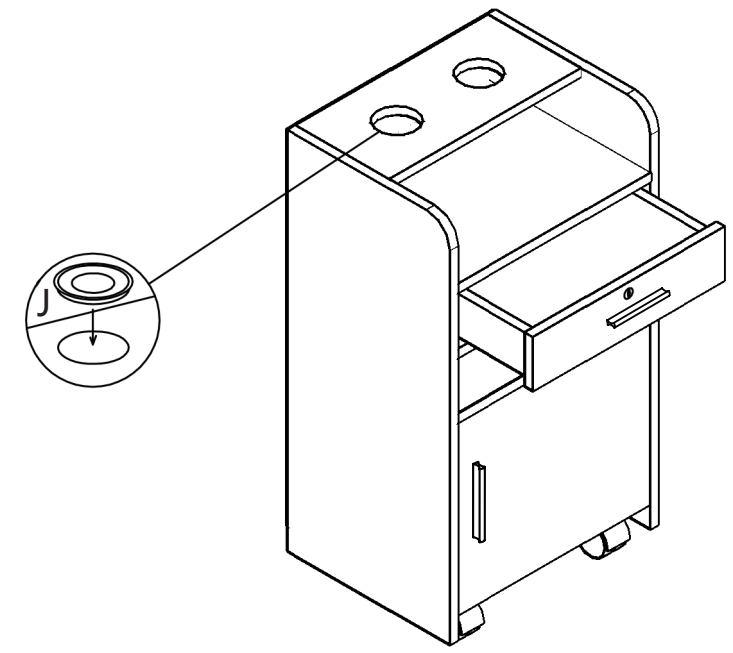

STEP 7

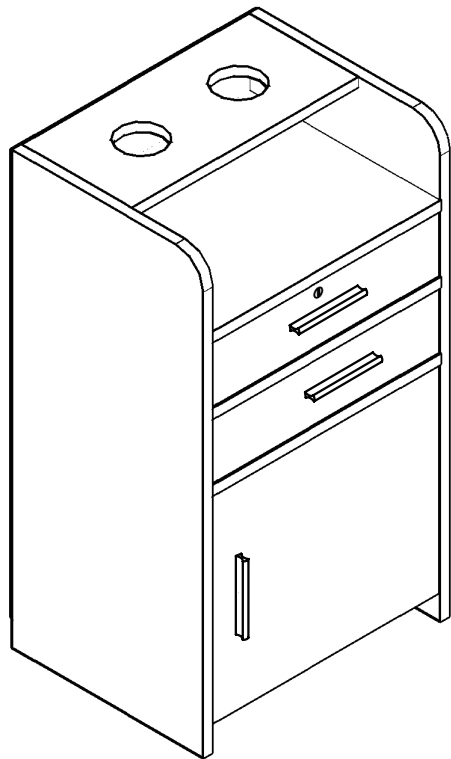

STEP 8

