

# Assembly Instructions

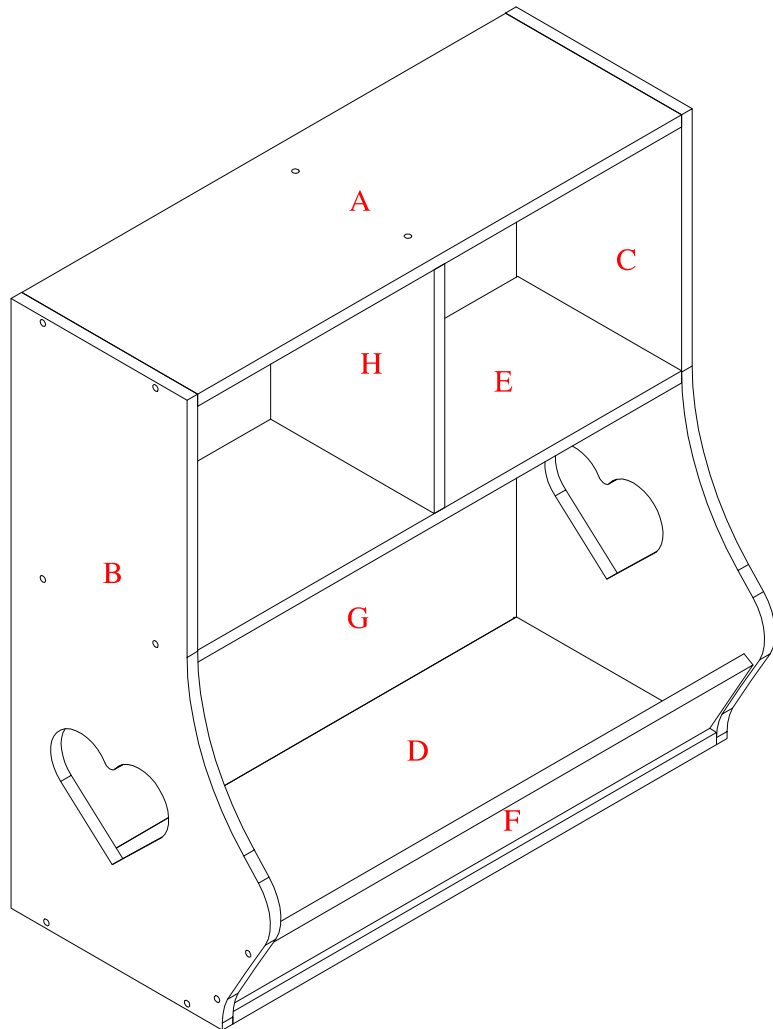

# PARTS LIST

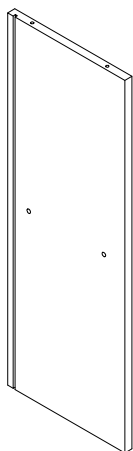

**A** x 1pc

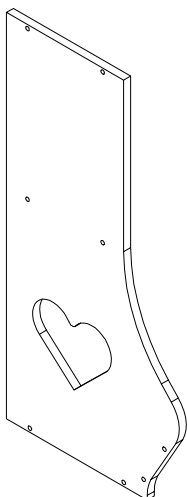

**B** x 1pc

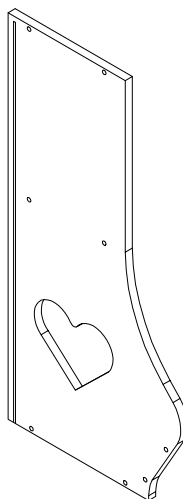

**C** x 1pc

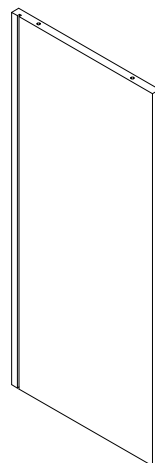

**D** x 1pc

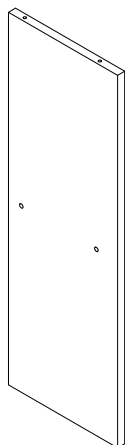

**E** x 1pc



**F** x 1pc



**G** x 2pcs

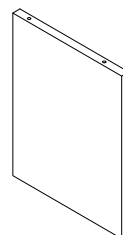

**H** x 1pc

# HARDWARE LIST



M5 x 40mm

① x 20pcs

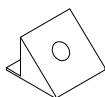

M3 x 16mm

② x 6pcs

M3



③ x 1pc



④ x 1pcs

# STEP 1

A x 1pc

B x 1pc

C x 1pc

① x 4pcs

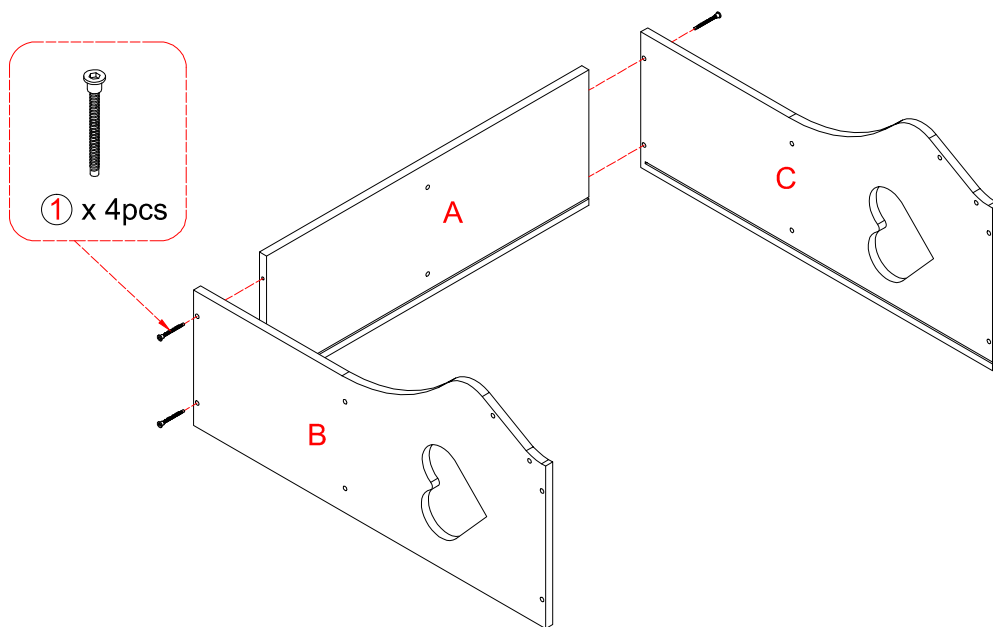

# STEP 2

E x 1pc

① x 4pcs

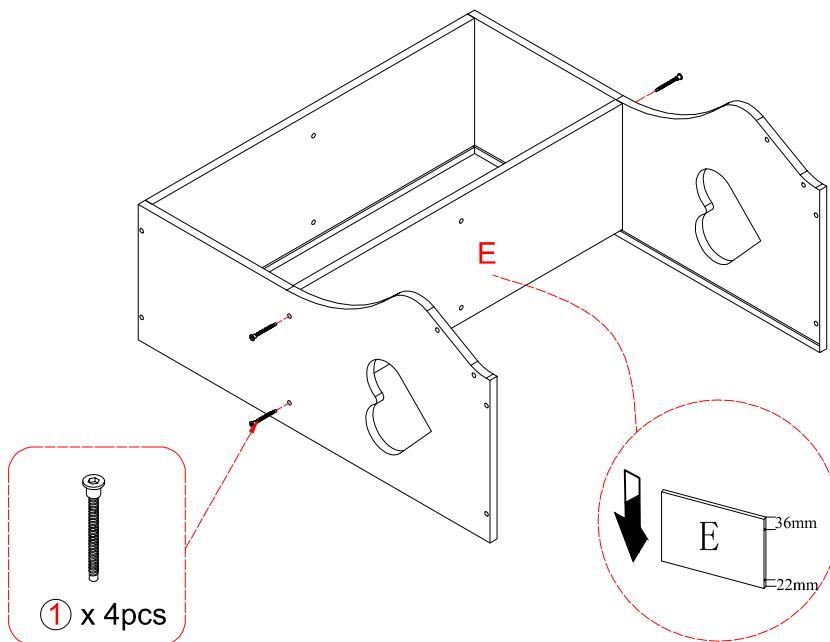

# STEP 3

H x 1pc

① x 4pcs

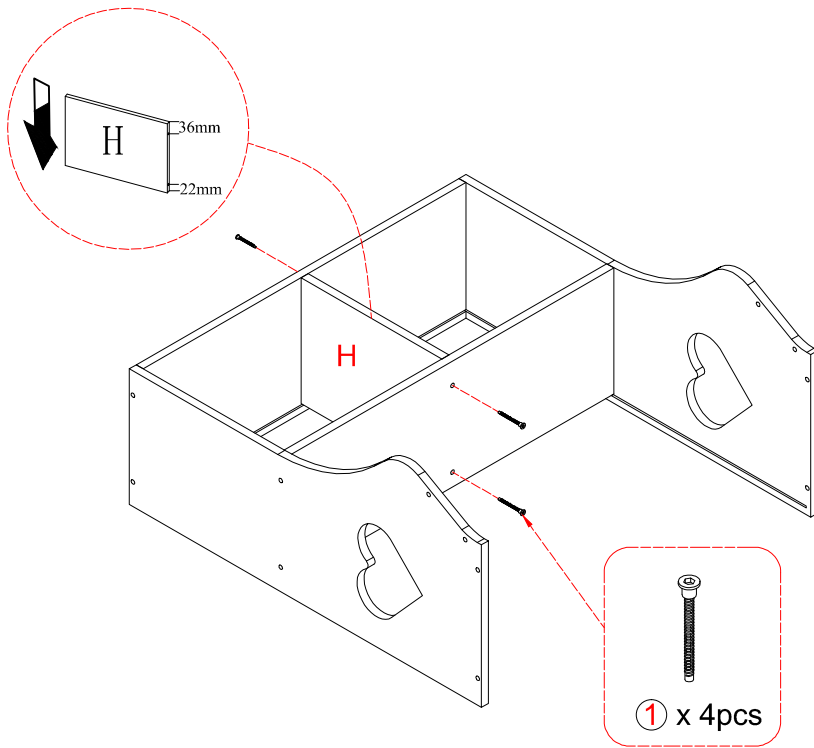

# STEP 4

F x 1pc

① x 4pcs

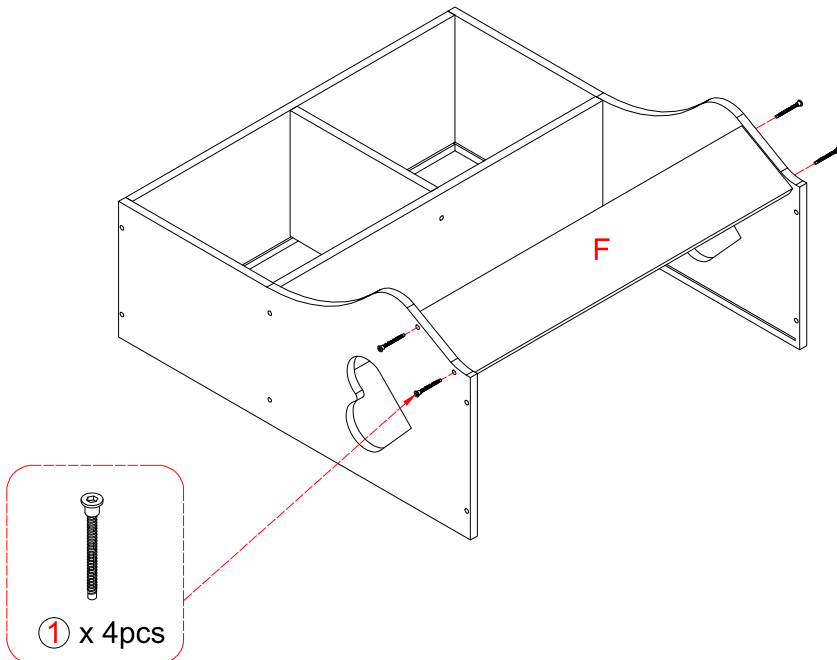

# STEP 5

G x 2pcs
④ x 1pc

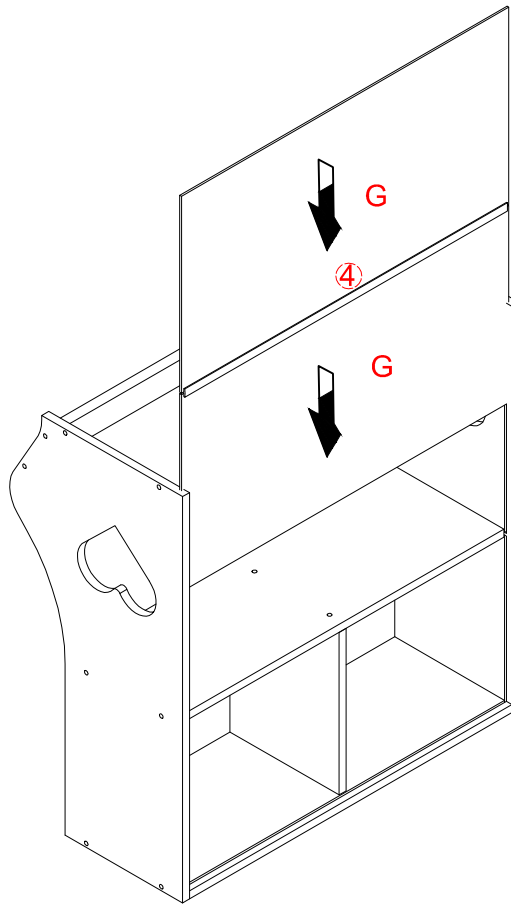

# STEP 6

D x 1pc
① x 4pcs

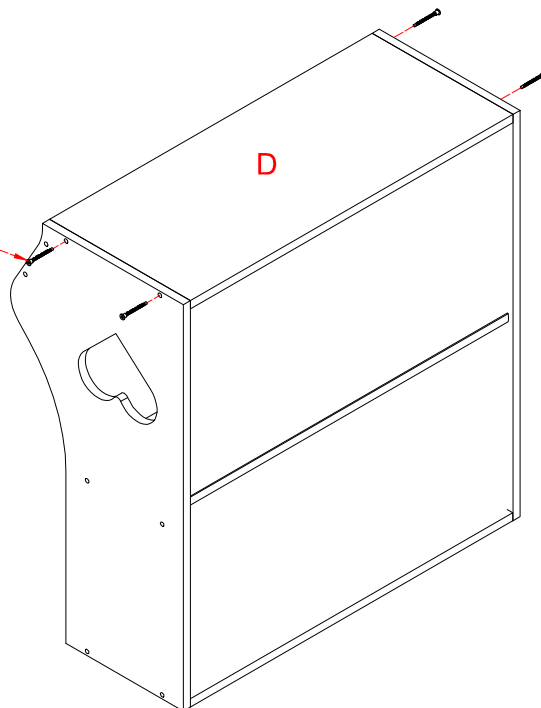
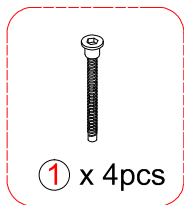

# STEP 7

② x 6pcs

