

# Assembly Instruction of (Cabinet)

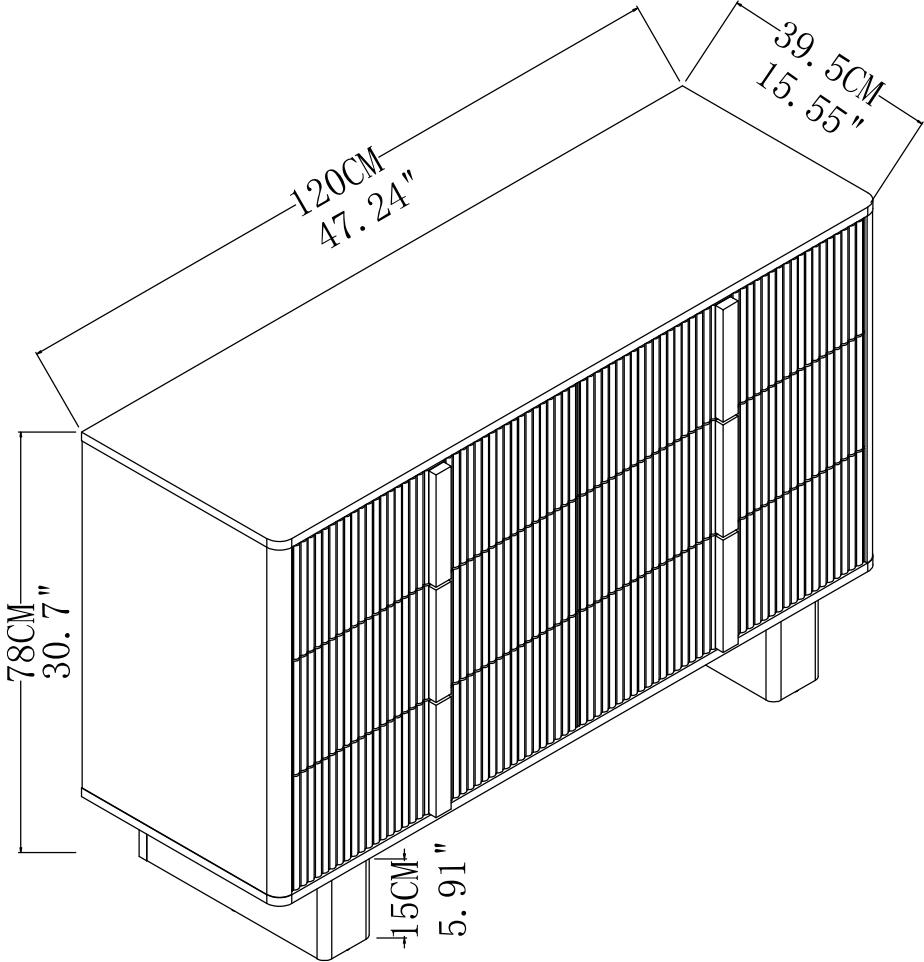

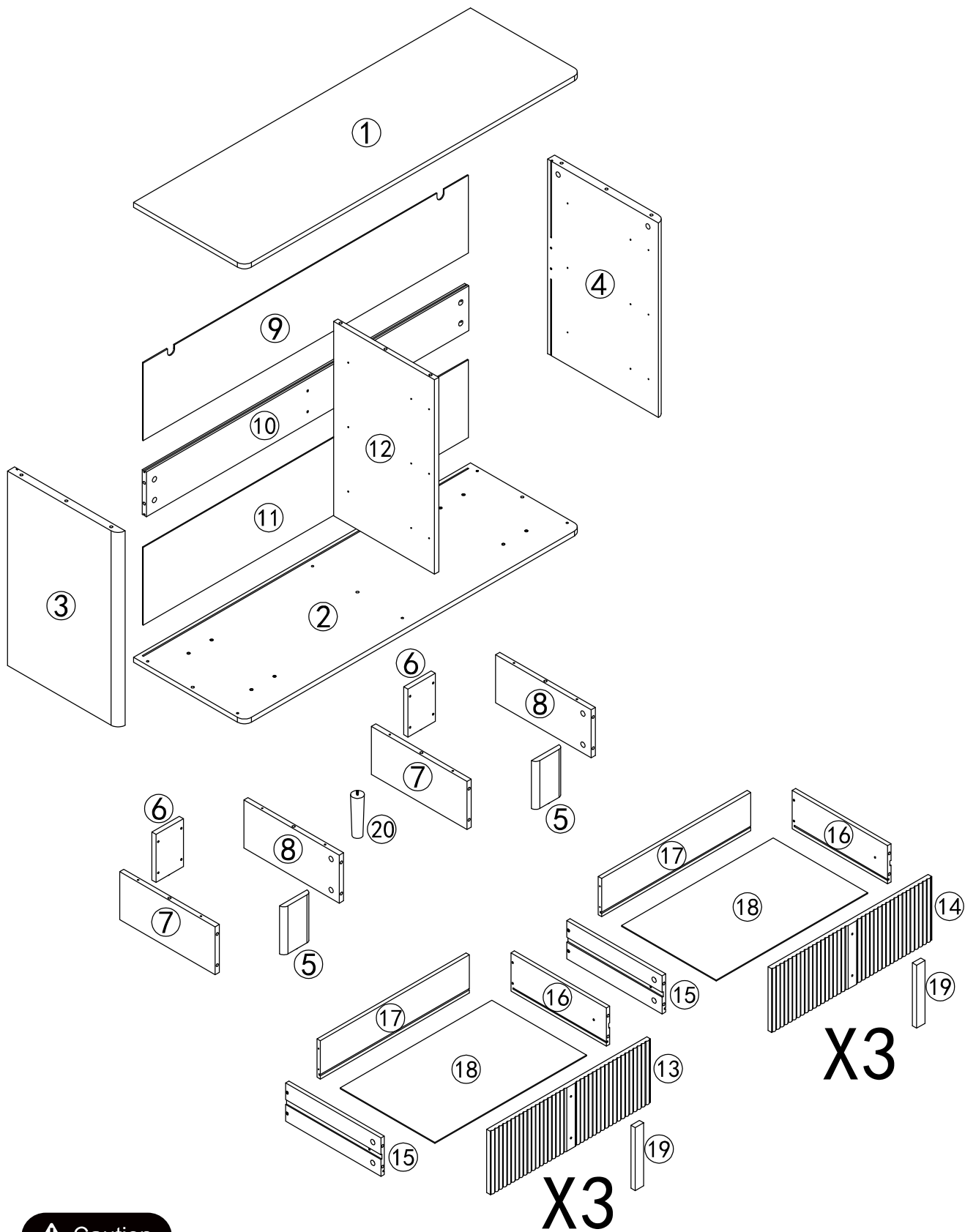







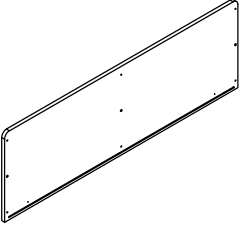
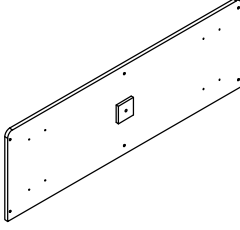

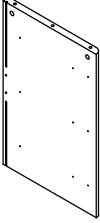
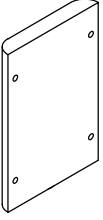
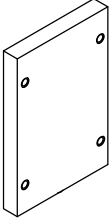
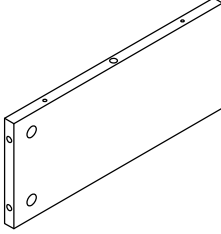
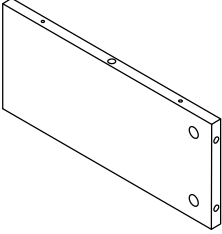
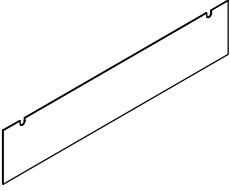
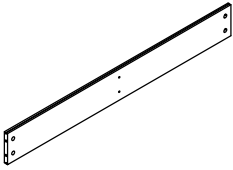
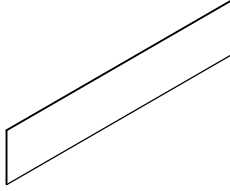
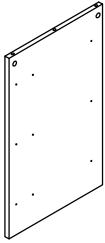
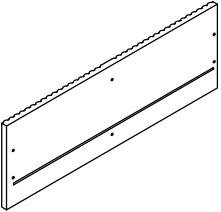
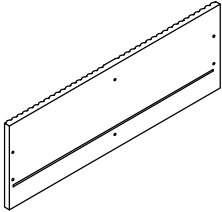
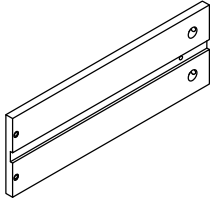
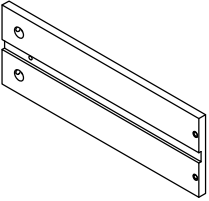
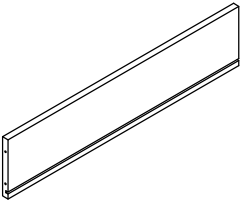
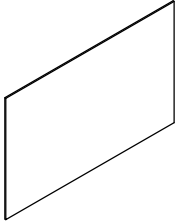

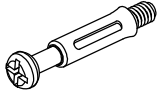
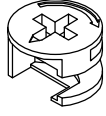

**⚠ Caution**

Please ensure all parts are included. Most board components are labeled or stamped on the raw edges. If you find any damaged or missing parts, feel free to contact us for a free replacement.

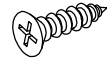
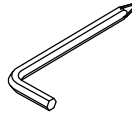
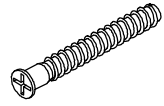
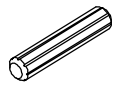
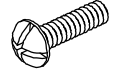
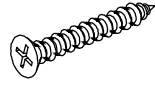
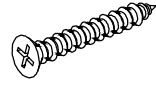
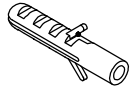
# Parts List

			
① 1PC	② 1PC	③ 1PC	④ 1PC
			
⑤ 2PCS	⑥ 2PCS	⑦ 2PCS	⑧ 2PCS
			
⑨ 1PC	⑩ 1PC	⑪ 1PC	⑫ 1PC
			
⑬ 3PCS	⑭ 3PCS	⑮ 6PCS	⑯ 6PCS
			
⑰ 6PCS	⑱ 6PCS	⑲ 6PCS	⑳ 1PC

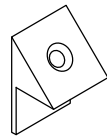

# Hardware List

A	B	C	D	E	F
					
M6x35mm	Ø15x9mm	Silver Color M3.5x14mm	Black Color M3x16mm	4mm	M5x40mm
42PCS	42PCS	36PCS	8PCS	1PC	24PCS
G	H	I	J	K	M
					
Ø8x30mm	M4x10mm	M4x25mm	M4x35mm	Ø6x30mm	
10PCS	12PCS	12PCS	26PCS	2PCS	2PCS
N	O	P	Q		
					
M4x12mm			M6x20mm		
2PCS	12PCS	8PCS	1PC		

# STEP 1

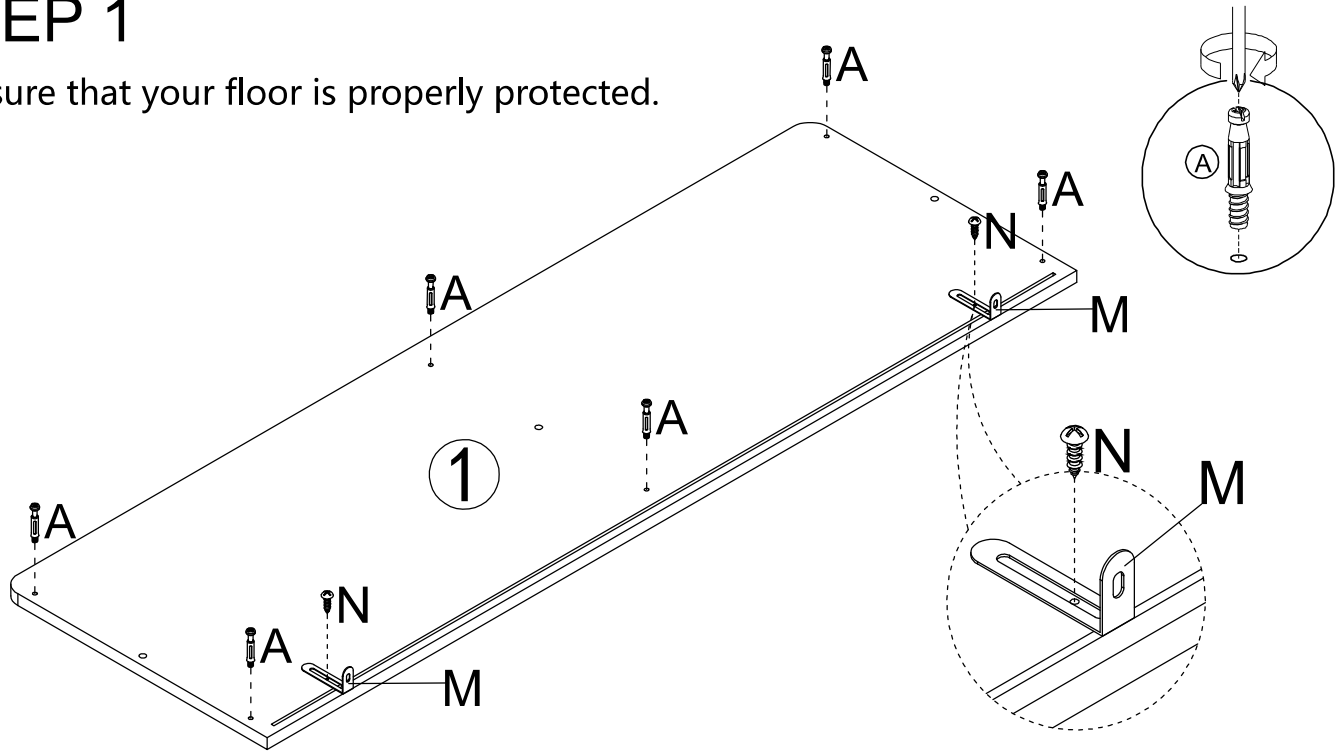
Ensure that your floor is properly protected.



A	x6	M	x2	N	x2
					
M6x35mm				M4x12	

# STEP 2

Ensure that your floor is properly protected.

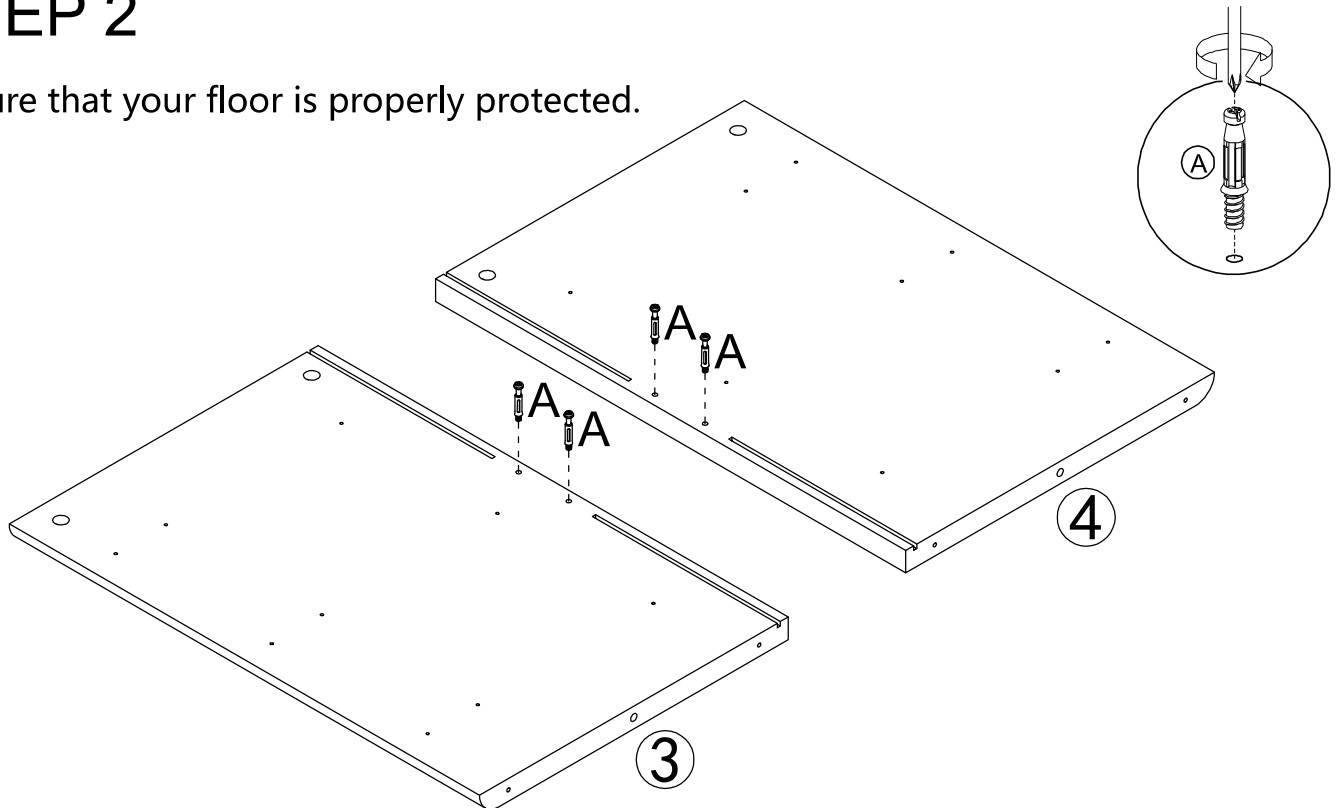

A	x4
	
M6x35mm	



# STEP 4

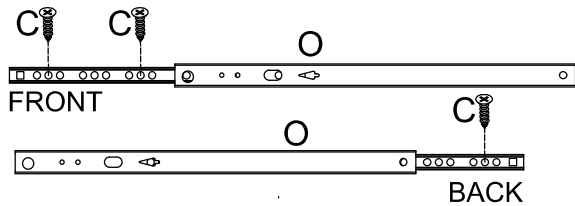

Pay close attention: the screw positions on each side of board #12 are different.

NOTE: This locking step for slide rail only applies to the board side with the cam lock holes.

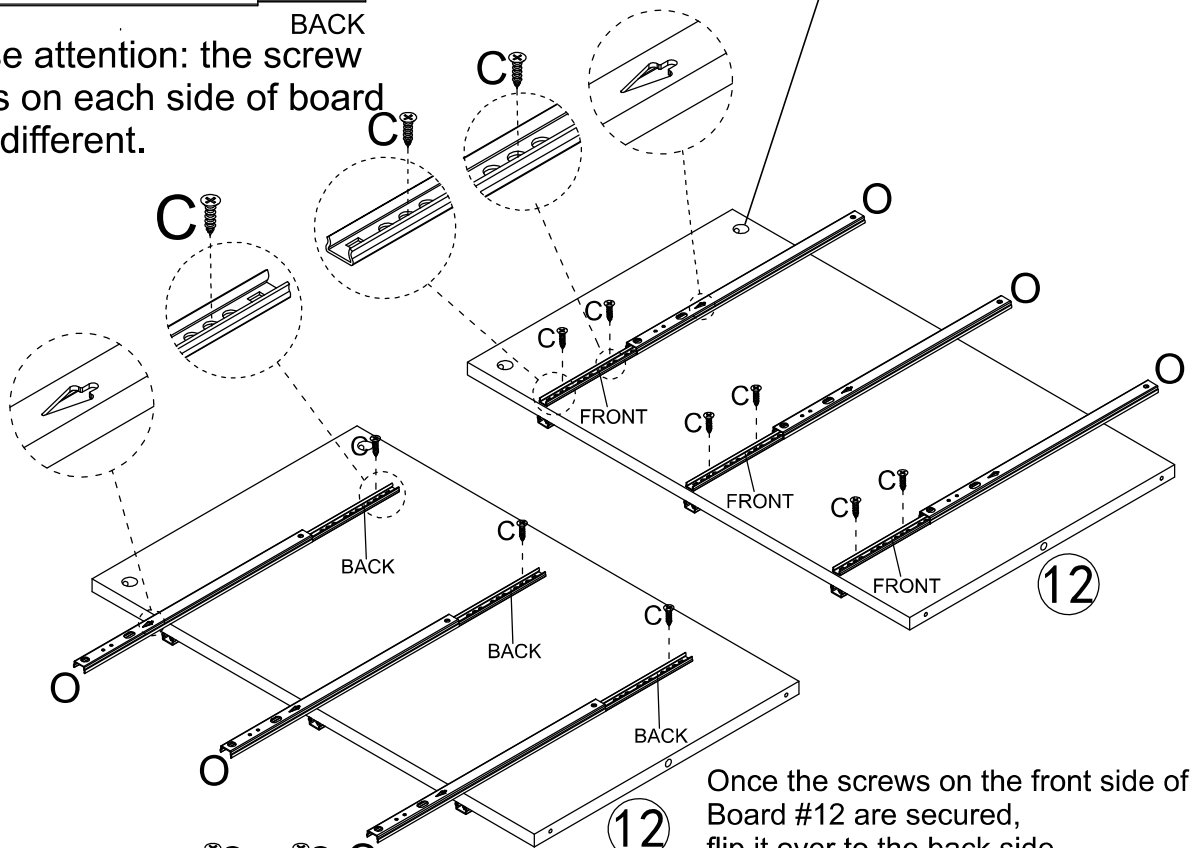

Once the screws on the front side of Board #12 are secured, flip it over to the back side to attach the slides.

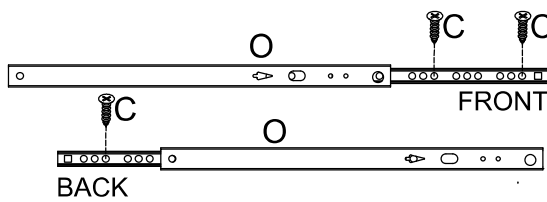

Pay close attention: the screw positions on each side of board #12 are different.

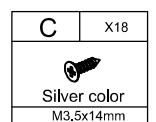
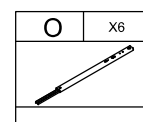
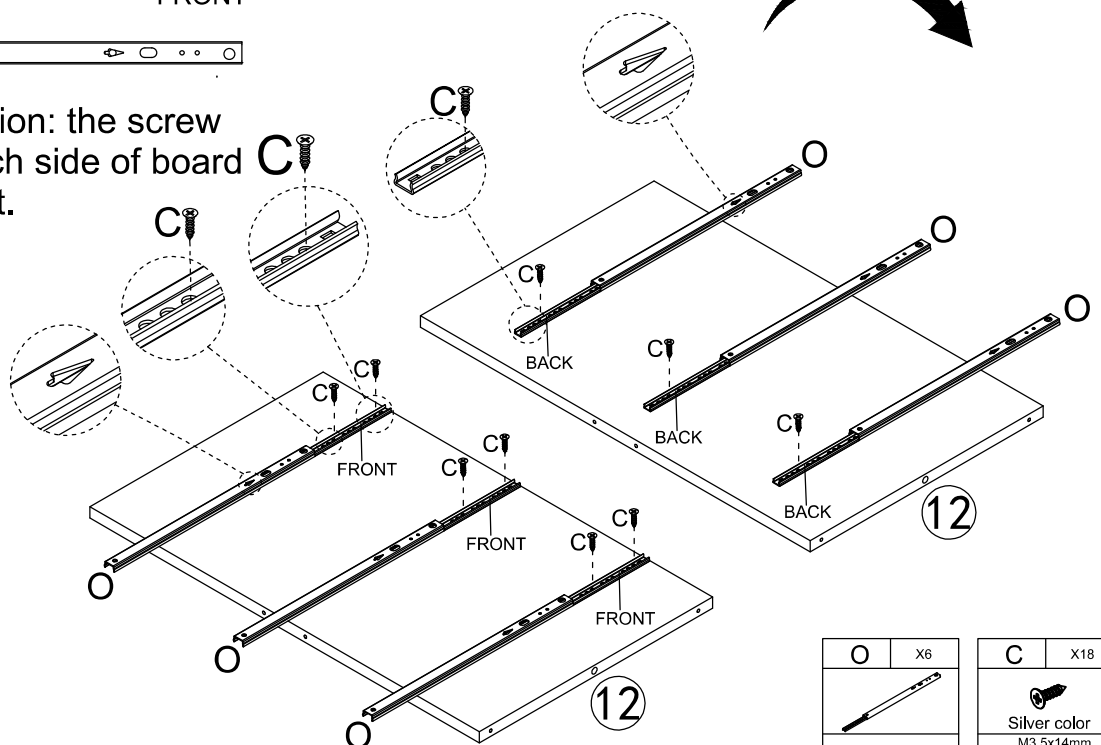

# STEP 5

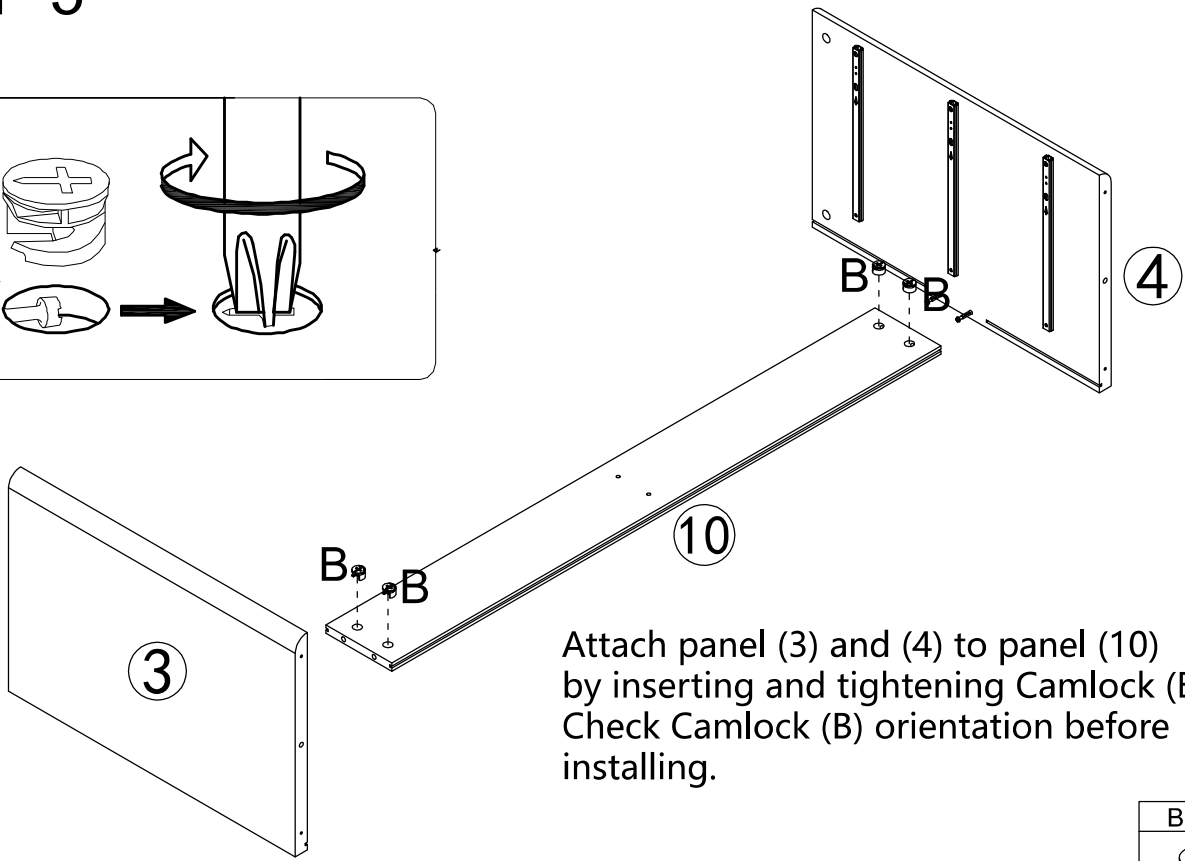
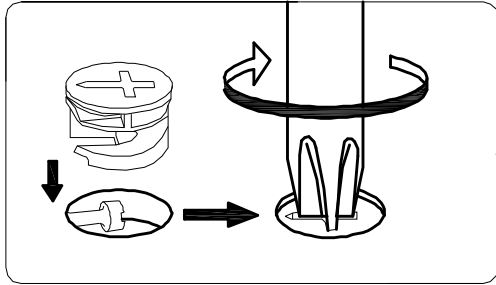

Attach panel (3) and (4) to panel (10) by inserting and tightening Camlock (B). Check Camlock (B) orientation before installing.

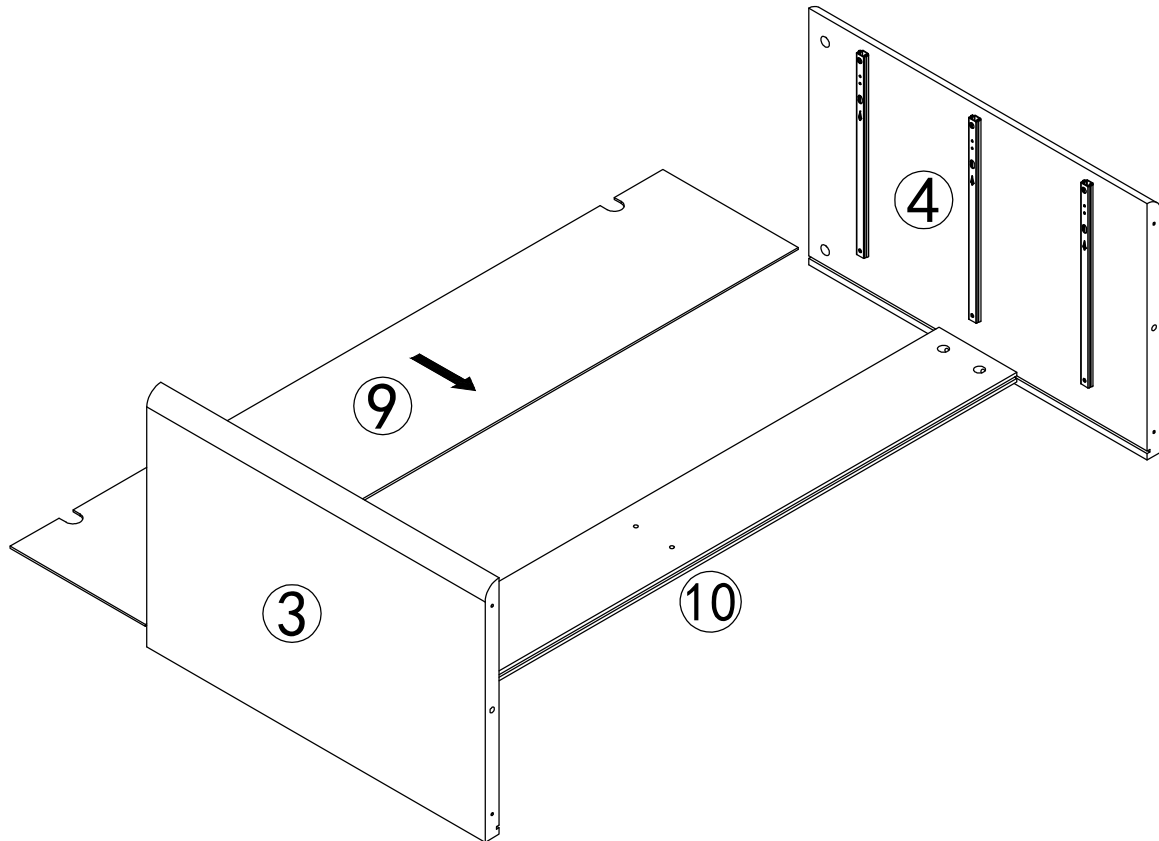

B	x4

# STEP 6



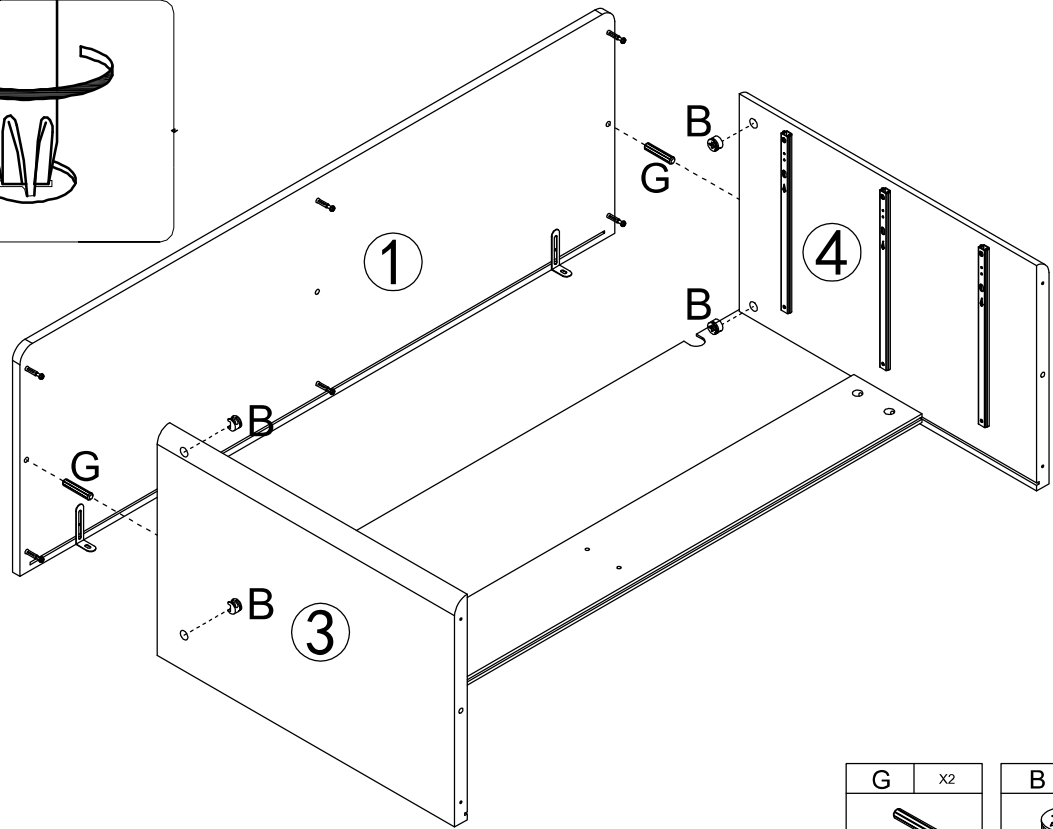
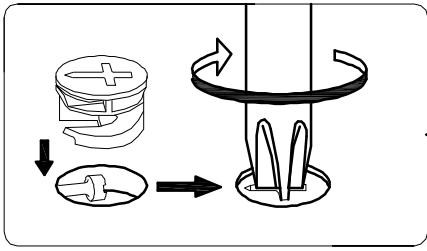

# STEP 7

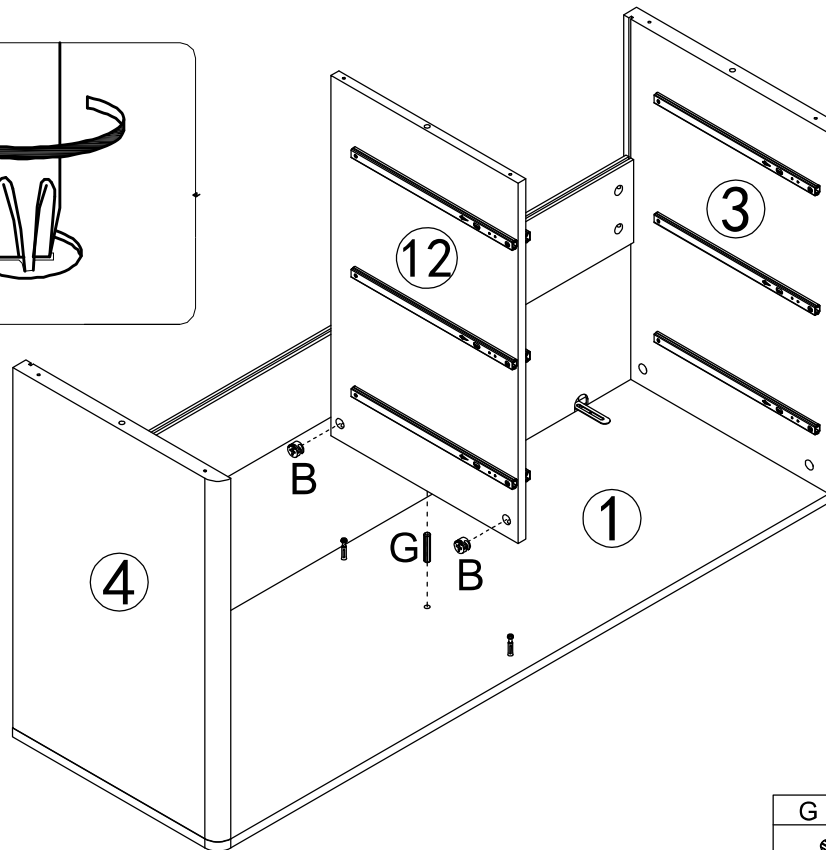
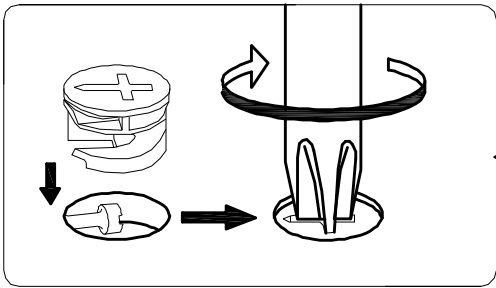

G	x2	B	x4
			

# STEP 8



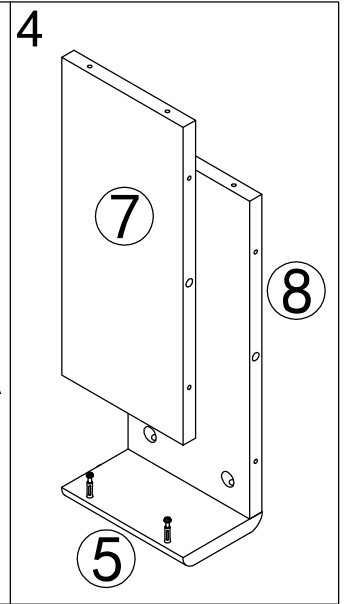
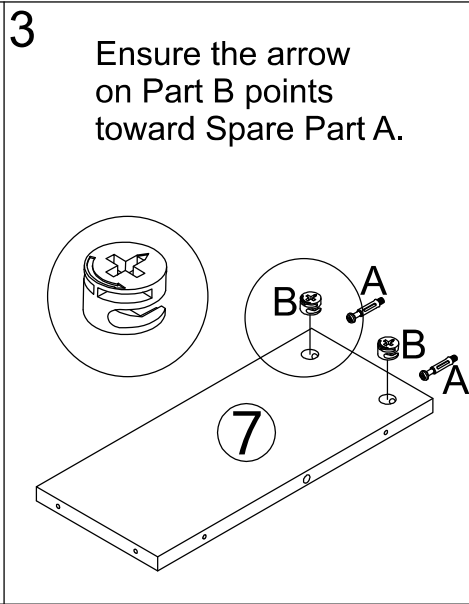
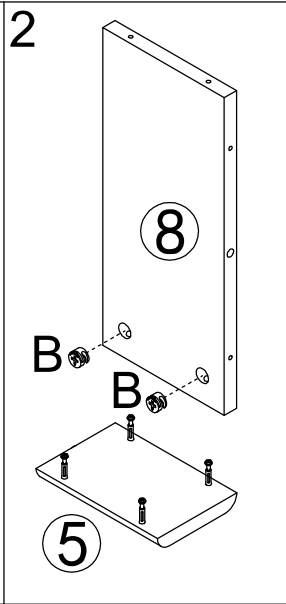
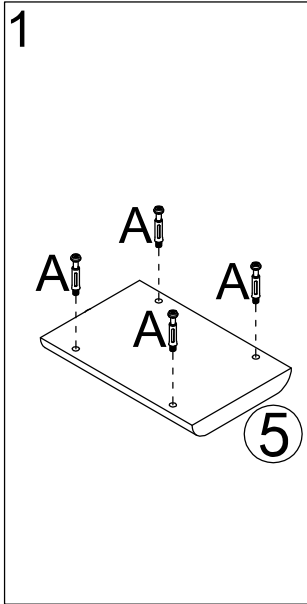
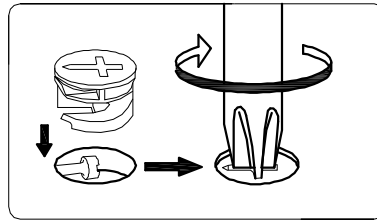
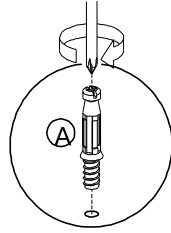

G	x1	B	x2
			

# STEP 9



X2

A	X8
	
M6x35mm	

B	X8
	

# STEP 10

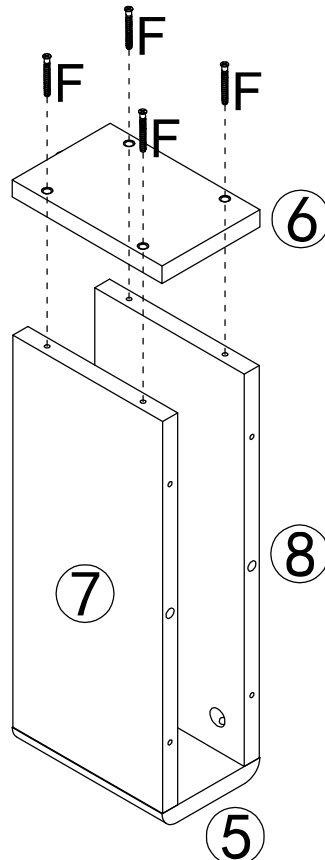



X2

F	X8
	
M5x40mm	

# STEP 11

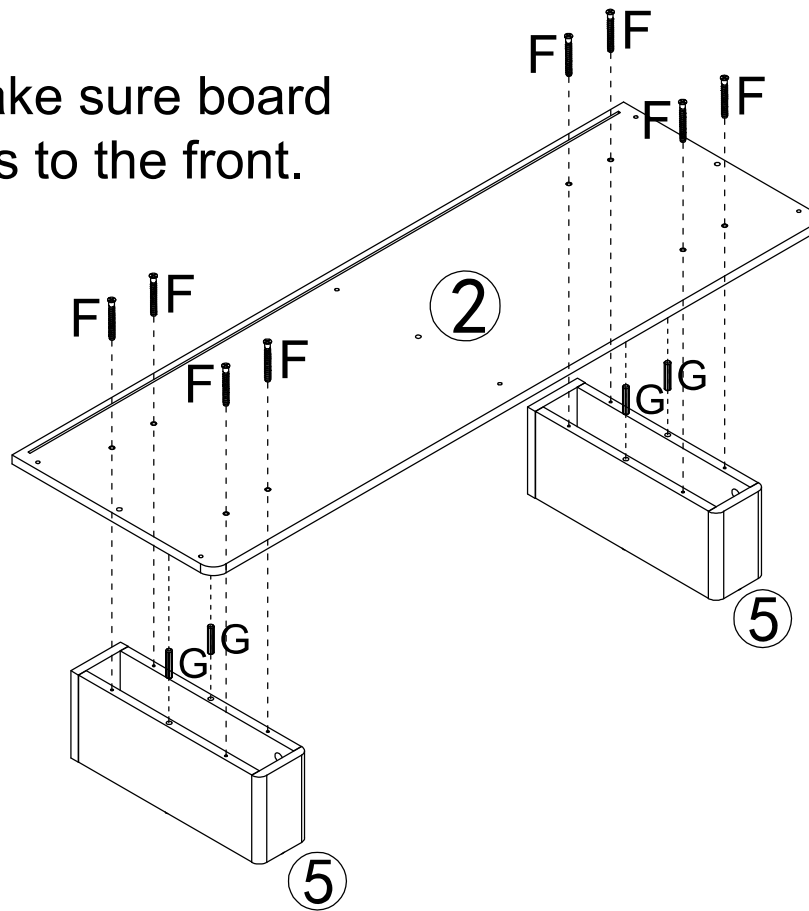
Please make sure board #5 towards to the front.



G	X4
	

F	X8
	
M5x40mm	

# STEP 12

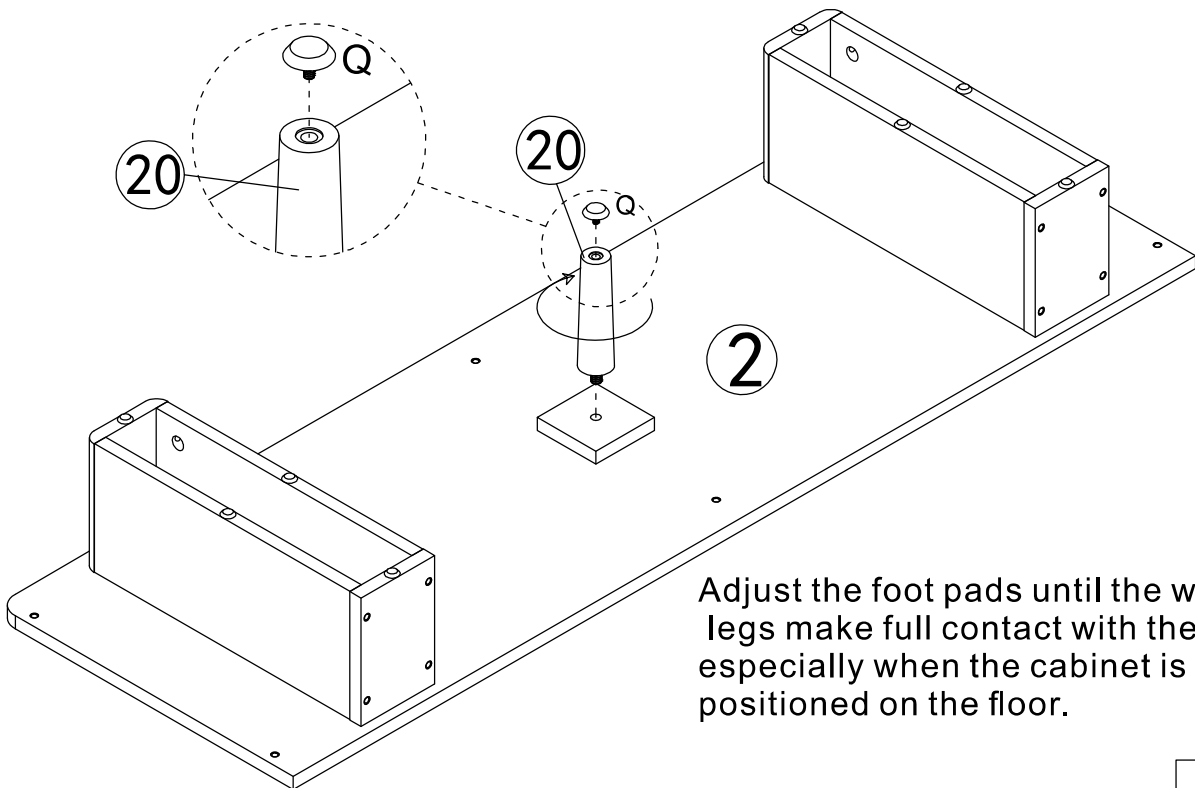

Adjust the foot pads until the wooden legs make full contact with the floor, especially when the cabinet is positioned on the floor.

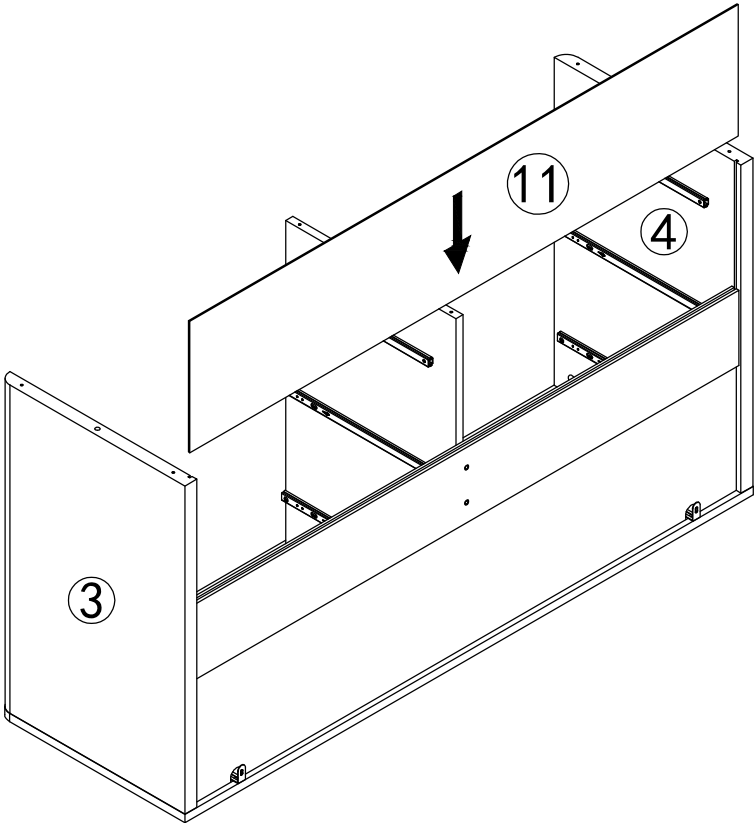

Q	X1
	
M6x18mm	

# STEP 13

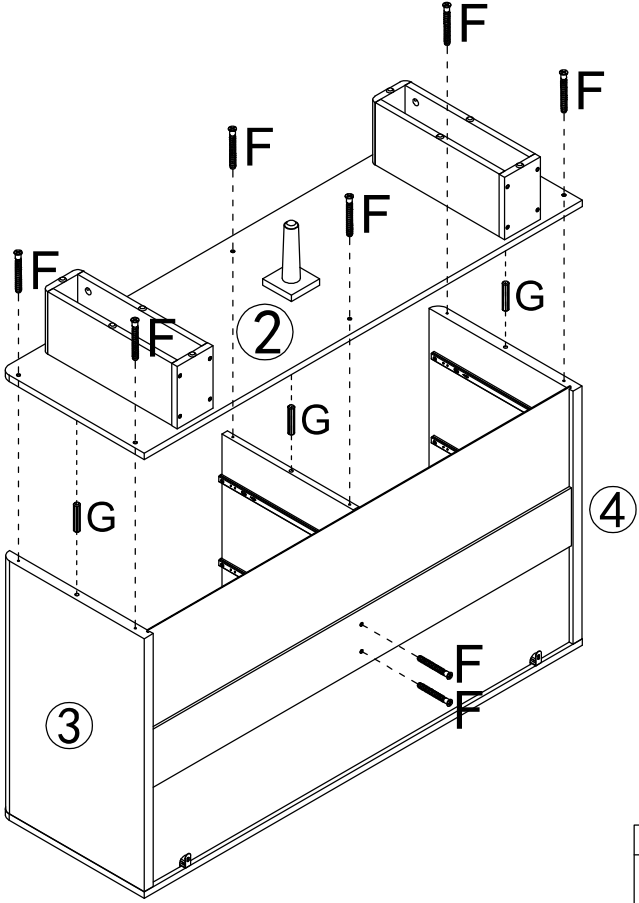

# STEP 14



G	x3	F	x8
			
		M5x40mm	

# STEP 15

Attention:  
Please secure the plastic  
buckles to side boards ③ and ④.

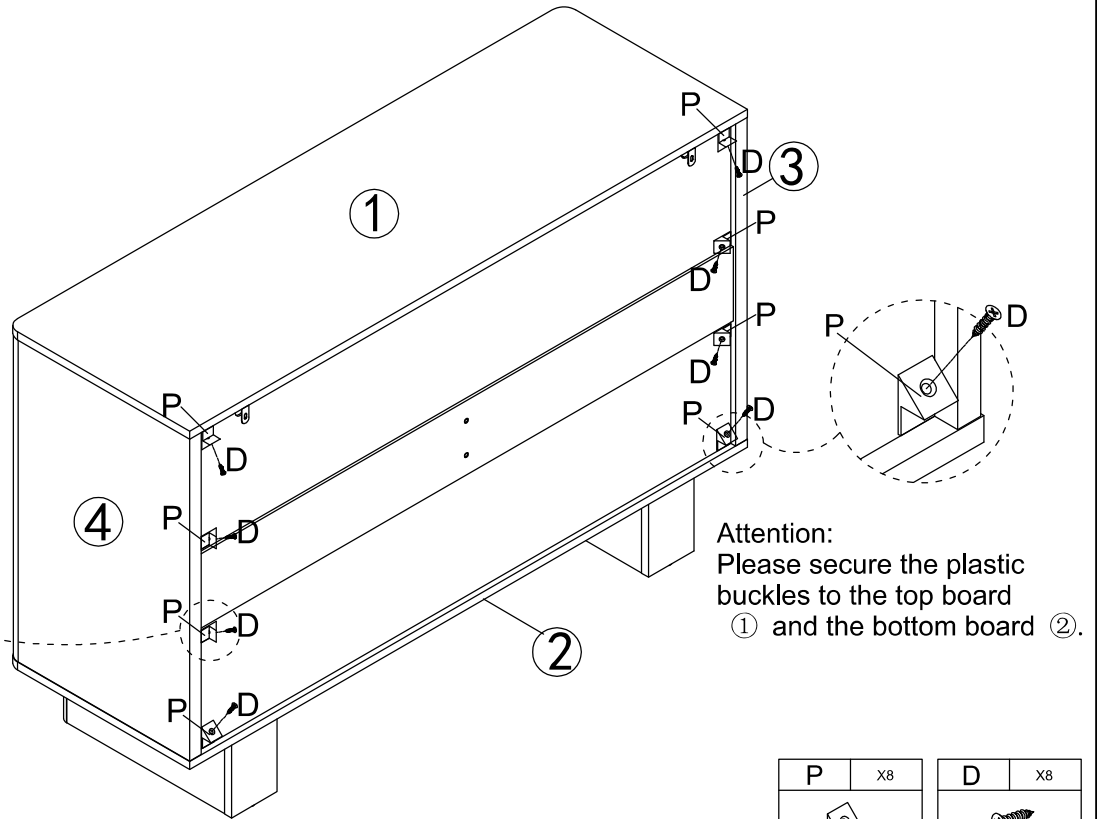
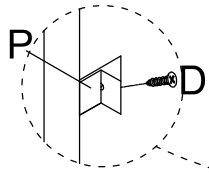

Attention:  
Please secure the plastic  
buckles to the top board  
① and the bottom board ②.

P	x8

D	x8
Black color M3x16mm	

# STEP 16

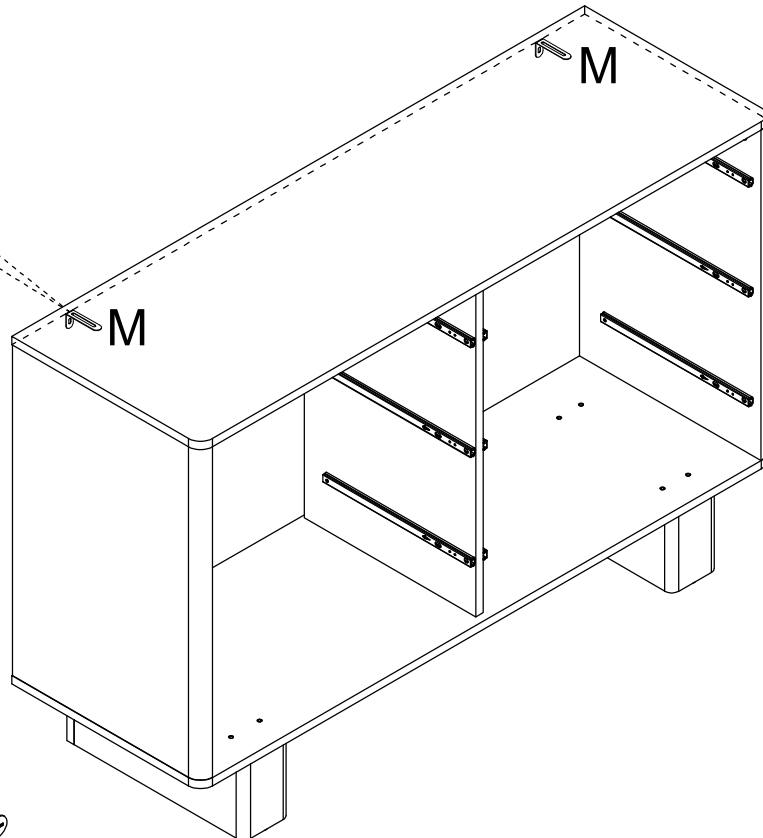
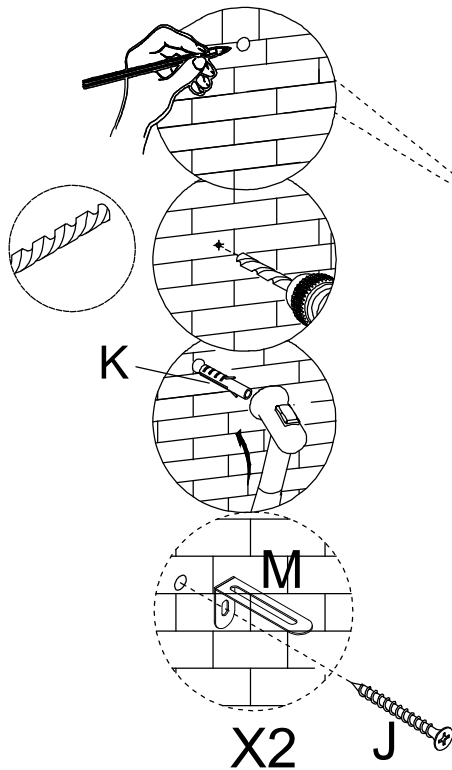



K	x2

J	x2
M4x35mm	

# STEP 17

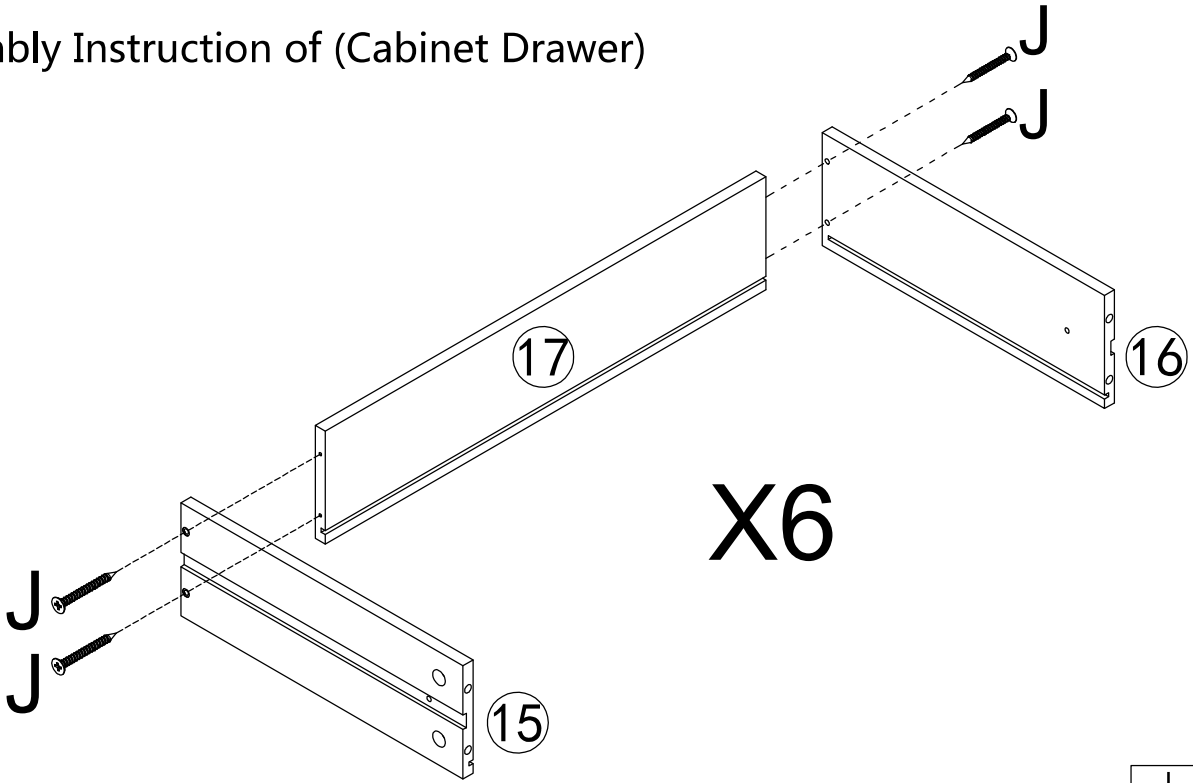
Assembly Instruction of (Cabinet Drawer)



J	X24
	
M4x35mm	

# STEP 18

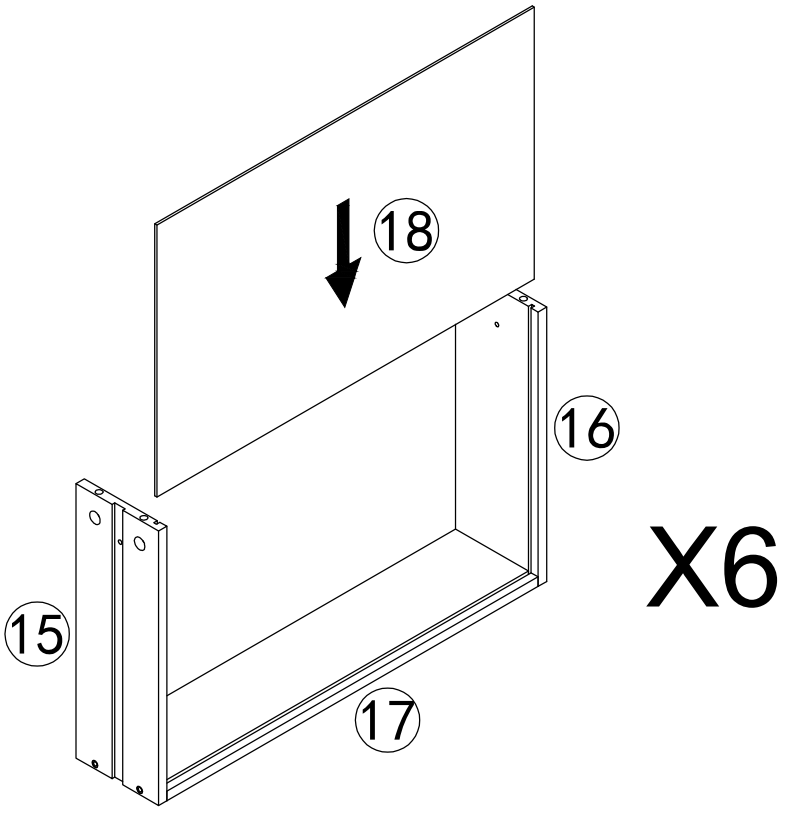

# STEP 19

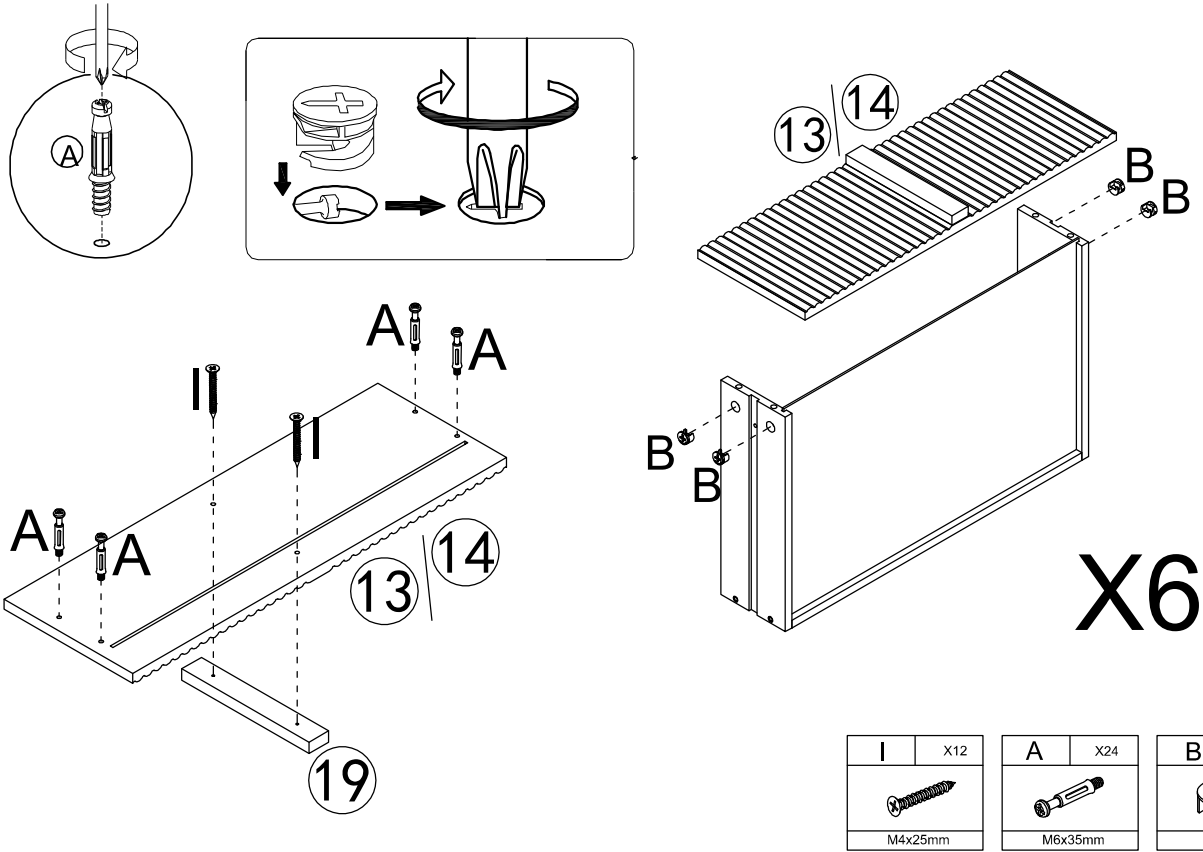

# STEP 20

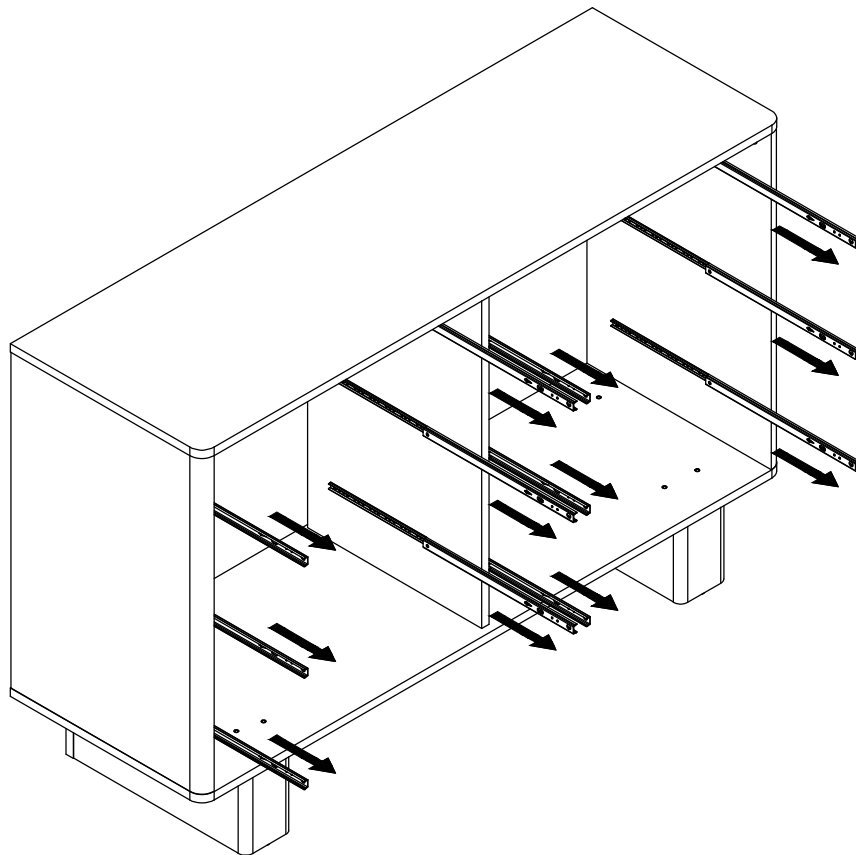

# STEP 21

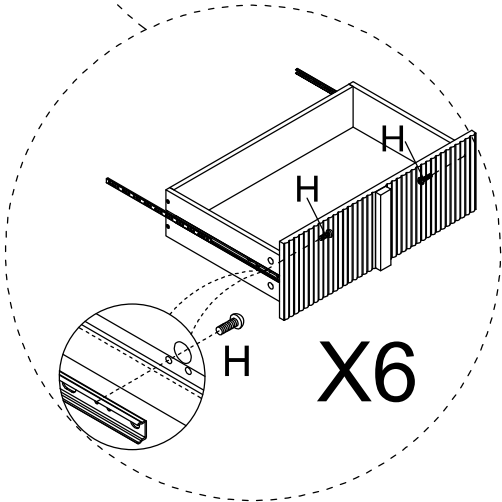
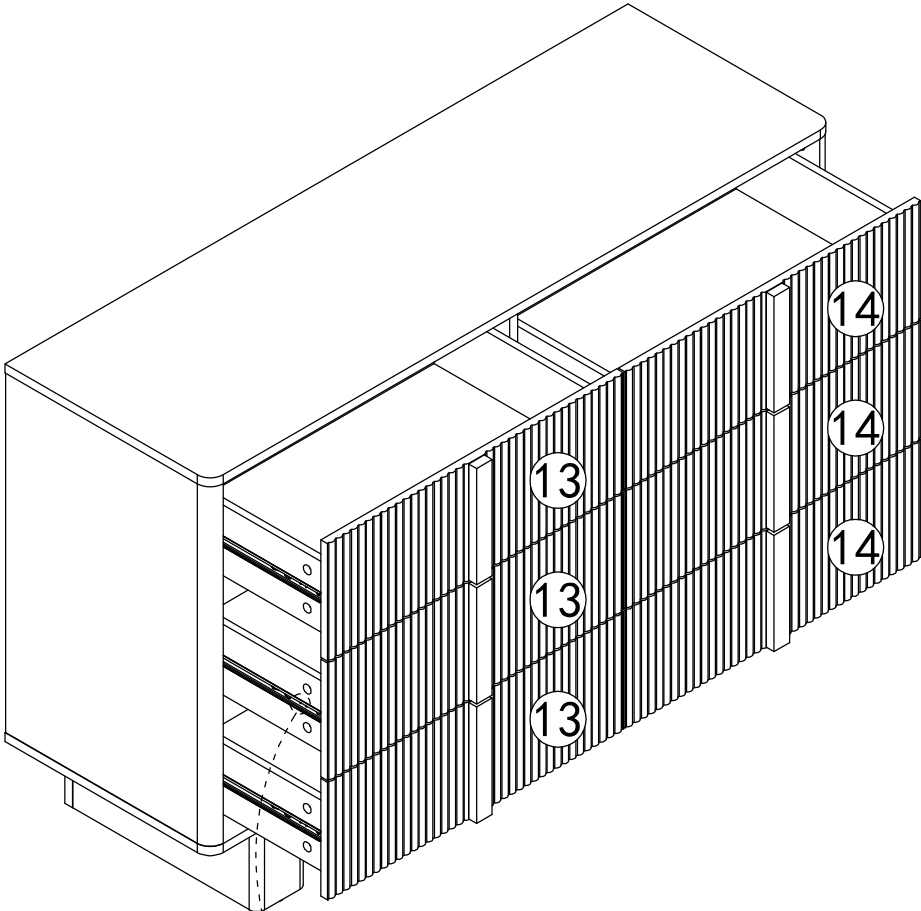

H	X12
	
M4x10mm	

# Finished!

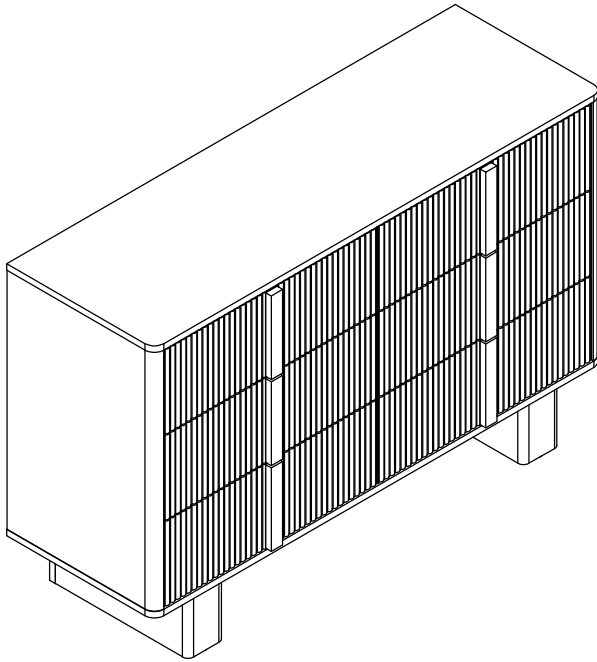

Congratulations, you have made it through the assembly process! We're almost there! ☆

Please perform following checks to ensure assembly is properly done.

- If drawer is misaligned, please check and ensure the screw position is correct as per step 3 & 4.

Move your product carefully, with 2 people lifting it to the preferred location. Clean the product with a dry cloth. You are all set!

Enjoy your fresh and updated living space thanks to the addition of your new product!