

ASSEMBLY INSTRUCTIONS

Space Saver

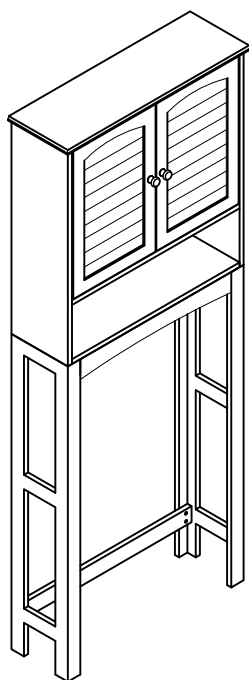

Please provide the following information when contacting for parts or questions: the name of the company you purchased from, the UPS/FedEx tracking number.

ASSEMBLY INSTRUCTIONS-IMPORTANT

Carefully unpack & identify each component before attempting to assemble. Refer to parts list. Please take care when assembling the unit and always set the parts on a clean, soft surface. If you require any assistance with assembly, parts, please call the company you place order with or please email

INSTRUCCIONES PARA ARMAR-IMPORANT:







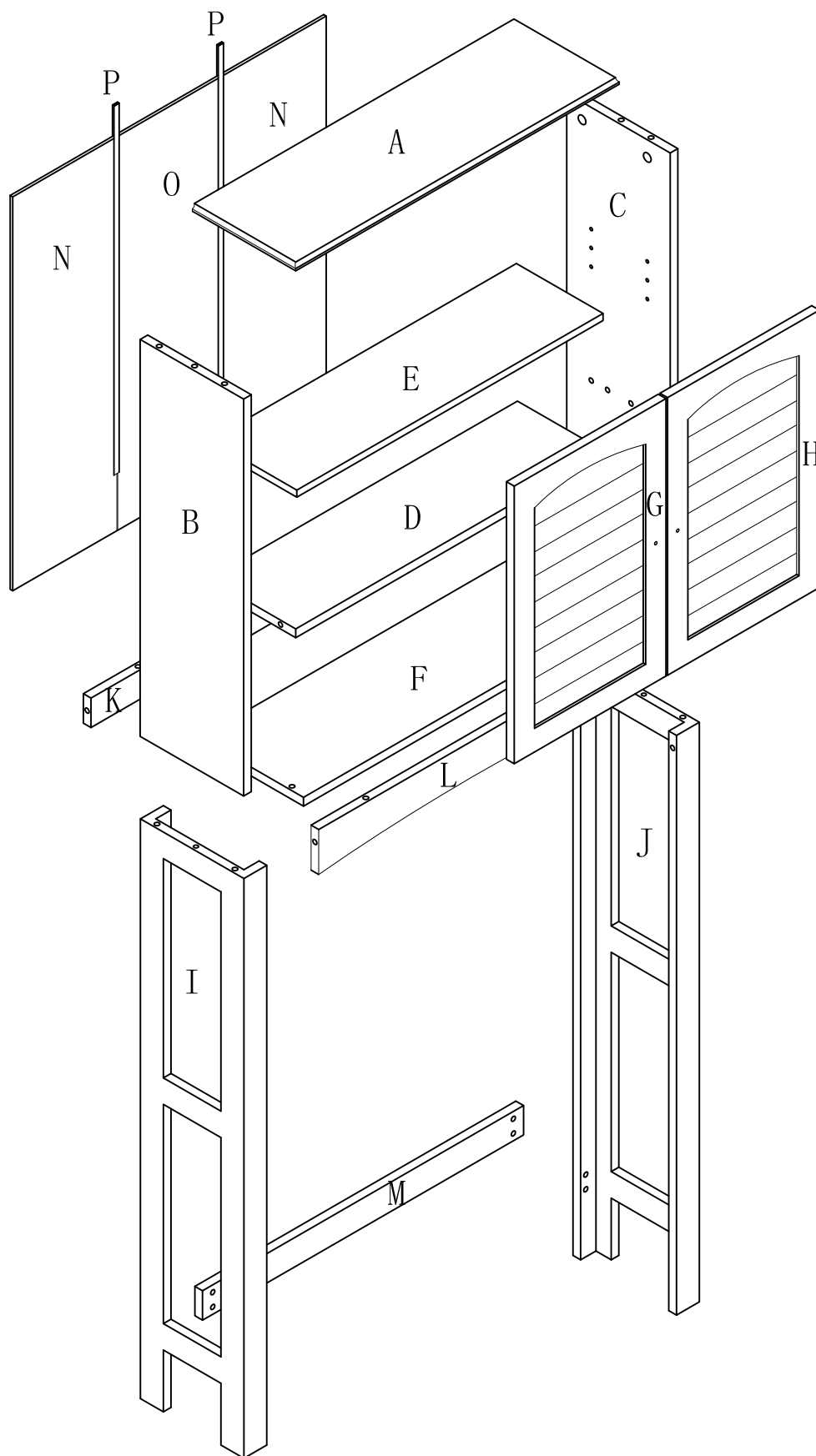









Desempaque cuidadosamente e identifique cada componente antes de tartar de empezar su ensambladura. Verifique la lista de partes. Por favor tenga cuidado cuando arme la unidad y siempre coloque las piezas sobre una superficie plana, suave y limpia. Si necesita ayuda con el armado, envíe un correo electzórico

DIRECTIVES DE MONTAGE-IMPORTANT:











Avant de commencer l' assemblage, déballez délicatement toutes les pièces et repérez-les sur la liste des pièces. Procédez avec soins durant l' assemblage et posez toujours les pièces sur une surface proper, douce et lisse. sie vouo plait e-mail

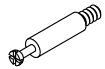

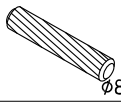
COMPONENTS

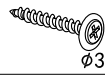
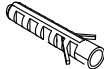
PART	FIGURE	DESCRIPTION	QTY	PART	FIGURE	DESCRIPTION	QTY
A		TOP PANEL	1PC	I		BOTTOM LEFT SIDE FRAME	1PC
B		UPPER LEFT SIDE PANEL	1PC	J		BOTTOM RIGHT SIDE FRAME	1PC
C		UPPER RIGHT SIDE PANEL	1PC	K		UPPER BACK RAIL	1PC
D		FIXED SHELF	1PC	L		UPPER FRONT RAIL	1PC
E		ADJUSTABLE SHELF	1PC	M		BOTTOM RAIL	1PC
F		BOTTOM PANEL	1PC	N		BACK PANEL	2PCS
G		LEFT DOOR	1PC	O		BACK PANEL	1PC
H		RIGHT DOOR	1PC	P		PLASTIC BAR	2PCS

HARDWARE & TOOLS

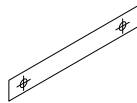
PART	FIGURE	DESCRIPTION	QTY	PART	FIGURE	DESCRIPTION	QTY
1	 $\phi 15 \times 12$	CAM LOCK	16PCS	9		SHELF PIN	4PCS
2		CAM BOLT	16PCS	10		SHORT BOLT	4PCS
3	 $\phi 8 \times 30$	WOODEN DOWEL	14PCS	11	 $\phi 3 \times 12$	SCREW	8PCS
4	 $\phi 3 \times 12$ D=7	SCREW	20PCS	12		ANCHOR	2PCS
5		BOLT	2PCS	14	 $\phi 4 \times 35$	SCREW	2PCS
6		LONG BOLT	2PCS	15		DOOR KNOB	2PCS
		TEMPLATE PAPER					

TOOL NEEDED:



**PHILIPS SCREWDRIVER REQUIRED
- NOT INCLUDED**

SUGGESTION:



TWO PEOPLE FOR ASSEMBLING





WARNINGS:

1. DO NOT LET ANY SHARP OBJECTS TOUCH OR RUB THE SURFACE OF THE PRODUCT.
2. WHEN ASSEMBLING, DO NOT LET CHILDREN PLAY AROUND THE WORKING AREA.
3. PLEASE CONFIRM ALL PARTS ARE CORRECT BEFORE STARTING THE ASSEMBLY PROCESS.
4. DO NOT TIGHTEN ALL BOLTS AND SCREWS COMPLETELY UNTIL THE ENTIRE UNIT HAS BEEN ASSEMBLED AND SET UP.

1

1
4 PCS  $\phi 15 \times 12$

2
4 PCS 

3
2 PCS  $\phi 8 \times 30$

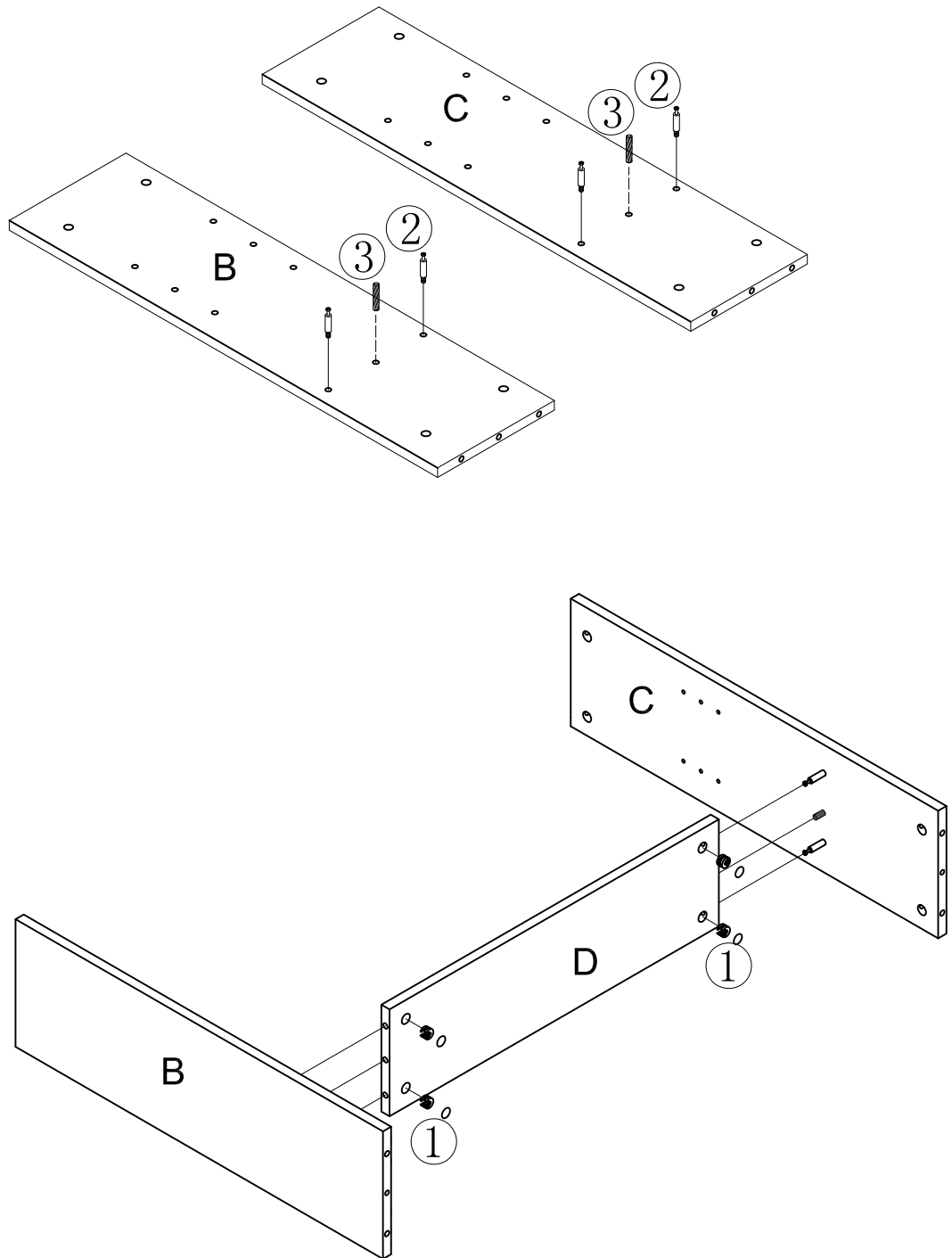

STEP 1:

1. Screw cambolts (2) into panel B & C and insert dowels (3).
2. Attach panel D to panels B & C and secure with camlocks (1).

2

1
4 PCS $\phi 15*12$

2
8 PCS

3
2 PCS $\phi 8*30$

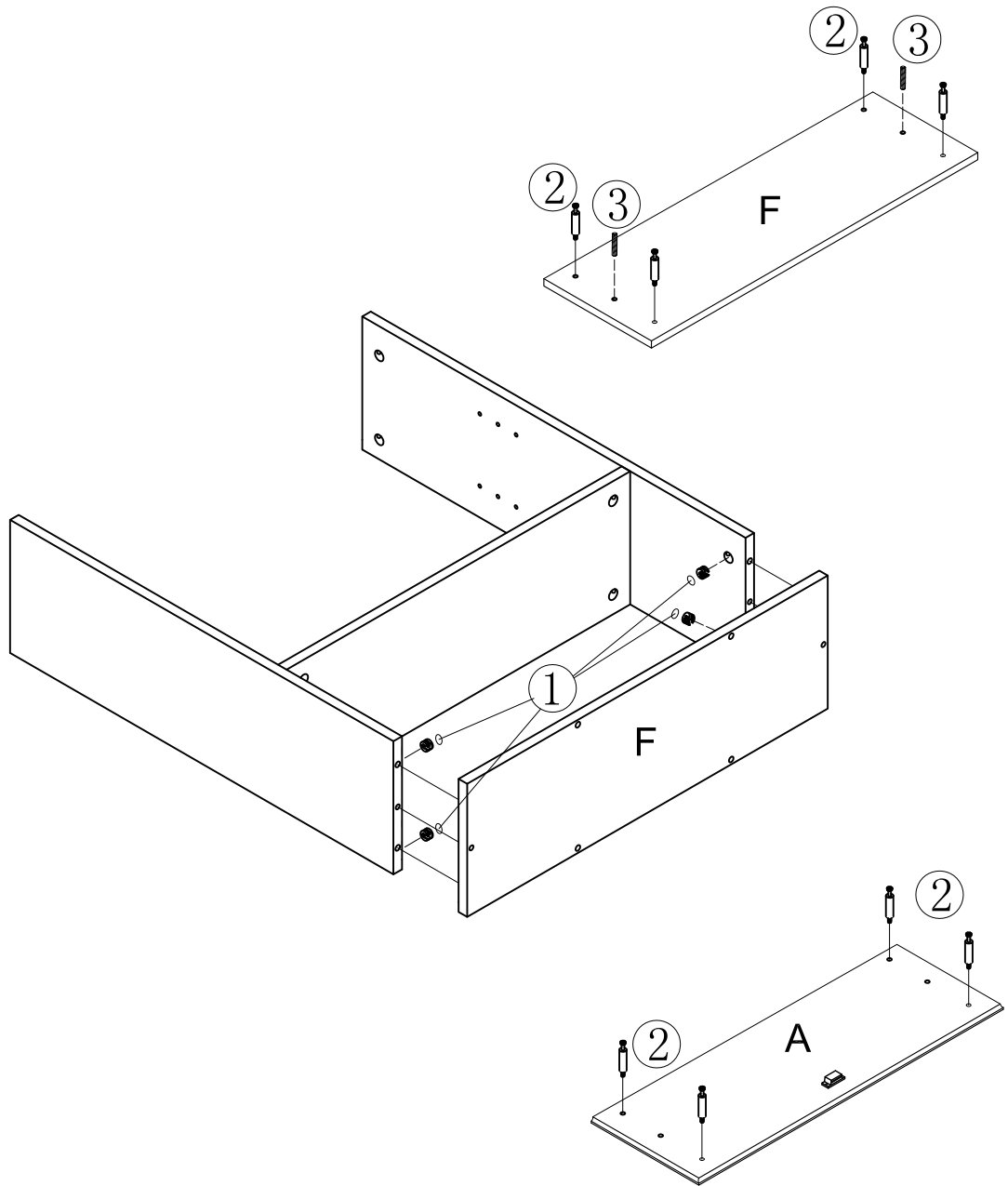

STEP 2:

1. Screw cambolts (2) and insert dowels (3) into panel F.
2. Attach panel F to panel B & C with securing camlocks (1).
3. Screw cambolts (2) into panel A.

3

1

4 PCS $\phi 15 \times 12$

3

2 PCS

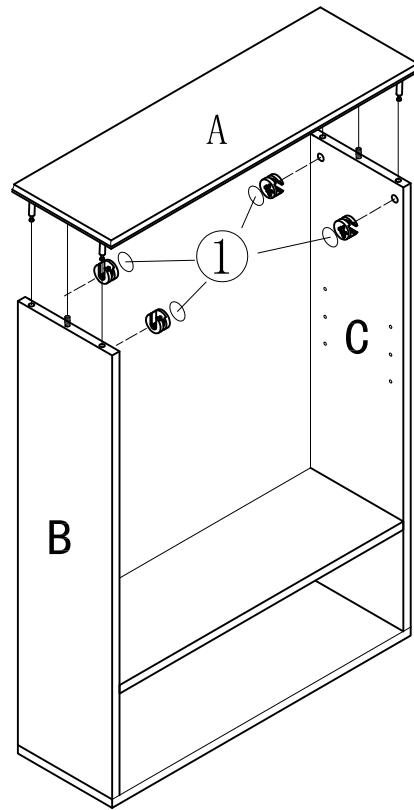
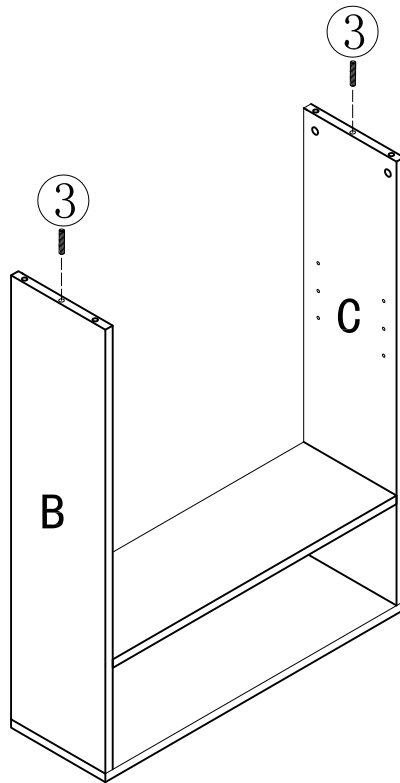

STEP 3:

- 1. Insert dowels (3) to the tops of B & C.**
- 2. Attach panel A to panel B & C with securing camlocks (1).**

4

4



20 PCS $\phi 3*12$ D=7

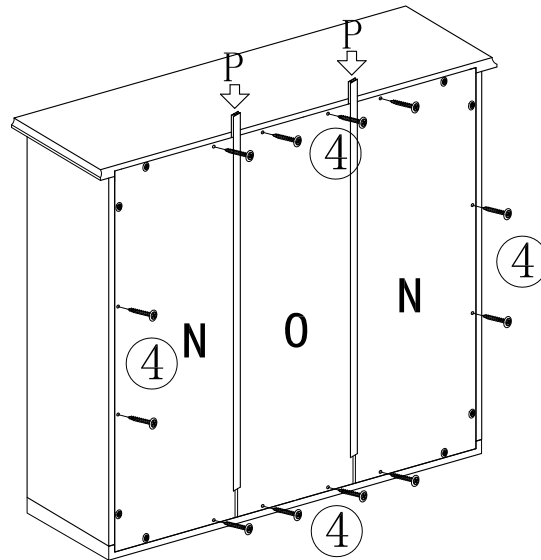
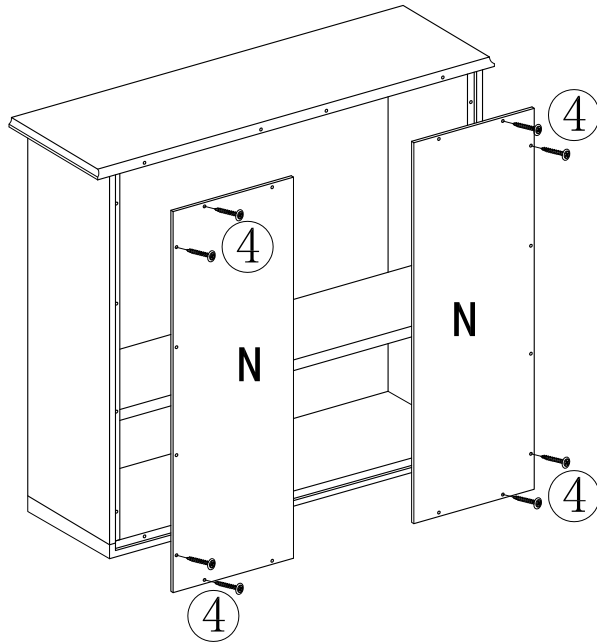

STEP 4:

- 1. Attach panels N to the back of cabinet and secure the four corners with screws (4).**
- 2. Attach panel O between the two panels N and insert plastic bar P with securing screws (4).**

5

5



2 PCS

11



8 PCS $\phi 3*12$

15



2 PCS

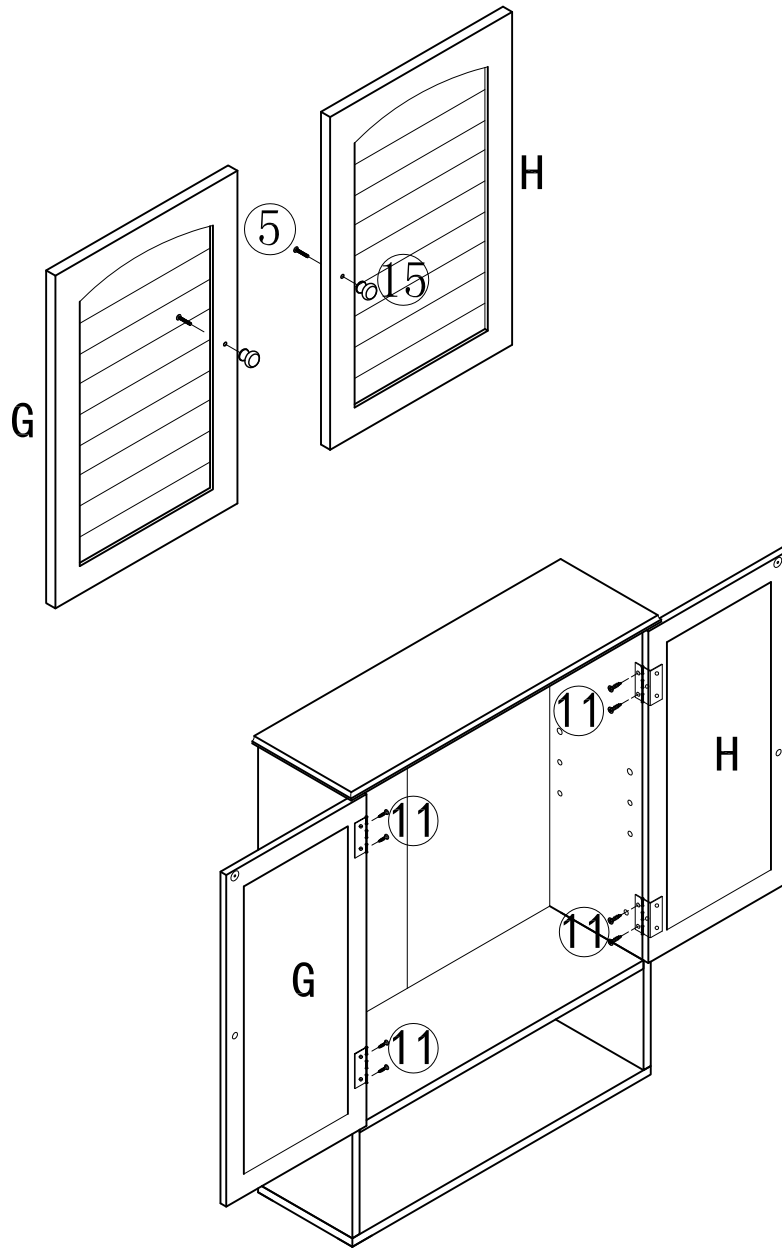

STEP 5:

- 1. Attach knobs (15) to doors G & H with bolts (5).**
- 2. Attach doors G & H to panels B & C with screws (11).**

6

1

4 PCS  $\varnothing 15 \times 12$

2

4 PCS 

3

4 PCS 

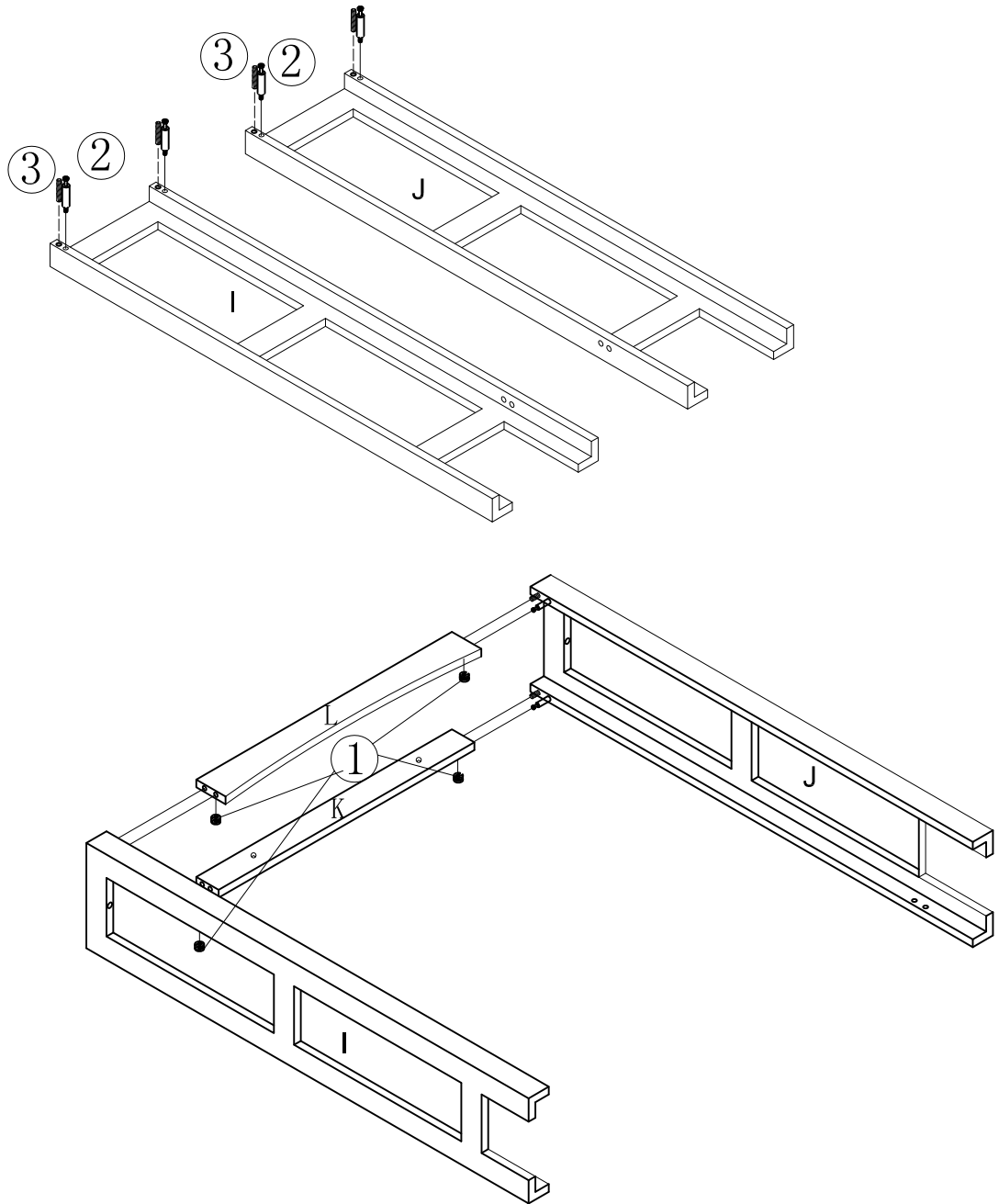

STEP 6:

1. Screw cambolts (2) and insert dowels (3) into parts I & J.
2. Attach rails K & L to parts I & J with securing camlocks (1).

7

3



4 PCS

10



4 PCS

6



2 PCS

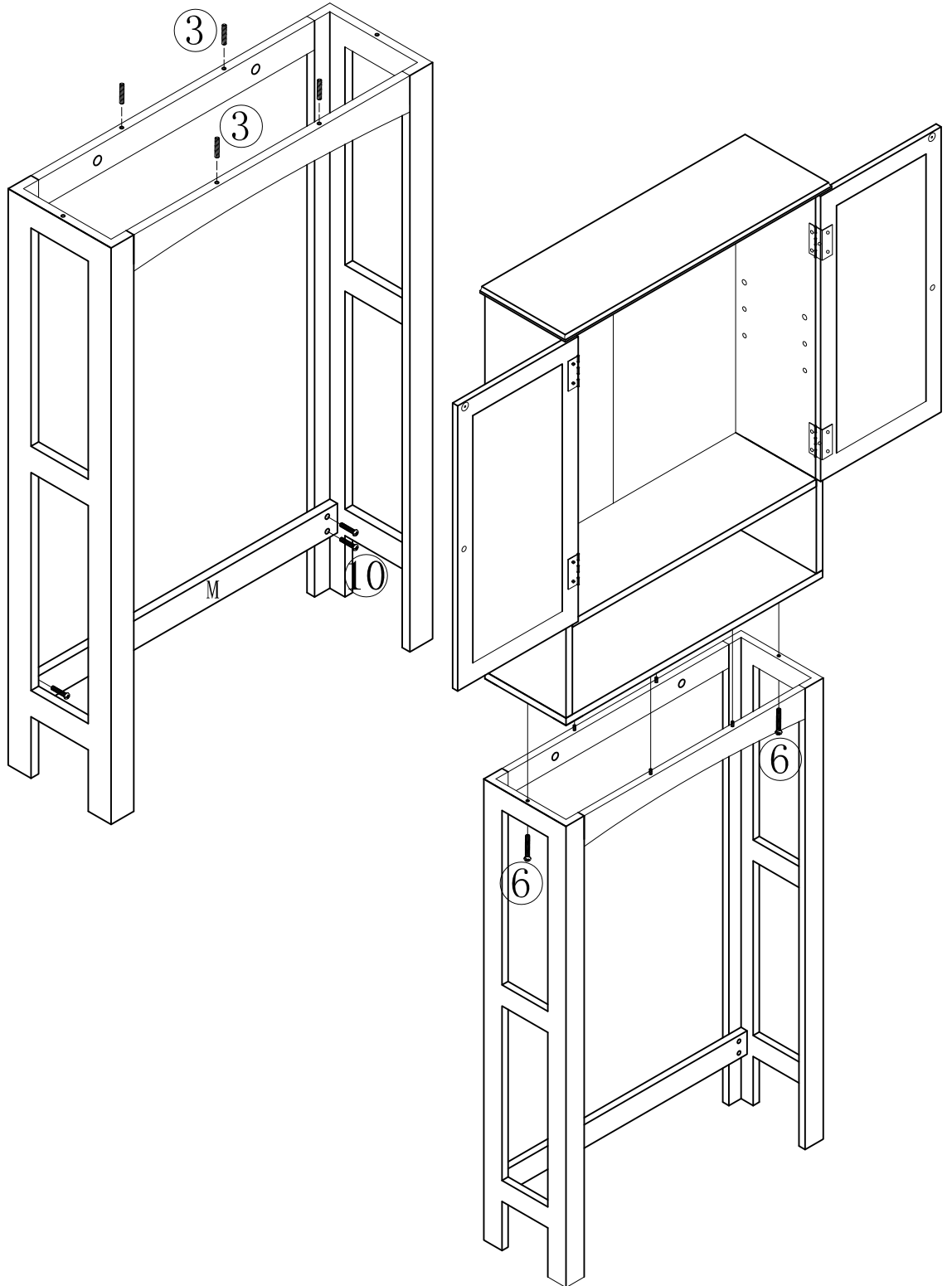

STEP 7:

1. Insert dowels (3) to the tops of K & L.
2. Attach rail M to parts I & J with securing bolts (10).
3. Rest the top of the space saver on bottom frame and secure with bolts (6).

8

9



4 PCS

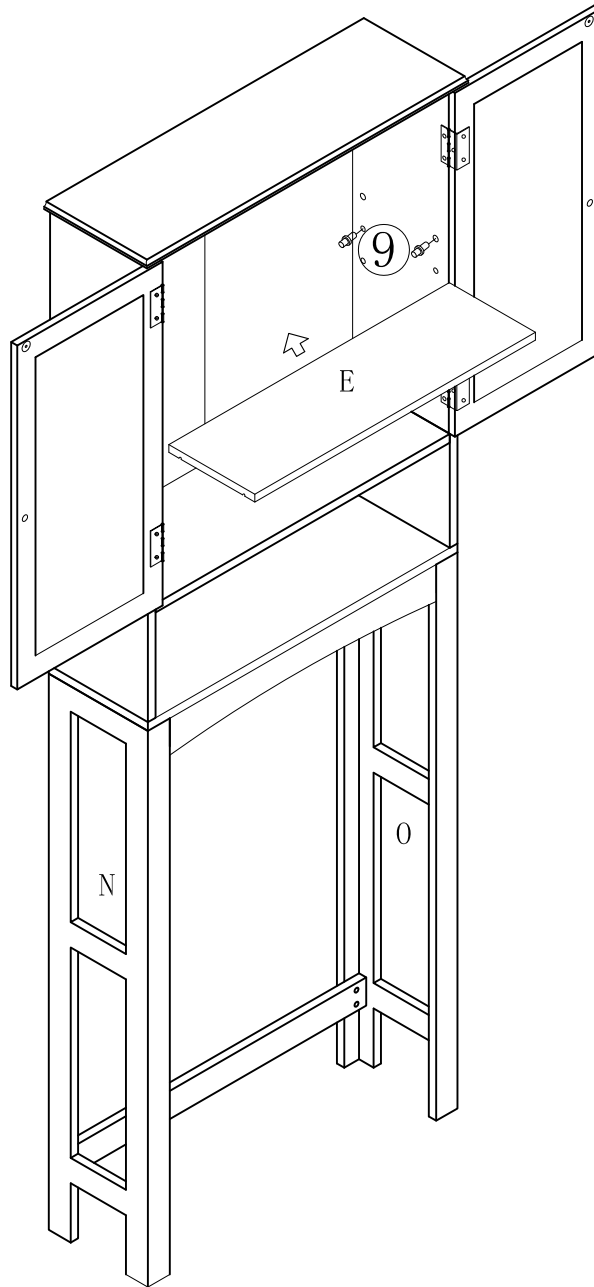

STEP 8:

1. Insert shelf pins (9) and rest adjustable shelf E on the shelf pins.

9

14



2 PCS $\phi 4*35$

12



2 PCS

