

# ASSEMBLY INSTRUCTIONS

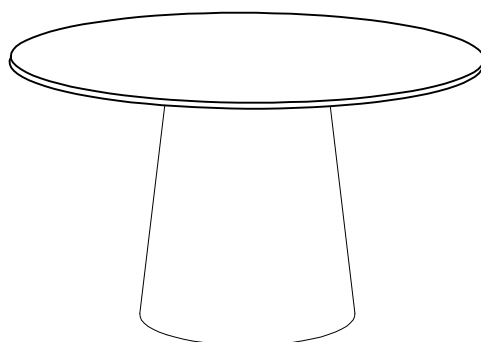

→ Top panel



→ Bridge panel

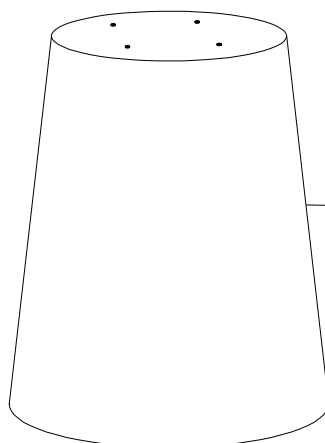



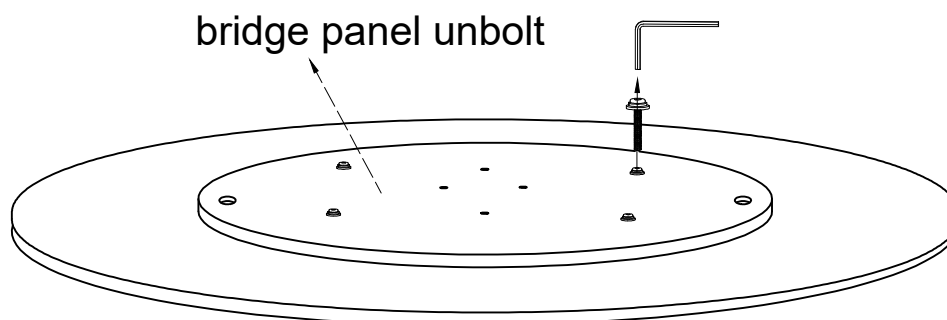

→ Pillar post

## Step 1



## HARDWARE LIST

|   |   |                            |      |
|---|---|----------------------------|------|
| A |  | Bolt (Ø5/16"*1-1/4")       | 4pcs |
| B |  | Lock Washer (Ø5/16")       | 4pcs |
| C |  | Flat Washer (Ø5/16"*Ø3/4") | 4pcs |
| D |  | Allen Wrench (5mm)         | 1pc  |

Step 2

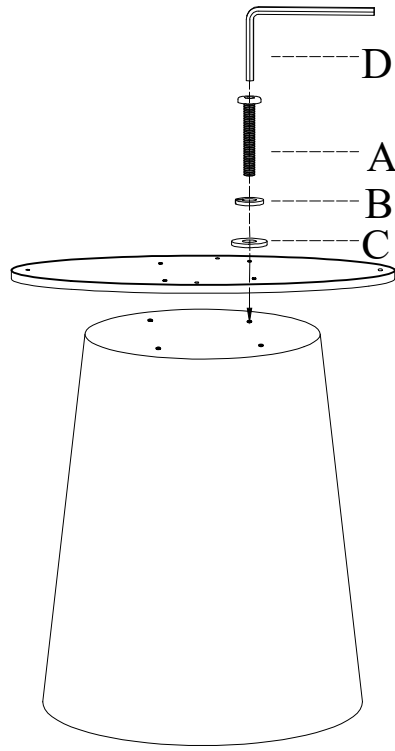

Step 3

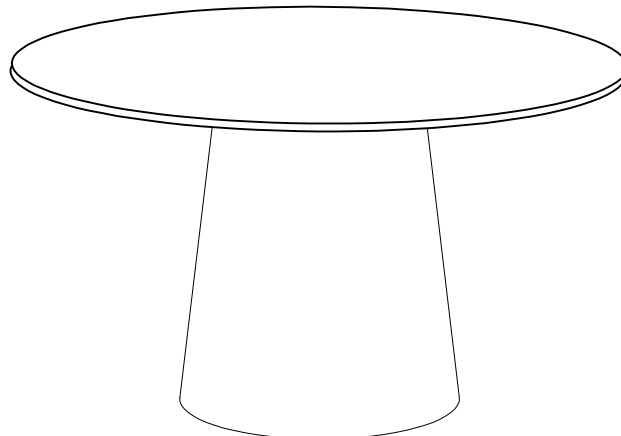
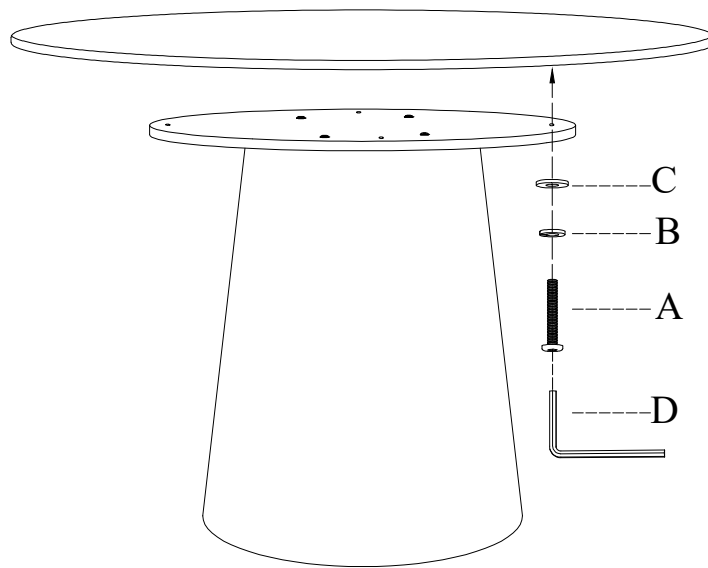

OK