

THANKS FOR WATCHING

Your feedback is invaluable to us and we would love to hear about your experience. Please take the time to leave us a review.

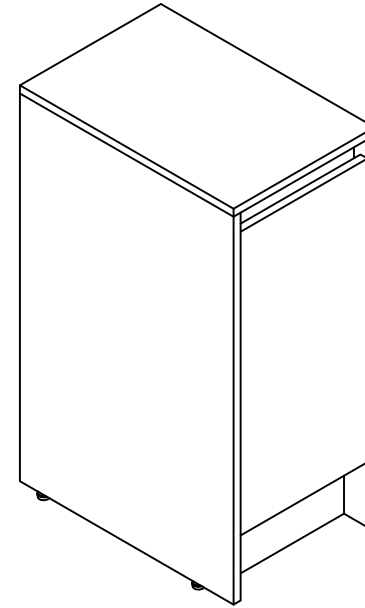













Thank you for shopping with us!

We encourage you to take a few minutes to go through this booklet. It contains important information on installation and care tips to keep your furniture looking as good as new.

Item NO.:SC 00312

Hardware

NO.	Draw	QTY	NO.	Draw	QTY
A	 Screws Ø4 x 14 mm	12	G	 Screws for fix on the wall	2
B	 Two-in-one connector	24	H	 Wall hanging screw decorative cover	2
C	 Two-in-one connector	24	I	 Adjustable feet	4
D	 Wood plug	6	J	 Movable laminate support	4
E	 Plastic anchor(Ø10mm)	2	K	 Anti-collision gasket	2
F	 Hinges (Internal hiding)	2	L	 Screwdriver	1

Recommended tools

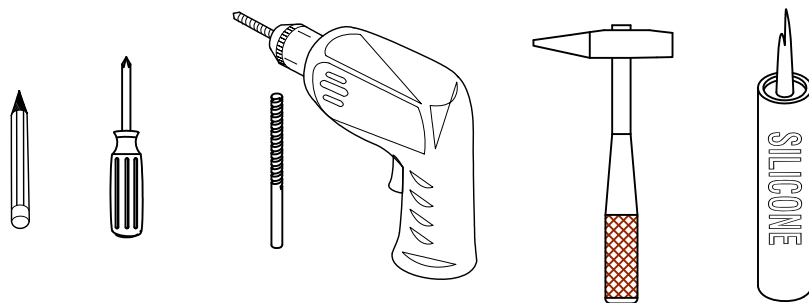

Dimensions

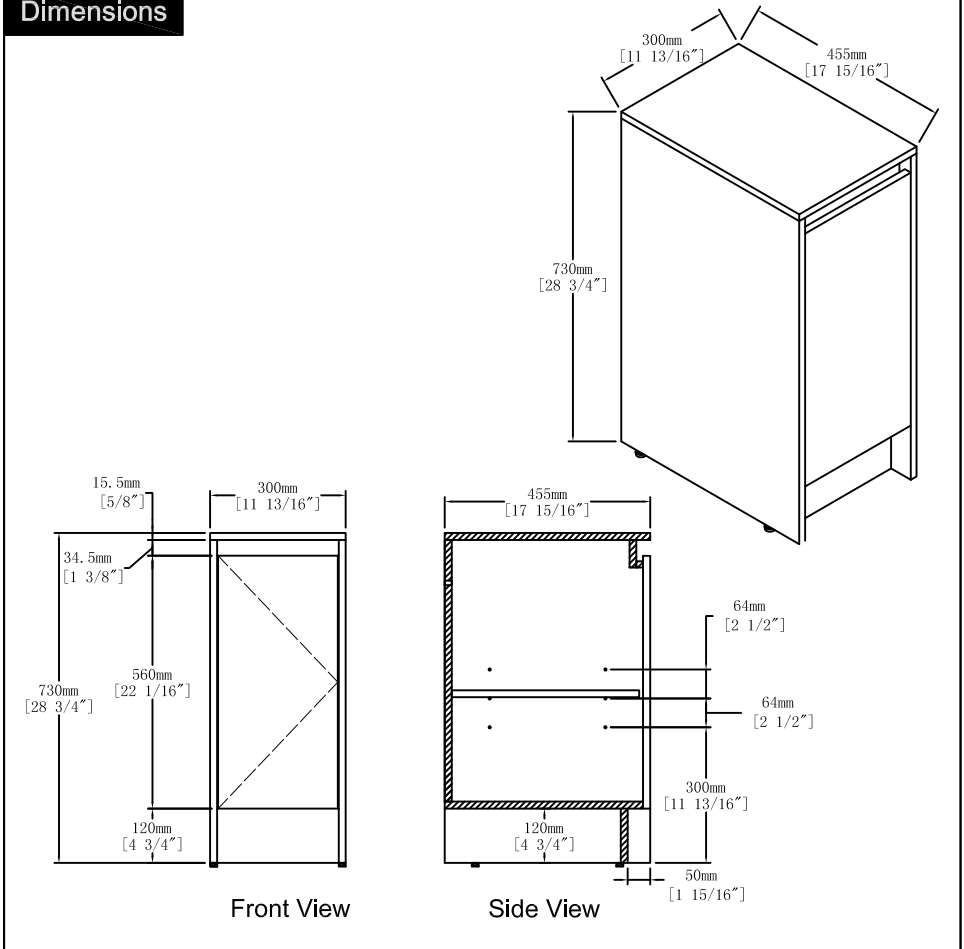

CARE CLEANING AND MAINTENANCE

1. Dust regularly with a soft , dry cloth.
2. Avoid the use of all chemicals household cleaners, abrasives, or cleaners that contain lemon, vinegar, or other acids that may damage the finish.
3. Excessive exposure to sunlight and extreme changes in temperature and moisture can damage wood furniture.
4. Do not place hot appliances, such as curling irons and hot hair dryers directly on the countertop. Wipe spills immediately.

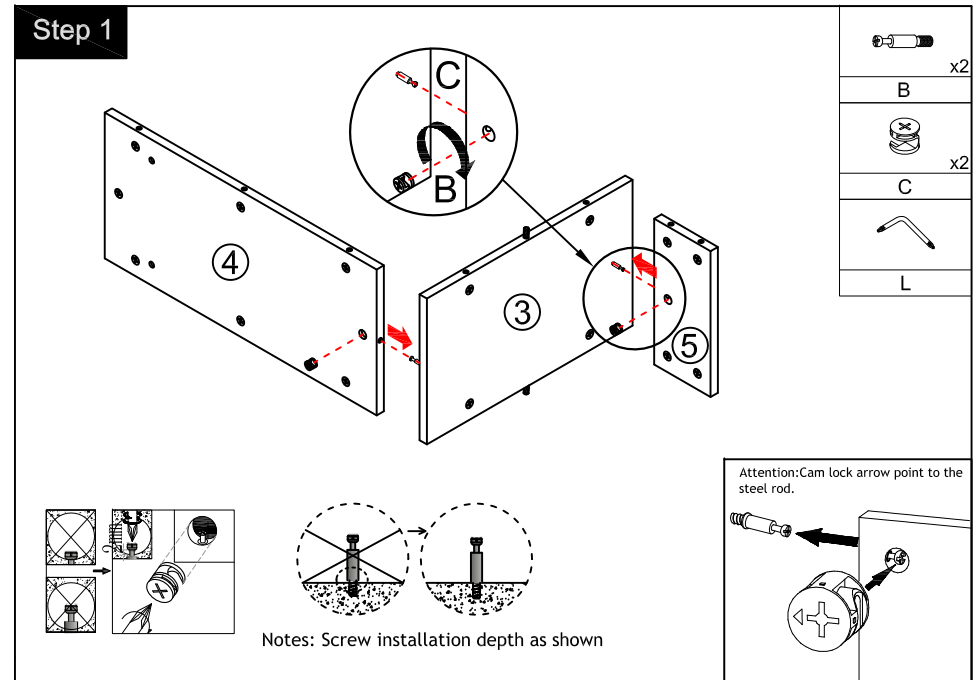
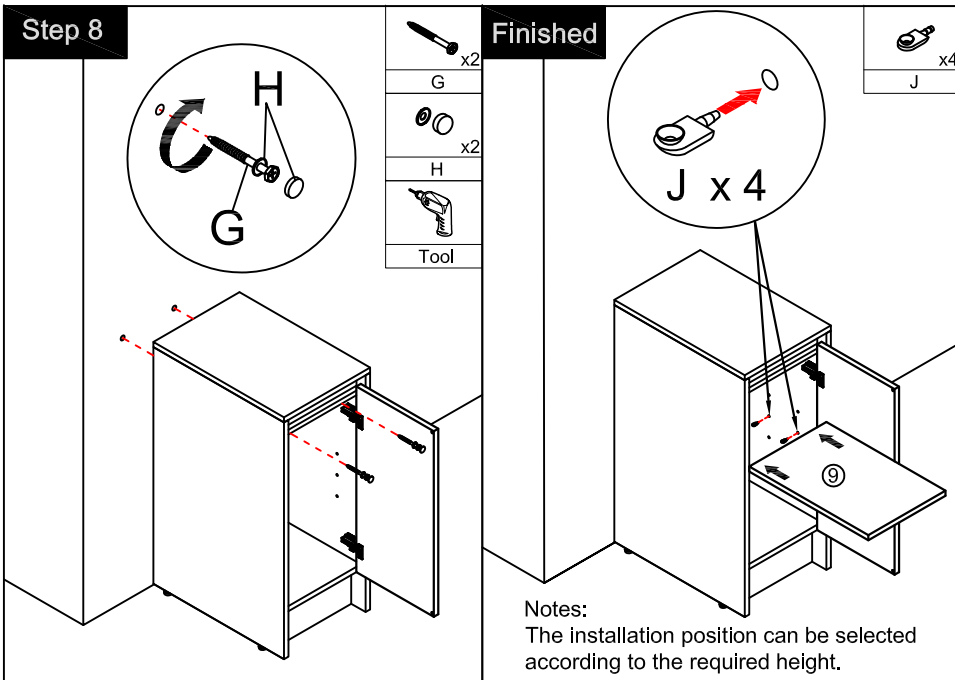
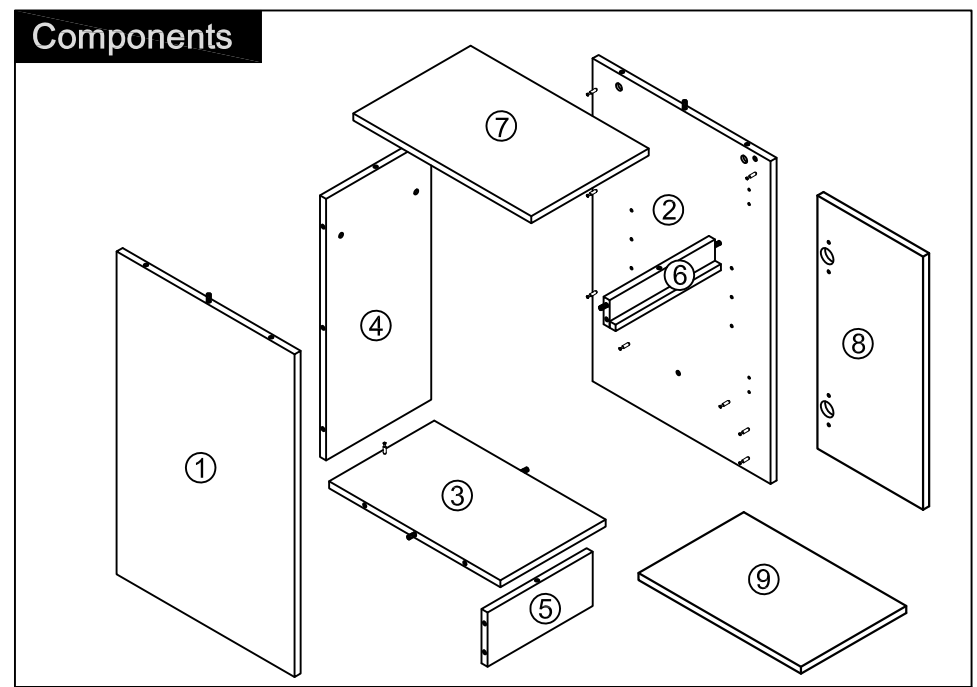
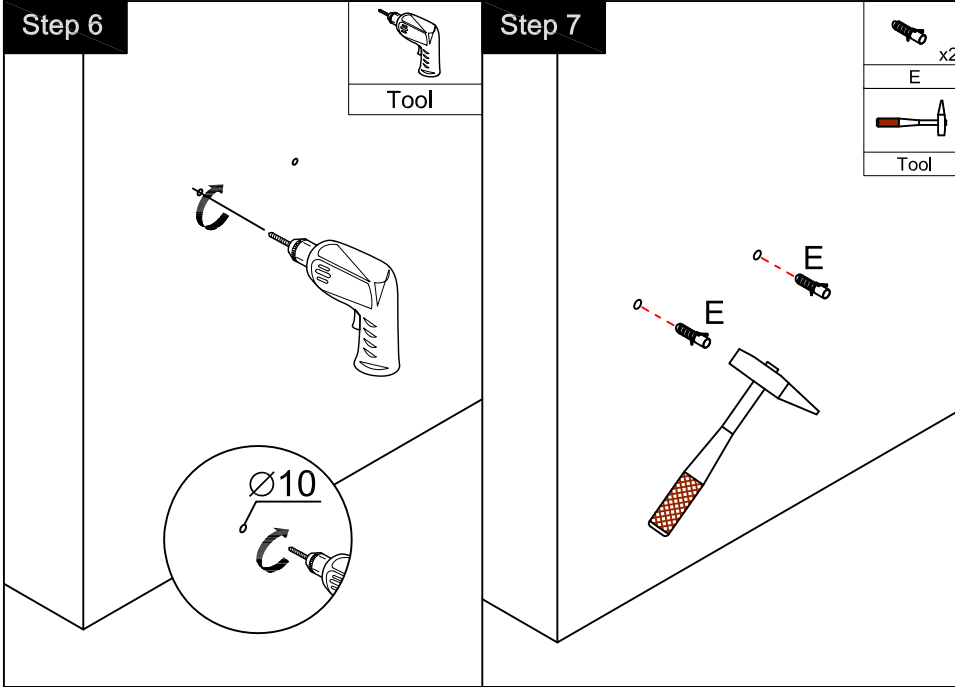

Step 2

Note: The D parts are used for these two holes

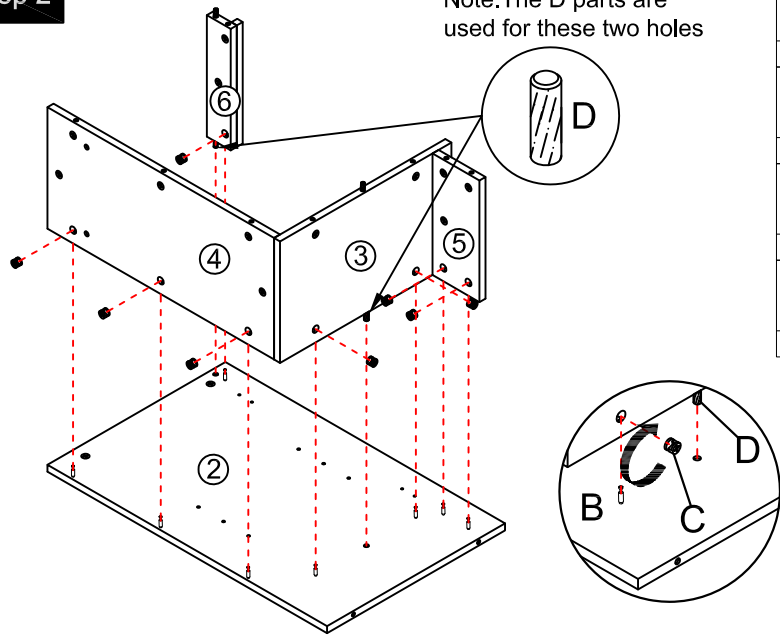

	x8
B	
	x8
C	
	x2
D	
L	

Step 4

Note: The D parts are used for these two holes

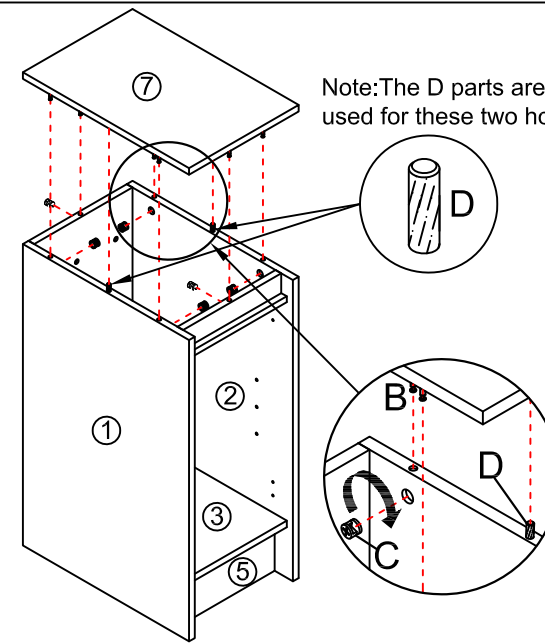

	x6
B	
	x6
C	
	x2
D	
L	

Step 3

Note: The D parts are used for these two holes

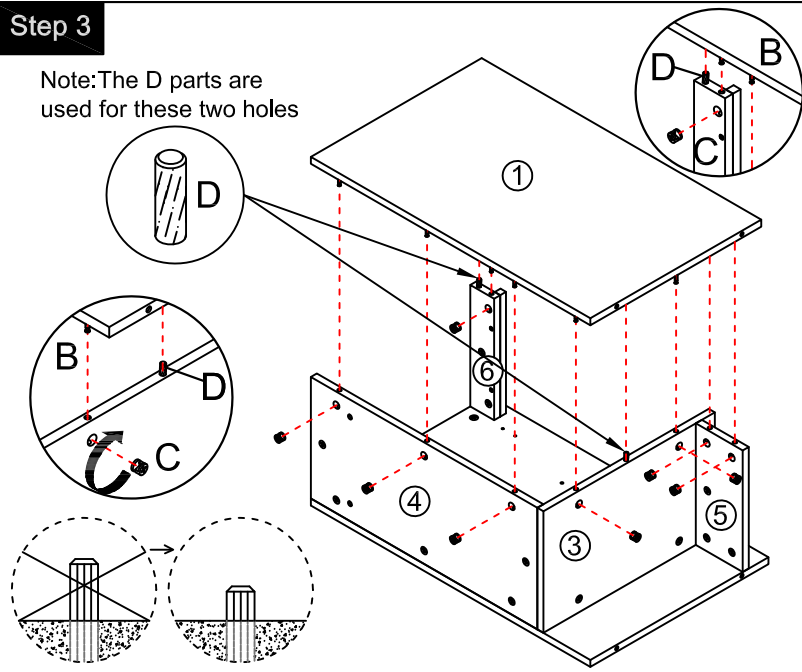

	x8
B	
	x8
C	
	x2
D	
L	

Step 5

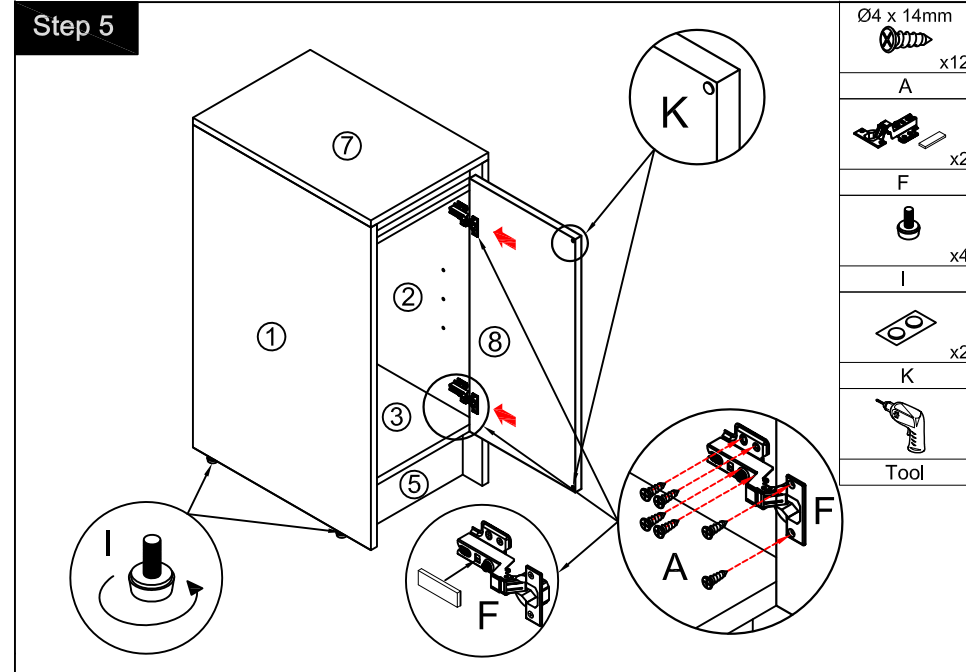

$\text{Ø}4 \times 14\text{mm}$	
	x12
A	
	x2
F	
	x4
I	
	x2
K	
Tool	