

# Assembly Instruction

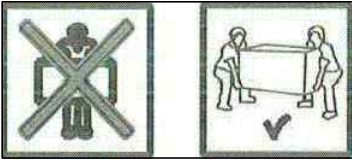
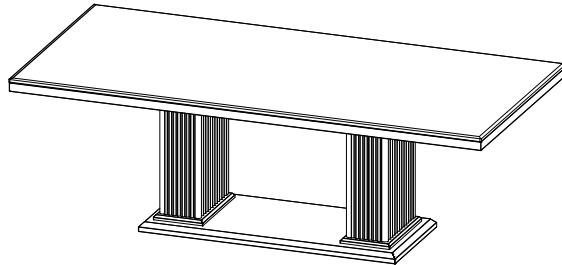

ASSEMBLY TIME PER UNIT:

20MINUTES

## PARTS IDENTIFICATION

**A Base**

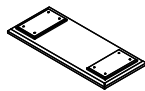

**1PC**

**B Top**

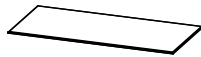

**1PC**

**C Frame**

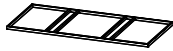

**1PC**

**D Box**



**2PCS**

## HARDWARE LIST

NO.	SIZE	DIAGRAM	QTY
1	Allen wrench		1
2	Allen wrench		1
3	Bolts M8x70		8
4	Bolts M8x50		8
5	Flat washer		16
6			8

### STEP 1

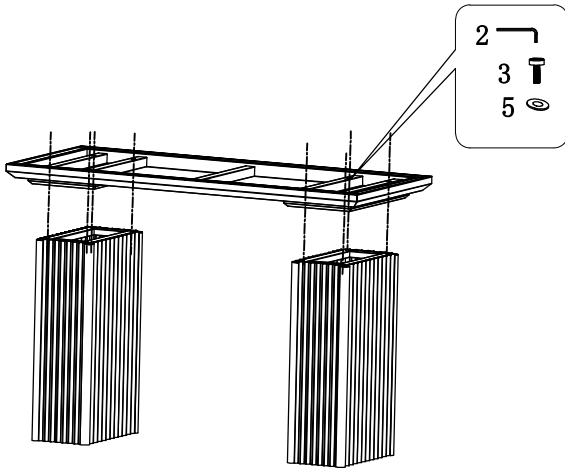

### STEP 2

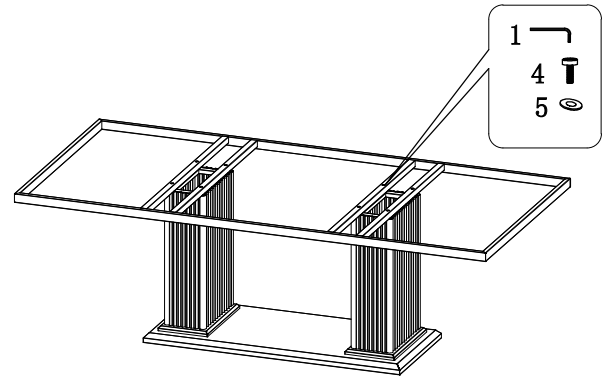

### STEP 3

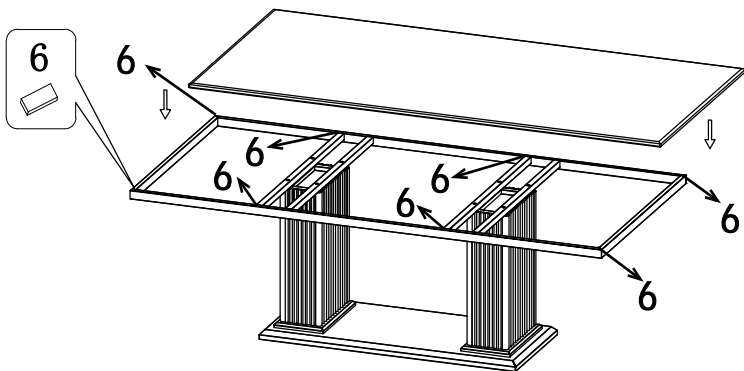

take off the protection for "6"  
then stick to frame

### COMPLETED

