

Assembly Instructions

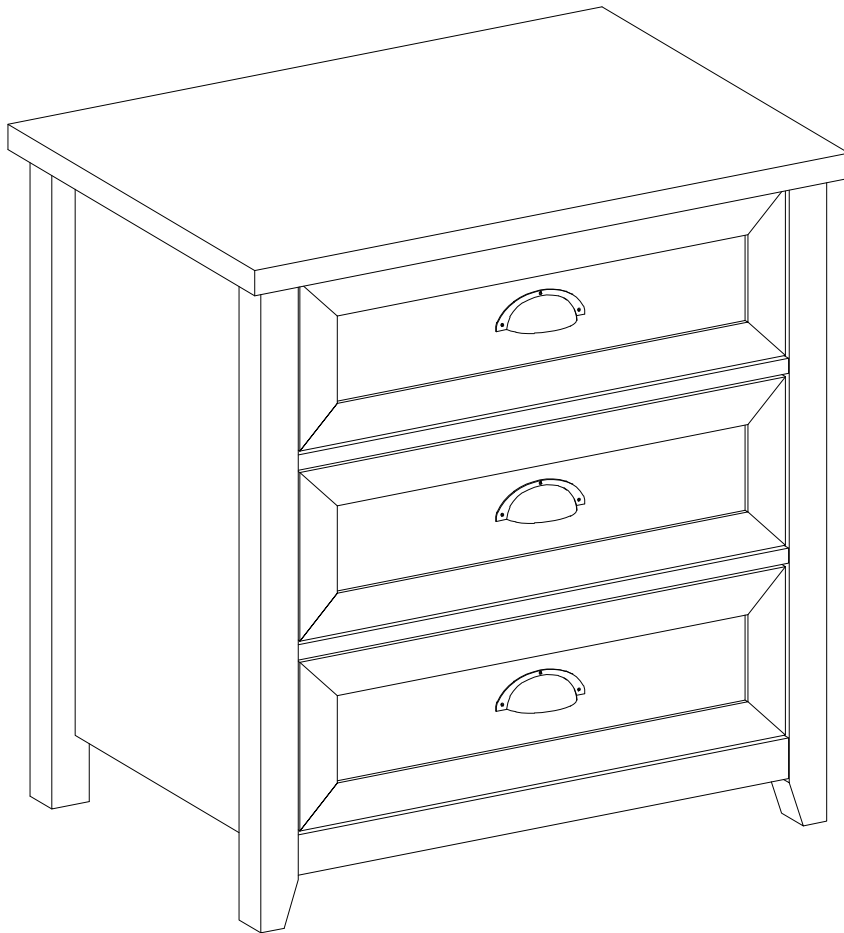

General Assembly Guidelines

- I. Ensure that all parts and hardware are available before beginning assembly.
- II. Follow each step carefully to ensure the proper assembly of this product.
- III. Two people are recommended for ease in the assembly of this product.
- IV. The three main types of hardware used to assemble this product are: wood dowels, screws and bolts.
- V. The provided glue is to secure wood dowels in place. When first inserting dowels, locate the appropriate hole for the dowel, place a small amount of glue in the hole and insert the dowel. Wipe away excess glue immediately.

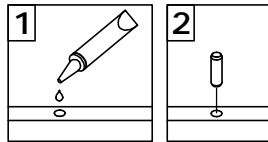

In future assembly steps when dowels are necessary to attach assembly parts together, place a small amount of glue on the end of the dowel before attaching parts together. Wipe away excess glue immediately.

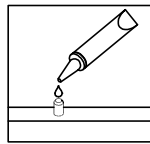

- VI. A Phillips head screwdriver is required for the assembly of this product .

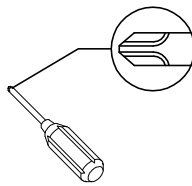

- VII. Power tools should not be used to assemble this product.

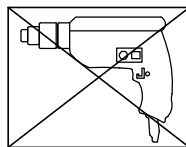





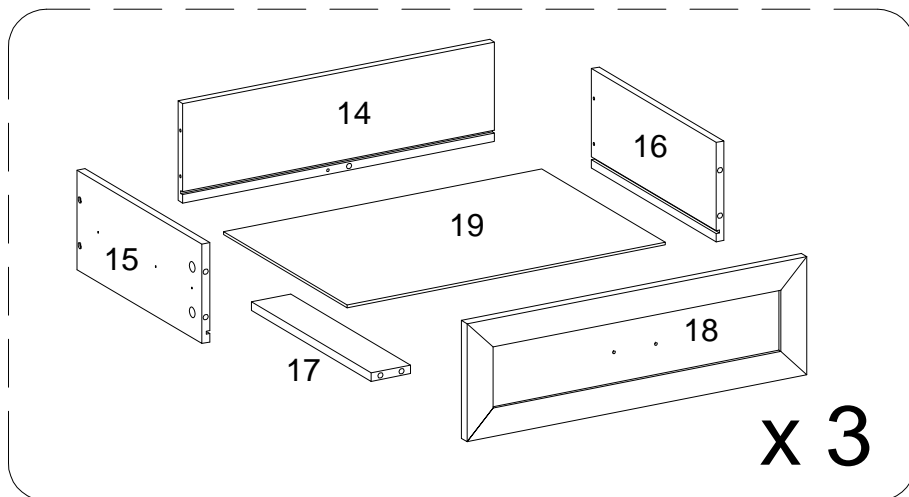
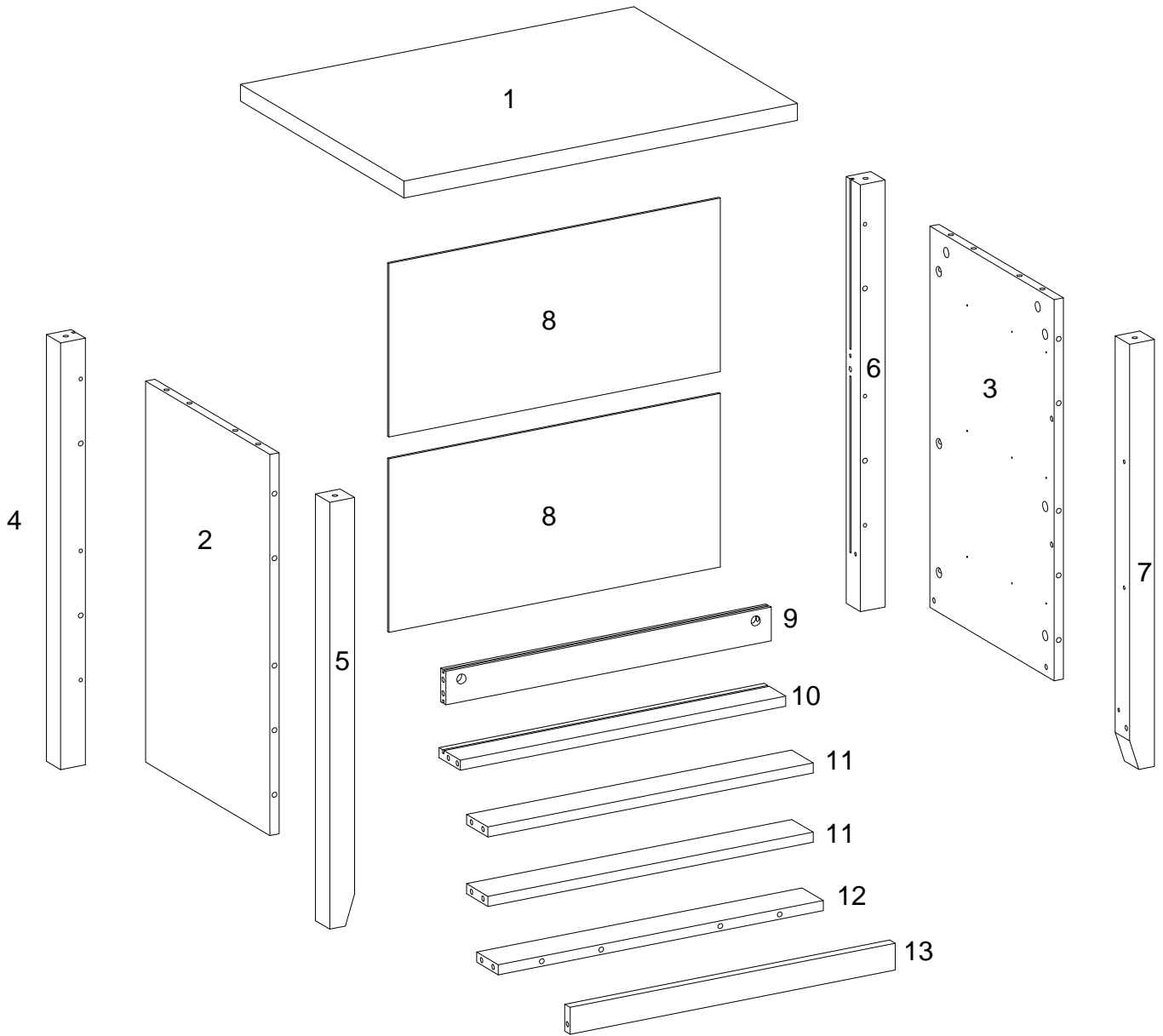



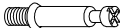

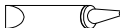

- VIII. Drill may be needed for securing product to wall.

Parts List



Hardware List

A		Ø8x30mm	Wooden dowel	30 pcs
B		Ø6x35mm	Cam bolt	43 pcs
C		Ø15x11mm	Cam lock	28 pcs
D		Ø15x9mm	Cam lock	15 pcs
E		Ø30mm	Sticker	43 pcs
F			Plastic wedge	6 pcs
G		Ø3x17mm	Screw	6 pcs
H			Glue tube	2 pcs
J		Ø4x38mm	Screw	15 pcs
K		Ø3x12mm	Screw	36 pcs
L			Handle	3 pcs
M		Ø4x10mm	Handle Bolt	6 pcs
N		Ø6x30mm	Wooden dowel	6 pcs
P		12"	Drawer slider	3 Sets

* Note: This piece comes preassembled for shipping purposes and must be disassembled to complete the desk assembly.

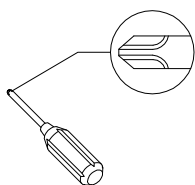

Philips head screwdriver required for assembly
(not included)

*The hardware quantities listed above are required for proper assembly.
Some extra hardware may also have been included.*

Step 1

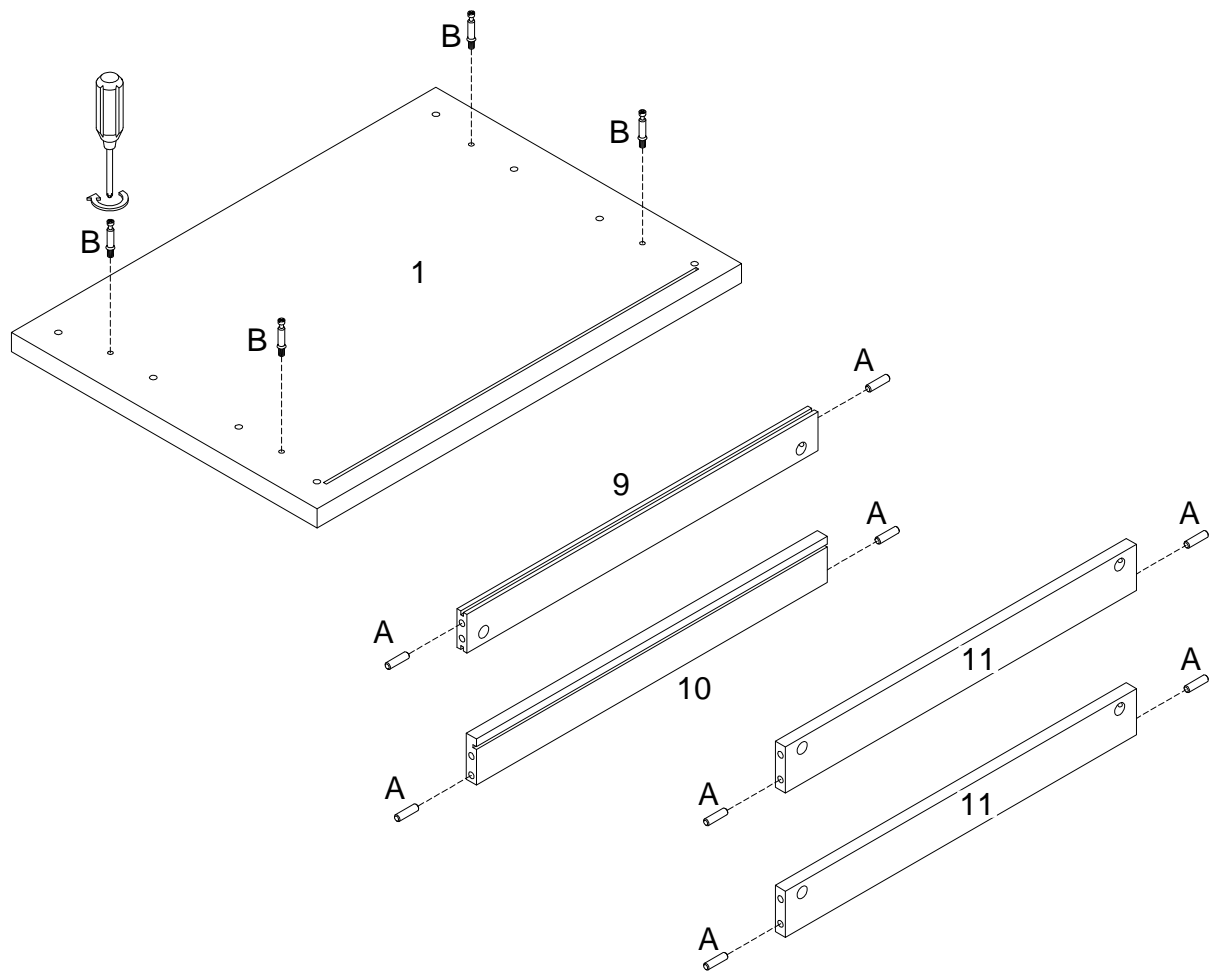

Insert wooden dowel (A) into parts (9,10,11) , then secure cam bolt (B) into part (1) with Philips head screwdriver as per diagram.

Step 2

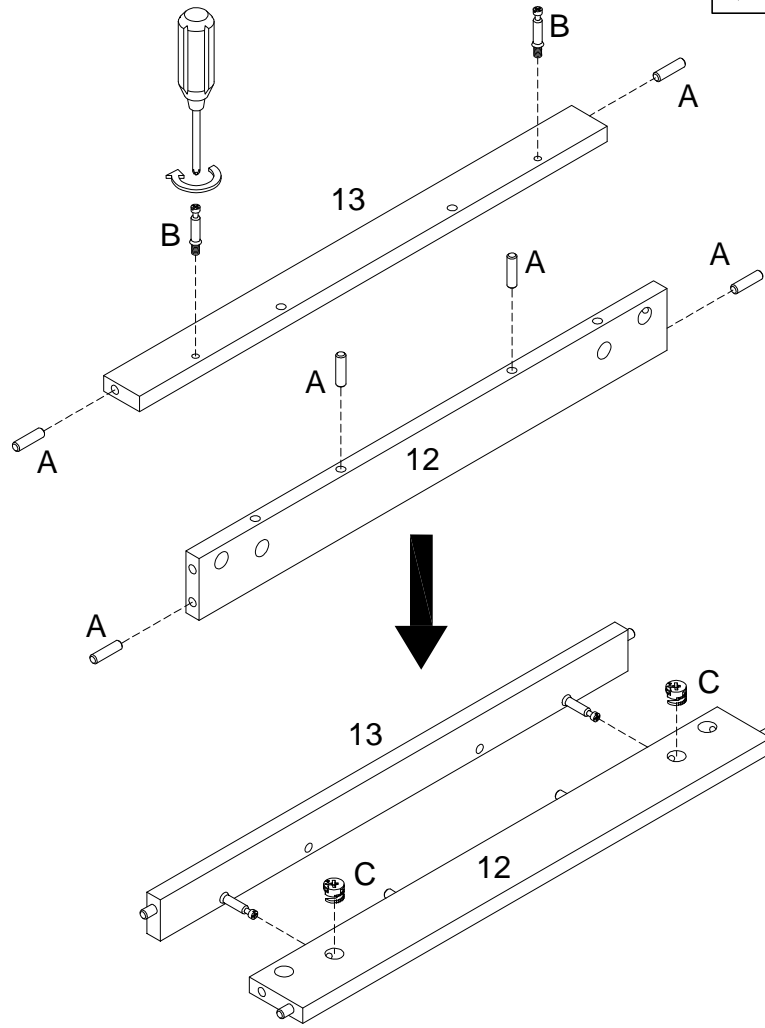
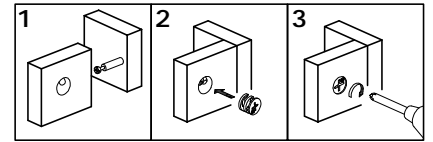

Insert wooden dowel (A) into parts (12,13) , then secure cam bolt (B) into part (13) ,then using cam lock (C) secure part (13) to part (12) with Philips head screwdriver as per diagram.

Step 3

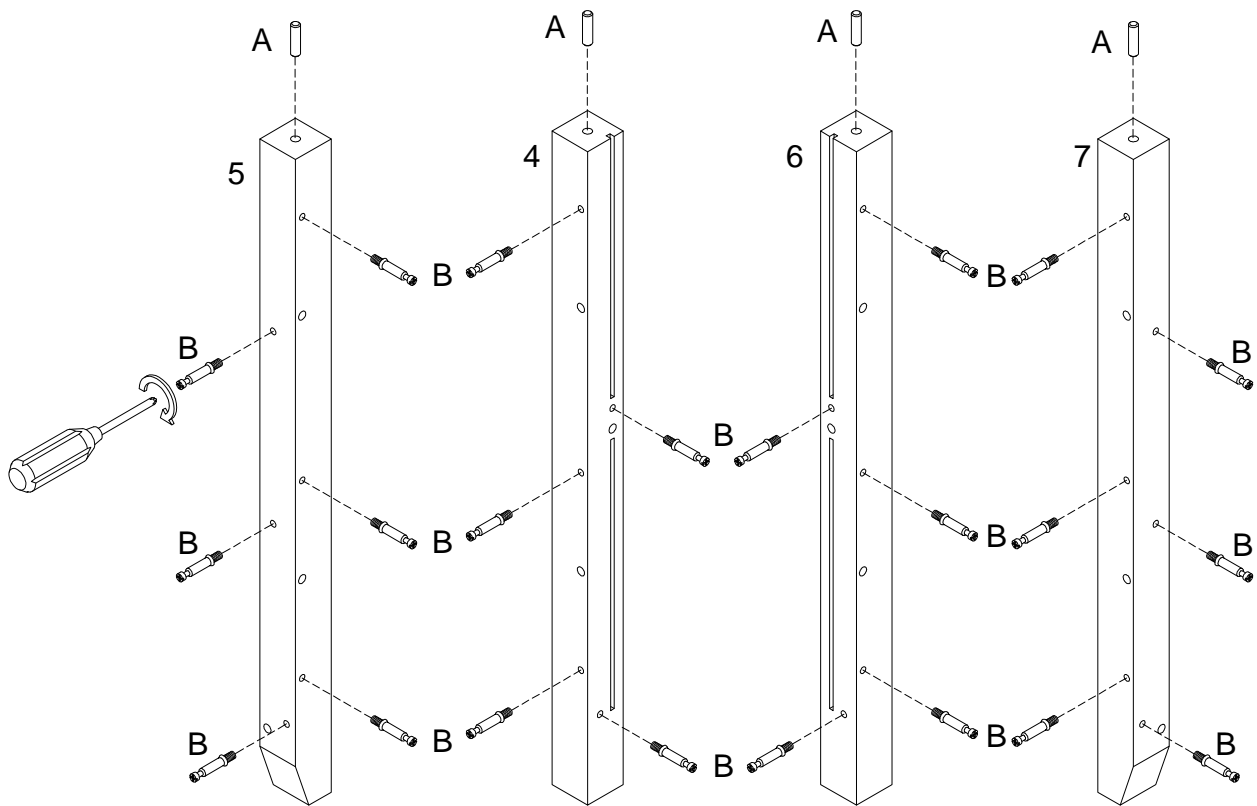

Insert wooden dowel (A) into parts (4,5,6,7) ,then secure cam bolt (B) into parts (4,5,6,7) with Philips head screwdriver as per diagram.

Step 4

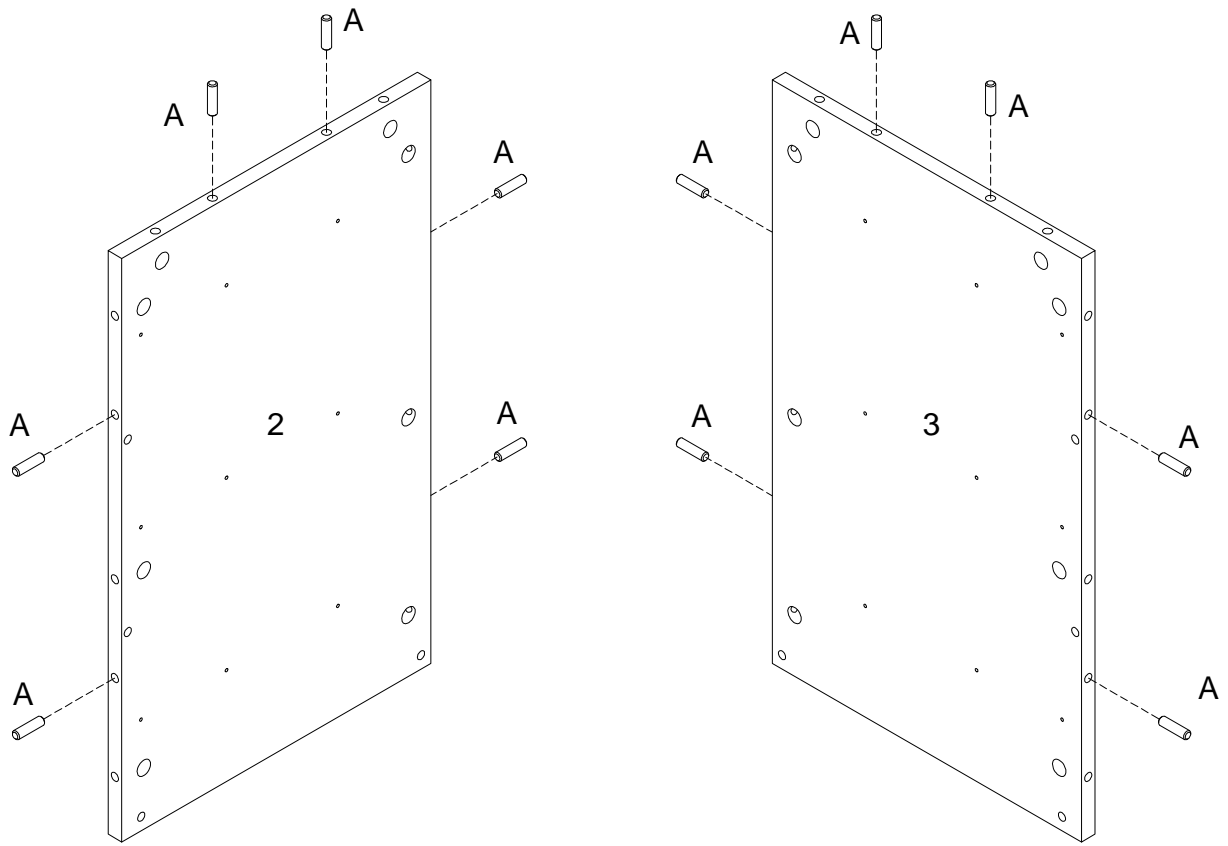

Insert wooden dowel (A) into parts (2,3) as per diagram.

Step 5

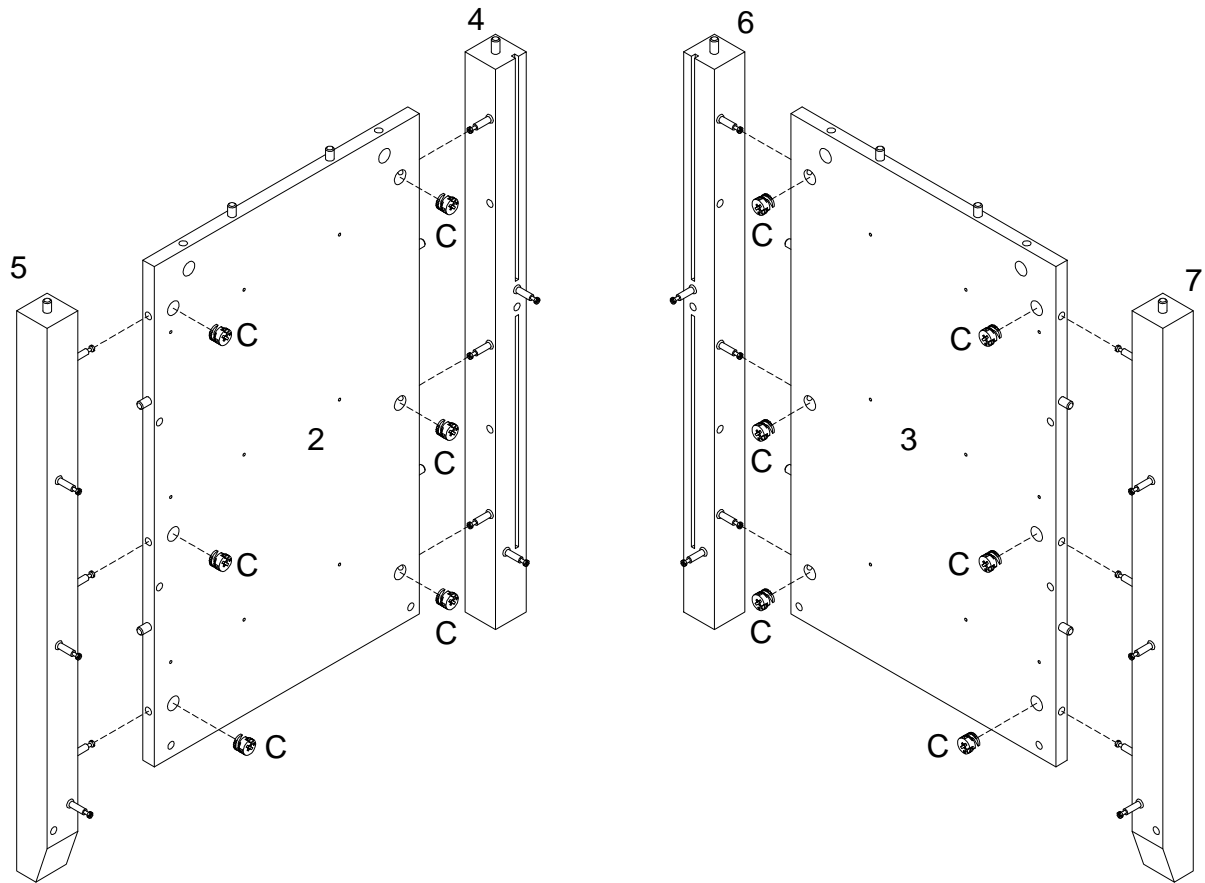
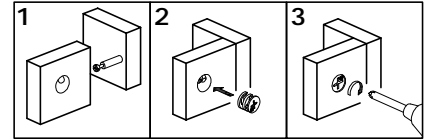

Using Cam lock(C) secure parts (4,5) to part (2) ,parts (6,7) to part (3) with Philips head screwdriver as per diagram.

Step 6

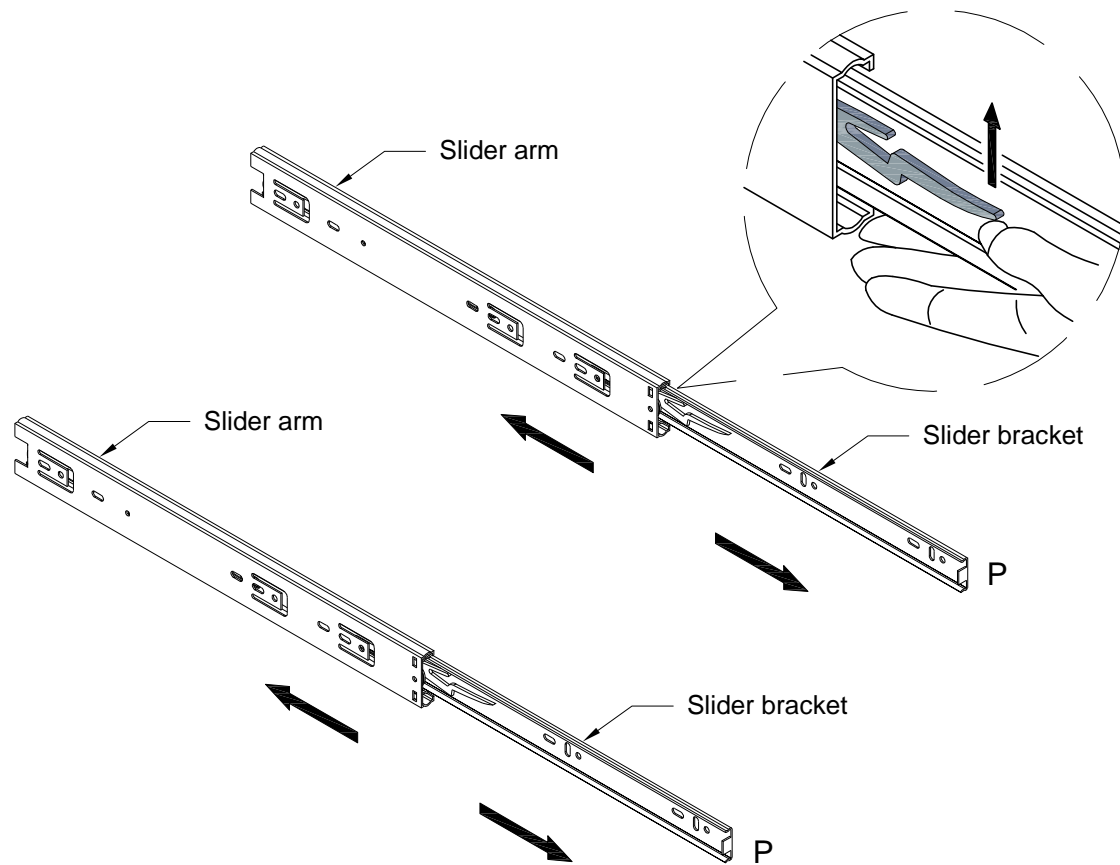

Pick up the slider arm (P) and separate the slide runner for the following Steps. Extend the slide runner all the way forward, press the plastic release lever of the slider arm up and pull the slide runner complete out .

Step 7

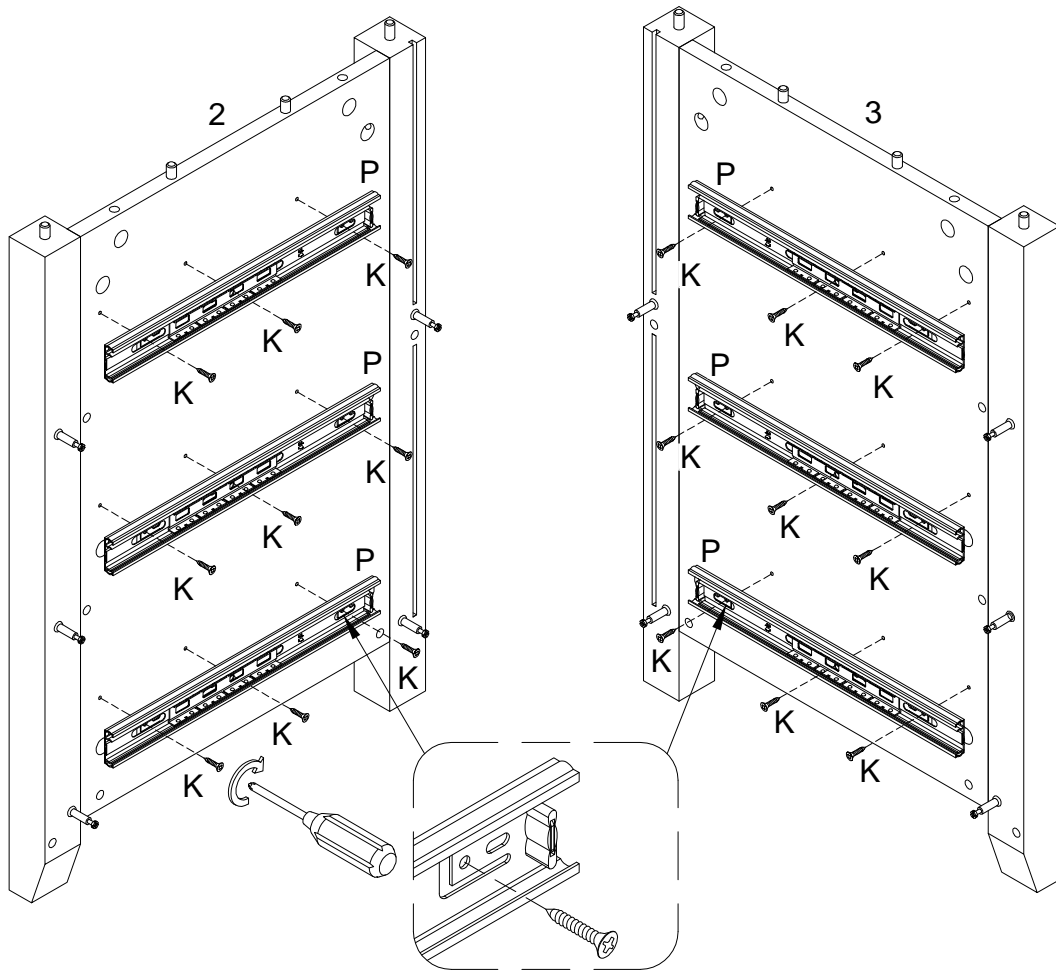

Using screw (K) attach drawer slider (P) to parts (2,3) with Philips head screwdriver as per diagram.

Step 8

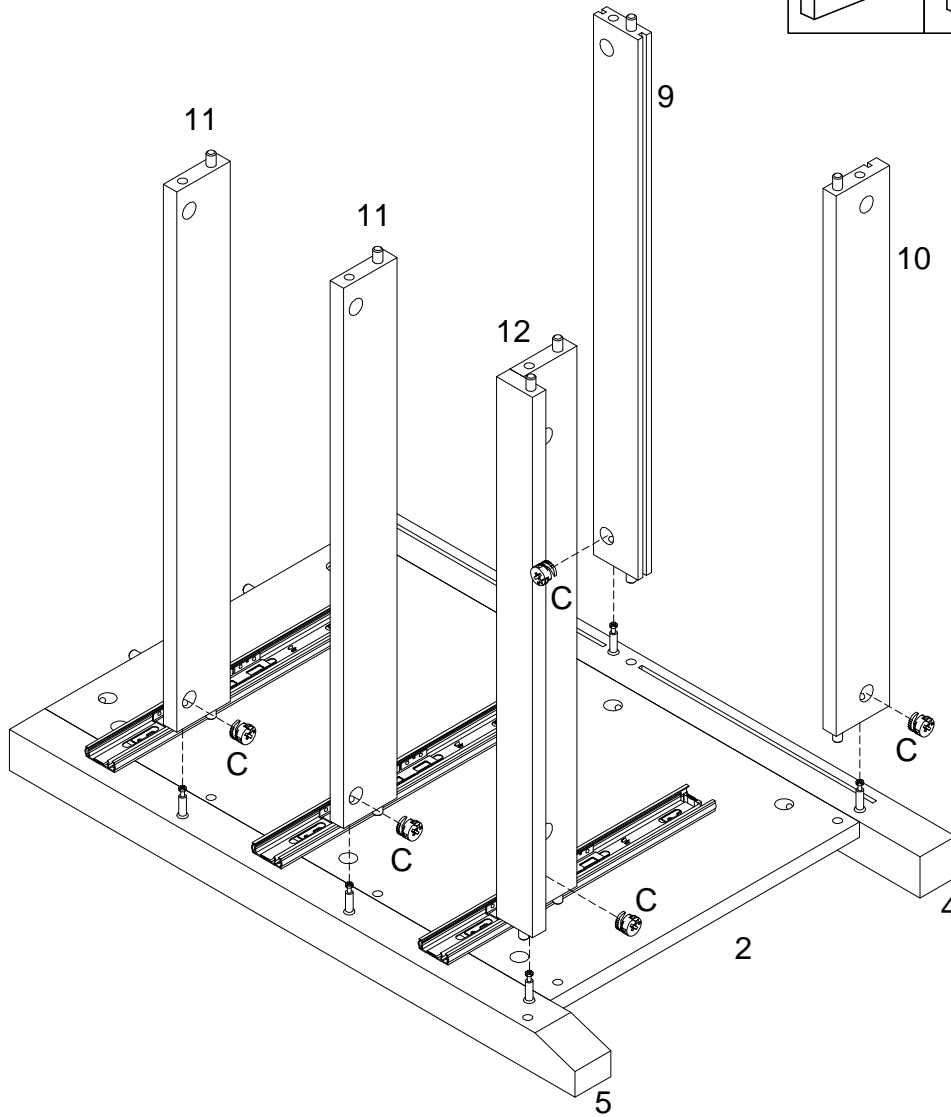
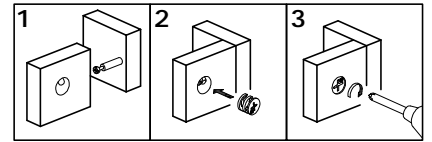

Using Cam lock(C) secure parts (9,10) to parts (2,4),parts (11,12) to parts (2,5) with Philips head screwdriver as per diagram.

Step 9

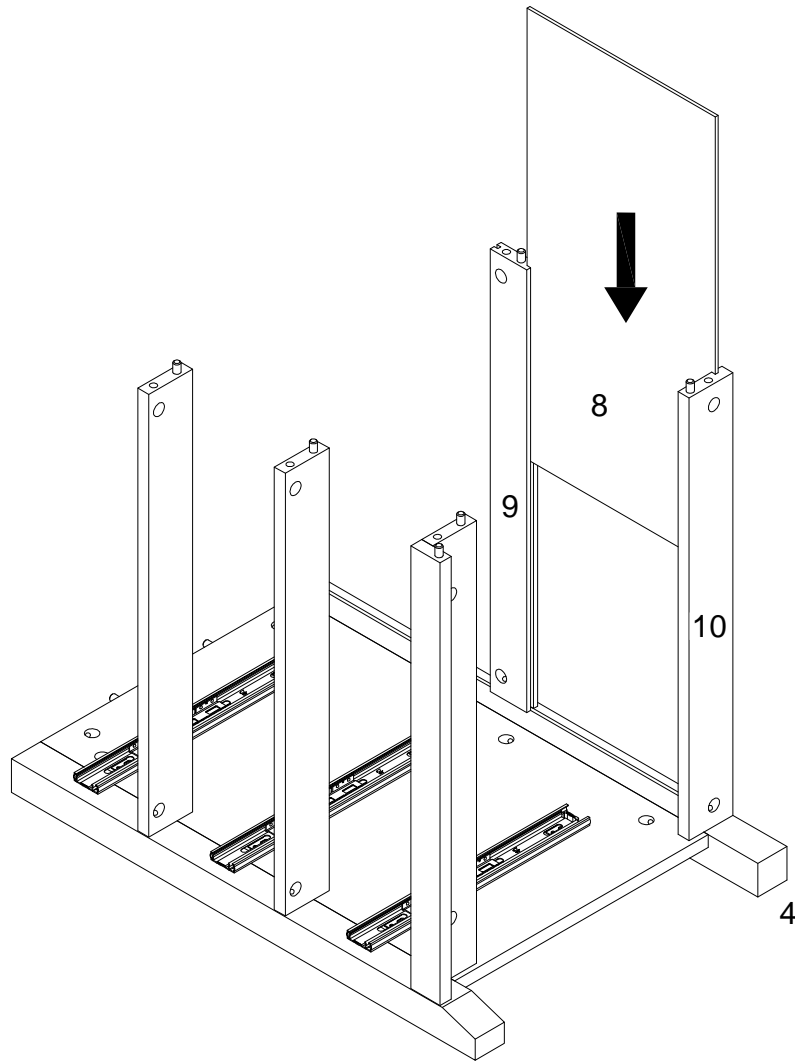

Put part (8) as per diagram.

Step 10

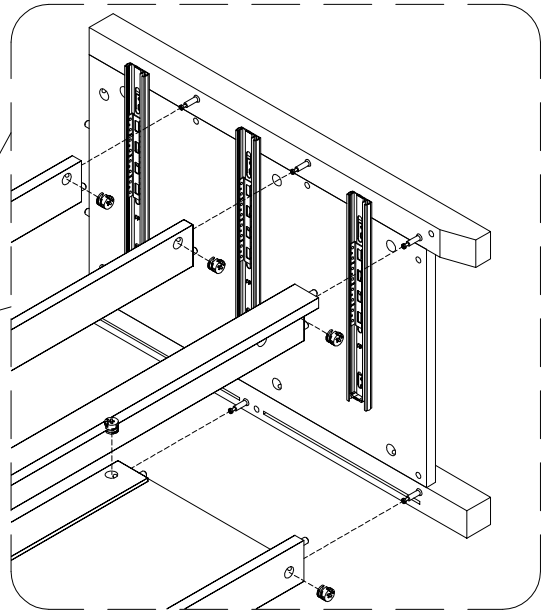
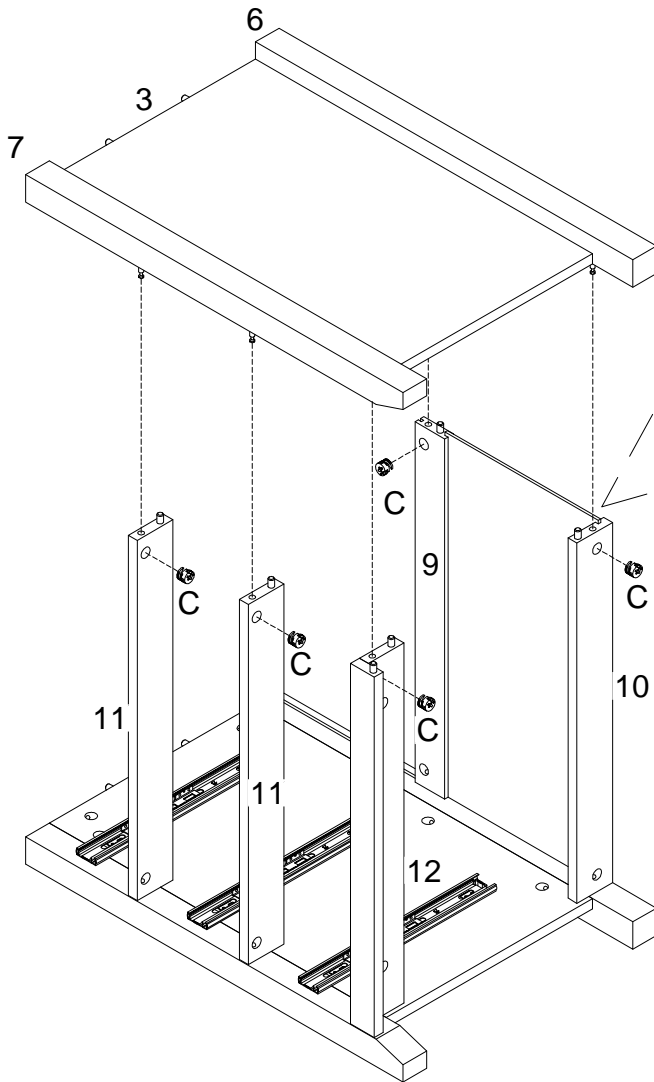
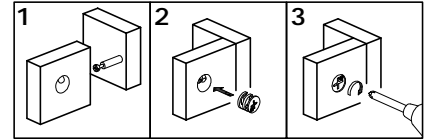

Using cam lock (C) secure parts (3,6) to parts (9,10) ,parts (3,7) to parts (11,12) with Philips head screwdriver as per diagram.

Step 11

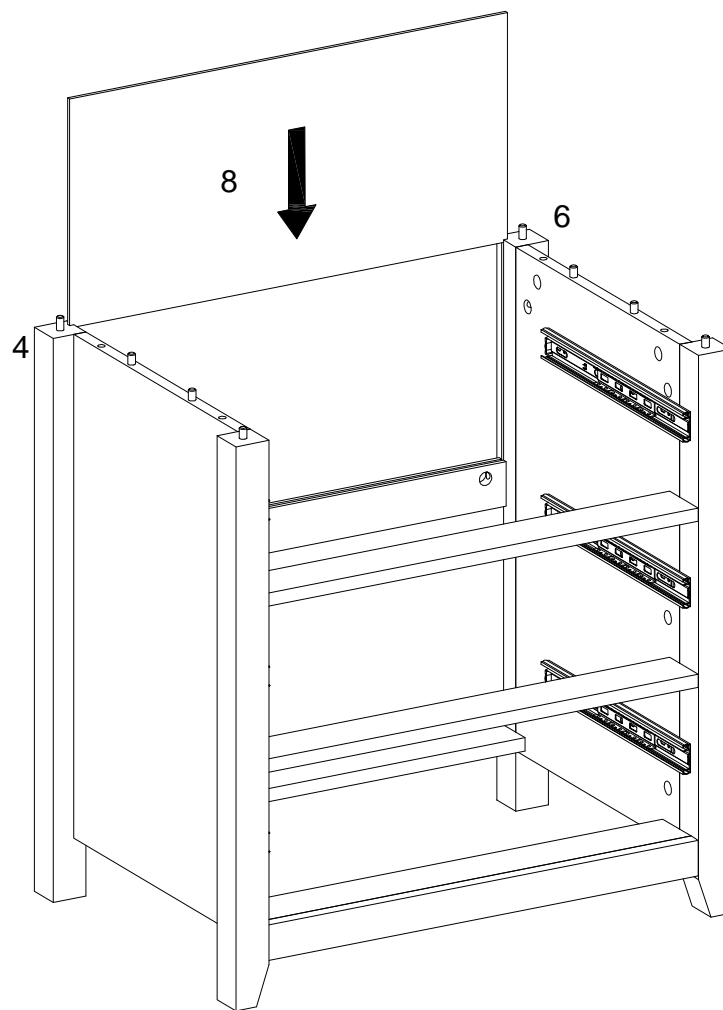

Put part (8) as per diagram.

Step 12

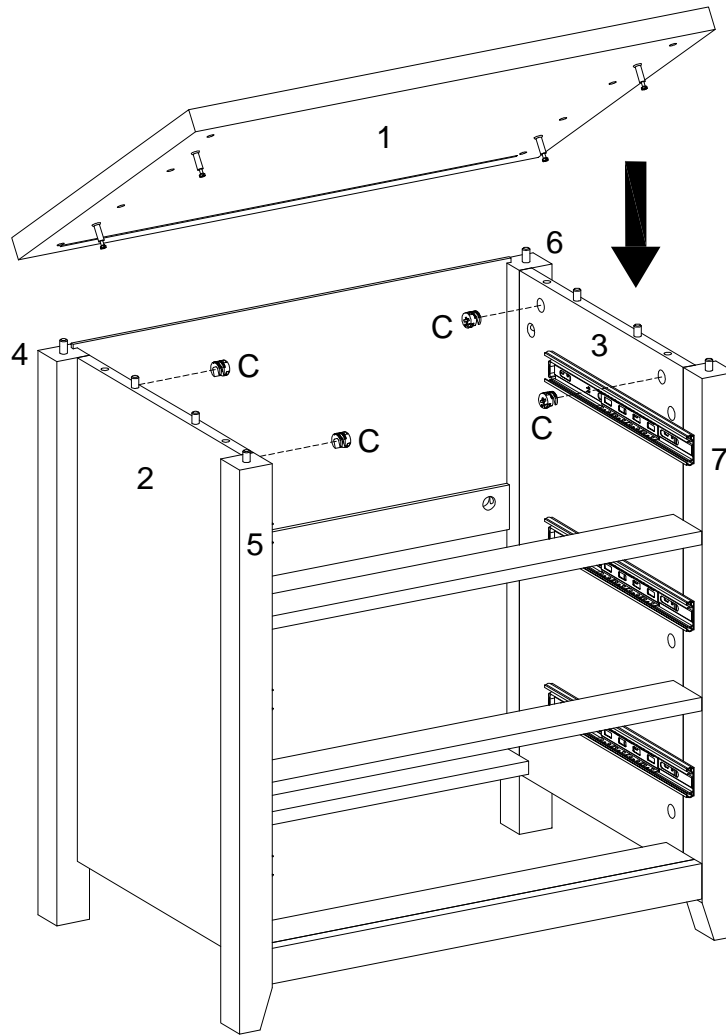
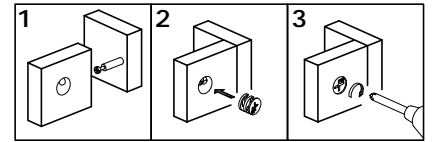

Using Cam lock(C) secure part (1) to parts (2,3,4,5,6,7) with Philips head screwdriver as per diagram.

Step 13

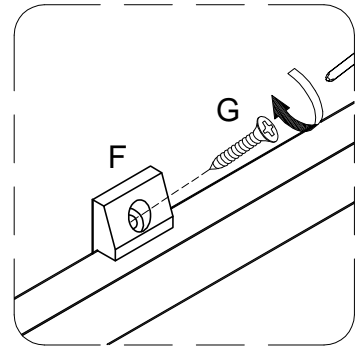
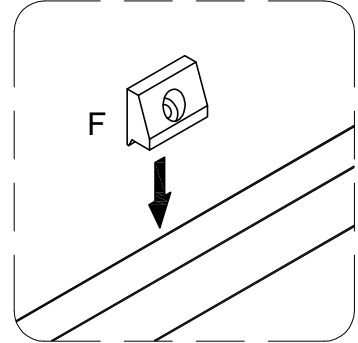
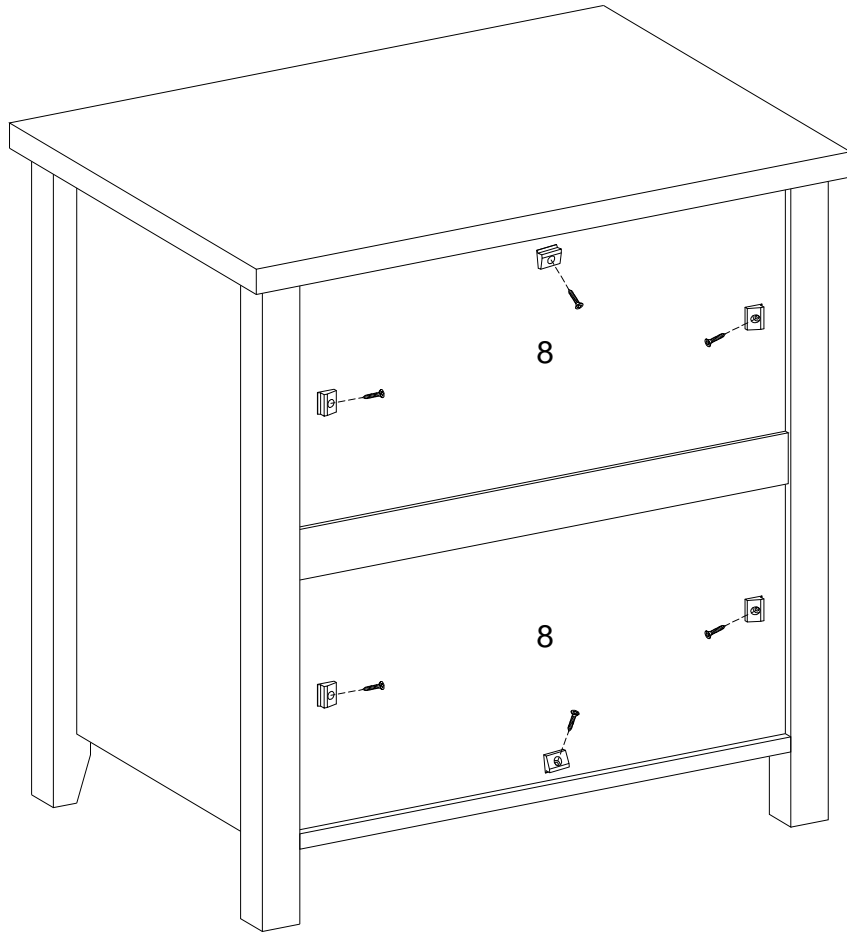

Using screw (G) secure plastic wedge (F) to parts (8) with Philips head screwdriver as per diagram.

Step 14

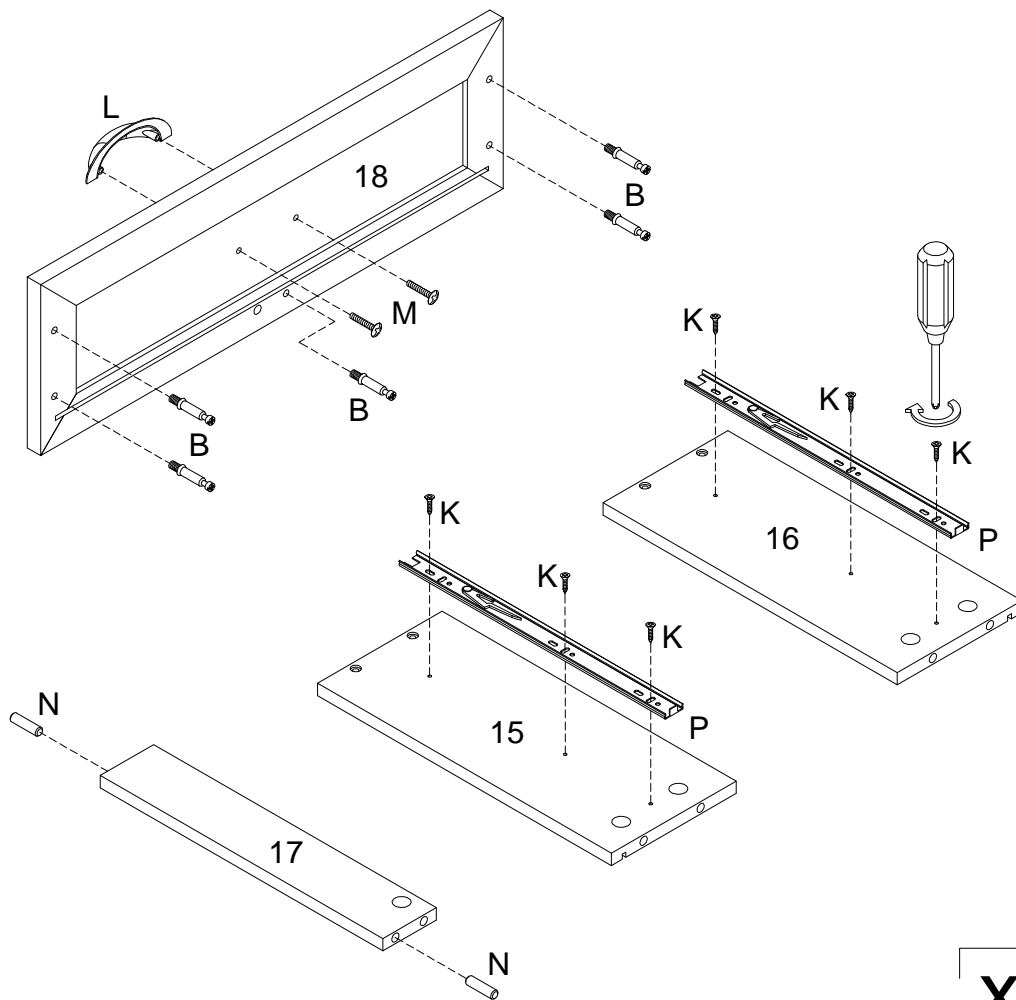

Insert wooden dowel (N) into part (17) ,secure cam bolt (B) into part (18) ,then using handle bolt (M) secure handle (L) to part (18) with Philips head screwdriver ,using screw (K) attach drawer slider (P) to parts (15,16) with Philips head screwdriver as per diagram.

Step 15

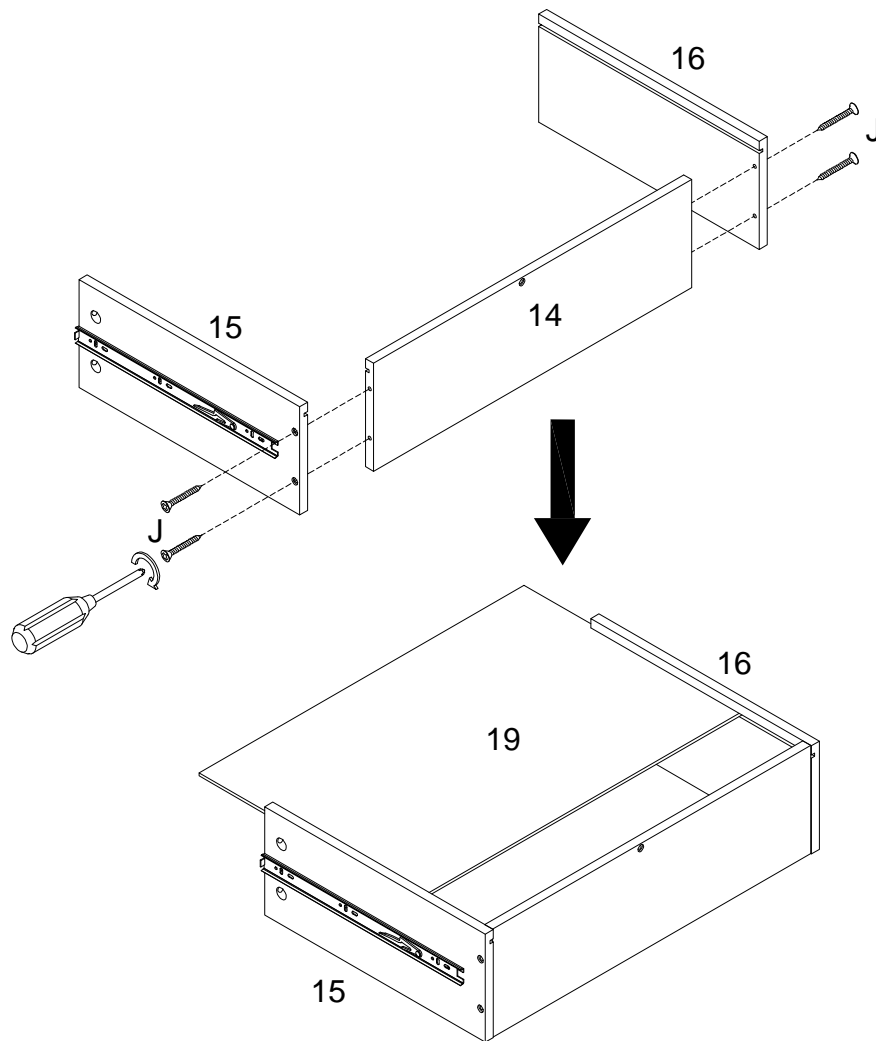

Using screw (J) attach parts (15,16) into part (14) with Philips head screwdriver ,then put part (19) as per diagram.

Step 16

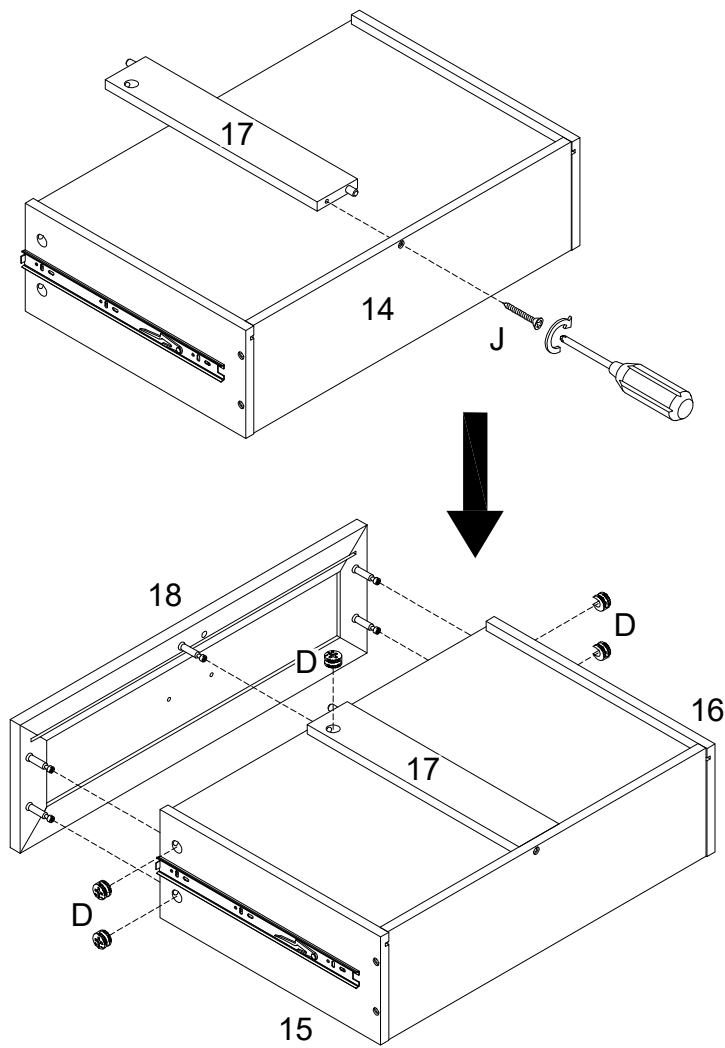

Using screw (J) attach part (17) into part (14) ,then using cam lock(D) secure part (18) to parts (15,16,17) with Philips head screwdriver as per diagram.

Step 17

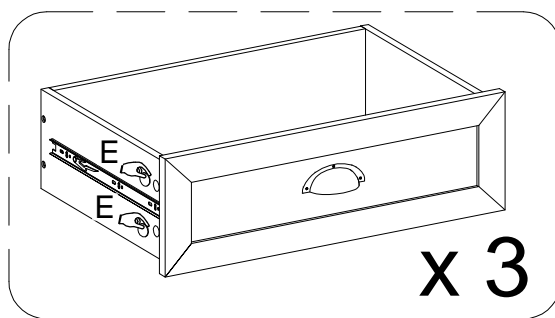
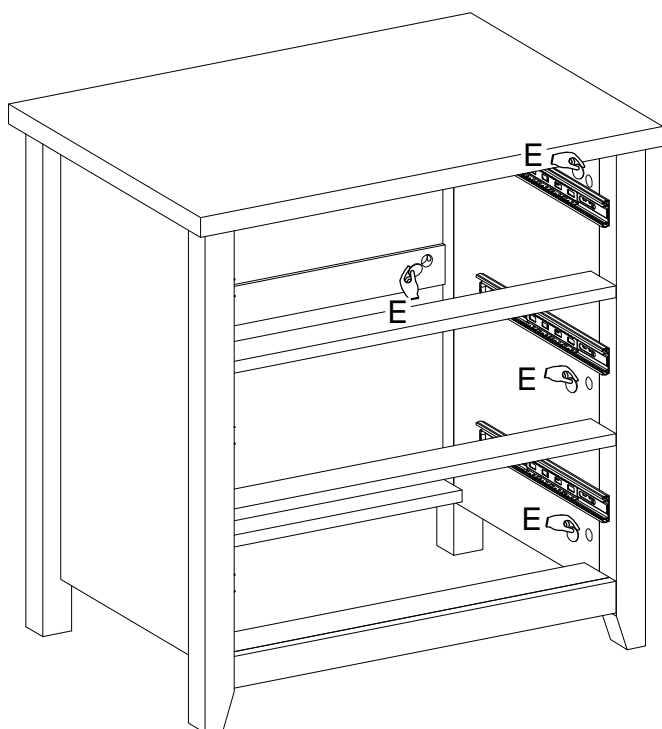

Place sticker (E) cover the holes as per diagram .

Step 18

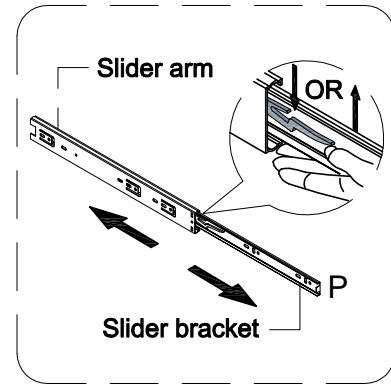
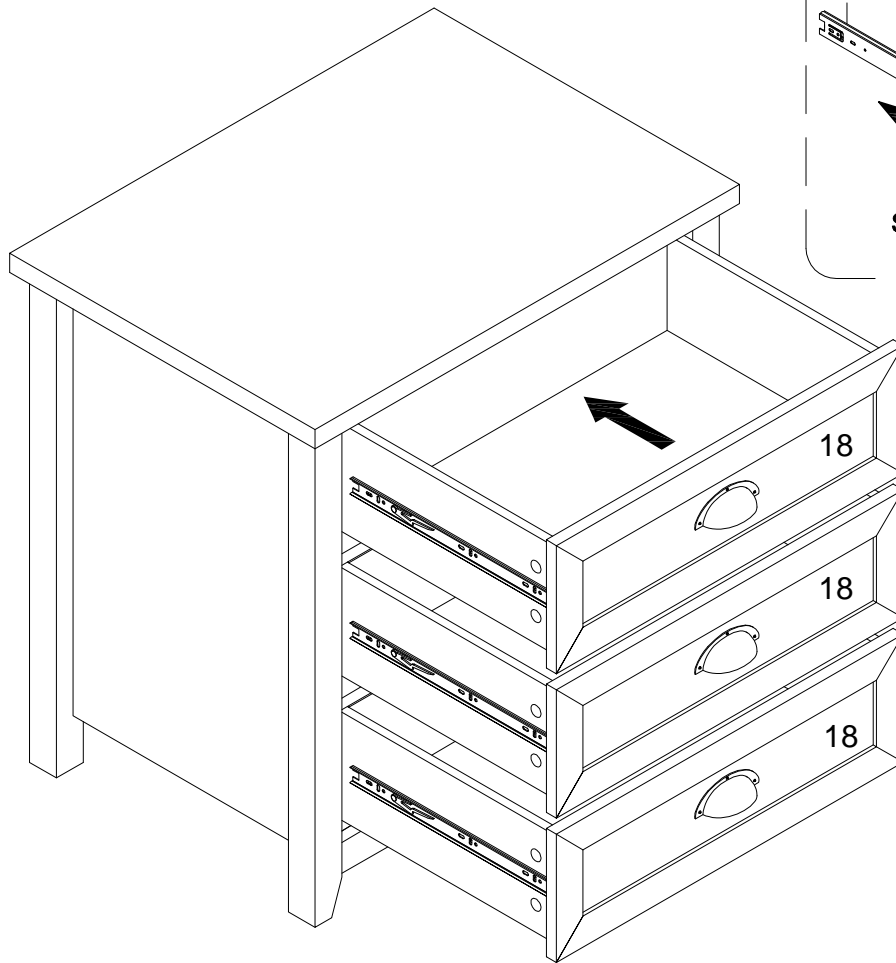

Assembled the drawers(18) as per diagram

Note :If the drawer does not go in smoothly .Press or lift the plastic release lever .

Pull out the slider bracket from the slider arm then re-assembled the drawer until they were going in smoothly well .

Step 19

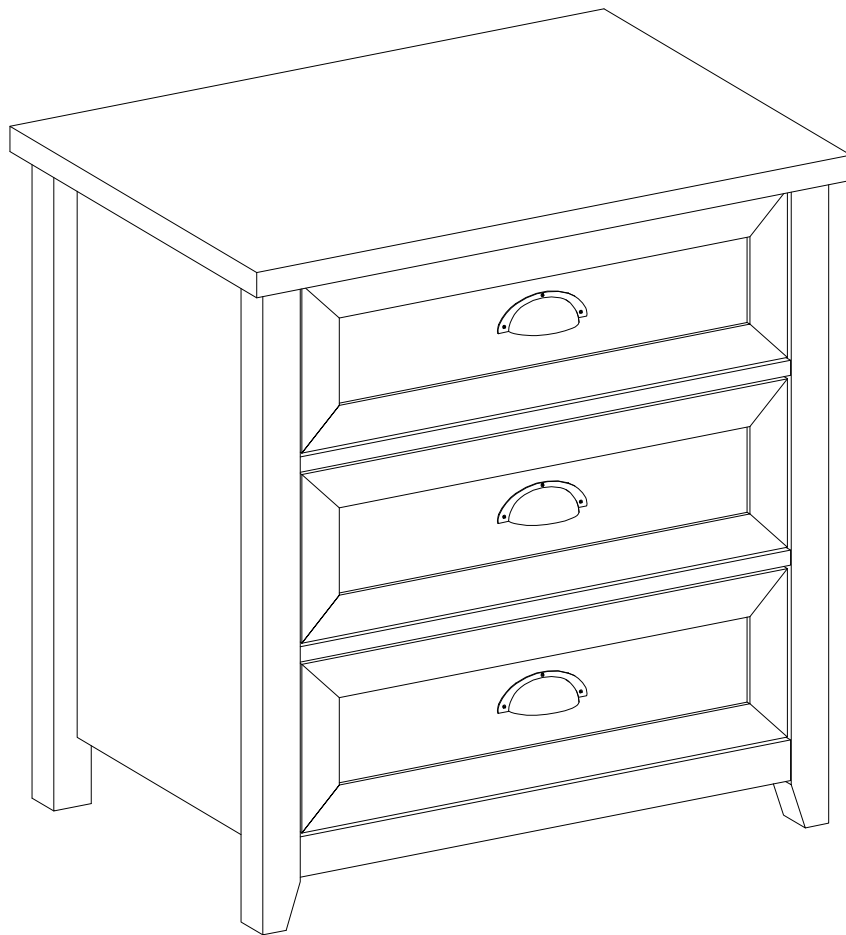

Final Assembly