

# PlumChef

## Quick Start Guide

- ① Make sure to tear off the sealing tape from the bottom of the water tank. (If it has been taken off, please skip this step)

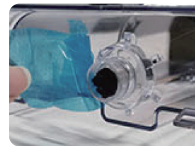

- ② Before making espresso, make sure the knob is on the OFF position.



- ③ Make sure the steam wand nozzle is clean and no blocking.



- ⑤ Plug in the power cord, press ON/OFF button, power indicator turn on. Steam indicator and espresso indicator flash, the machine is preheating.



- ⑦ Then, turn off the Steam control knob and press Espresso button again. This process is let the water flow into the empty pump for the first use.



- ⑧ After the Espresso indicator stop flashing, it means machine finish preheating, it need about 40 seconds.



Place a cup on the drip tray. Press the Espresso button to flow out the hot water to clean the filter holder or the coffee cup. Press the Espresso button again to stop.

The First Time or a Long Time Not Use The Machine  
Retain This Instruction For Future Reference

- ④ Fill water into the water tank NOT exceed the MAX line. Set up the water tank vertically and align the buckles to the hole on the back of the machine, and press it down to be parallel to the top of the machine.

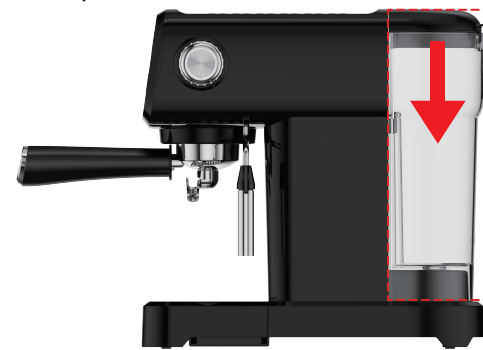

- ⑥ Place a big cup under the steam wand. Turn on the Steam control knob, Let the water flow out of the steam wand about 80ml (about 1-2 minute).



⑨



## Make Espresso Alone

- 01 Insert the filter into the filter holder. Fill ground coffee into the filter and press it with the tamp spoon. The ground coffee should be pressed evenly and not too firmly.



- 02 Install the filter holder into the machine from "Unlock" to "Lock" position. Place a cup on the drip tray.



- 03 Press the espresso button, the espresso indicator will flash, the machine start brewing. (To achieve a full flavor, the suggested volume of each cup of espresso is no more than 30ml)



- 04 Once desired amount of espresso is reached, press espresso button again to stop brewing. Enjoy your espresso.



- 05 Remove the filter holder from "Lock" to "Unlock" position. Remove the coffee grounds and clean the filter holder by water. Rinse the seal ring with wet cloth.



Note :  
Be careful the hot water of machine brewer and hot coffee grounds.

## PlumChef Froth Milk Alone

- 01 Press the milk frothing button. Please wait the milk frothing indicator stop flashing. Otherwise it comes out with weak steam, which will make bad frothing effect.



- 02 Prepare a pitcher with about 100ml / 3.4 fl.oz of milk. Insert the steam wand nozzle into the milk about 0.4-0.8 inch. Slowly turn on the steam control knob to control the steam volume.



- 03 Froth milk in the way moving vessel round from up to down, after the milk increase in volume by 2 times or the required purpose is reached, turn the knob back to "OFF" position to stop. Take away the pitcher. To make the froth more compact, it is advisable to lightly tap the pitcher on a flat surface after frothing.

Note :  
During the milk frothing, if lack of water, the machine will produce louder noise and small steam, please refill in time.

- 04 In order to prevent the steam wand nozzle from blocking and make it easier to clean, we suggest you to clean it immediately after frothing milk.



- 05 Turn off the steam control knob. Press and hold the steam wand, pull out the stainless steel sleeve. Clean the steam nozzle with damp cloth/sponge.

