

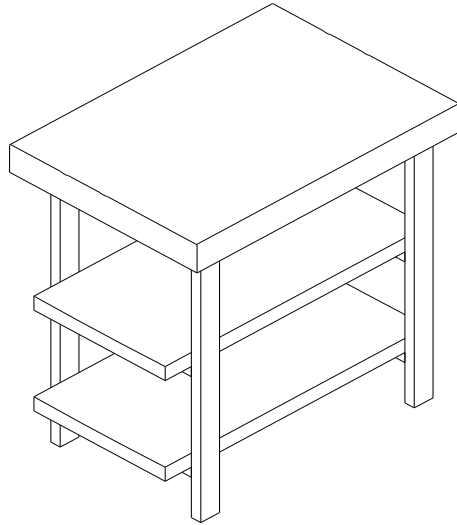

## 2 Shelf End Table



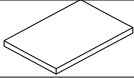
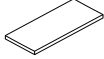

Thank you for purchasing our 2 Shelf End Table. We have found it helpful to have a second person present in at least one step of the assembly.

### Assembly Instructions

Lay out all parts on a "non-abrasive" surface to avoid scratching furniture.

NO.	DRAWING	DESCRIPTION	QTY.
A		TOP	1
B		SHELF	2
C		SIDE PANEL	2

NO.	DRAWING	DESCRIPTION	QTY.
D		M6*70mm BOLT	4
E		M6*45mm BOLT	8
F		WRENCH	1

#### Step 1

Read through these instructions thoroughly before beginning assembly. We have found this to be of great value when first assembling this product.

#### Step 2

Remove all parts and hardware from packing material. Wooden pieces should be placed on a non abrasive surface (like the carton or carpet) to prevent damage to the finish.

### Step 3

Lay Top (A) upside down and attach 2 Side Panels (C) by using 4 6M x 70mm Bolts (D).  
**DO NOT TIGHTEN FIRMLY AT THIS TIME.**

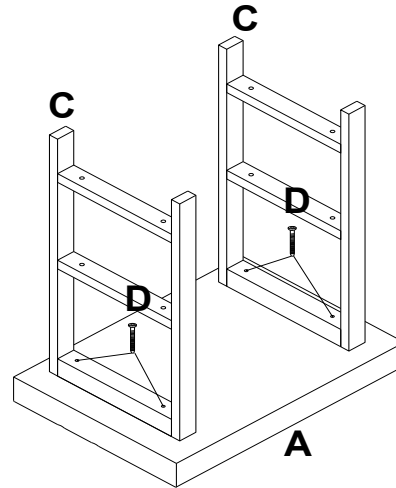

### Step 4

Note: It will help to have a second person at this time to assist in assembly.  
Lay on side and attach 2 Sheaves (B) to Side Panels (C) using 8 6M x 45mm Bolts (E).

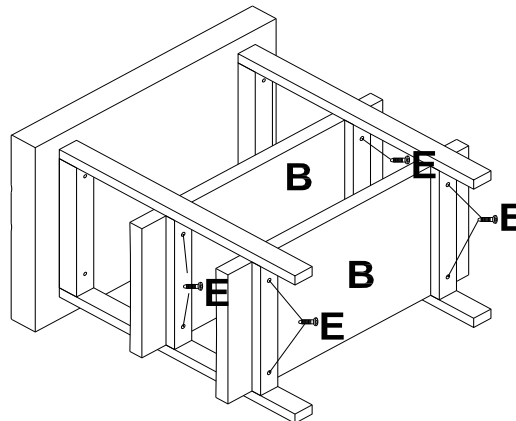

**TIGHTEN ALL BOLTS FIRMLY AT THIS TIME.**

---

### CARE

Clean with mild soap and wipe dry.

---