

Recommended Maximum Weight

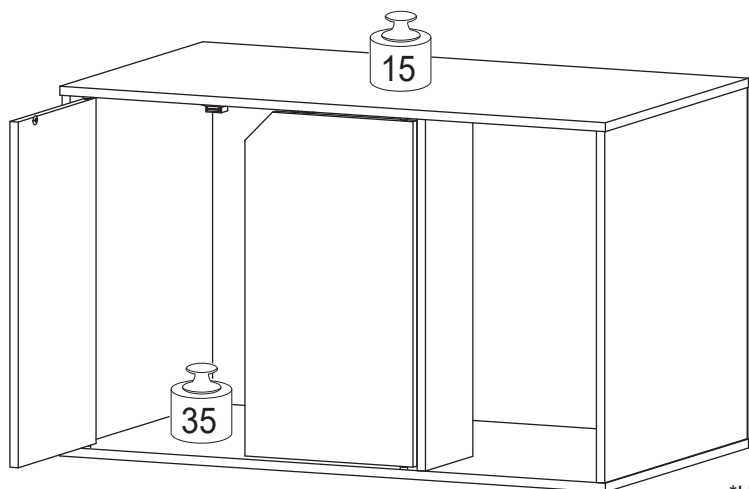

*Unit in Pound(lbs)

WARNING:

>This unit has been designed to support the maximum loads shown. Exceeding these load limits could cause sagging, instability, product collapse, and/or serious injury.

>DO NOT allow children to climb on unit.

>Put heavier items on lower shelves.

Assembly Instruction



Approx. 20 minutes

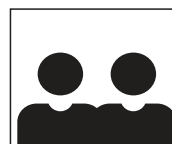



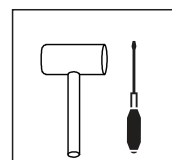

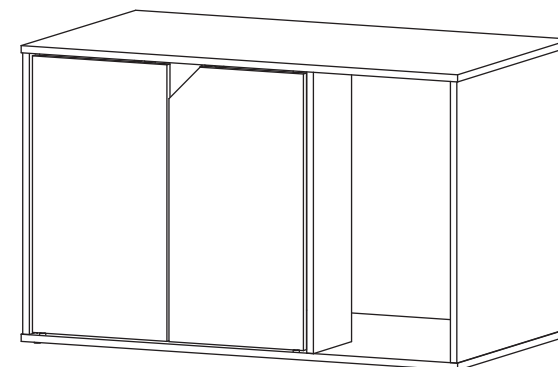

Recomm. 2 Person



Tools Required

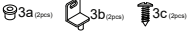

HARDWARE AND PART LIST

NO	PART LIST	QTY
1	MINIFIX 	6sets
2	POZIHEAD SCREW 	6pcs
3	HINGE KIT 	2Sets
4	MAGNET 	2pcs
5	FLAT HEAD SCREW 	2pcs
6	NAIL PIN 	4pcs
7	POWER PIN 	22pcs

NO	PART LIST	QTY
A	TOP PANEL	1pc
B	BOTTOM PANEL	1pc
C	LEFT SIDE PANEL	1pc
D	RIGHT SIDE PANEL	1pc
E	CENTER PANEL	1pc
F	DOOR RIGHT PANEL	1pc
G	DOOR LEFT PANEL	1pc
H	BACK PANEL	1pc

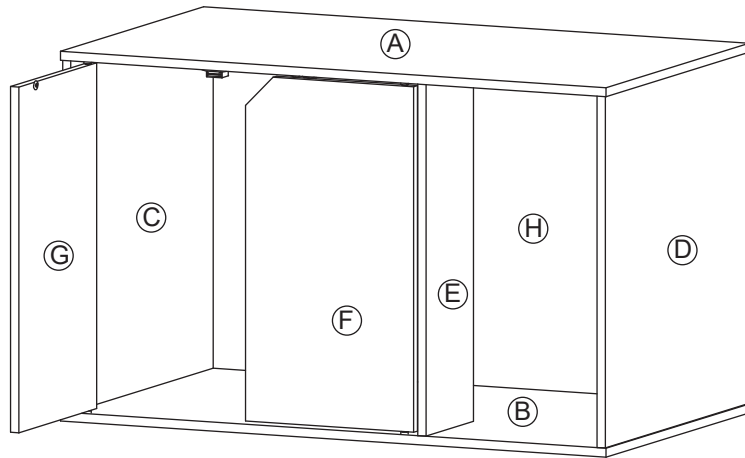

USEFUL HINTS BEFORE YOU START:

1. Read each step carefully before starting.
2. It is important that each step is performed in correct order to avoid difficulties.
3. Identify, sort and count the parts before assembly.
4. Assemble your furniture on packaging cardboard to prevent scratch or damage.
5. Clean the product with mild cleanser using soft damped cloth. Do not use harsh or abrasive cleanser.
6. Using incompatible hardware might cause damage to product.

STEP 9

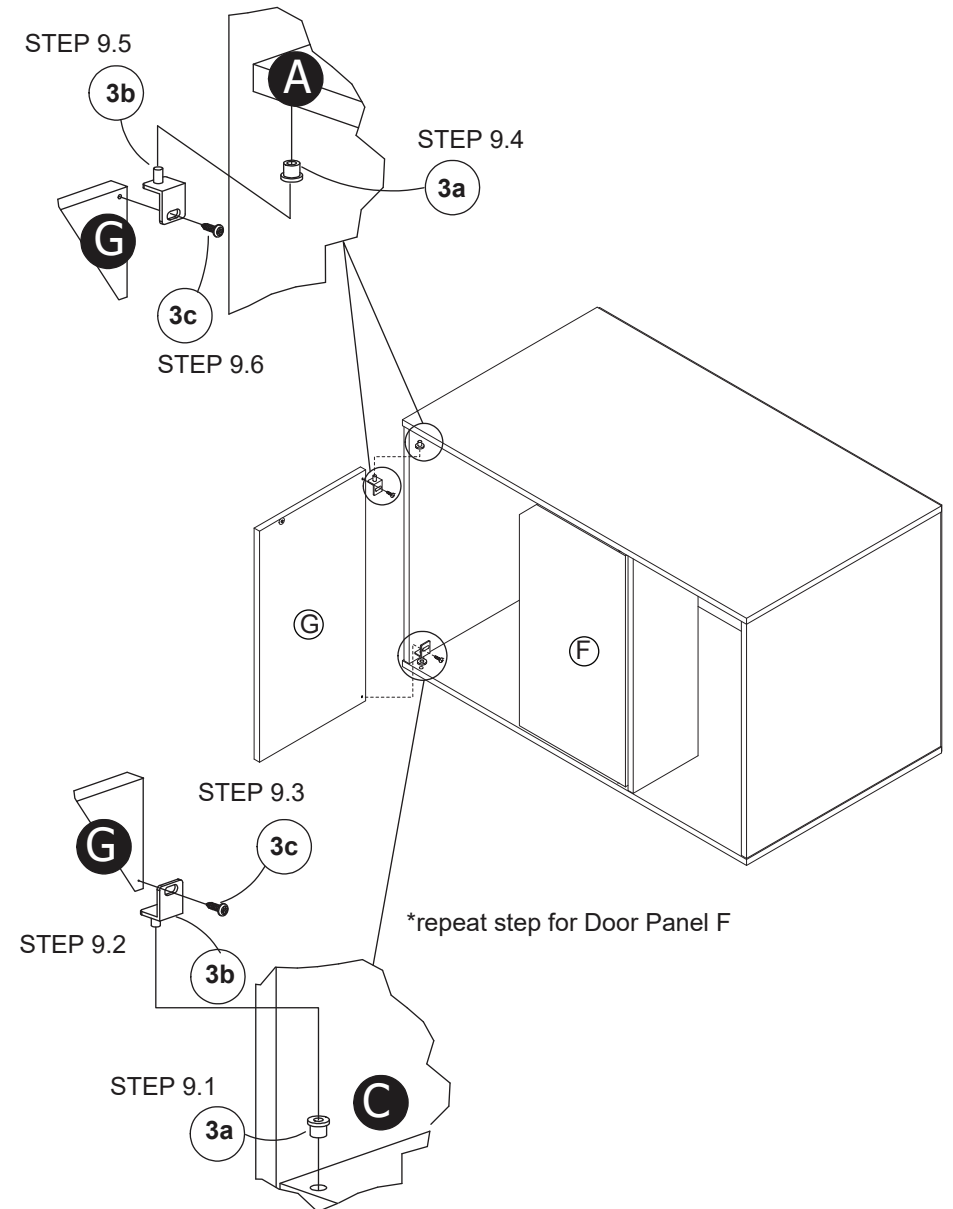

STEP 7

WARNING
WATCH YOUR HANDS AND FINGERS

TOOL REQUIRED
Mallet

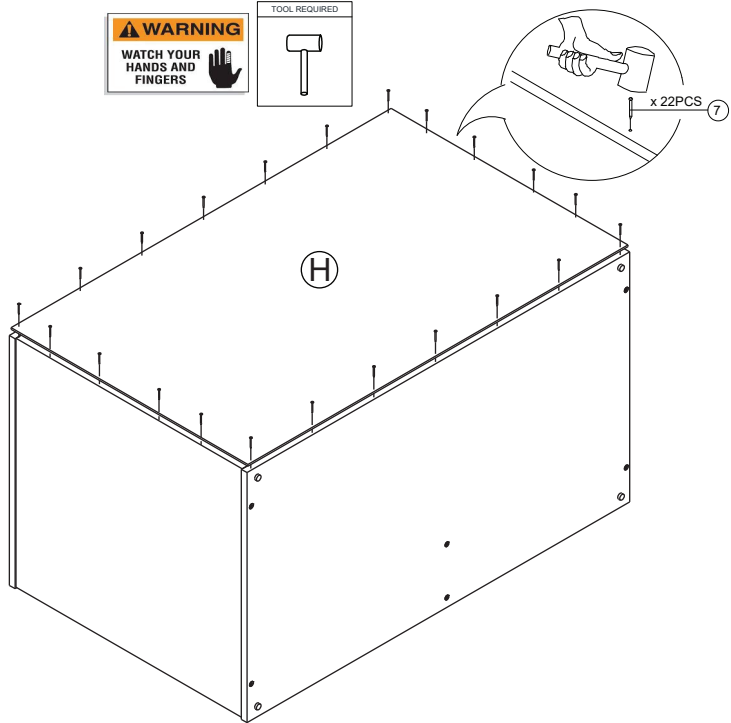

STEP 8

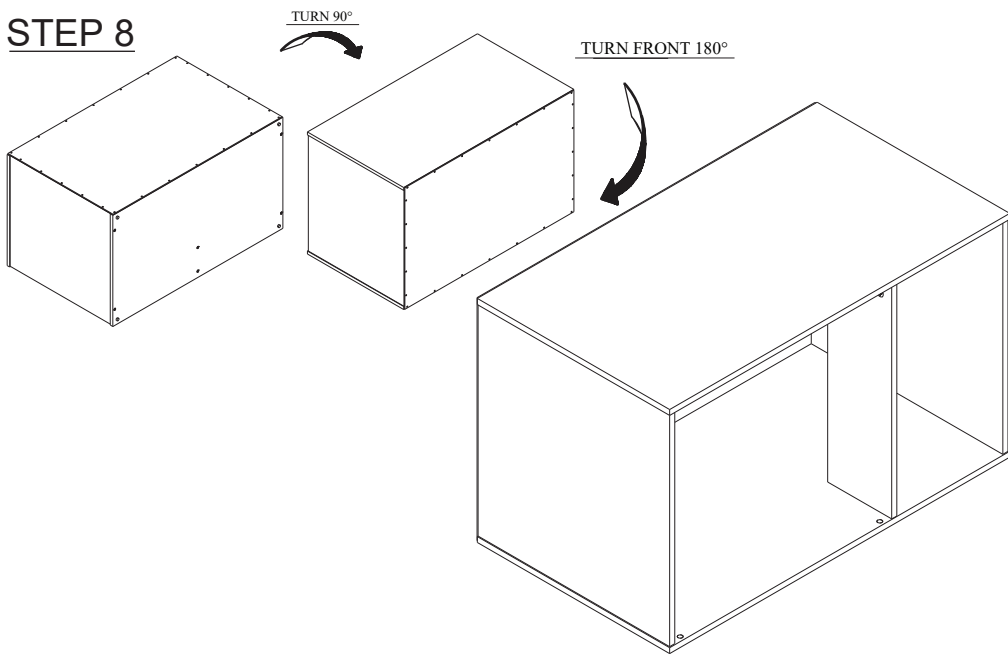

5

STEP 1

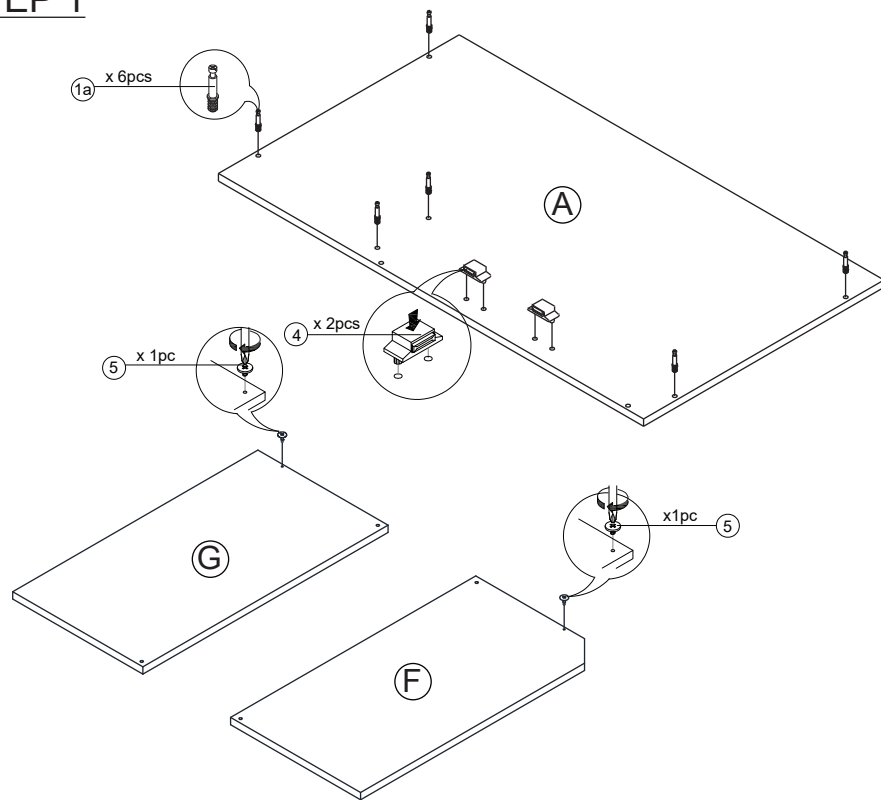

STEP 2

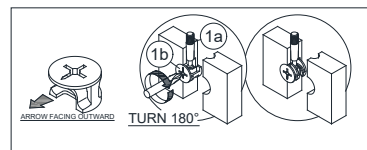

TOOL REQUIRED
Screwdriver

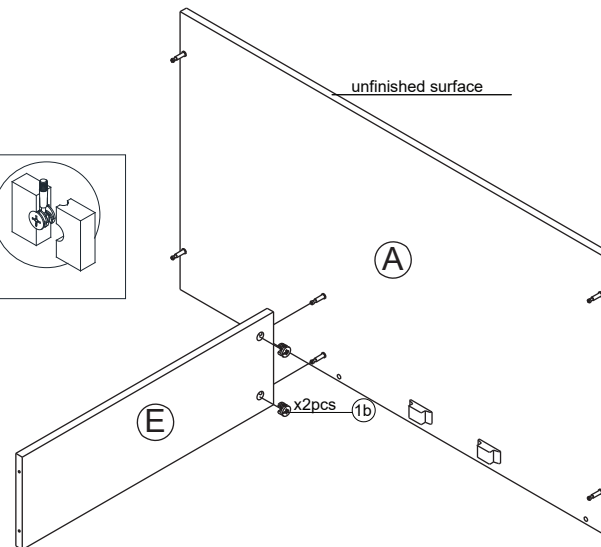

2

STEP 3

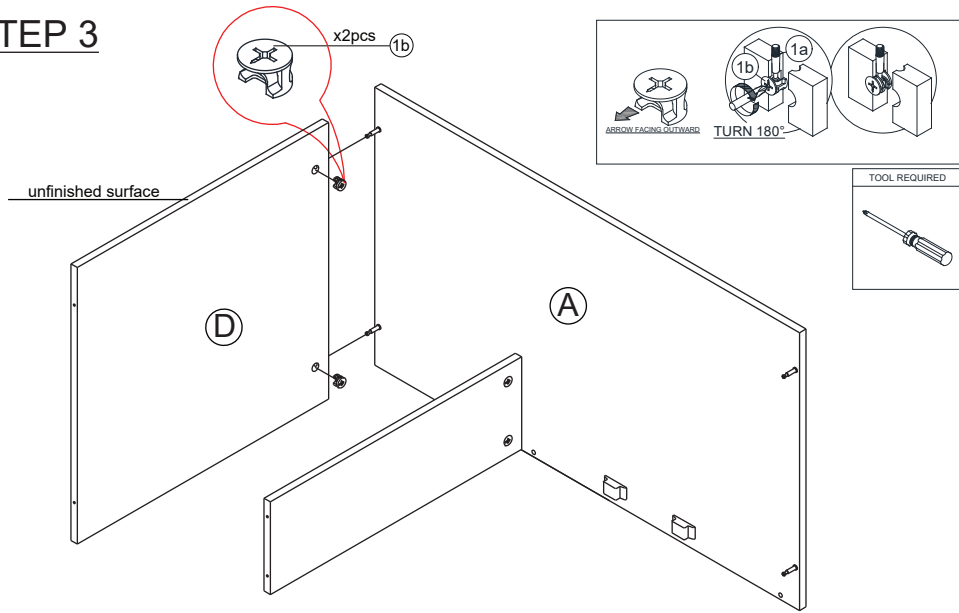

STEP 4

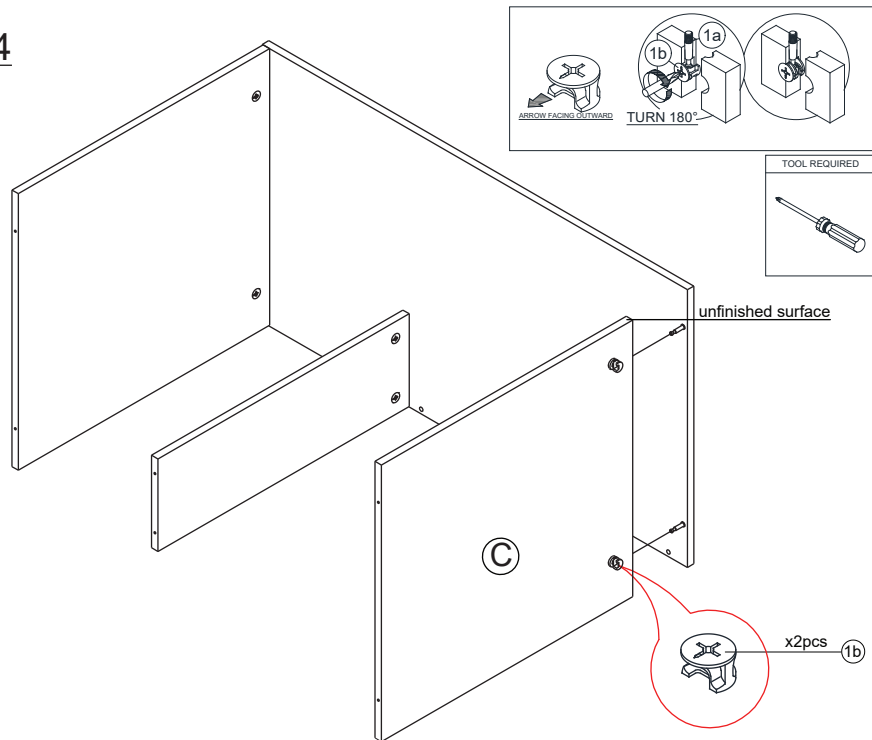

3

STEP 5

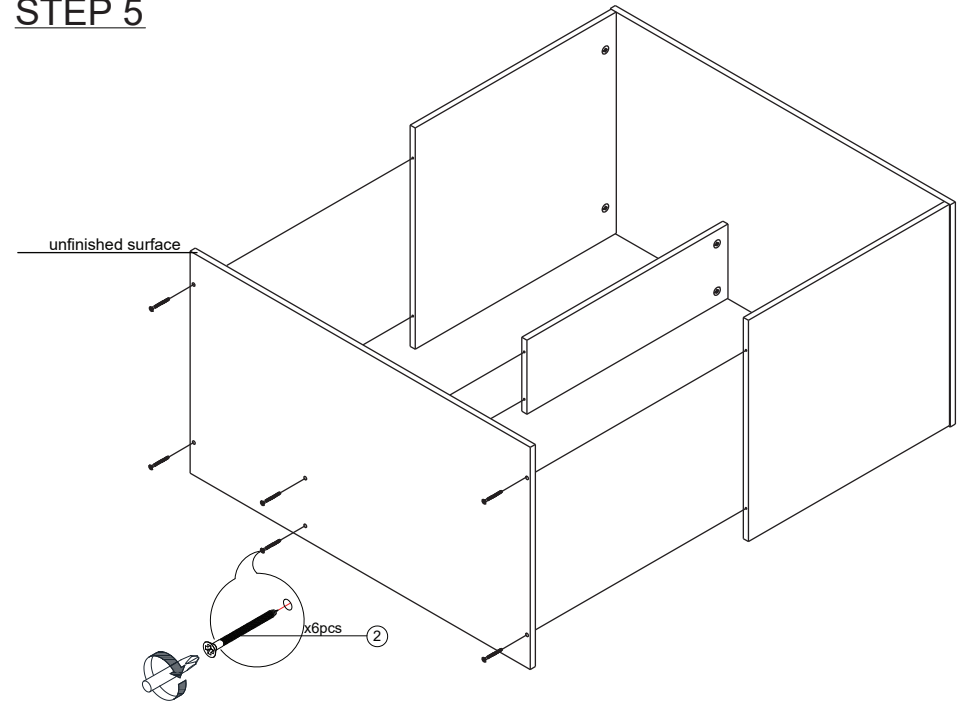

STEP 6

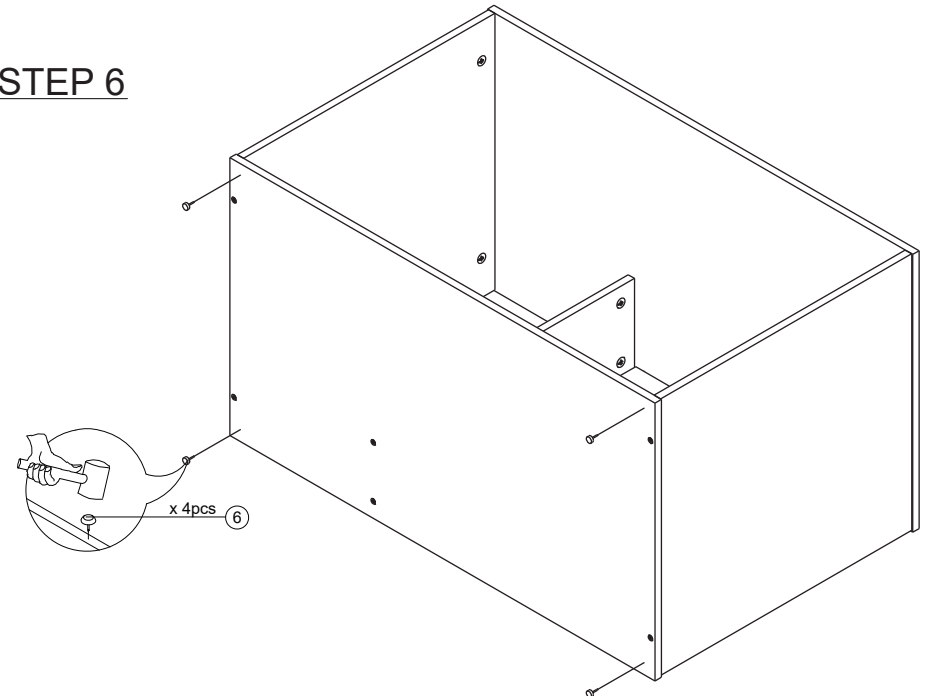

4