

"IMPORTANT, RETAIN FOR FUTURE REFERENCE: READ CAREFULLY"

German: WICHTIG, FÜR SPÄTERE NACHSCHLAGE AUFBEWAHREN: SORGFÄLTIG LESEN

Spanish: IMPORTANTE, GUARDAR PARA REFERENCIA FUTURA: LEER ATENTAMENTE

Italian: IMPORTANTE, CONSERVARE PER RIFERIMENTI FUTURI: LEGGERE ATTENTAMENTE

French: IMPORTANT, À CONSERVER POUR RÉFÉRENCE FUTURE : LIRE ATTENTIVEMENT

- ⚠ 1. Periodically check that all components are tightly secured.
- 2. Assemble on a flat, clean, and soft surface.
- 3. Confirm all parts are present prior to assembly.
- 4. Prepare electric tools in advance for a quicker installation.







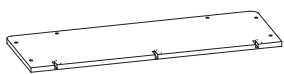
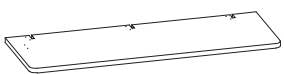
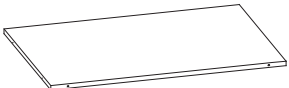
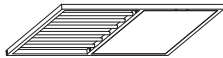
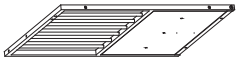
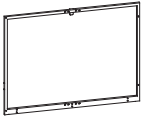
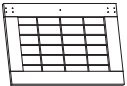
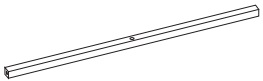

- 1. Prüfen Sie regelmäßig, ob alle Komponenten fest sitzen.
- 2. Montieren Sie das Gerät auf einer ebenen, sauberen und weichen Oberfläche.
- 3. Vergewissern Sie sich vor dem Zusammenbau, dass alle Teile vorhanden sind.
- 4. Bereiten Sie Elektrowerkzeuge im Voraus vor, um eine schnellere Installation zu ermöglichen.



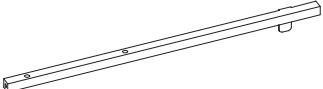
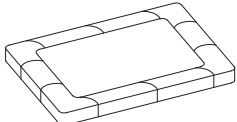
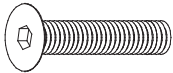
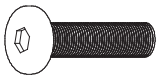
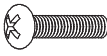



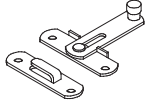

- 1. Vérifiez périodiquement que tous les composants sont bien fixés.
- 2. Assemblez le tout sur une surface plane, propre et douce.
- 3. Confirmez que toutes les pièces sont présentes avant l'assemblage.
- 4. Préparez les outils électriques à l'avance pour une installation plus rapide.

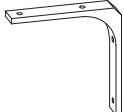
- 1. Controllare periodicamente che tutti i componenti siano fissati saldamente.
- 2. Assemblare su una superficie piana, pulita e morbida.
- 3. Assicurarci che siano presenti tutte le parti prima dell'assemblaggio.
- 4. Preparare gli strumenti elettrici in anticipo per un'installazione più veloce.

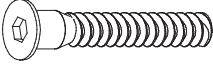
- 1. Revise que todos los componentes estén asegurados con regularidad.
- 2. Monte sobre una superficie que sea plana, limpia y suave.
- 3. Antes de montar el producto, revise que tenga todas las piezas a mano.
- 4. Para facilitar la instalación, prepare las herramientas eléctricas necesarias con tiempo.

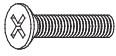
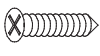
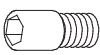
Item no. Nr. N° d'article Articolo No. Artículo No.	Reference Image Referenzbild Image de référence Immagine di riferimento Imagen de referencia	Qty. Menge Qté. Qtà Cant.	Item no. Nr. N° d'article Articolo No. Artículo No.	Reference Image Referenzbild Image de référence Immagine di riferimento Imagen de referencia	Qty. Menge Qté. Qtà Cant.
1		X1	2		X1
3		X1	4		X1
5		X1	6		X1
7		X2	8		X3

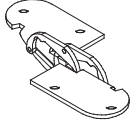
Item no. Nr. N° d'article Articolo No. Artículo No.	Reference Image Referenzbild Image de référence Immagine di riferimento Imagen de referencia	Qty. Menge Qté. Qtà Cant.
9		X1
11		X2
13		X1
15		X1
B	 M6*23mm	X6
D	 M6*20mm	X2
F	 M4*18mm	X2
H	 ST4*14mm	X38
J	 plastic	X2
L		X1
N		X1
P		X2

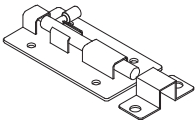
Item no. Nr. N° d'article Articolo No. Artículo No.	Reference Image Referenzbild Image de référence Immagine di riferimento Imagen de referencia	Qty. Menge Qté. Qtà Cant.
10		X1
12		X1
14		X1
A	 M6.3*40mm	X13
C	 M6*23mm	X17
E	 M4*10mm	X14
G	 ST4*18mm	X4
I		X2
K	 metal	X1
M		X3
O		X2
Q		X4

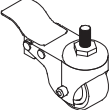
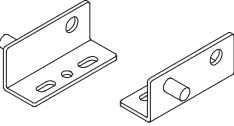
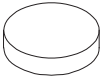
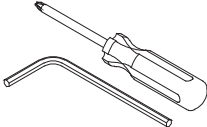
Item no. Nr. N° d'article Articolo No. Artículo No.	Reference Image Referenzbild Image de référence Immagine di riferimento Imagen de referencia	Qty. Menge Qté. Qtà Cant.	Item no. Nr. N° d'article Articolo No. Artículo No.	Reference Image Referenzbild Image de référence Immagine di riferimento Imagen de referencia	Qty. Menge Qté. Qtà Cant.
R		X4	S		X2
T		X3	U		X1

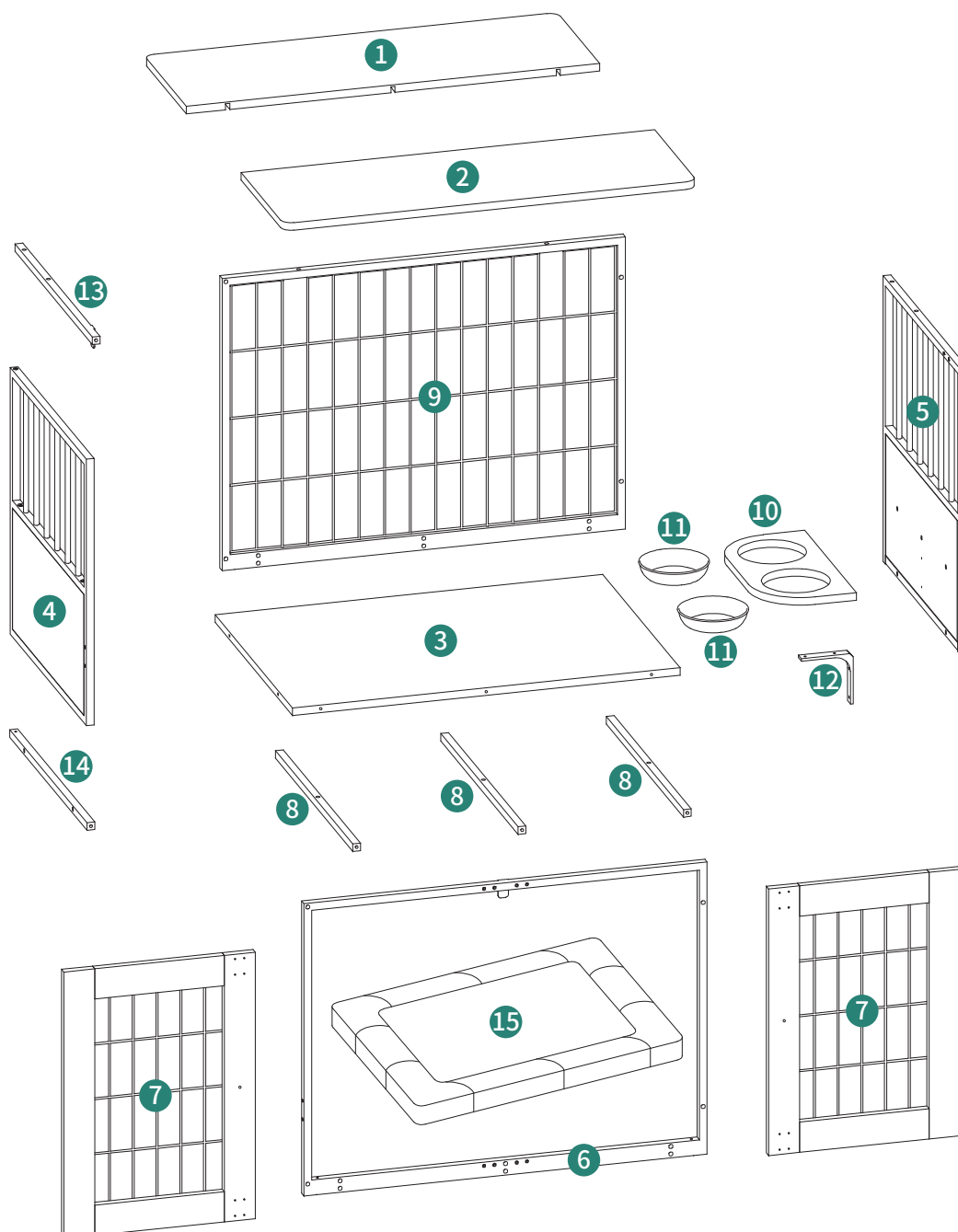

1

plastic

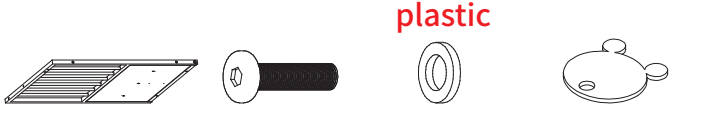

⑤ 1pc ④ 2pcs ③ 2pcs ② 2pcs

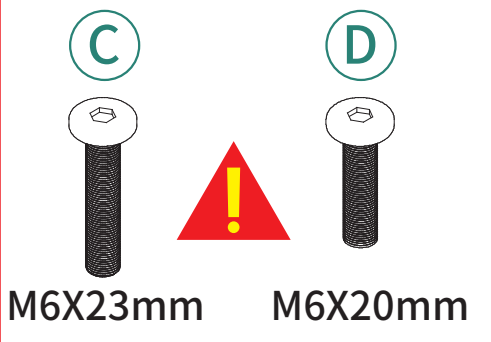

③ M6X23mm ④ M6X20mm

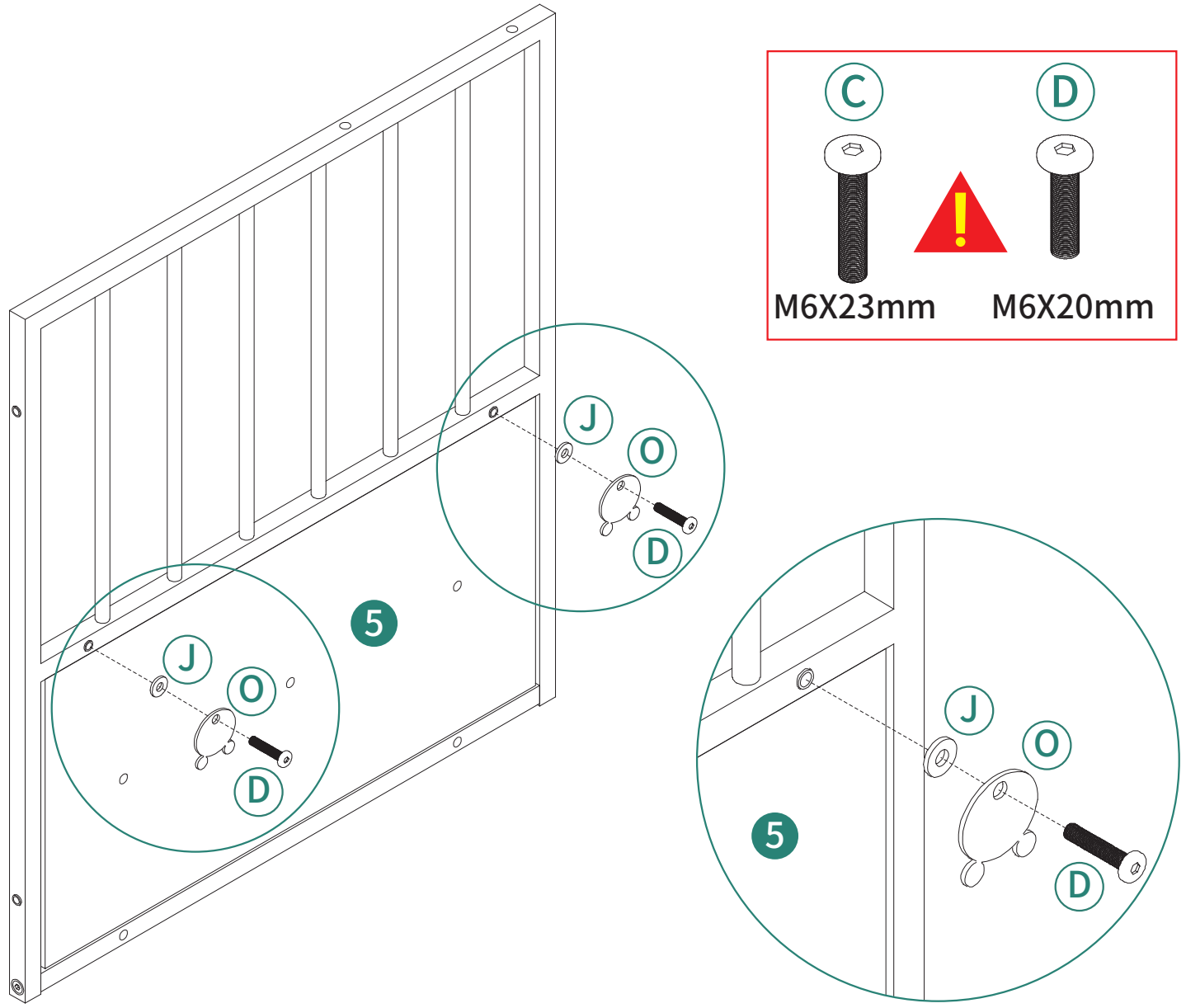

Note: Do not fully tighten the screws to ensure that accessory L can rotate.

Beachten Sie: Ziehen Sie die Schrauben nicht vollständig fest, um sicherzustellen, dass das Zubehör L gedreht werden kann.

Remarque : Ne serrez pas complètement les vis pour permettre à l'accessoire L de tourner.

Nota: non stringere completamente le viti per garantire che l'accessorio L possa ruotare.

Nota: No apriete completamente los tornillos para asegurarse de que el accesorio L pueda girar.

2

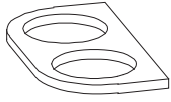

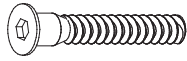

10 1pc

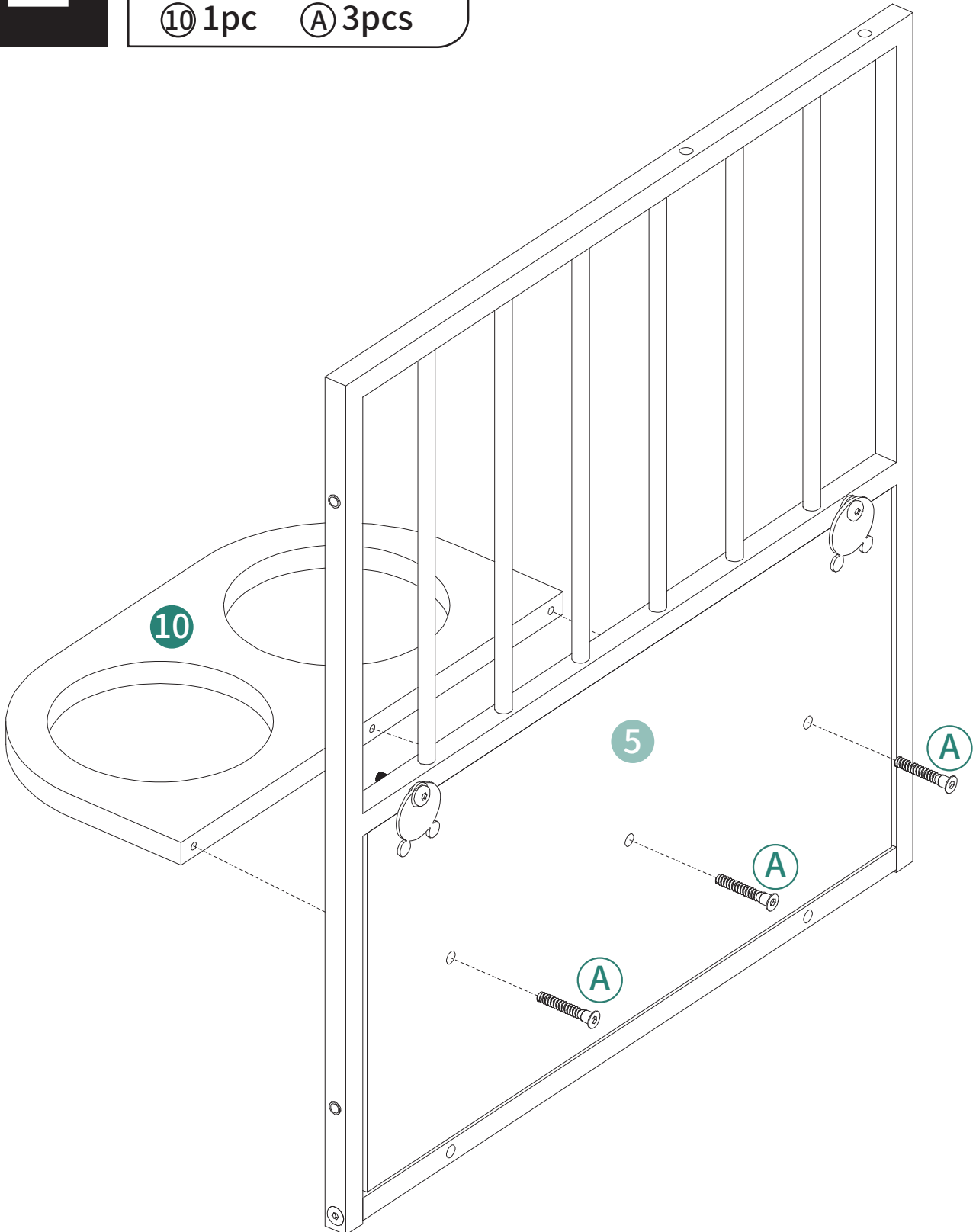

A 3pcs



3

  
⑪ 2pcs ⑫ 1pc ⑮ 4pcs

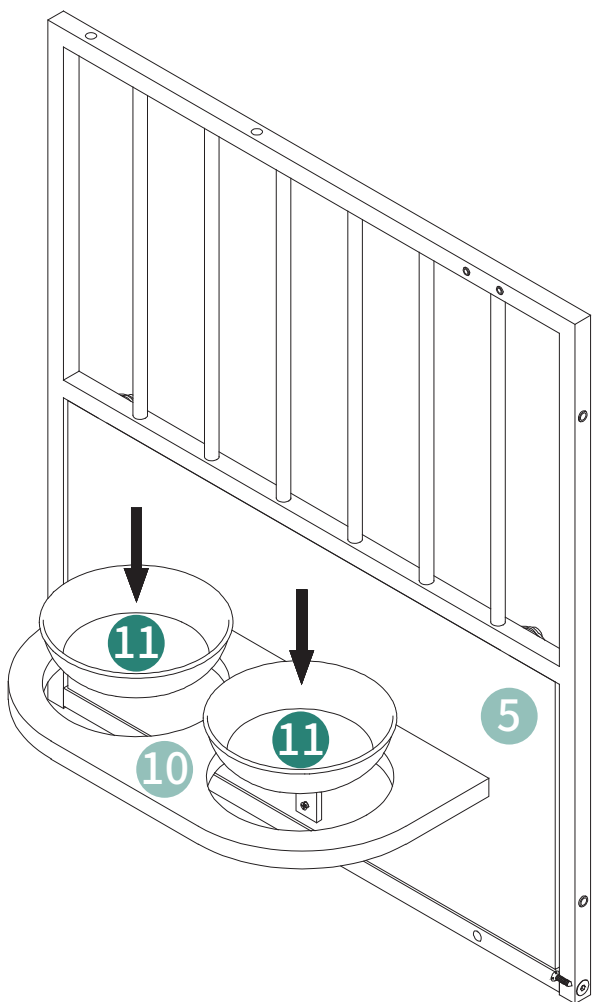
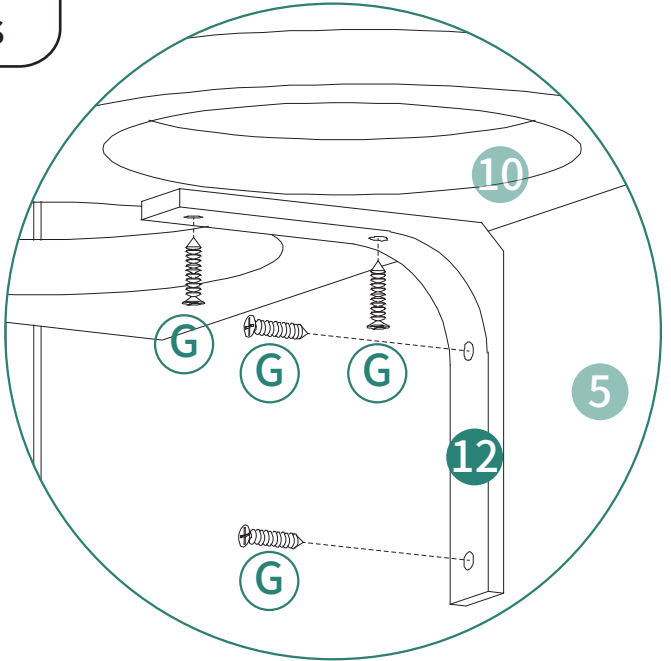
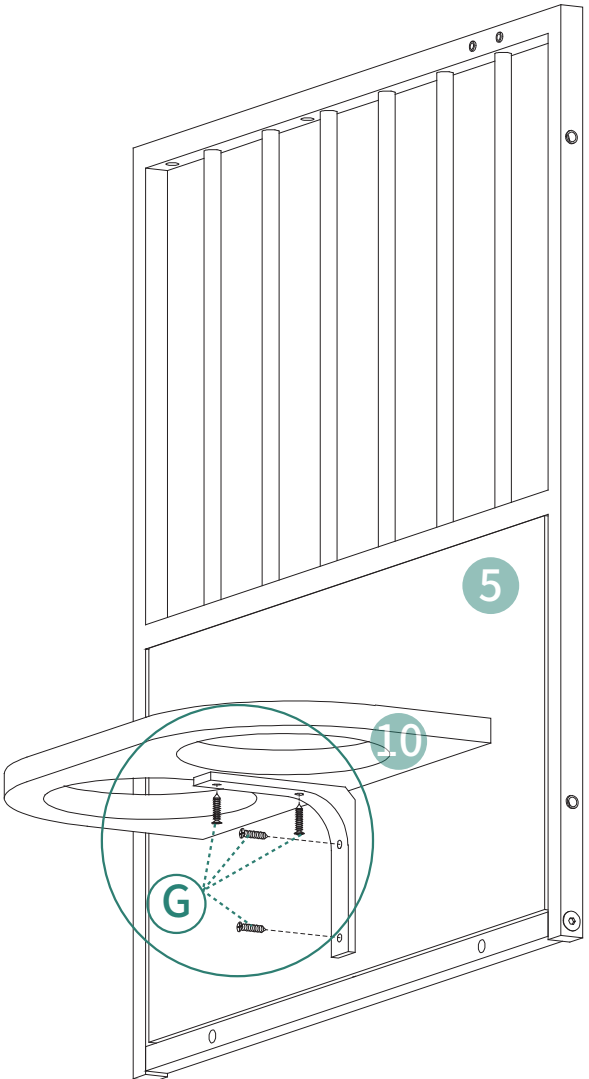

4

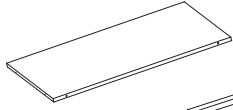

③ 1pc

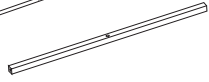

⑧ 3pcs



Ⓒ 3pcs

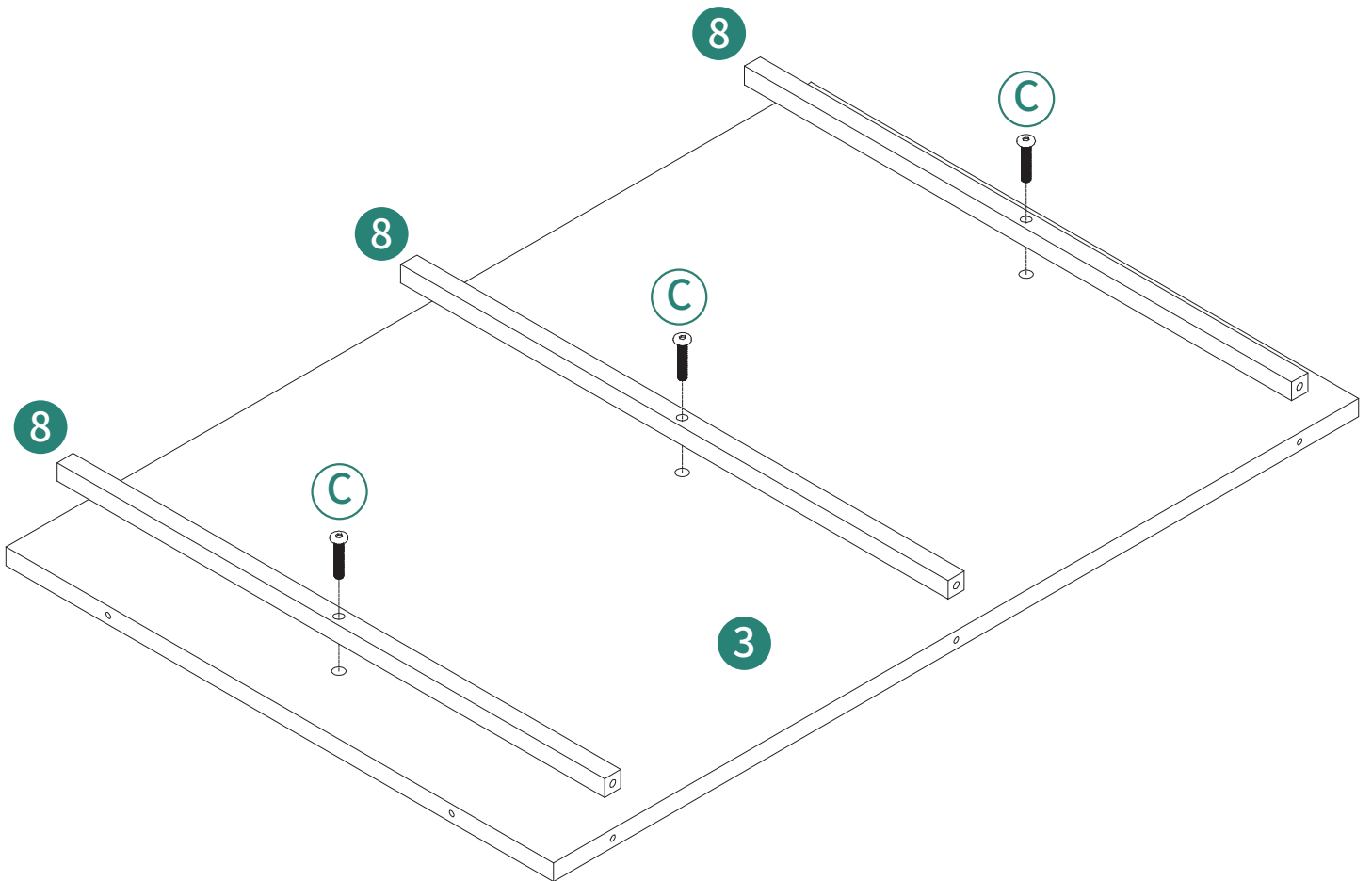

5

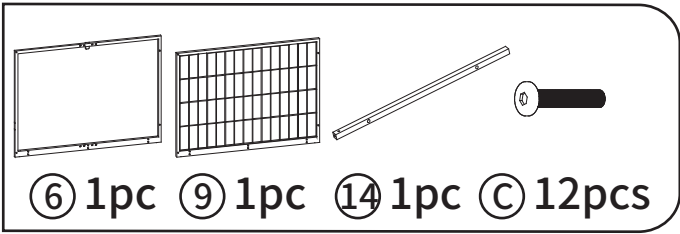

⑥ 1pc ⑨ 1pc ⑭ 1pc ① 12pcs

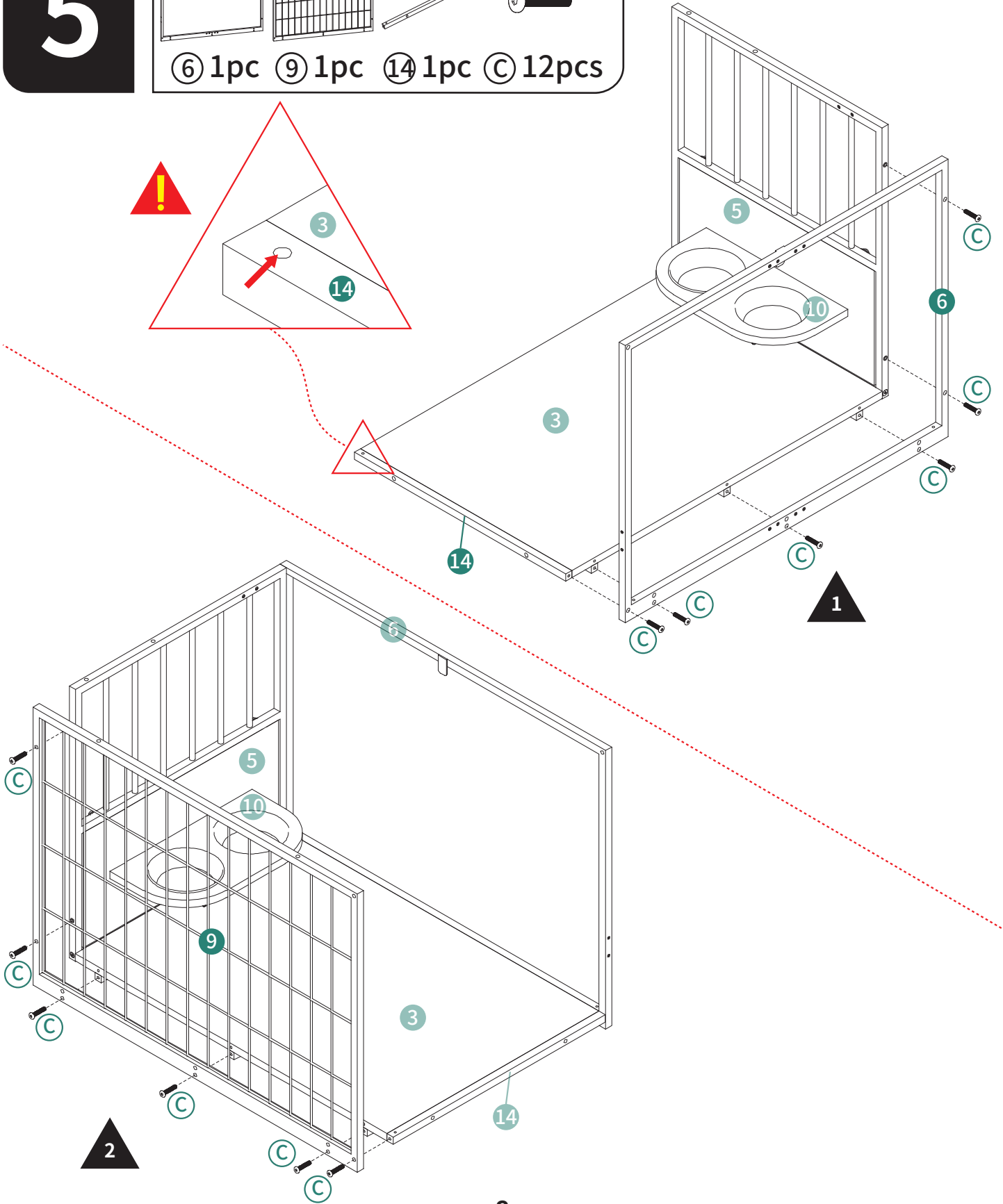
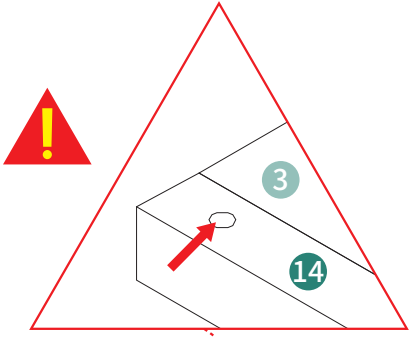

6

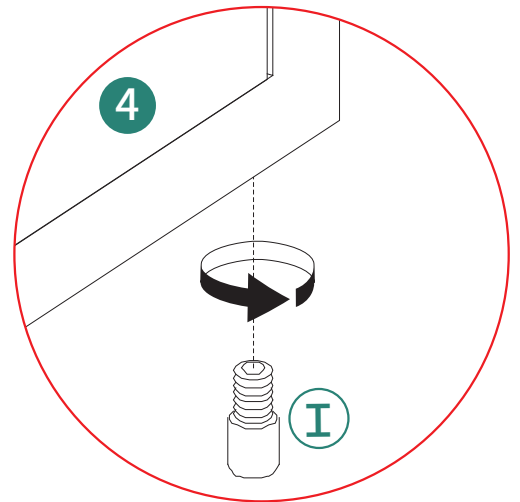
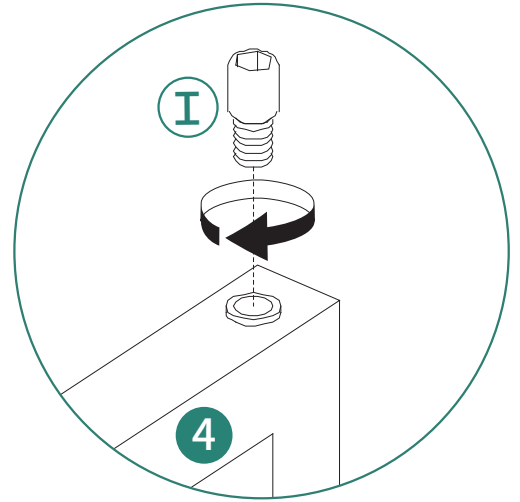
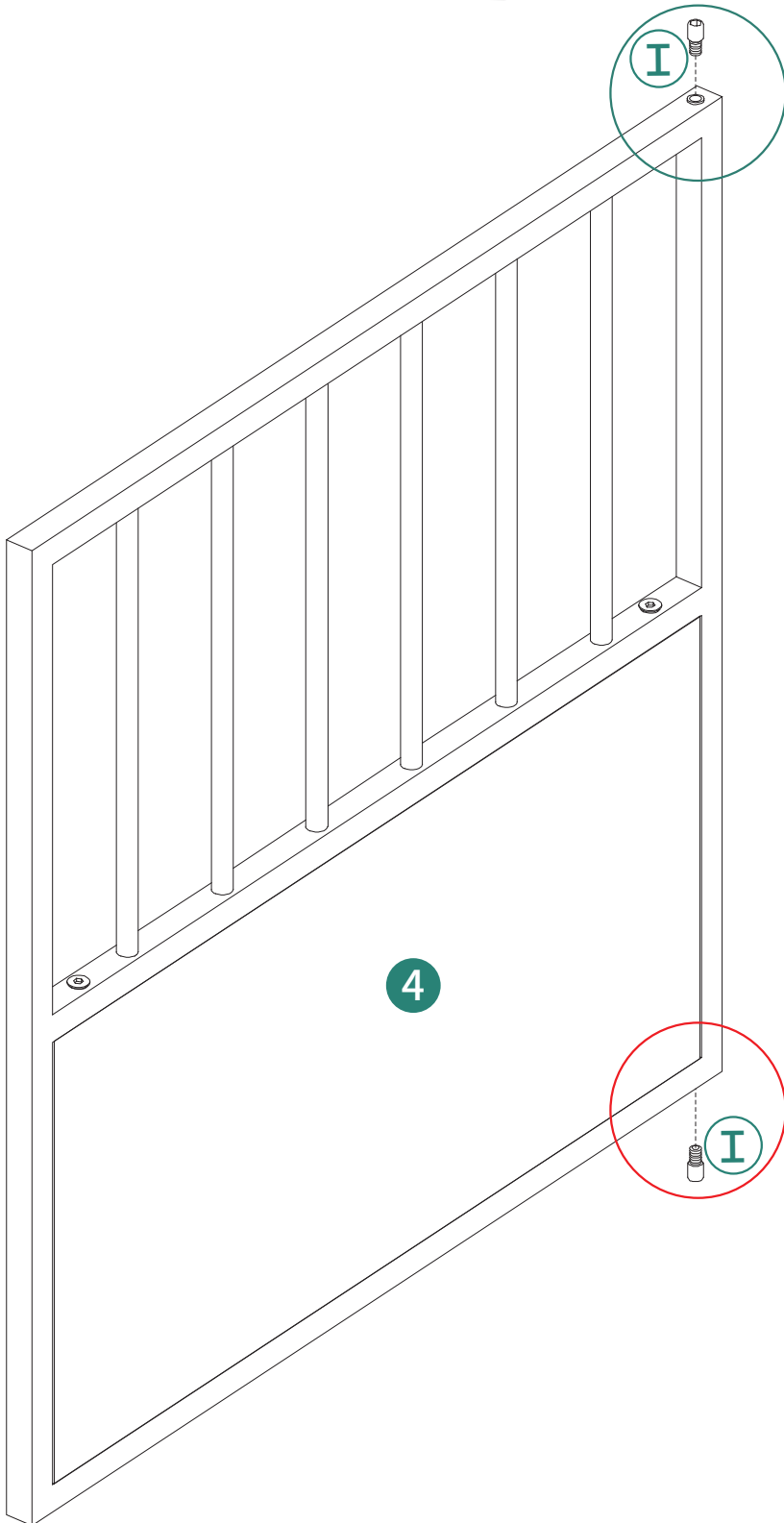
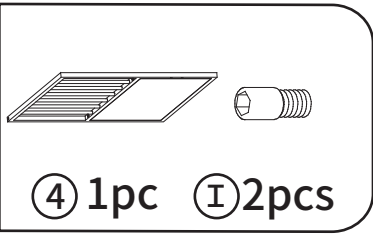

7

metal
Ⓚ 1pc

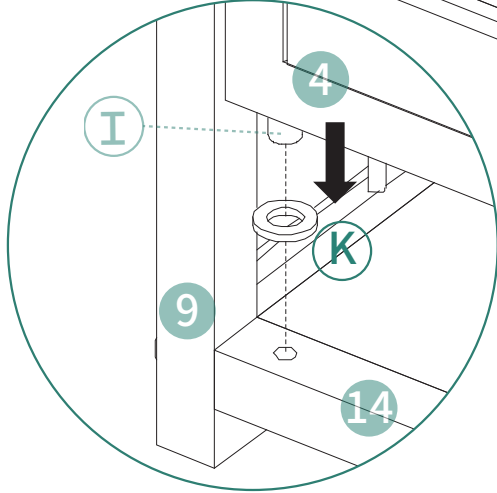
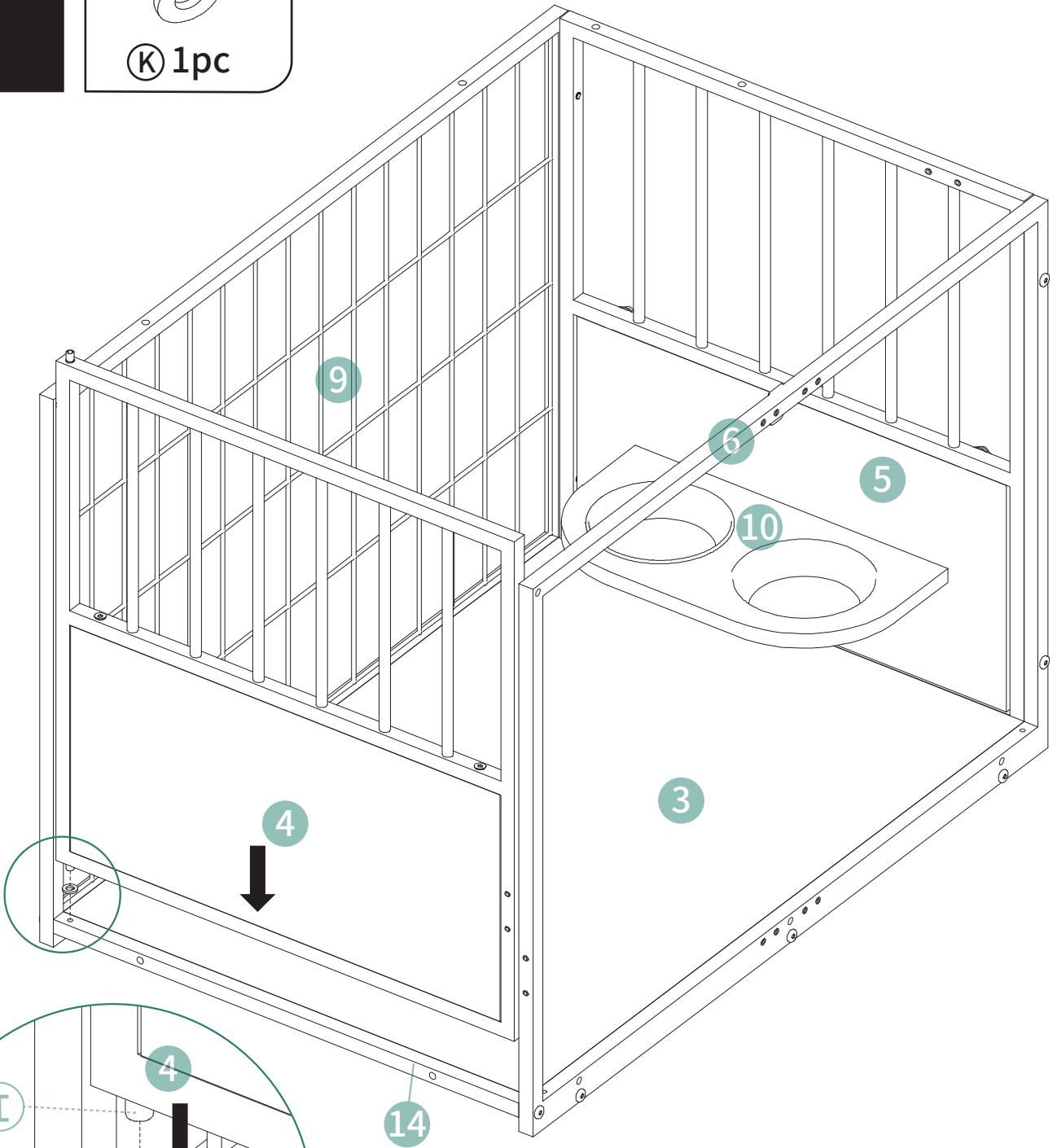

8

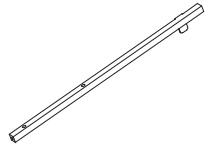

13 1pc C 2pcs

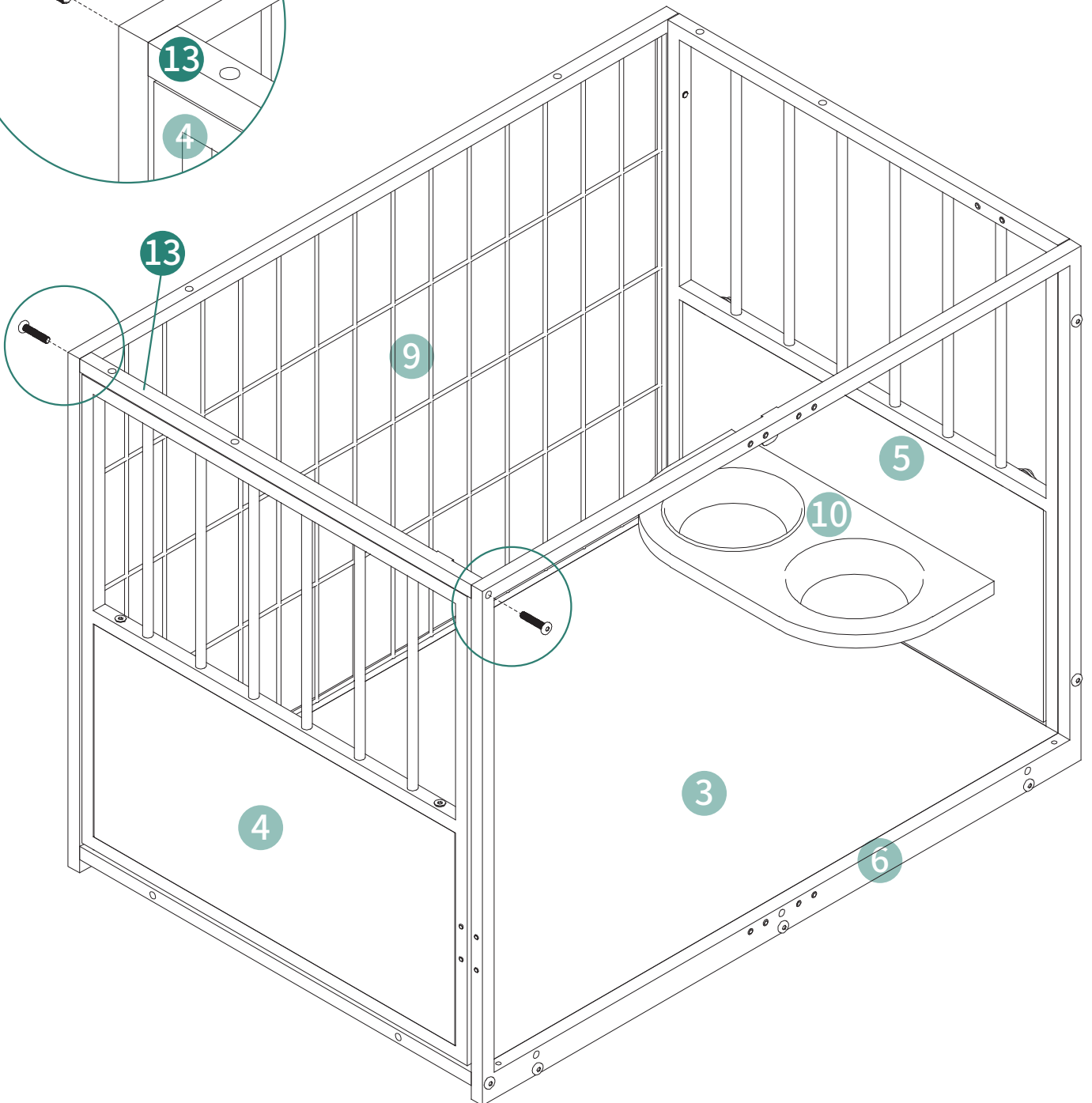
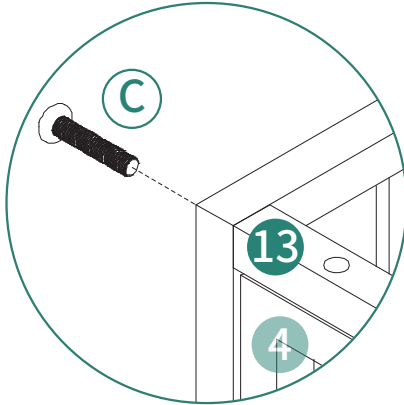

9

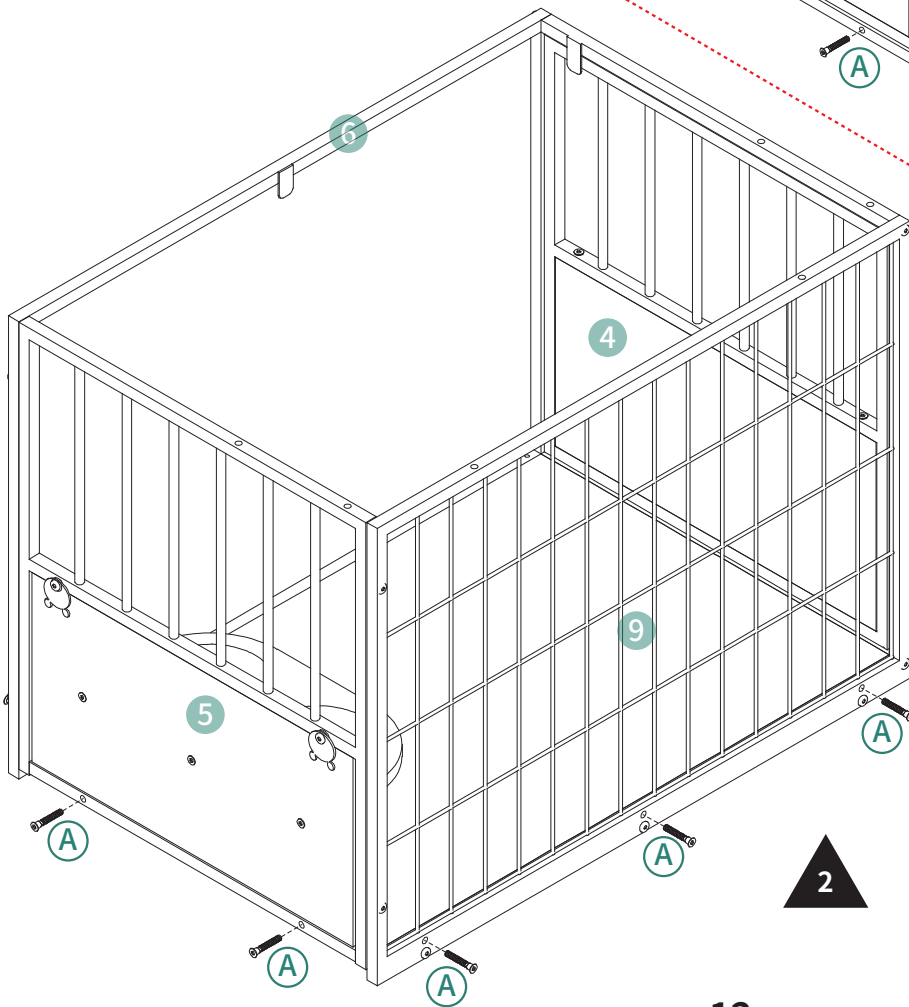
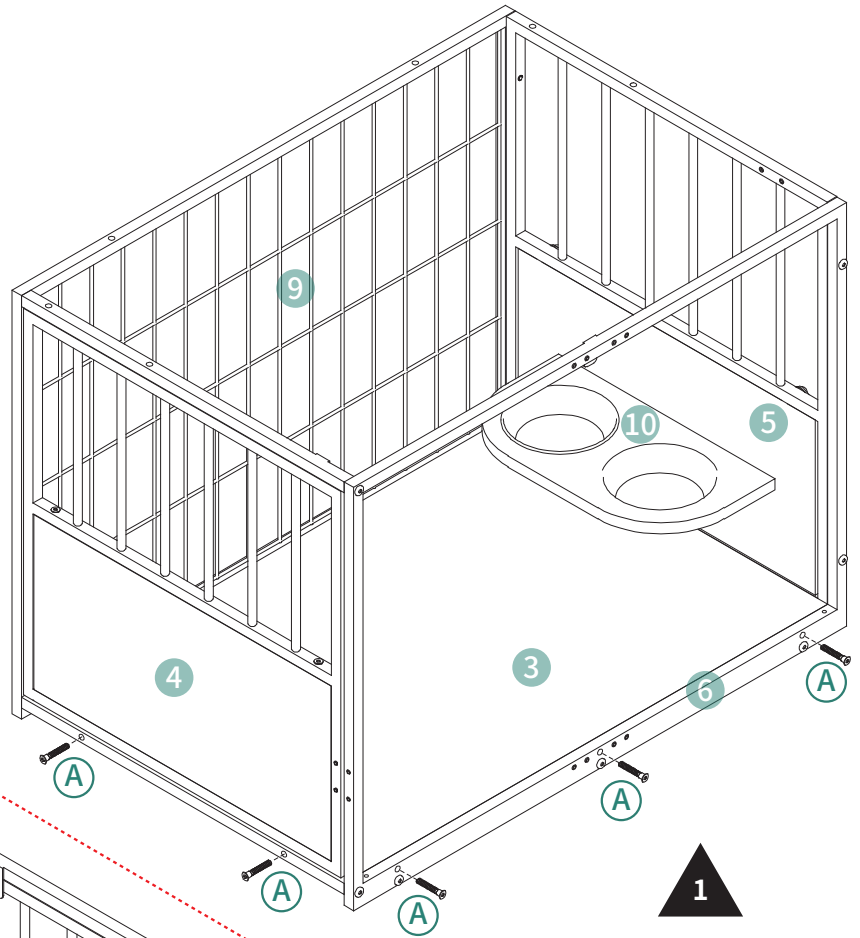
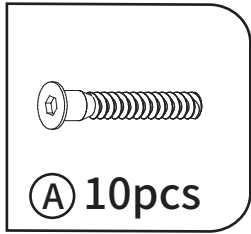

10

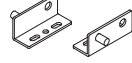
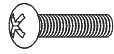
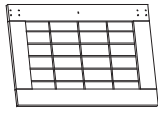

⑦ 2pcs ①F 2pcs ①H 4pcs ①P 2pcs ①S 1pc

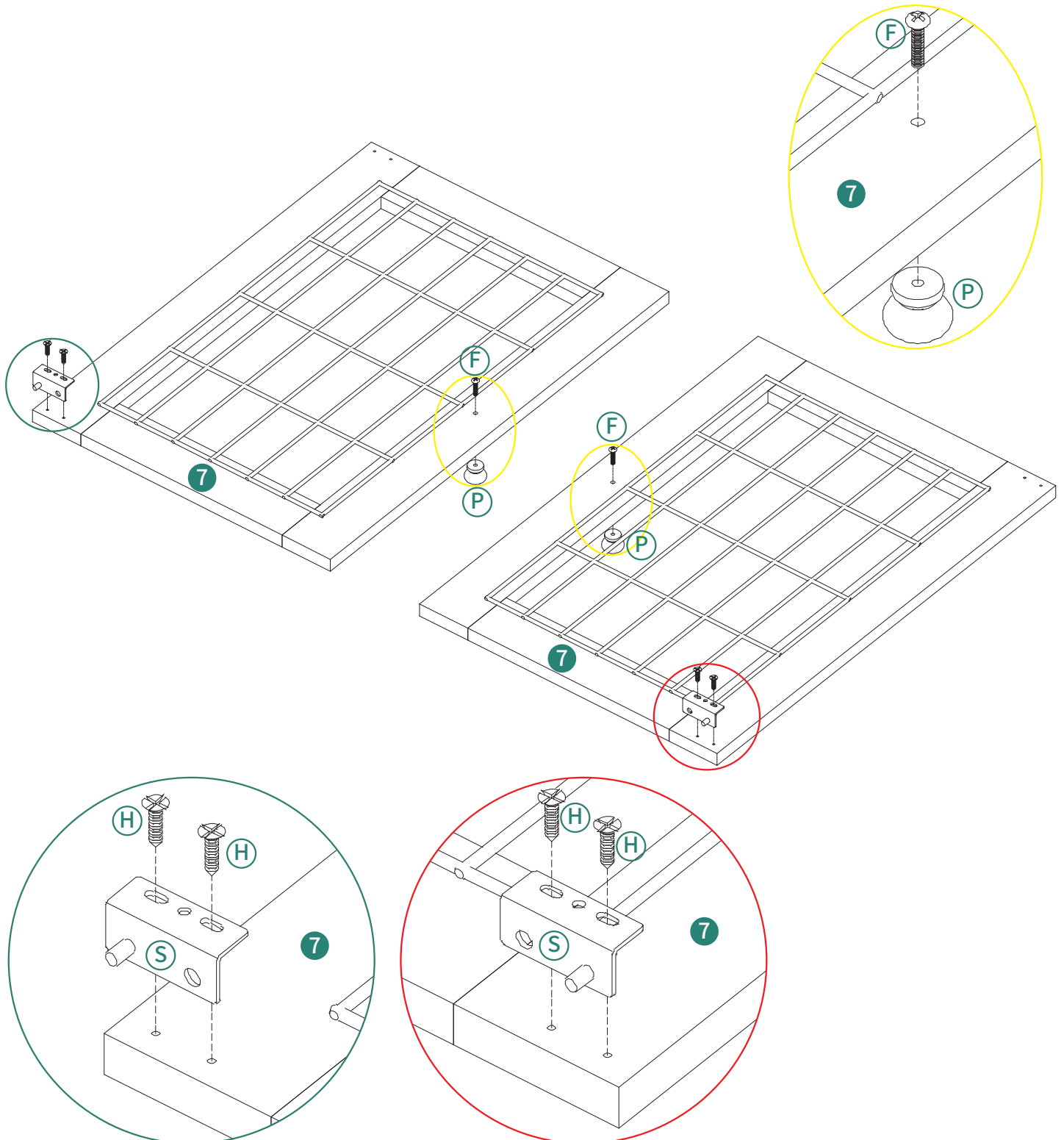

11

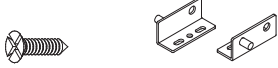

Ⓜ 4pcs Ⓢ 1pc

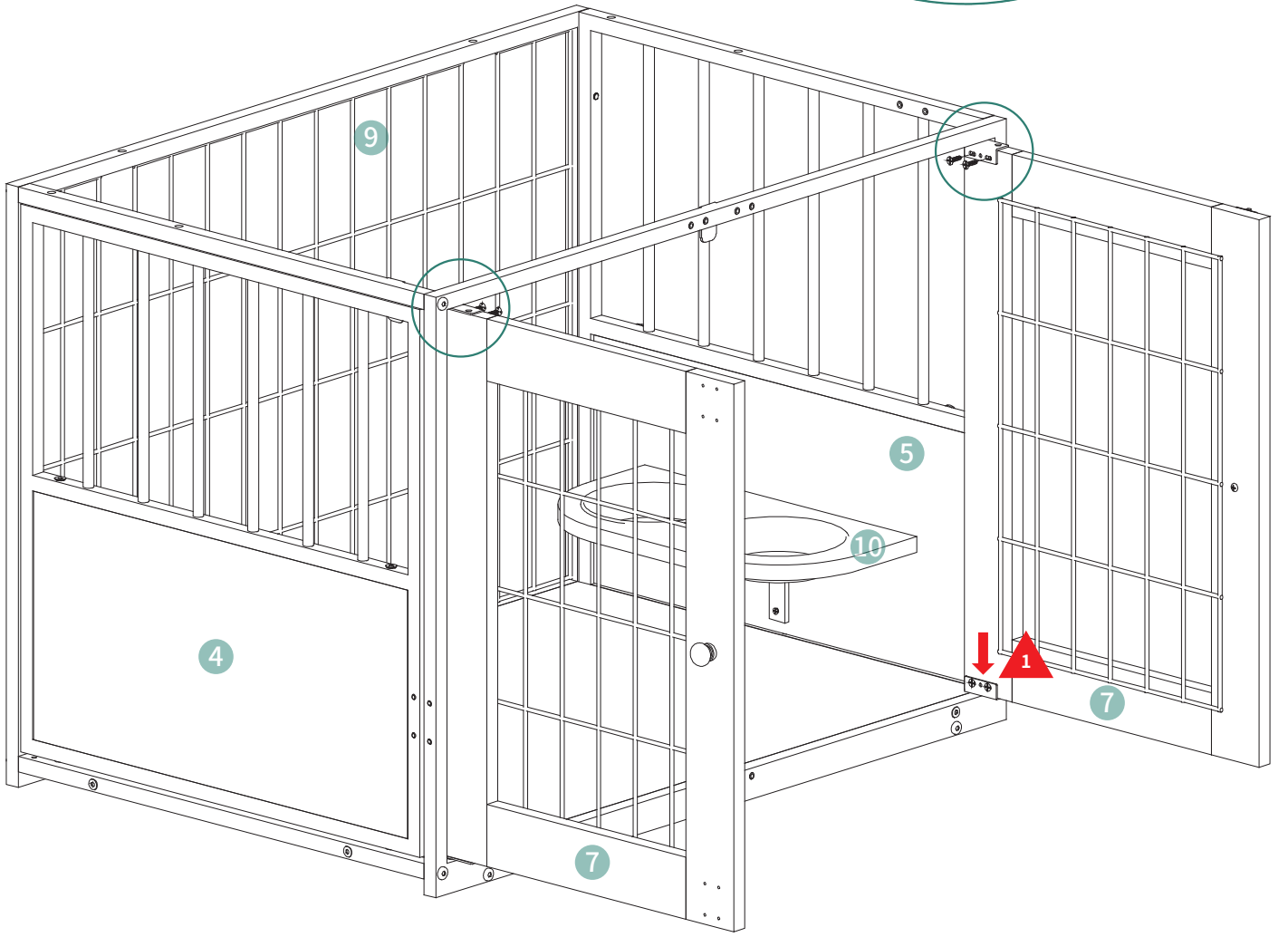
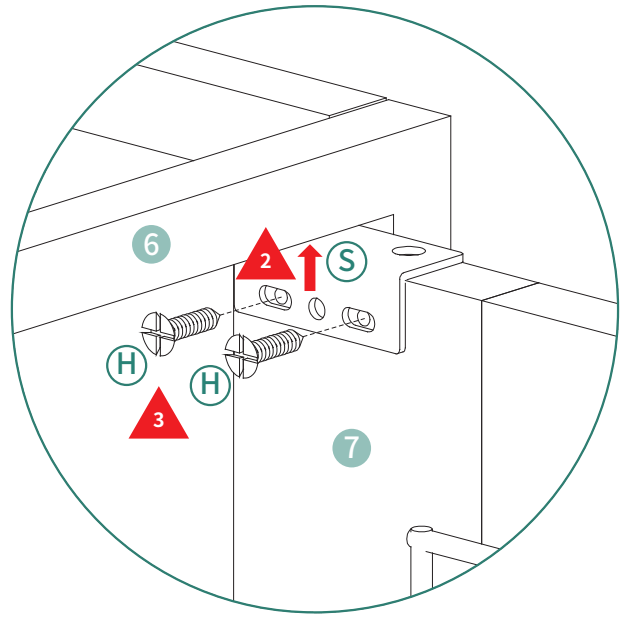

12



ⓔ 8pcs ⓓ 16pcs ⓠ 4pcs

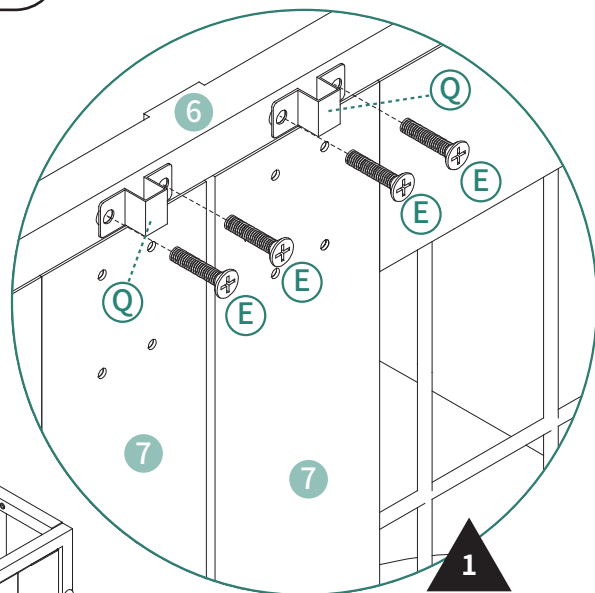
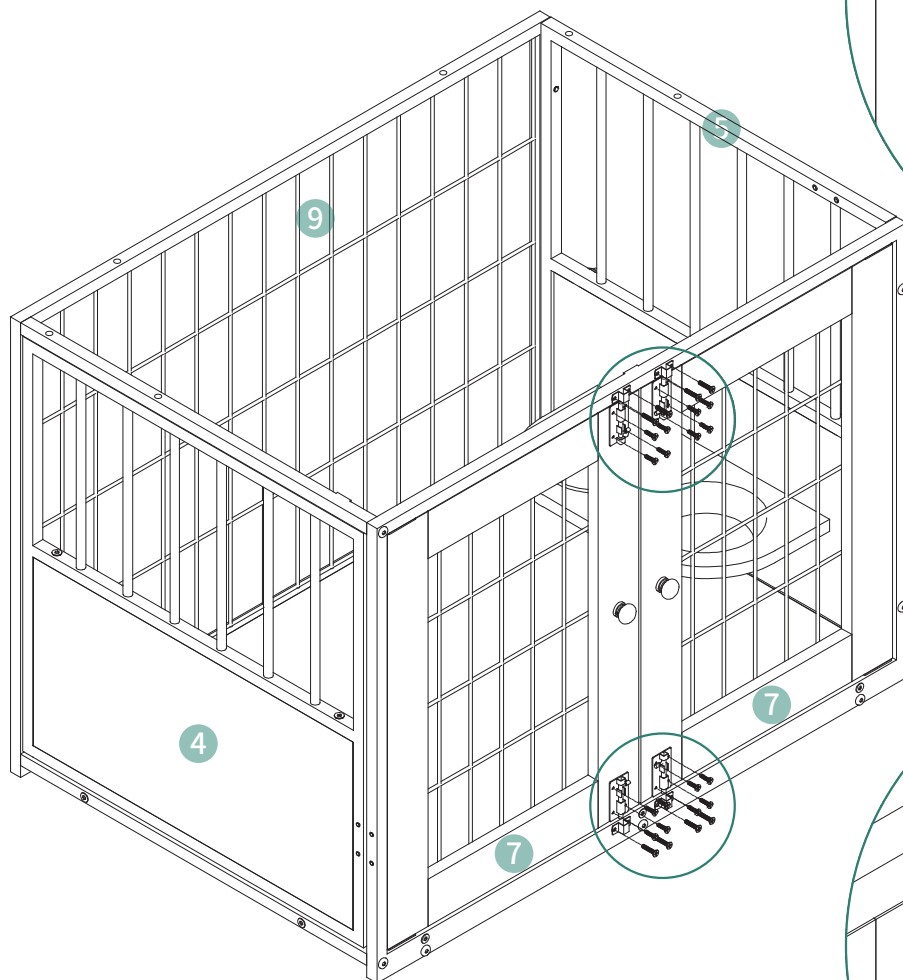

1

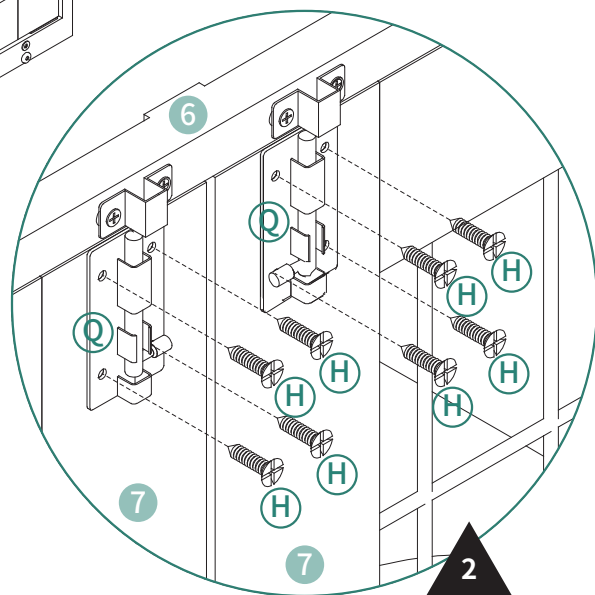

2

13

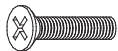

ⓔ 4pcs

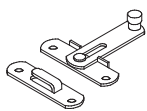

Ⓝ 1pc

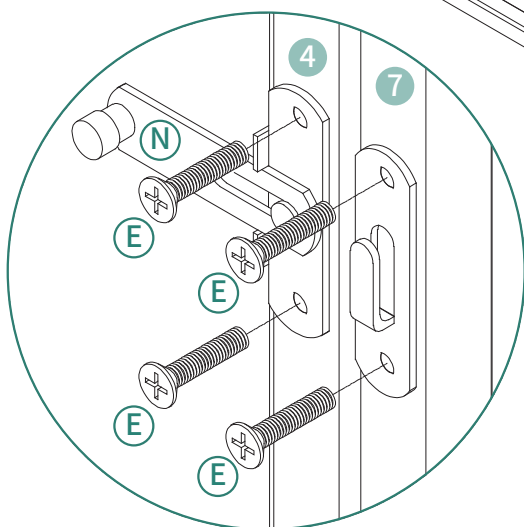
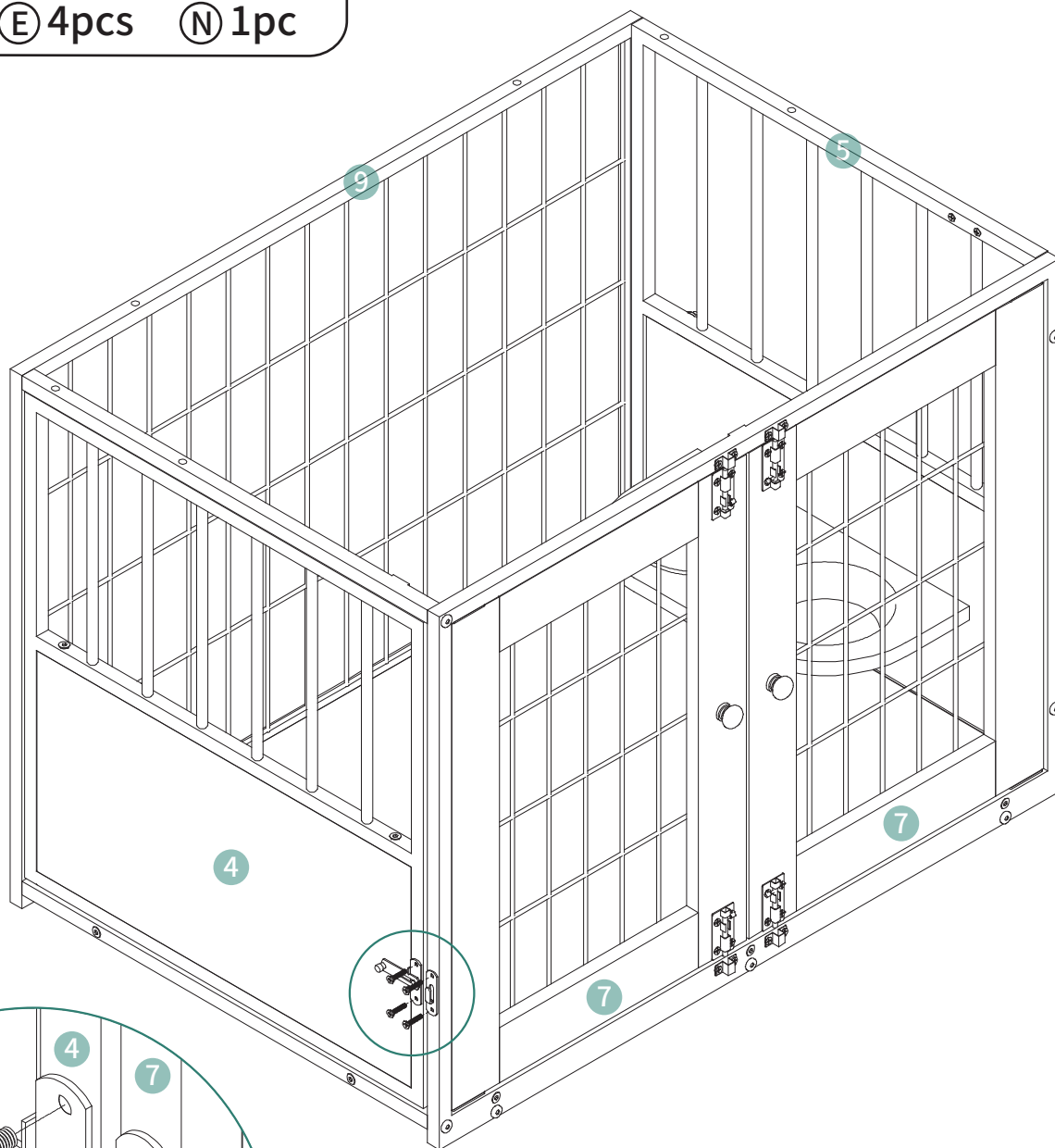

14

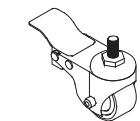

Ⓡ 4pcs

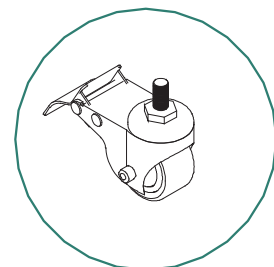
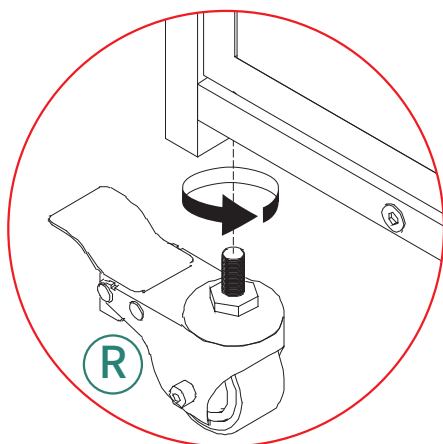
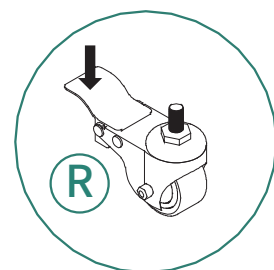
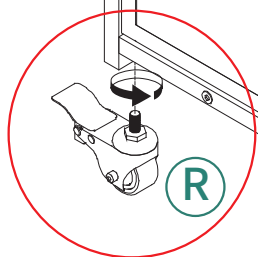
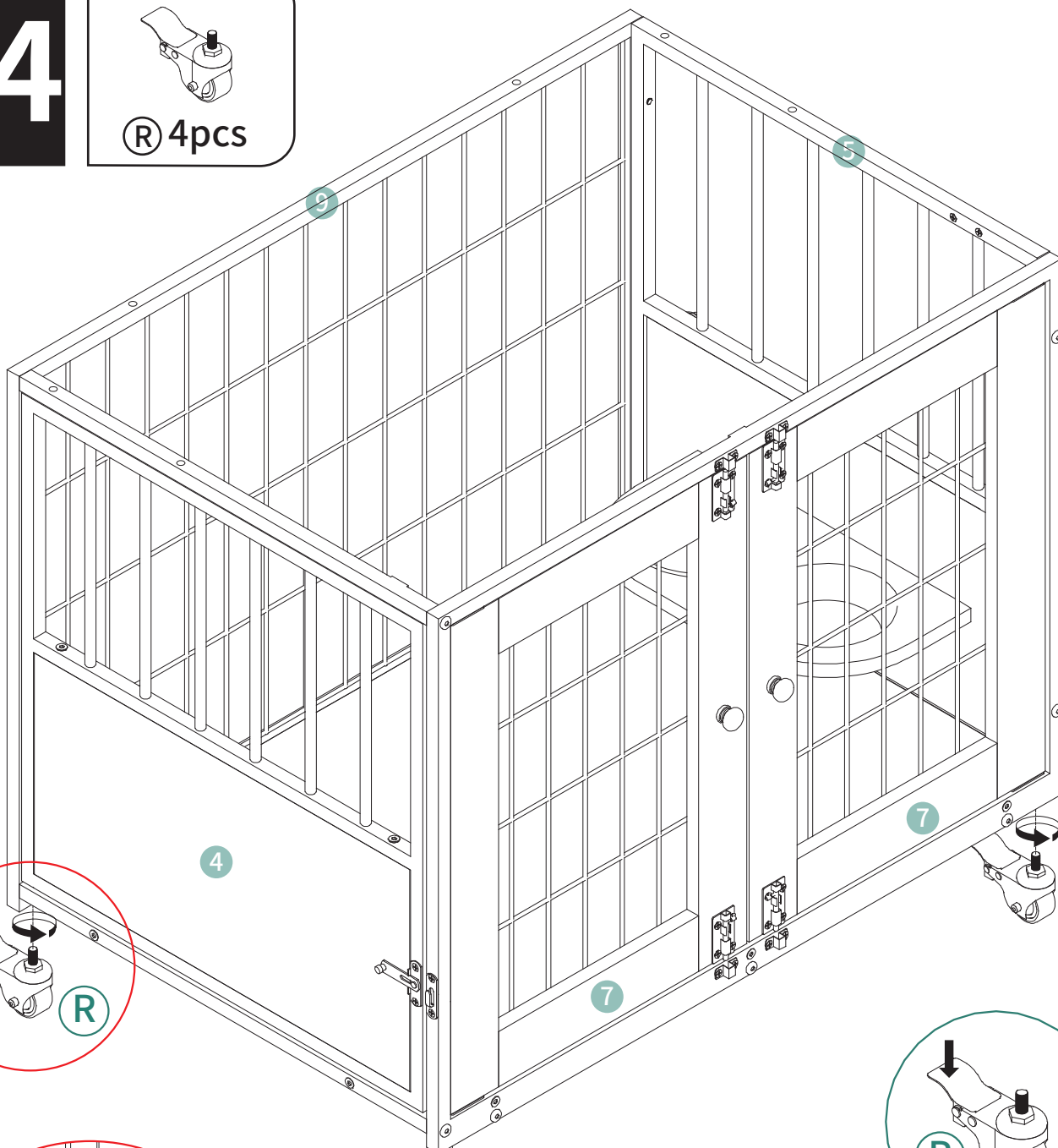

15

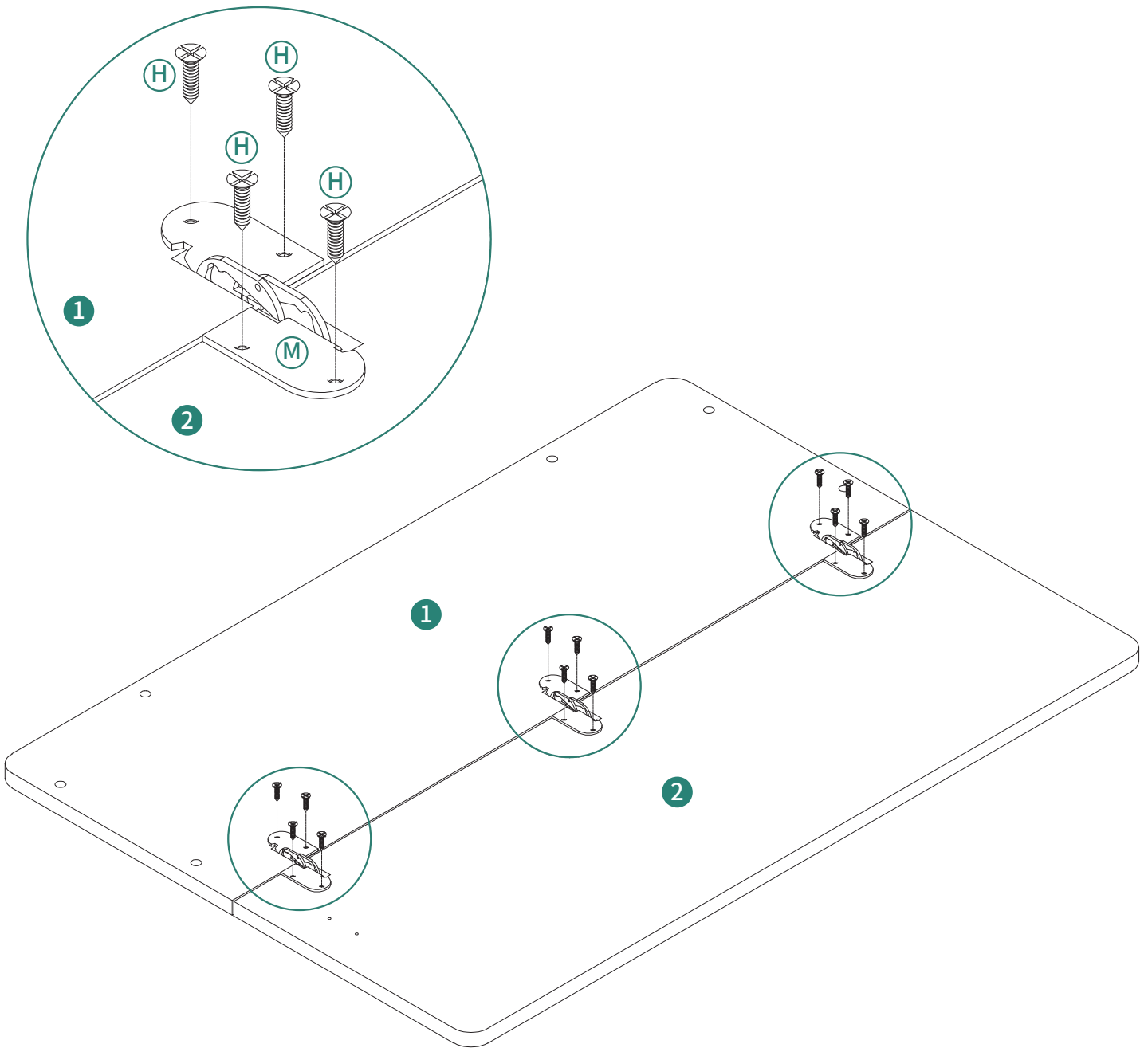
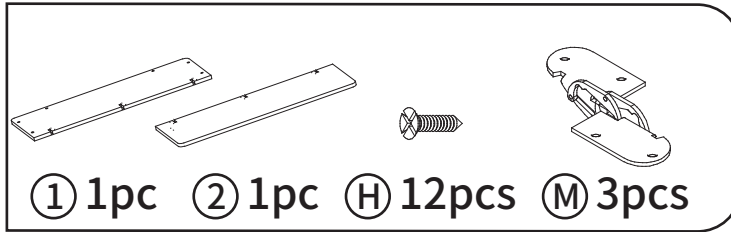

16

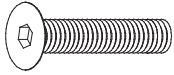

Ⓑ 6pcs

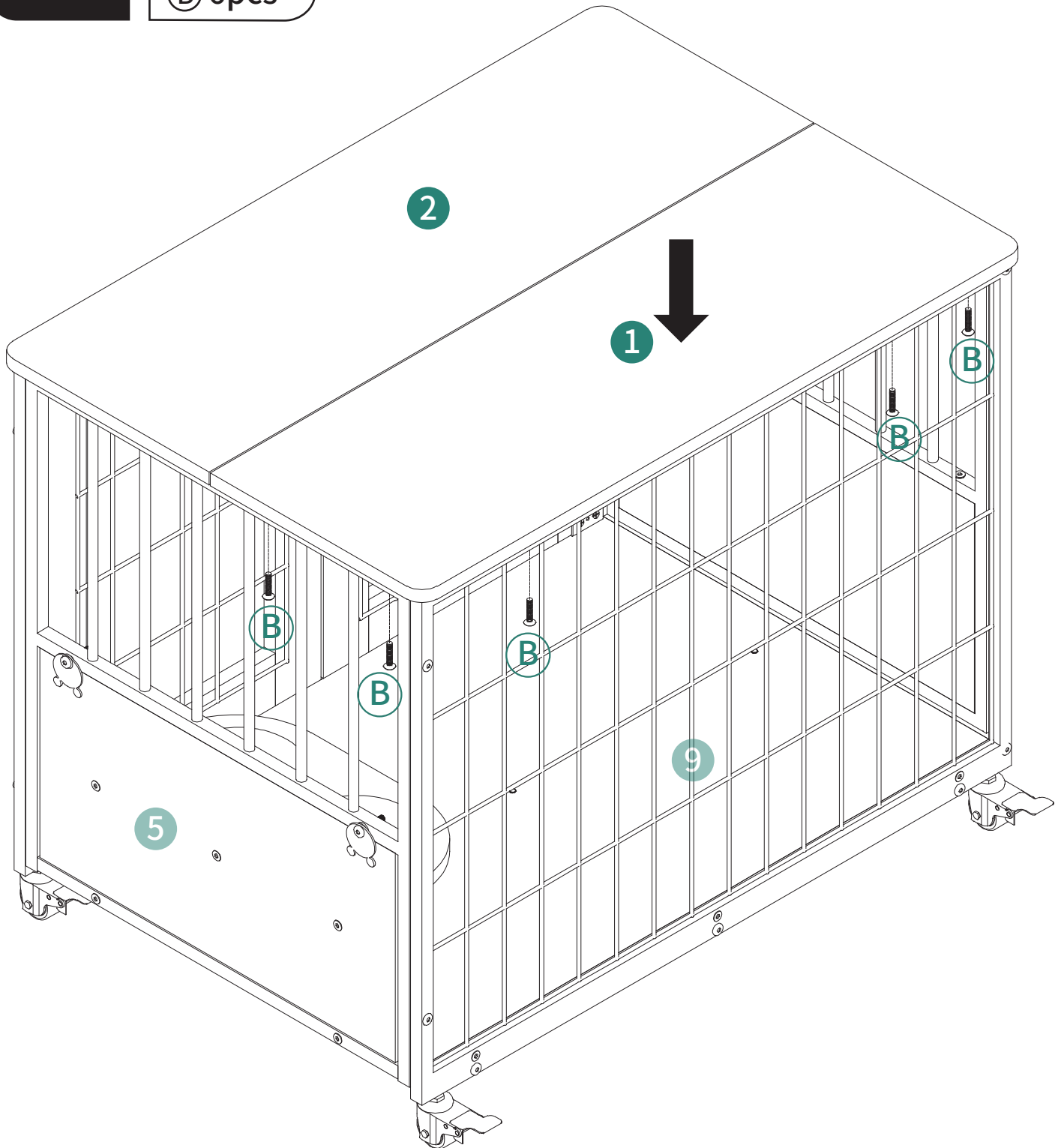

17

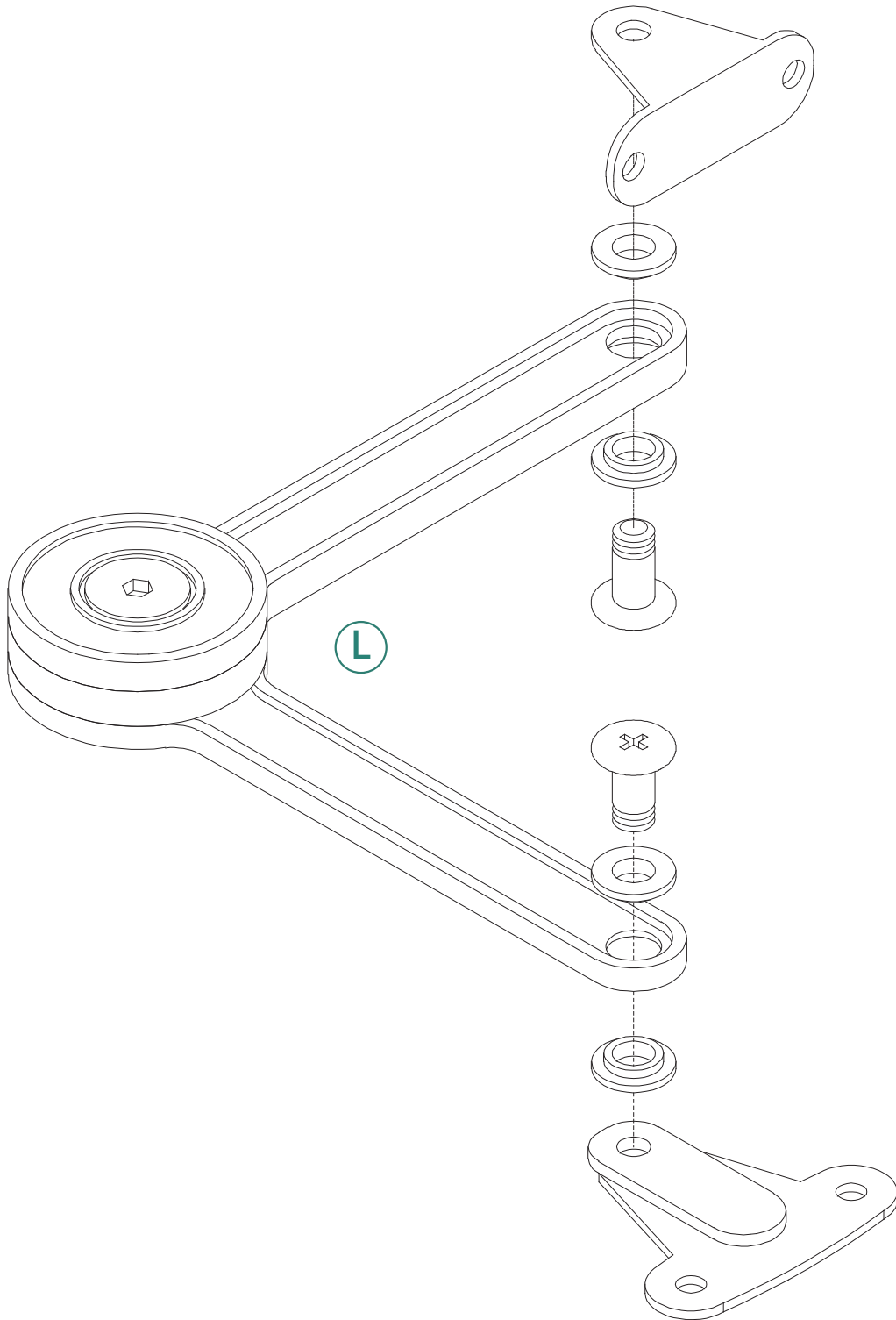
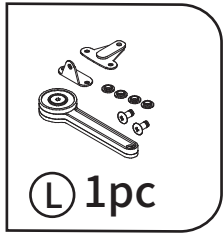

18

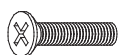

ⓔ 2pcs



ⓓ 2pcs



Ⓣ 3pcs

Tighten or loosen the nut to adjust the tightness of bracing rod.
Ziehen Sie die Mutter fest oder lockern Sie sie, um die Spannung der Abstützstange anzupassen.
Serrez ou desserrez l'écrou pour ajuster la tension de la tige de soutien.
Stringere o allentare l'anello per regolare la tensione dell'asta di supporto.
Apriete o aflojen la tuerca para ajustar la tensión de la barra de refuerzo.

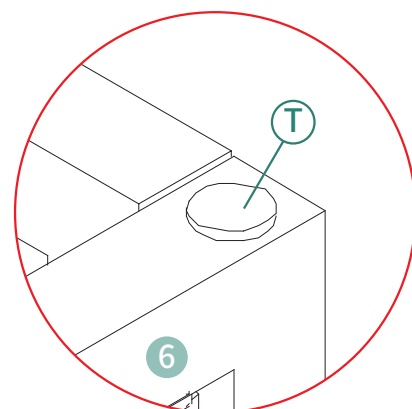
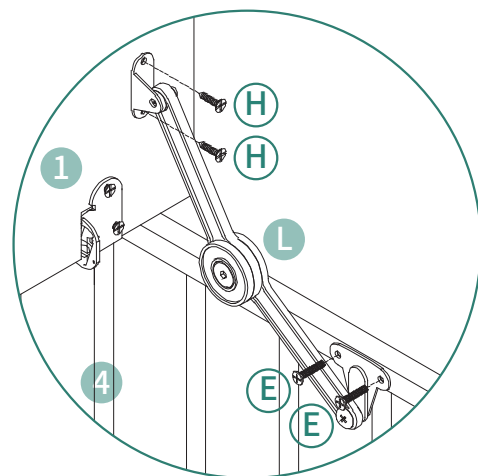
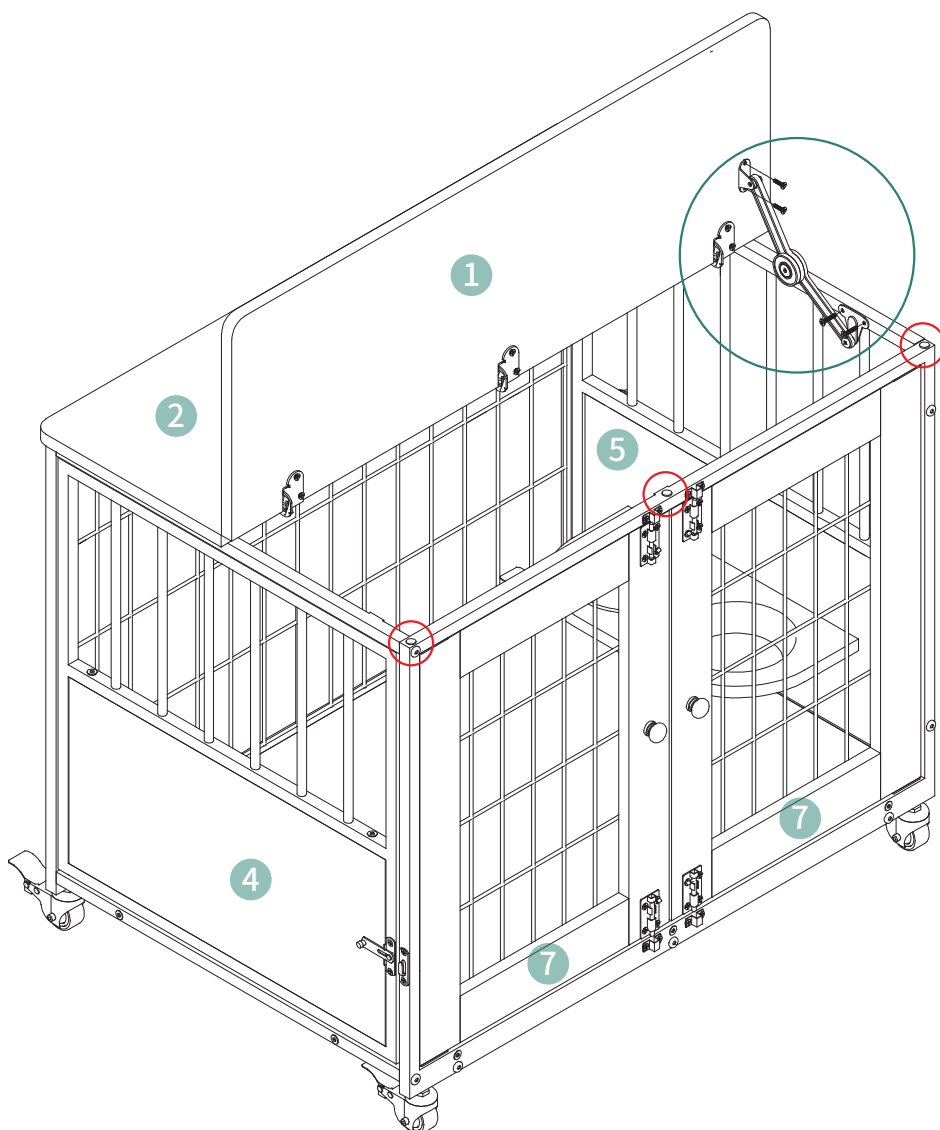
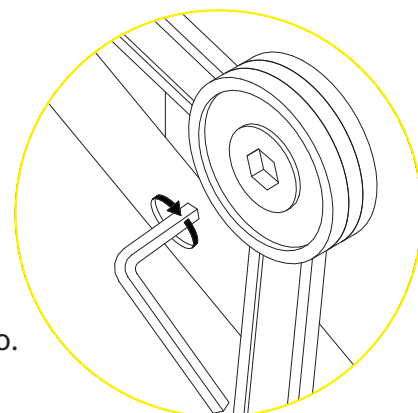

19

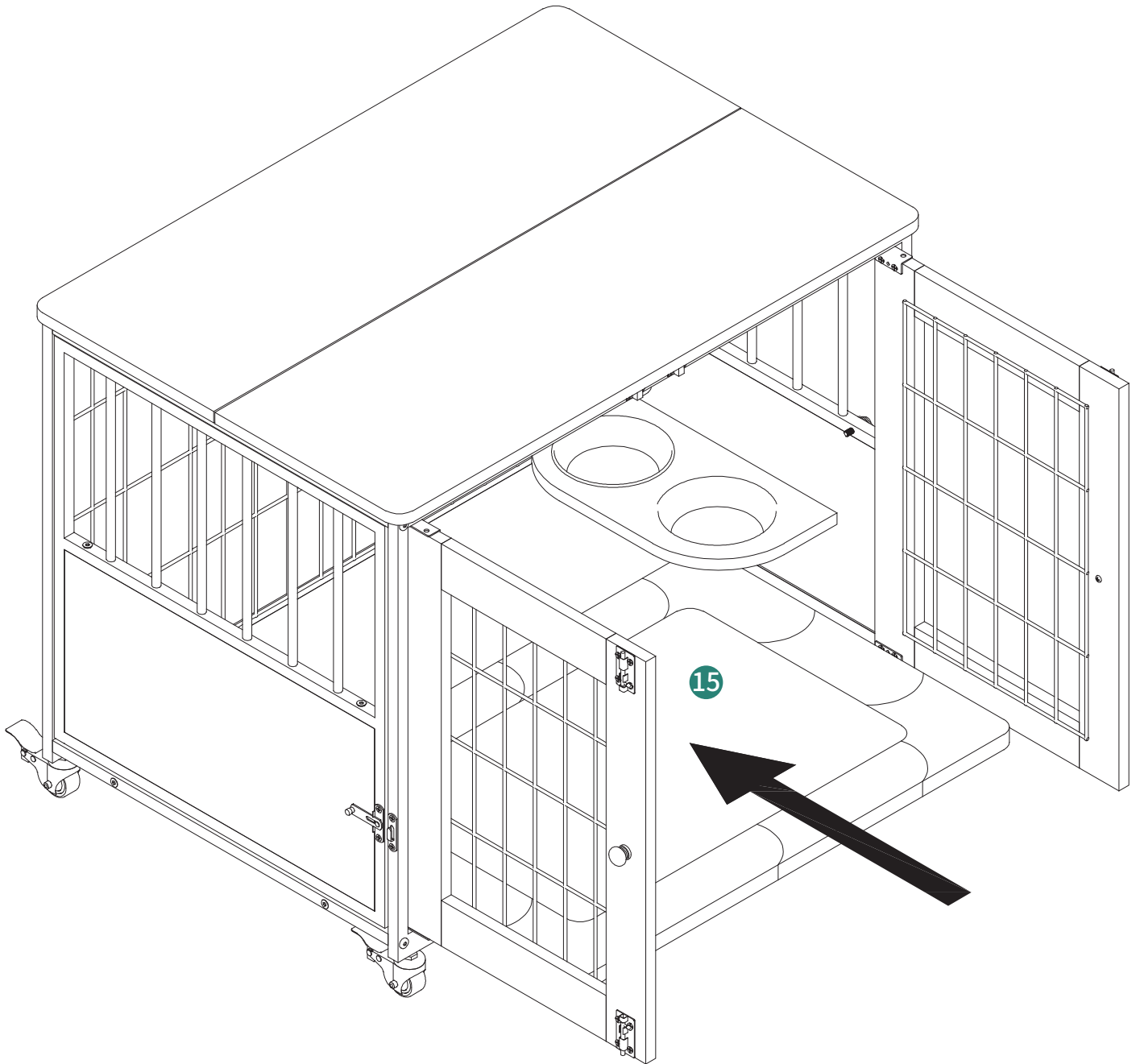
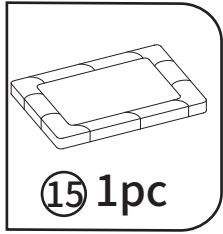

20

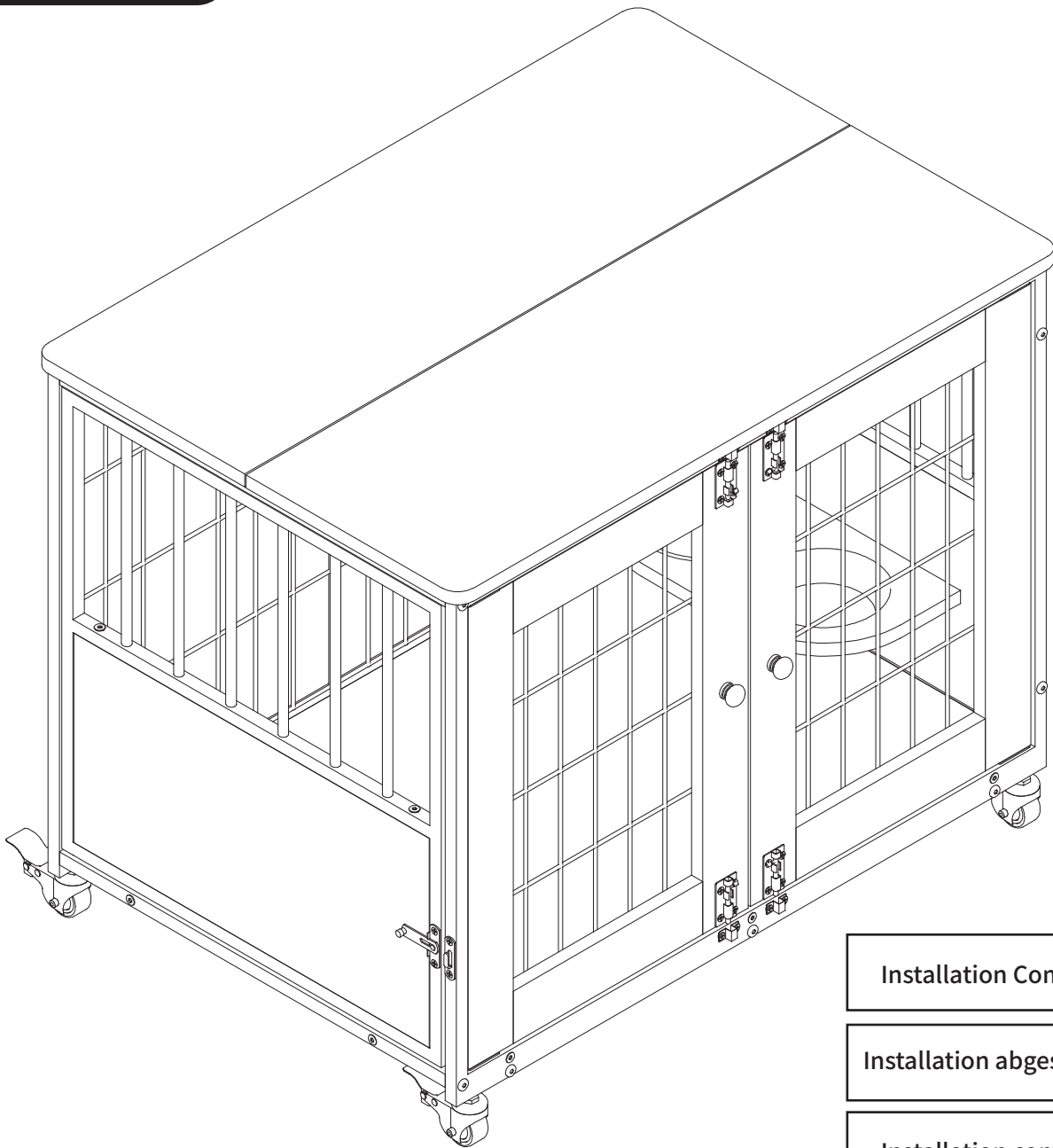

Installation Completed

Installation abgeschlossen

Installation complétée

Installazione completata

Instalación completada