





# LEXINGTON®

## HOME BRANDS

### ASSEMBLY INSTRUCTIONS

725-875B Rendezvous Round Dining Table with Wood Top or Glass Top

#### HARDWARE PACK 99-8-725-875WDAH

A		Allen Wrench	1 Pc
B		Lock Washer	7 Pcs
C		Flat Washer	7 Pcs
D		Joint Connector Bolt 8 x 50mm ( $\frac{5}{16}$ x 2")	7 Pcs

#### HARDWARE PACK 99-8-725-875GLBP

E		Clear Rubber Bumper	7 Pcs
---	---	---------------------	-------

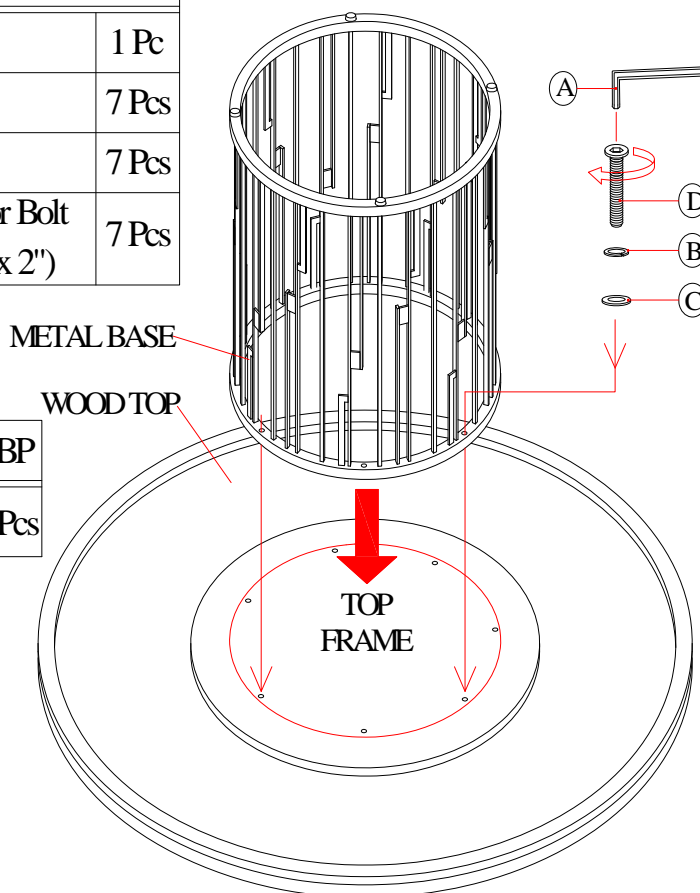
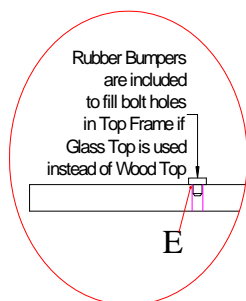

#### **To Assemble Table with Wood Top (725-875T), use Hardware Pack 99-8-725-875WDAH:**

1. Place wooden table top upside-down on flat, clean, non-marring surface.
2. Position metal base on table top so that holes in metal base align with holes in top frame.
3. Use Allen Wrench (A) to attach metal base to top frame with (7) of each: flat washers (C), lock washers (B), and joint connector bolts (D). Securely tighten hardware.
4. Return assembled table to its upright position and place in desired location.

#### **To Assemble Table with Glass Top (001-060GT or 001-072GT), use Hardware Pack 99-8-725-875GLBP:**

1. Place metal base in desired location.
2. Insert a rubber bumper (E) into each of the (7) bolt holes on top frame of metal base.
3. Carefully lay glass top on base so that glass is centered and rests on the bumpers.

For additional consumer assistance please contact your Lexington dealer or call our Customer Services Department at 1-336-474-5300, Monday-Friday, 8-5 Eastern