

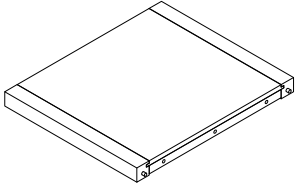

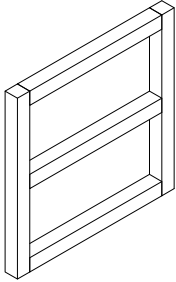

# Assembly Instructions

## END TABLE

### Parts and Tools

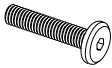
A	51031196-A		X 2	<p><b>Before beginning</b></p> <p>1) Carefully unpack and position the item on a clean, non-marring surface to assemble.</p> <p>2) Read this Assembly Instructions from beginning to end before starting to assemble.</p> <p>3) Take an inventory of the required parts to ensure all are available.</p> <p>4) To prevent accidental choking hazards, keep all packing materials away from small children.</p>	
B	51031196-B		X 2		
Z	51031196-Z	<p>Z1</p>  <p>4 mm x1</p>	<p>Z2</p>  <p>6x35 mm x12</p>	<p>Z3</p>  <p>6 mm x12</p>	<p>Z4</p>  <p>6 mm x12</p>

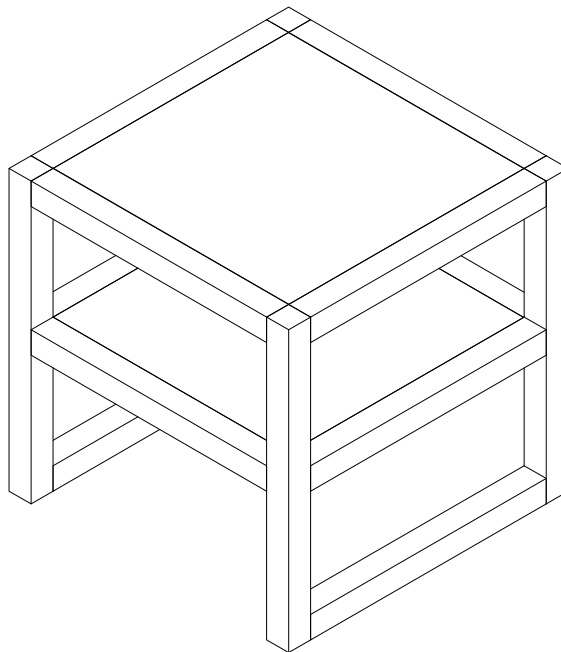

ASSEMBLY REQUIRES  
TWO PEOPLE



15 MINUTE  
ASSEMBLY TIME



KEEP INSTRUCTIONS  
FOR FUTURE USE

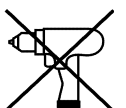

# Assembly Instructions

## END TABLE

1

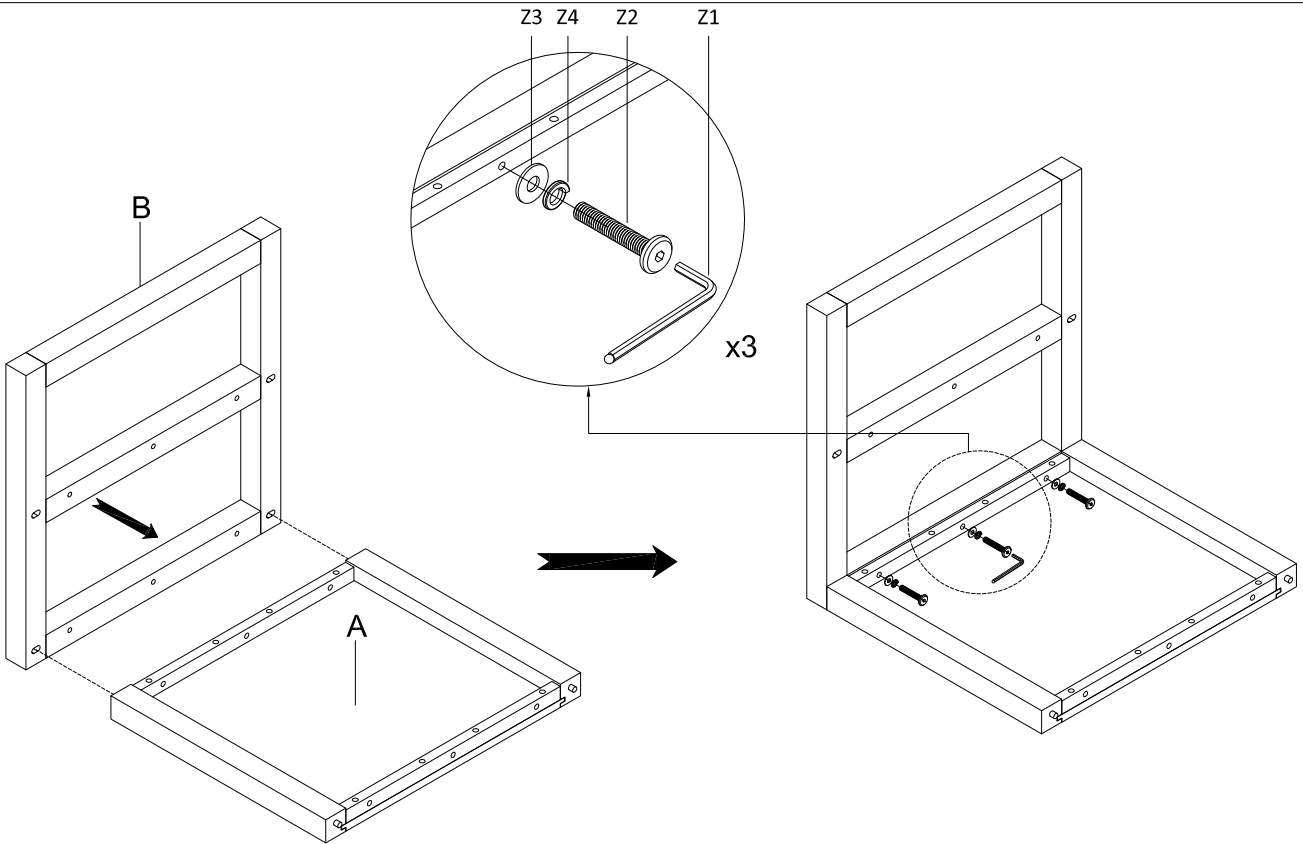

2

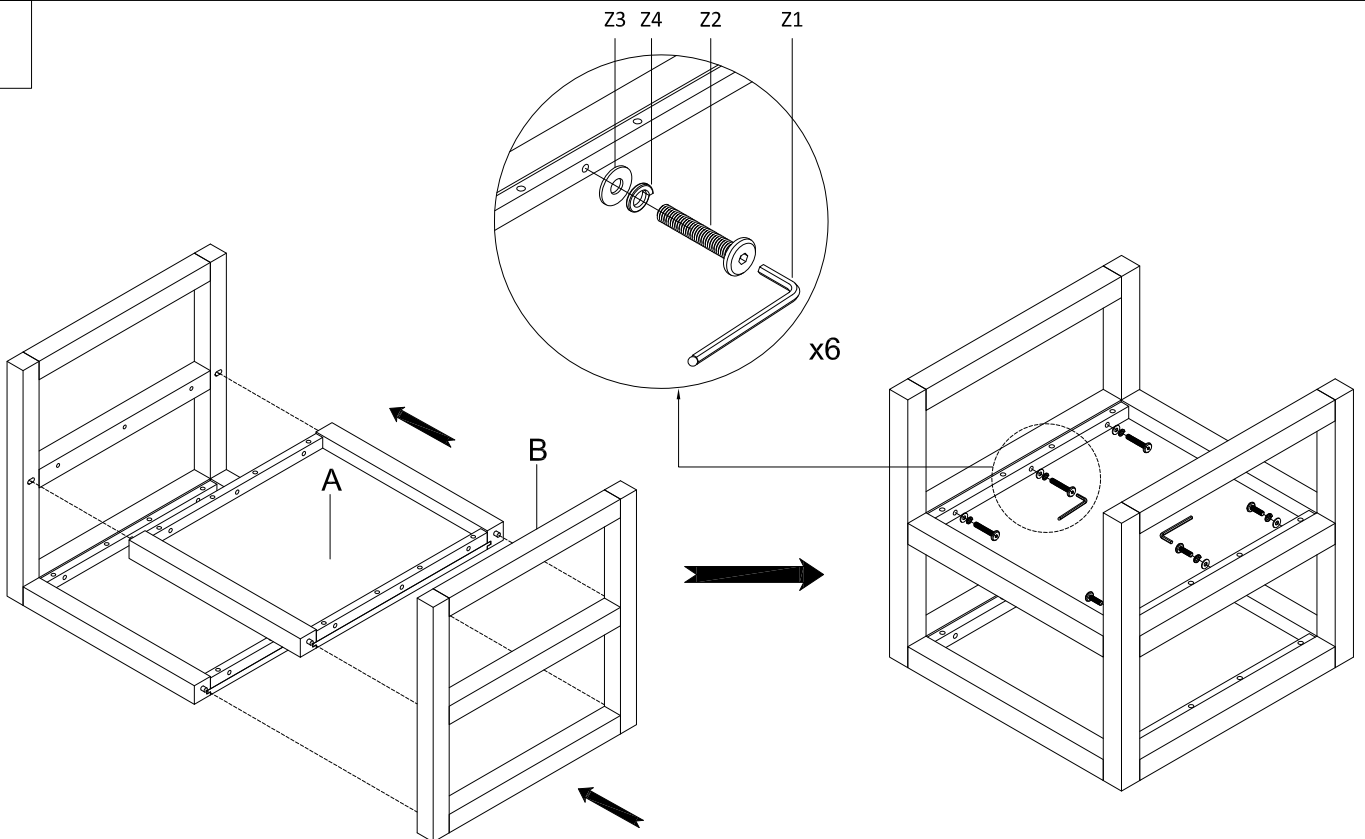

# Assembly Instructions

## END TABLE

3

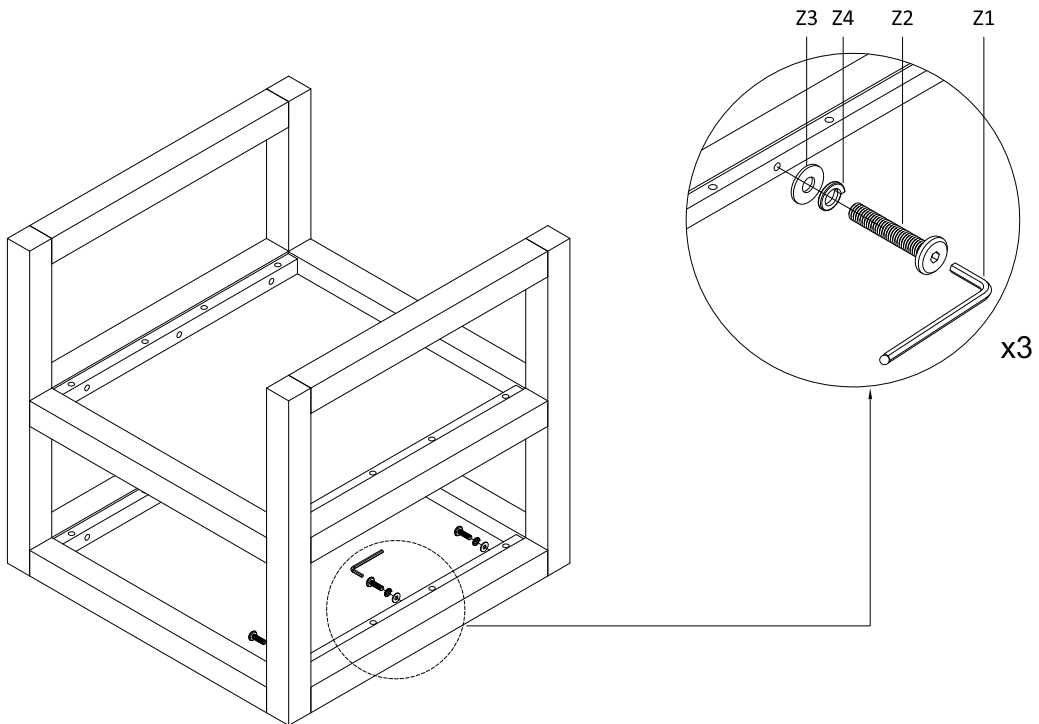

4

