

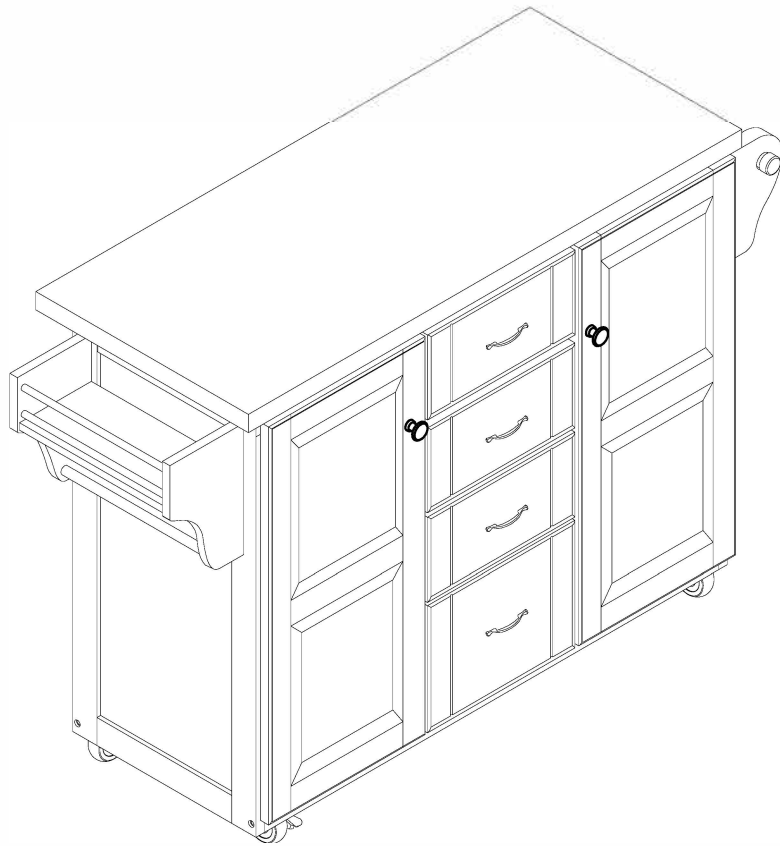

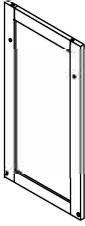

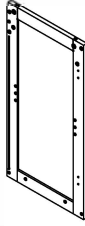

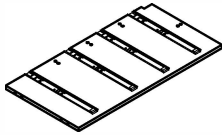

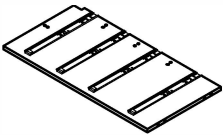
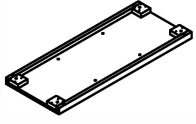
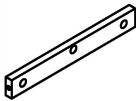

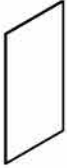

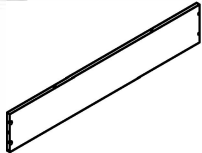

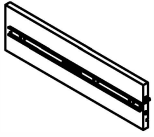
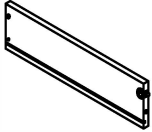
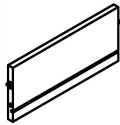
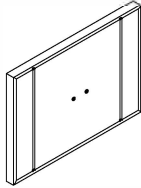
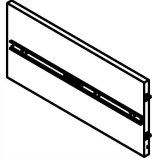
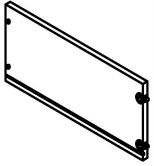
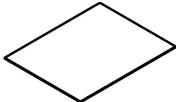
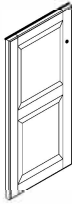
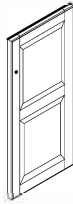

Kitchen Cart





PART LIST

<p>A</p> <p><i>O</i></p>	<p>B</p> 	<p>C</p> 	<p>D</p> 	<p>E</p> 
<p>Top Panel 1 PC</p>	<p>Left Side Panel 1 PC</p>	<p>Right Side Panel 1 PC</p>	<p>Left Partition Panel 1 PC</p>	<p>Right Partition Panel 1 PC</p>
<p>F</p> 	<p>G</p> 	<p>H</p> 	<p>I</p> 	<p>J</p> 
<p>Bottom Panel 1 PC</p>	<p>Top Rail 1 PC</p>	<p>Front Rail 2 PCS</p>	<p>Front Middle Rail 1 PC</p>	<p>Back Panel 3 PCS</p>
<p>K</p> 	<p>L</p> 	<p>M</p> 	<p>N</p>	<p>O</p> 
<p>Back Rail 2 PCS</p>	<p>Back Top Rail 1 PC</p>	<p>Front Top Rail 1 PC</p>	<p>Top Drawer Front Panel 3 PCS</p>	<p>Top Drawer Left Side Panel 3 PCS</p>
<p>p</p> 	<p>Q</p> 	<p>R</p> 	<p>S</p> 	<p>T</p> 
<p>Top Drawer Right Side Panel 3 PCS</p>	<p>Top Drawer Back Panel 3 PCS</p>	<p>Bottom Drawer Front Panel 1 PC</p>	<p>Bottom Drawer Left Side Panel 1 PC</p>	<p>Bottom Drawer Right Side Panel 1 PC</p>
<p>u</p> <p><i>c)</i></p>	<p>V</p> 	<p>W</p> 	<p>X</p> 	<p>y</p> 
<p>Bottom Drawer Back Panel 1 PC</p>	<p>Drawer Bottom Panel 4 PCS</p>	<p>Left Door Panel 1 PC</p>	<p>Right Door Panel 1 PC</p>	<p>Towel Bar Left Side Panel 1 PC</p>

PART LIST

		@J 	<i>m</i> 	<i>m</i> 
Towel Bar Right Side Panel 1 PC	Towel Bar Support Panel 1 PC	Large Support Bar 1 PC	Small Support Bar 2 PCS	Small Towel Bar Panel 2 PCS
<u>ZEI</u> 	<i>m</i> 	<u>ZGI</u>	<u>ZHI</u> 	
Small Towel Bar 1 PC	Adjustable Shelf 2 PCS	Locking Caster 2 PCS	Caster 2 PCS	

HARDWARE LIST

#1	#2	#3	#4	#5
08*30mm	06*30mm)
Large Wood Dowel 42 PCS (Extra 1)	Small Wood Dowel 12 PCS (Extra 1)	Cam Bolt 7 PCS (Extra 1)	Cam Lock 7 PCS (Extra 1)	Handle 4 PCS
#6	#7	#8	#9	#10
	3/4"*05/32"*D9mm			
Knob 2 PCS	Round Head Bolt 10 PCS (Extra 1)	Barrel Nut 4 PCS	Bolt 14 PCS (Extra 1)	Shelf Holder 8 PCS (Extra 1)
#11	#12	#13	#14	#15
	T		!)
Magnet 2 PCS	Small Round Head Screw 20 PCS (Extra 1)	Door Hinge 4 PCS	Large Round Head Screw 16 PCS (Extra 1)	Allen Wrench 1 PC

ADDITIONAL TOOLS (Not Provided)

Note: It is not recommended to use power tools during assembly.

/ Phillips Head Screwdriver

Please do not use tools to assemble this unit unless specifically indicated.

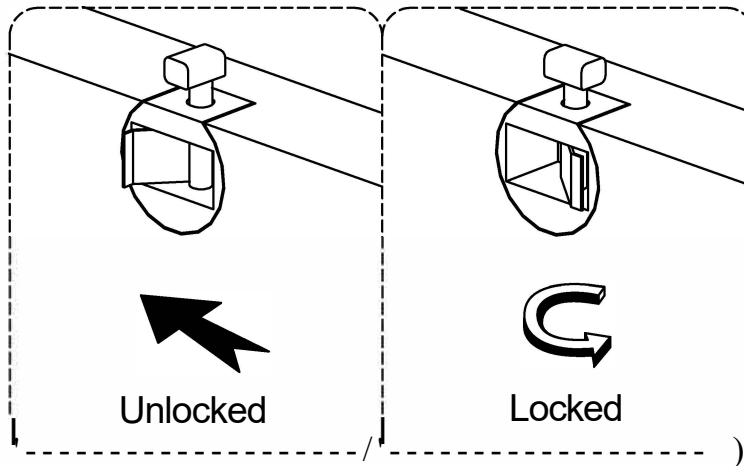

Reference the images above any time the instructions state "lock the hardware".
 Note: Be sure to check all hardware is locked when completed.

Note: Wood dowels are intended for alignment. Additional clearance between wood dowel and pre-drilled hole is intentional for ease of assembly.

Step 1. Attach handles (part #5) to top drawer front panel (part N) and bottom drawer front panel (part R) using round head bolts (part #7) and phillips head screwdriver. Attach knobs (part #6) to left door panel (part W) and right door panel (part X) using round head bolts (part #7) and phillips head screwdriver.

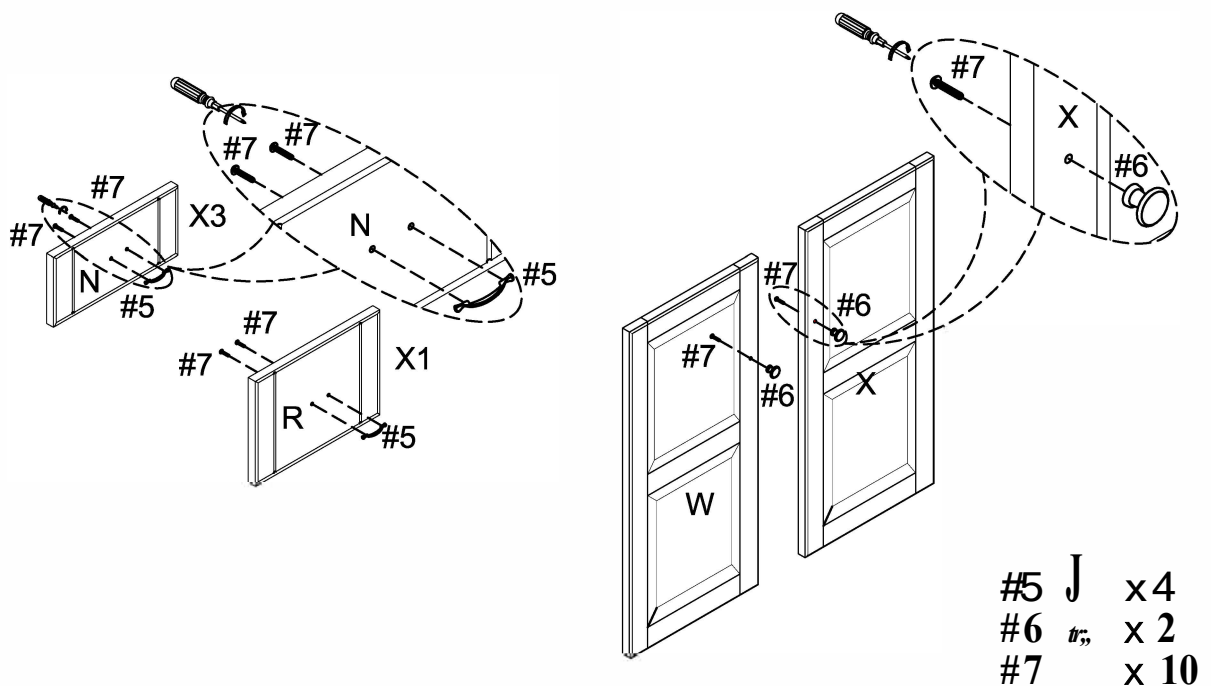

Step 2. Attach door hinges (part #13) to left door panel (part W) and right door panel (part X) using small round head screws (part #12) and phillips head screwdriver

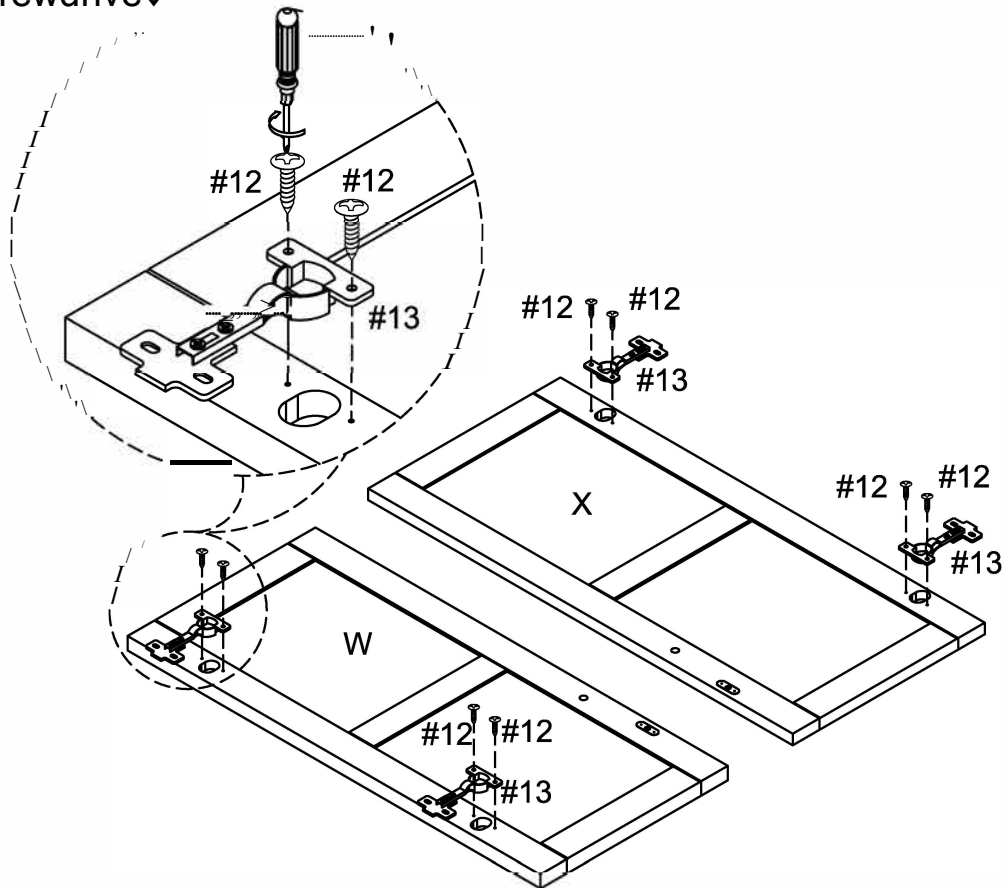

#12 x 8
#13. _x 4

Step 3. Attach magnets (part #11) to left partition panel (part D) and right partition panel (part E) using small round head screws (part #12) and phillips head screwdriver. Insert cam bolts (part #3) to top panel (part A), left partition panel (part D) and right partition panel (part E) using phillips head screwdriver.

NOTE: Do not overtighten cam bolts. Stop tightening once threads on cam bolt are no longer visible.

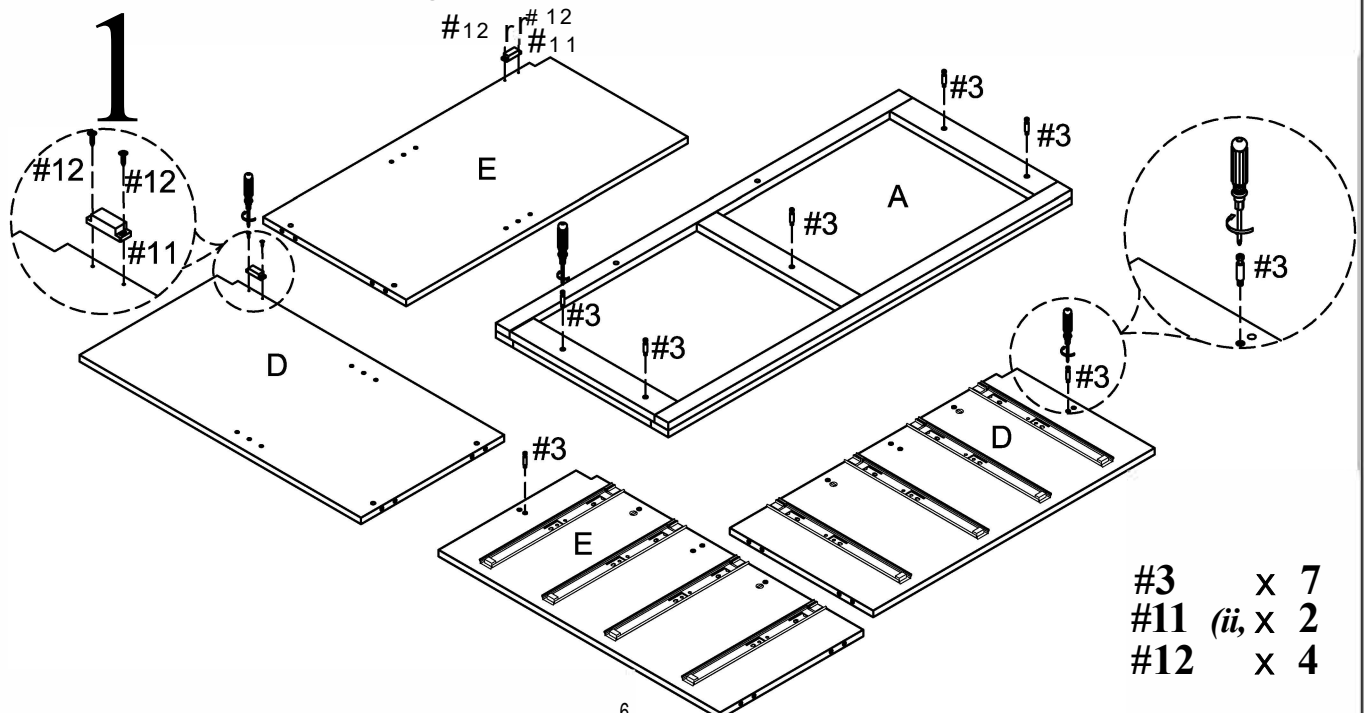

#3 x 7
#11 (ii) x 2
#12 x 4

Step 4. Attach top drawer left side panel (part O) and top drawer right side panel (part P) to top drawer back panel (part Q) using small wood dowels (part #2) and lock the hardware. Slide drawer bottom panel (part V) into grooves of assembled unit (parts O, P & Q). Attach top drawer front panel (part N) to assembled unit (parts O, P & V) using small wood dowels (part #2) and lock the hardware. Repeat for remaining drawers.

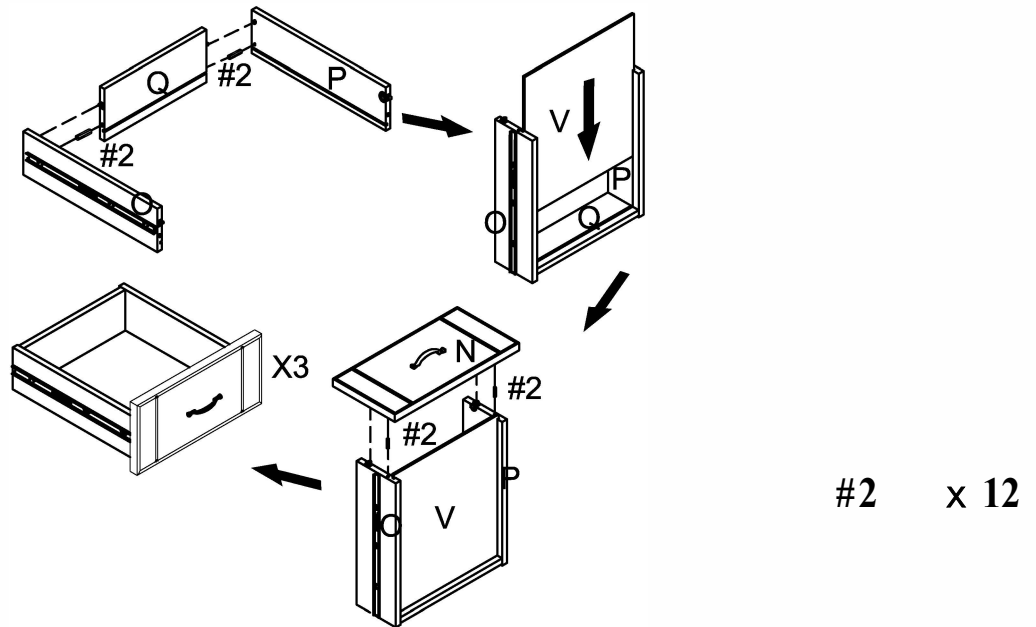

Step 5. Attach bottom drawer left side panel (part S) and bottom drawer right side panel (part T) to bottom drawer back panel (part U) and lock the hardware. Slide drawer bottom panel (part V) into grooves of assembled unit (parts S, T, & U). Attach bottom drawer front panel (part R) to assembled unit (parts S, T, & V) and lock the hardware.

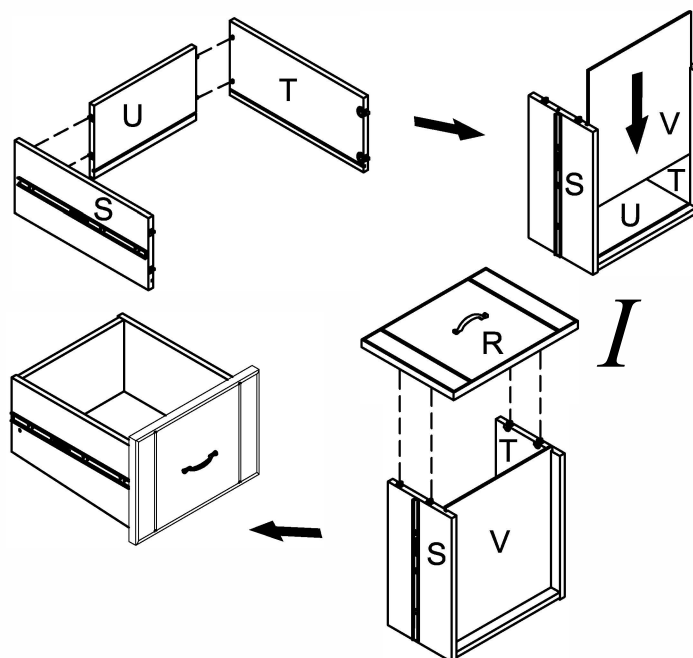

Step 6. Attach top rail (part G), front rails (part H) and front middle rail (part I) to left partition panel (part D) using large wood dowels (part #1), cam lock (part #4) and lock the hardware.

NOTE: Cam locks must rotate a full 180°. See pictured insert.

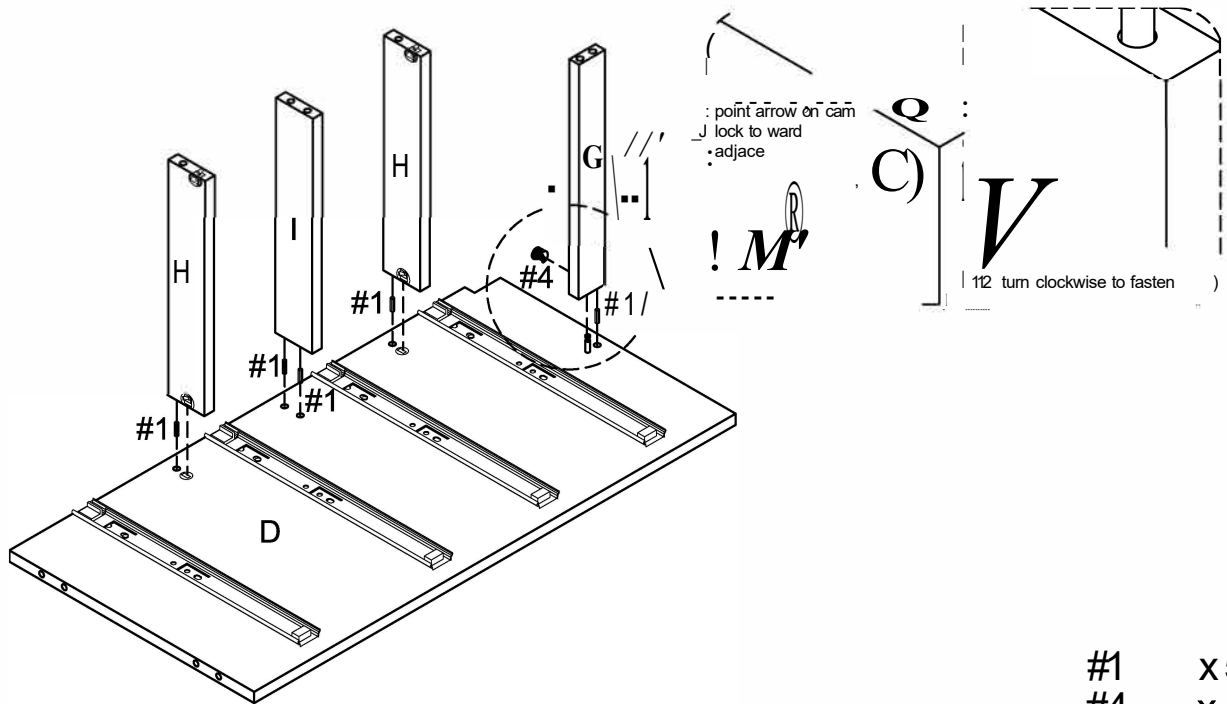

#1 x5
#4 x 1

Step 7. Attach top rail (part G), front rails (part H) and front middle rail (part I) to right partition panel (part E) using large wood dowels (part #1), cam lock (part #4) and lock the hardware.

NOTE: Cam locks must rotate a full 180°. See pictured insert.

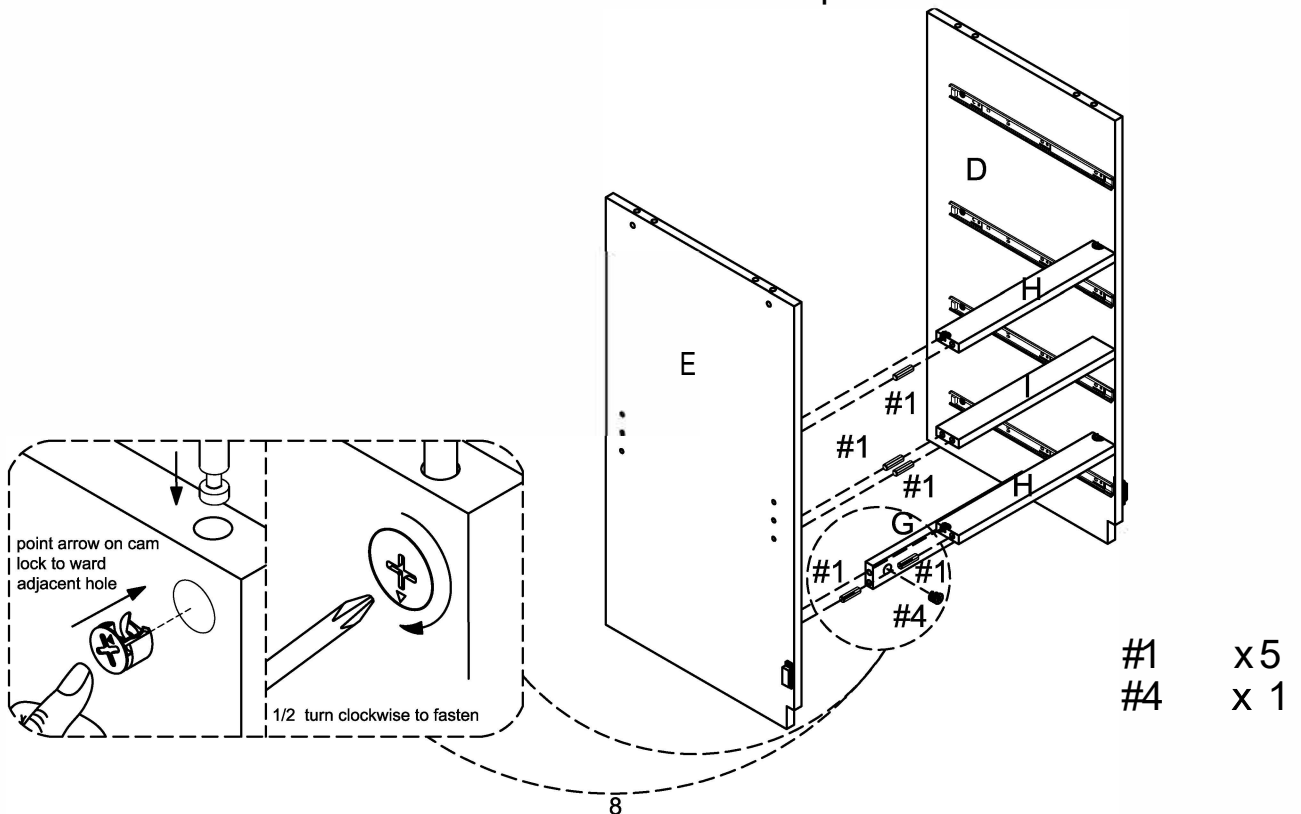

#1 x5
#4 x 1

Step 8. Attach bottom panel (part F) to left partition panel (part D) and right partition panel (part E) using large wood dowels (part #1), bolts (part #9), barrel nuts (part #8) and allen wrench (part #15).

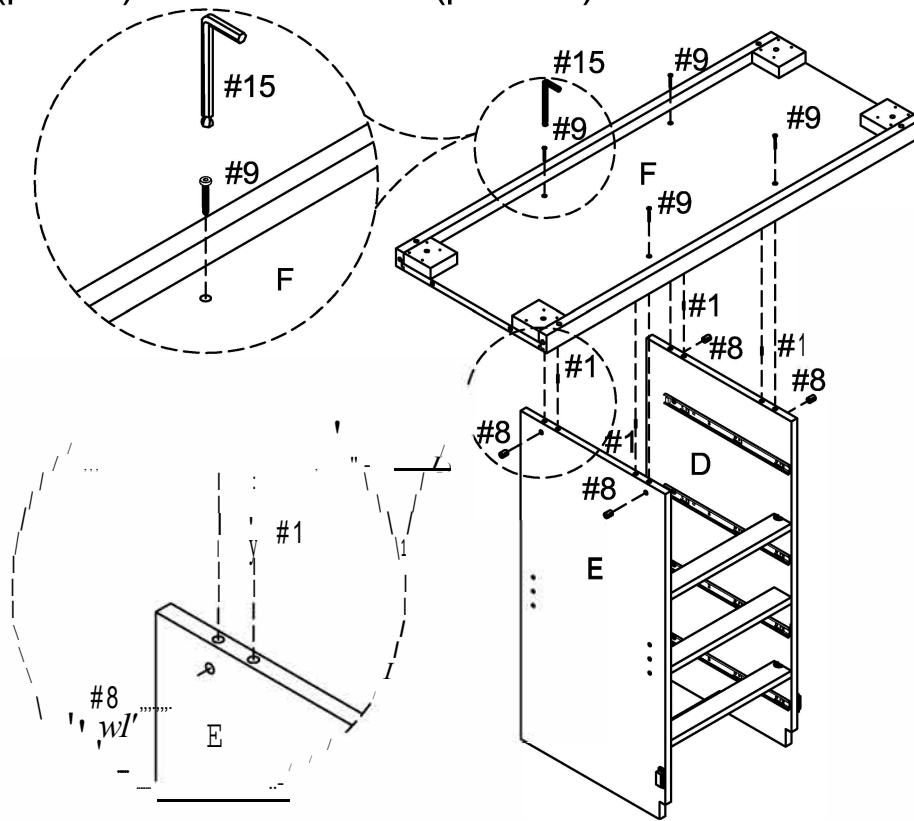

- #1 x4
- #8 x4
- #9, x4
- #15'>x 1

Step 9. Attach left side panel (part B) to bottom panel (part F) using large wood dowels (part #1), bolts (part #9) and allen wrench (part #15).

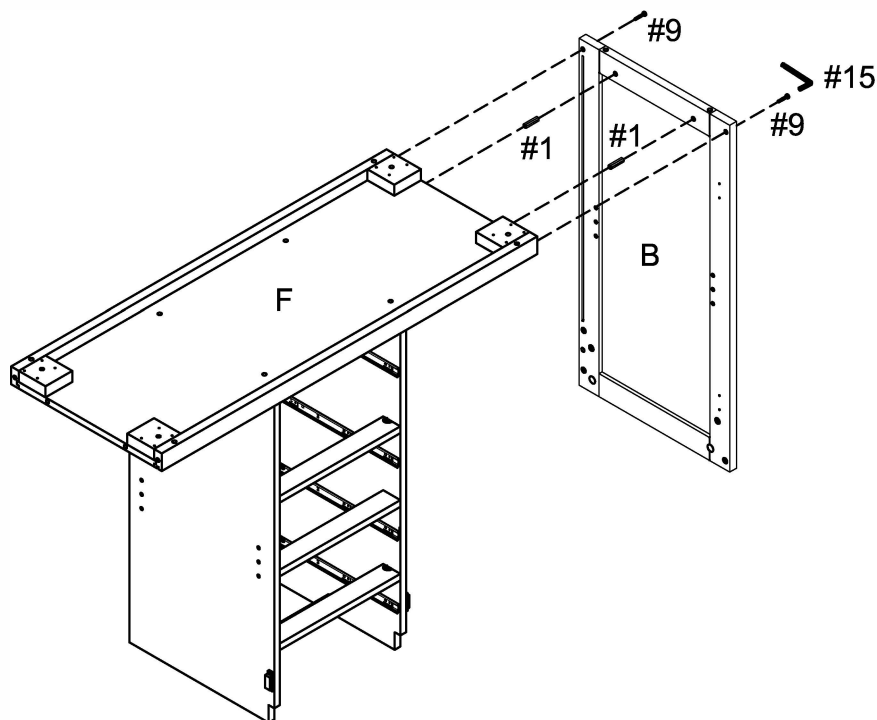

- #1 x2
- #9, x2
- #15'>x 1

Step 10. Attach locking casters (part ZG) and casters (part ZH) to bottom panel (part F) using large round head screws (part #14) and phillips head screwdriver.

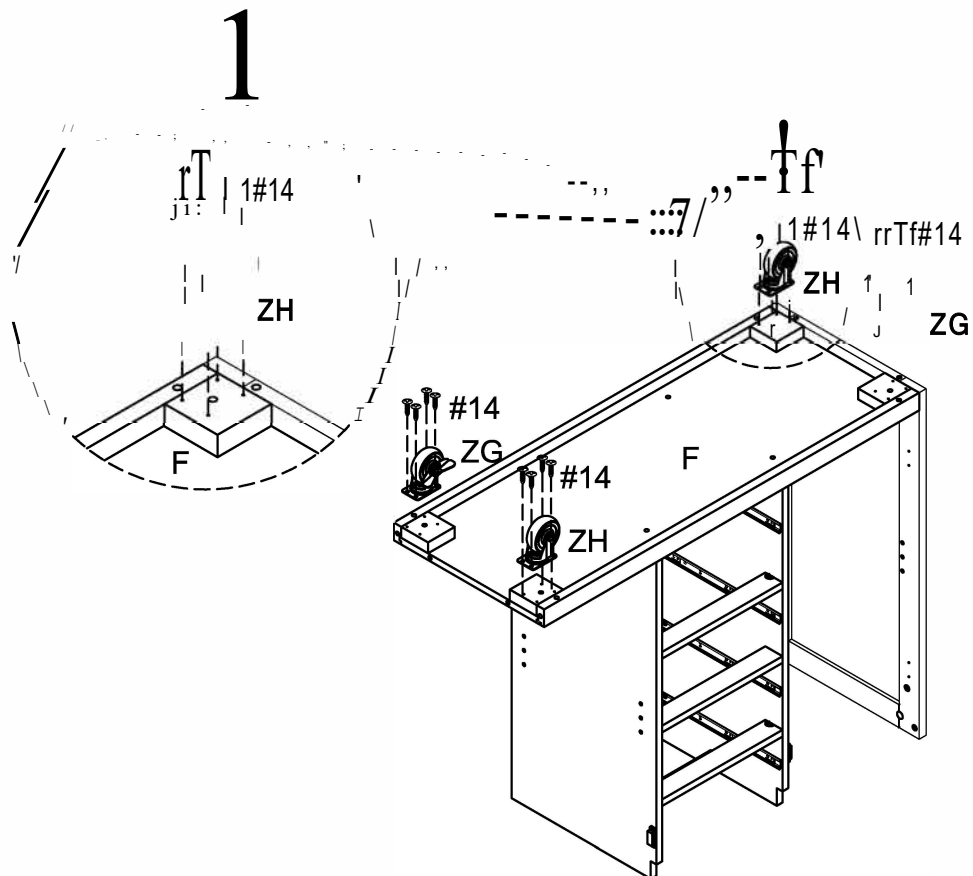

Step 11. Carefully turn unit upright. Attach back rails (part K) to bottom panel (part F) using large wood dowels (part #1). Slide back panels (part J) into grooves of left side panel (part B) and back rails (part K).

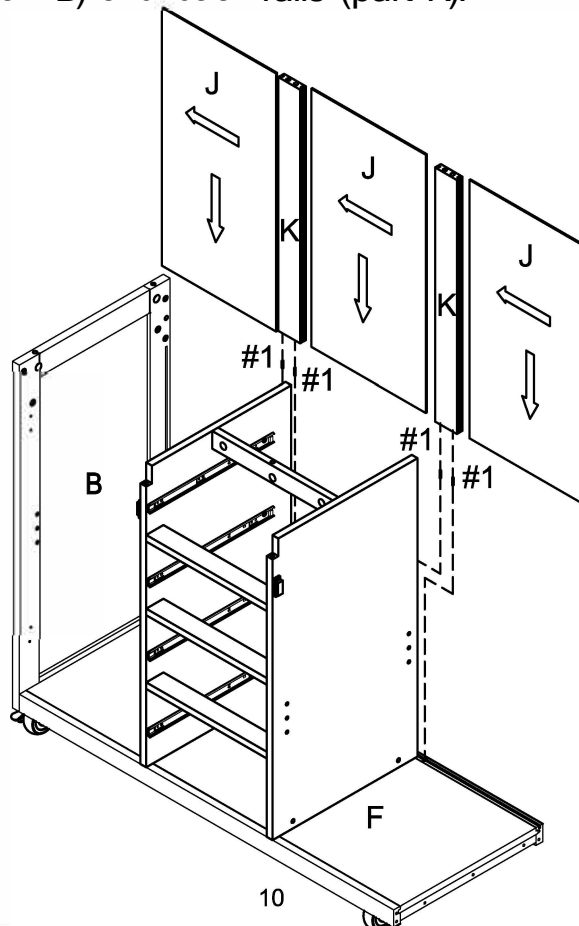

Step 12. Attach back top rail (part L) to back rails (part K), back panels (part J) and left side panel (part B) using large wood dowels (part #1) and lock the hardware.

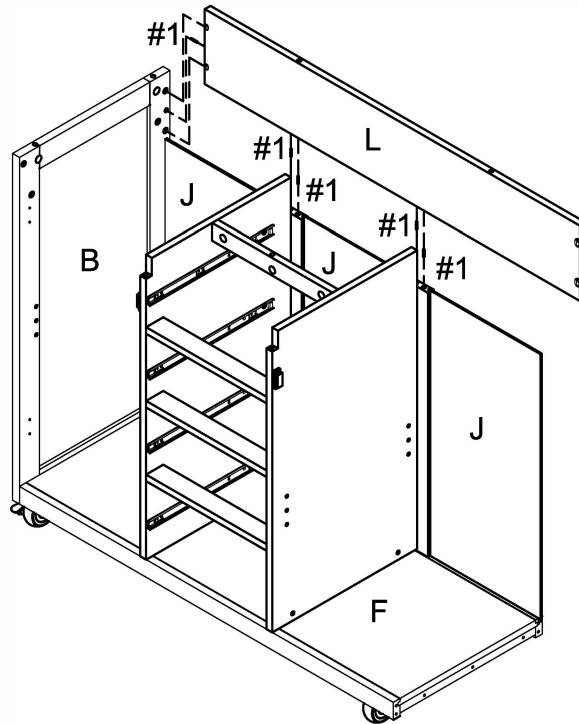

#1 x5

Step 13. Attach front top rail (part M) to left partition panel (part D), right partition panel (part E) and left side panel (part B) using large wood dowels (part #1) and lock the hardware. Attach right side panel (part C) to front top rail (part M), back top rail (part L), back panel (part J) and bottom panel (part F) using large wood dowels (part #1), bolts (part #9), allen wrench (part #15) and lock the hardware.

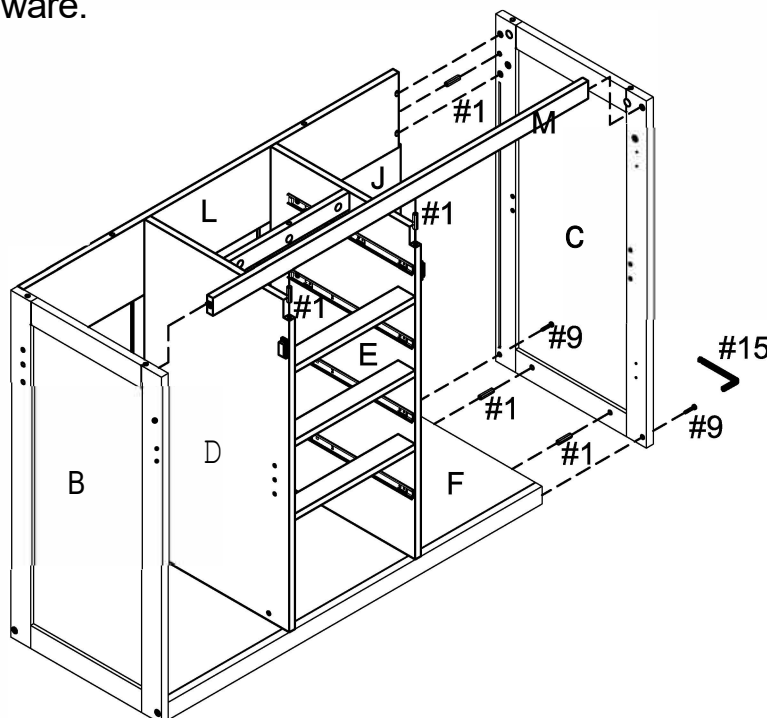

#1 x5
 #9, x2
 #15'>x 1

Step 14. Insert large support bar (part ZB) and small support bars (part ZC) into pre-drilled holes of towel bar right side panel (part Z). Attach towel bar support panel (part ZA) to towel bar right side panel (part Z) using large wood dowels (part #1) and lock the hardware. Attach towel bar left side panel (part Y) to towel bar support panel (part ZA), large support bar (part ZB) and small support bars (part ZC) using large wood dowels (part #1) and lock the hardware.

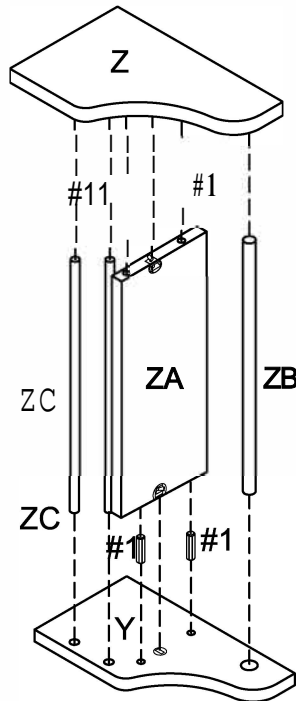

#1 x4

Step 15. Attach assembled unit (parts Y, Z, ZA, ZB & ZC) to left side panel (part B) using large wood dowels (part #1), bolts (part #9) and allen wrench (part #15). Attach small towel bar panels (part ZD) to right side panel (part C) using large wood dowels (part #1), bolts (part #9) and allen wrench (part #15). Insert small towel bar (part ZE) through the holes of small towel bar panels (part ZD).

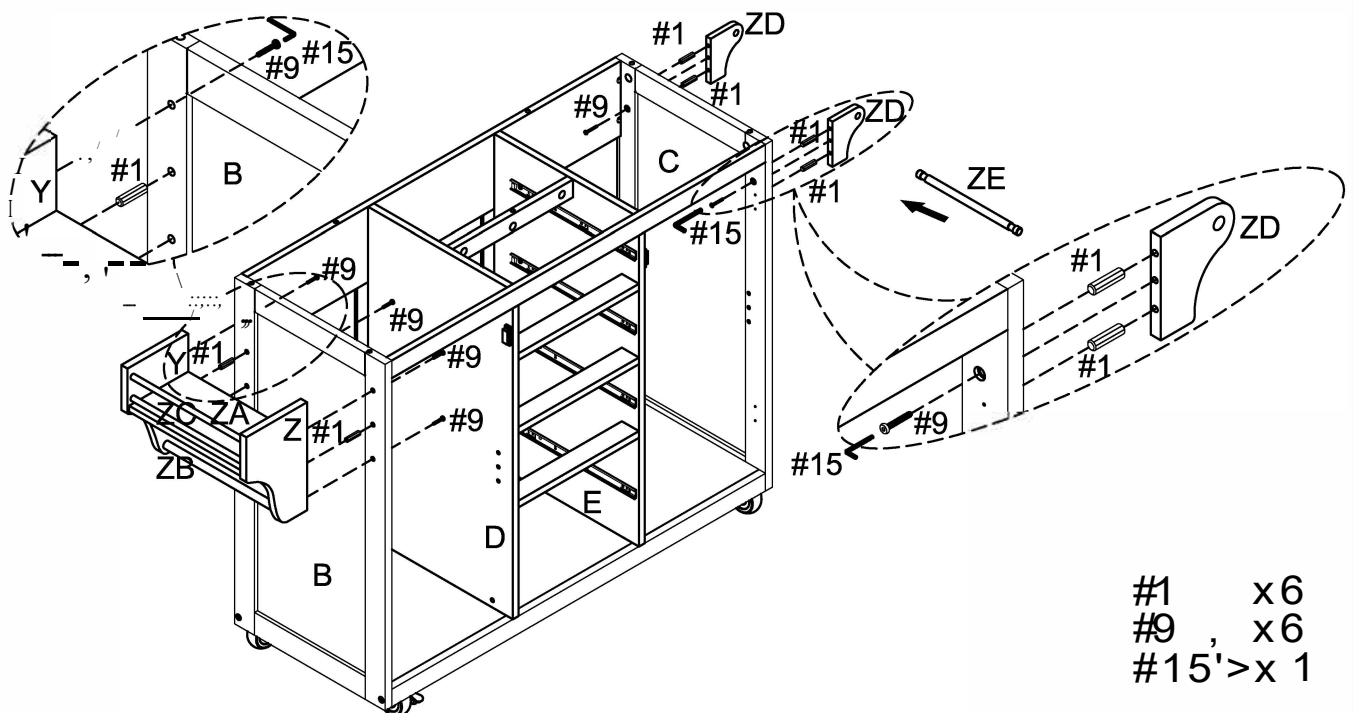

#1 x6
 #9 x6
 #15 > x1

Step 16. Attach top panel (part A) to assembled unit (parts B, C, G, L & M) using large wood dowels (part #1) and cam locks (part #4).

NOTE: Cam locks must rotate a full 180°. See pictured insert.

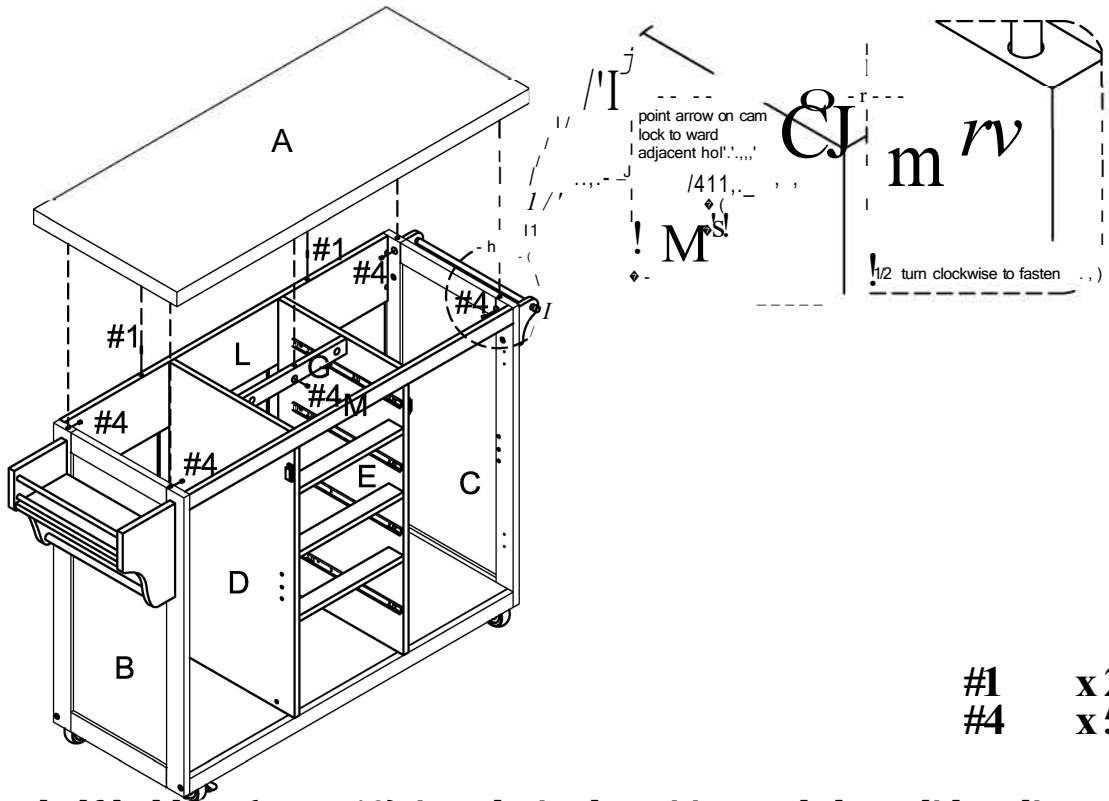

Step 17. Place shelf holders (part #10) into desired position and then slide adjustable shelves (part ZF) into place.

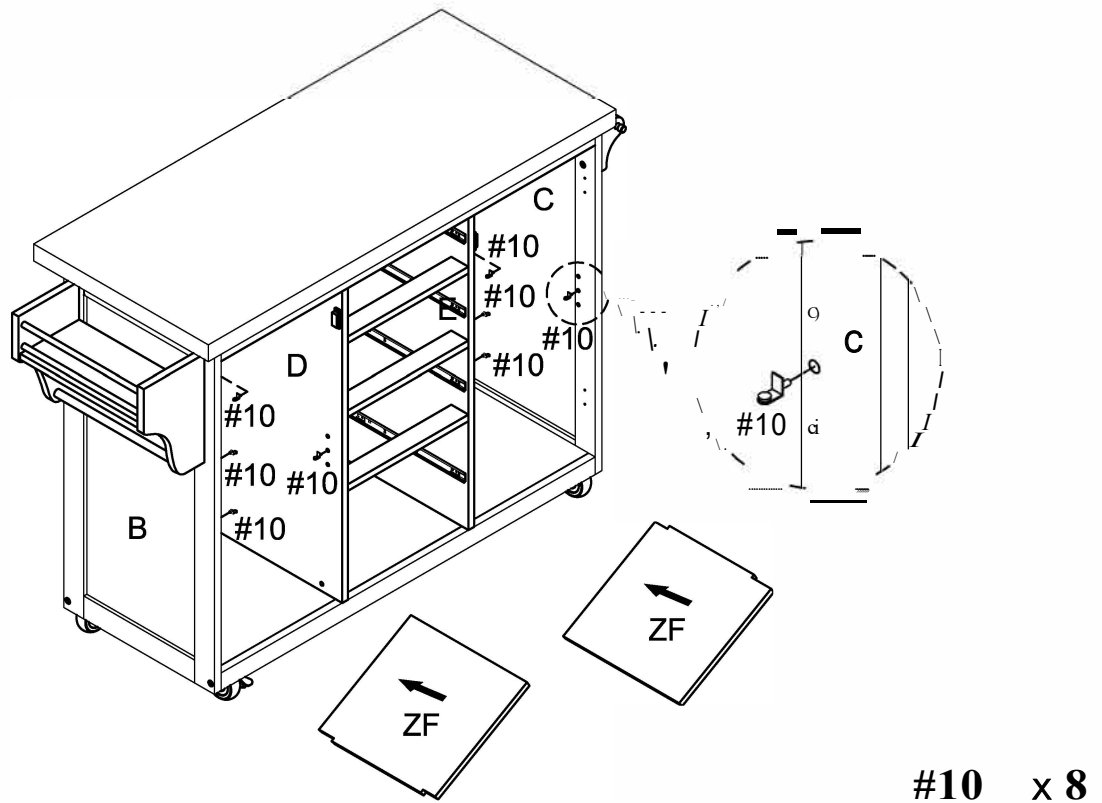

Step 18. Attach right door panel (part X) to right side panel (part C) using installed door hinges (part #16), small round head screws (part #12) and phillips head screwdriver. Attach left door panel (part W) to left side panel (part B) using installed door hinges (part #13), small round head screws (part #12) and phillips head screwdriver.

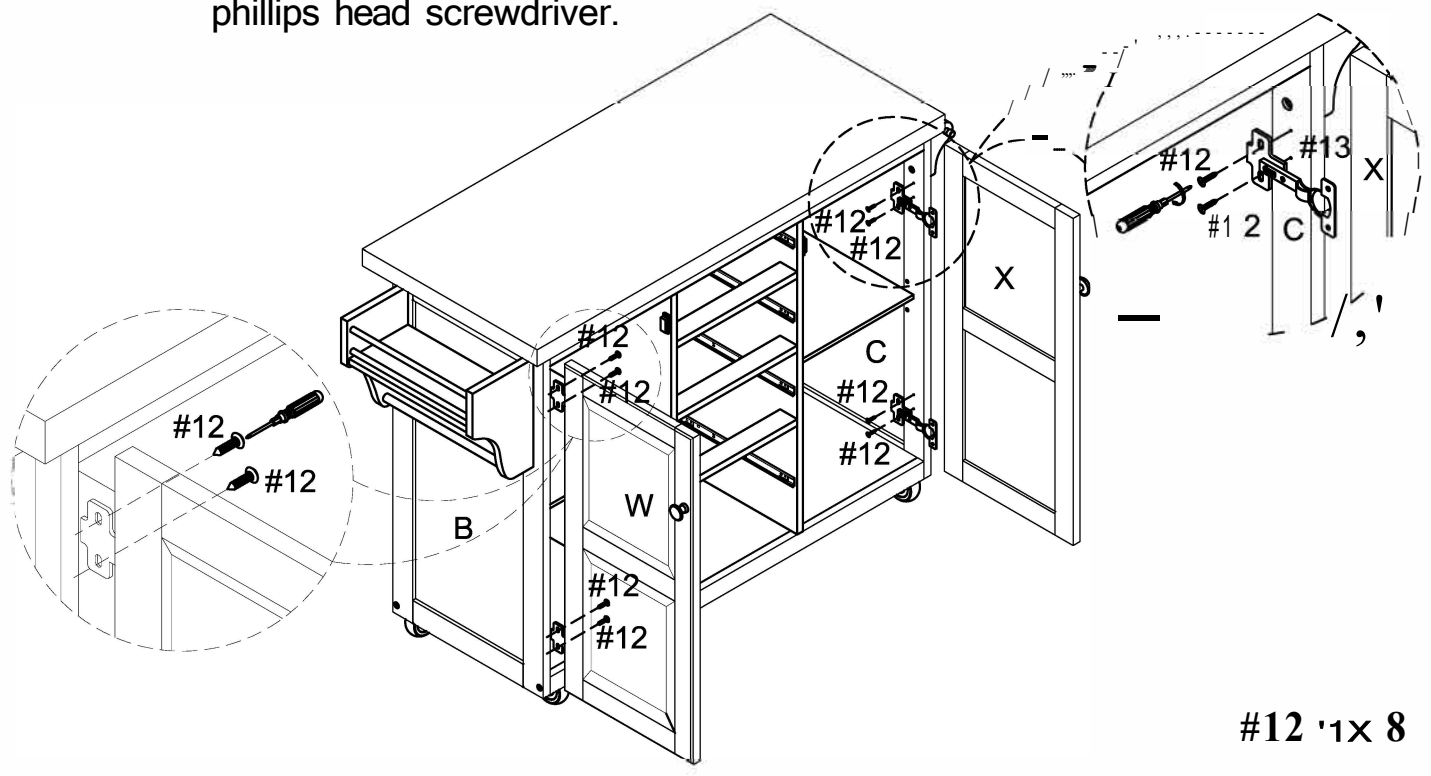

Step 19. Slide assembled drawers into place.

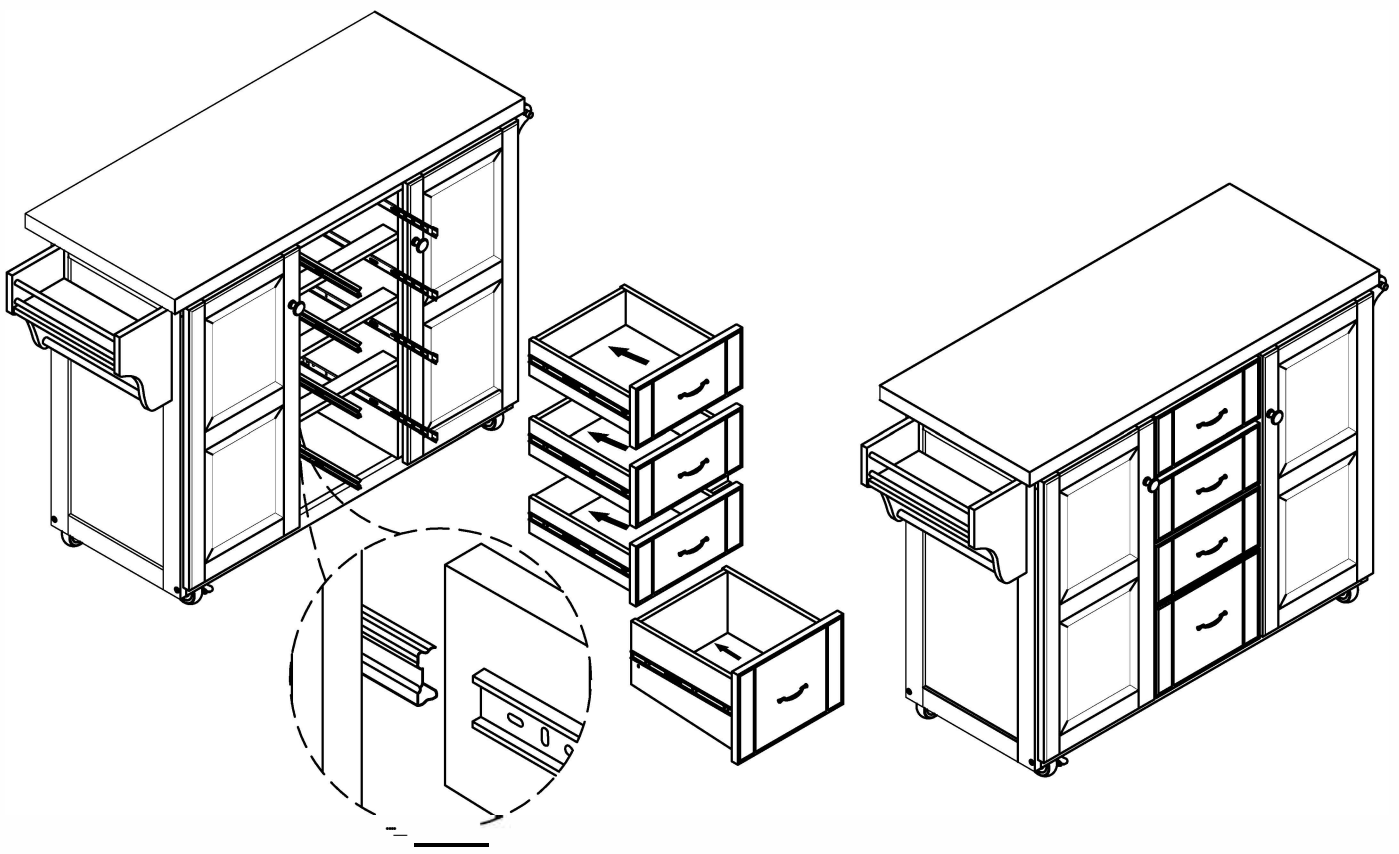

ADJUST YOUR DOORS TO MAKE THE GAPS MORE EVEN (OPTIONAL).

STEP 1

Open the door.

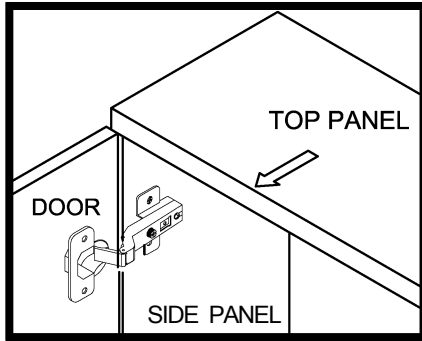

STEP 2

Adjust the gap between door panel and side panel

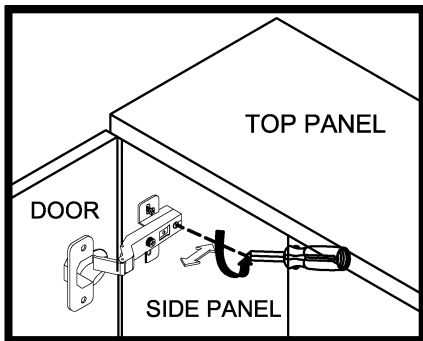

Loosen the screw indicated a little, adjust the hinge to right position (see step 2a & 2b), then tighten the screw.

STEP 2a MOVE DOOR IN

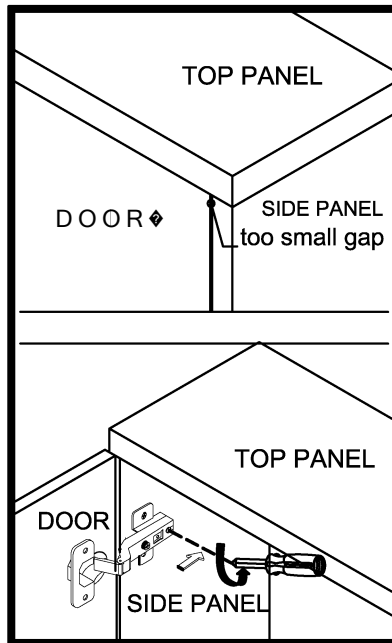

Push the hinge back a little.

STEP 2b MOVE DOOR OUT

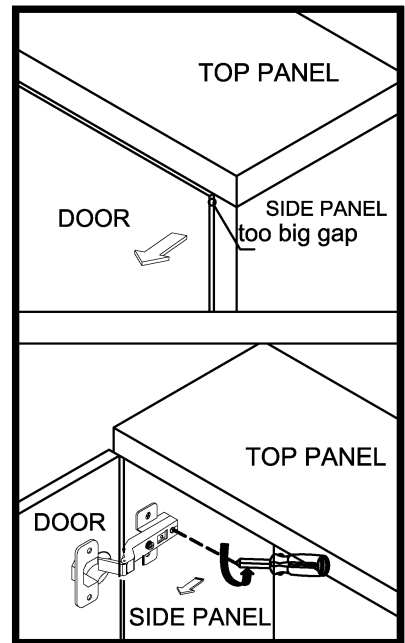

Pull the hinge forward a little.

STEP 3

To adjust the gap between two door

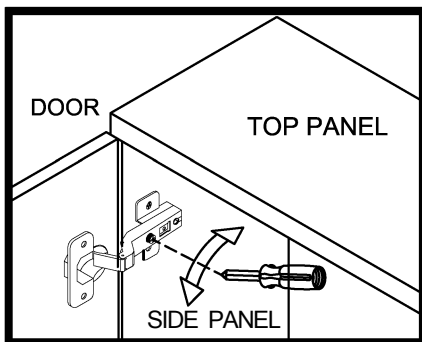

Loosen or tighten the screw indicated a little to adjust the gap between doors panels (see step 3a & step 3b)

STEP 3a MOVE DOOR RIGHT

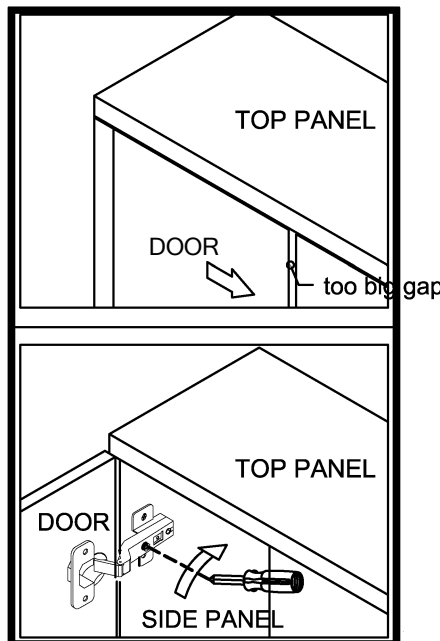

Turn the screw clockwise a little as shown to make the gap small.

STEP 3b MOVE DOOR LEFT

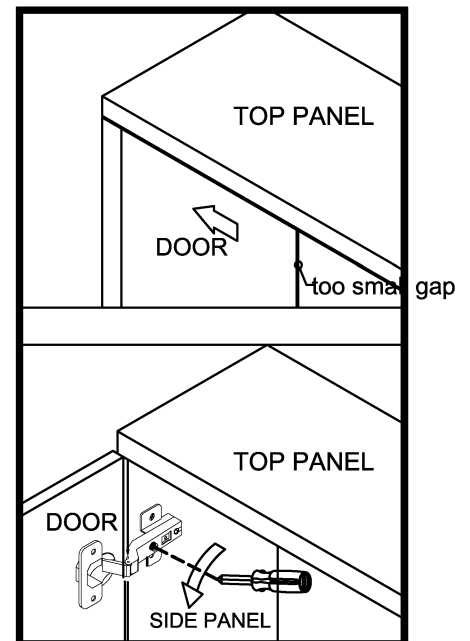

Turn the screw counterclockwise a little as shown to make the gap big.