

# ASSEMBLY INSTRUCTIONS

## Customer service



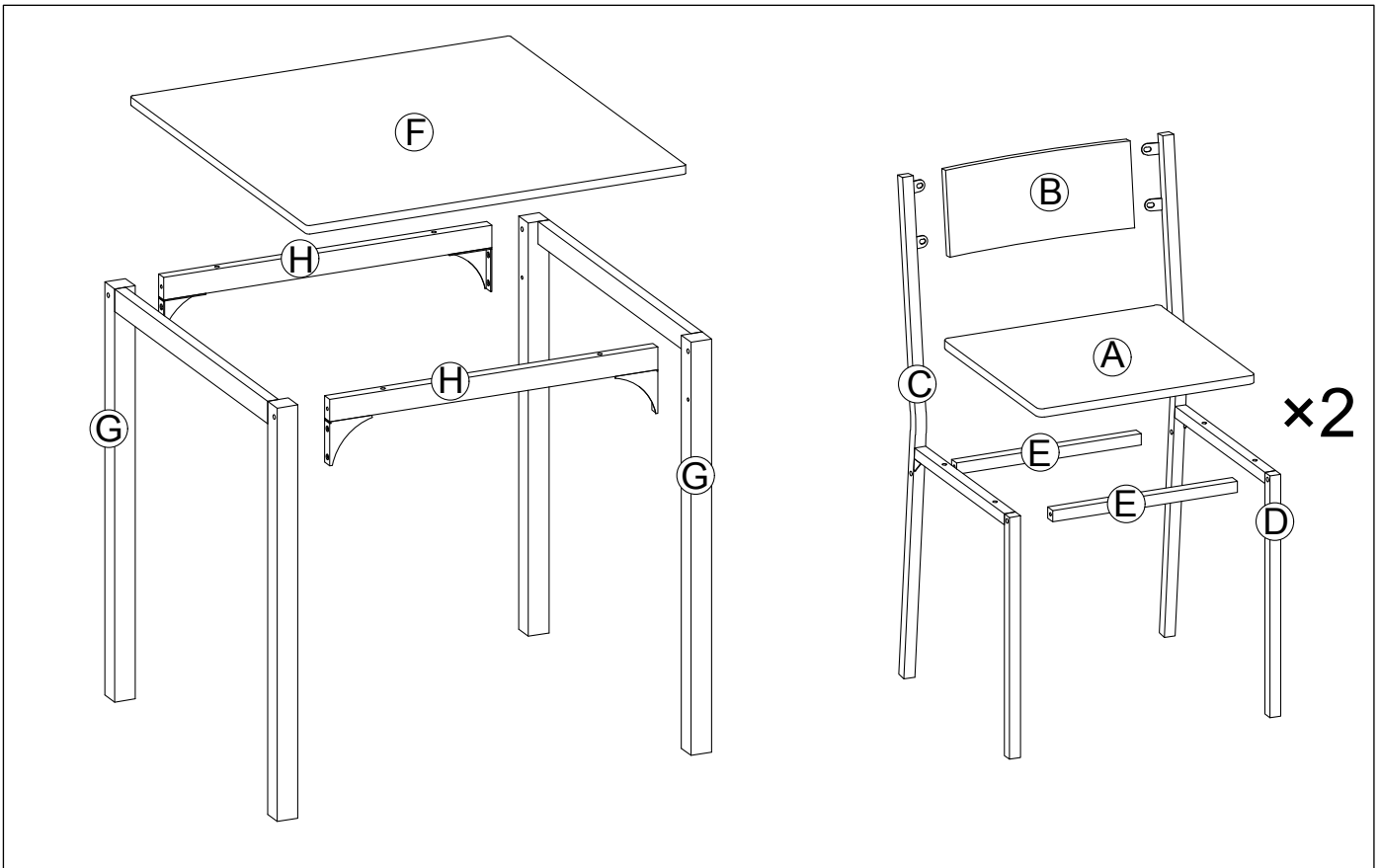
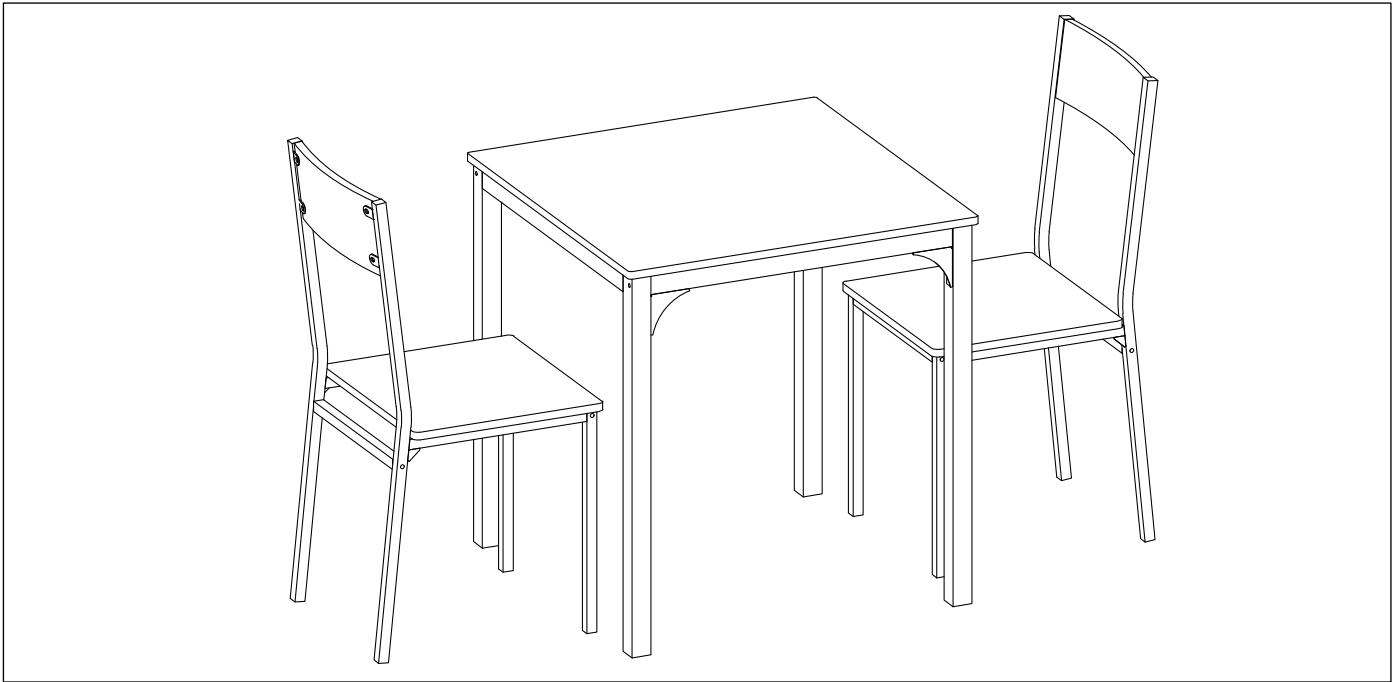

Thank you for your purchase! Please read the instructions fully before assembly. These instructions include important information which could ensure correct assembly. We have been working on providing high quality products for you. However, in the rare instance that your product is defective, missing parts or there are some issues, please don't hesitate to contact our customer service to submit parts requirements, assembly suggestion, or warranty claims, and we will give the best solution as soon as possible. If necessary, we need you to provide some more clear pictures of the issue.

## TIPS



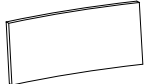
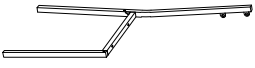
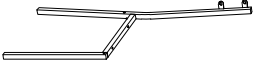

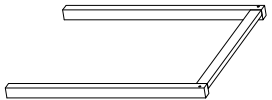
1. ! ! Please notice the use between screw M6×50mm and the screw M6×55mm. If you do not strictly follow the instructions to use the 2 types of screws, the screws may penetrate the board surface.
2. when start to the assembly, insert the screws into the holes, not 100% tighten, 70 ~ 80% is OK. Finally tighten all the screws. If some issues happened that some screws can not target to holes or some parts cannot be installed, please adjust the tightness of the screws.



### part list

	
A×2PCS	B×2PCS
	
C×2PCS	D×2PCS
	
E×4PCS	F×1PC
	
G×2PCS	H×2PCS

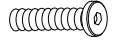
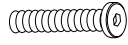
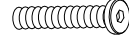
### hardware list

	
M6×12mm	M6×30mm
①×12PCS	②×8PCS
	
M6×40mm	M6×50mm
③×8PCS	④×4PCS
	
M6×55mm	M4
⑤×4PCS	⑥×1PC

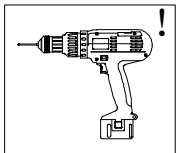

PLEASE BE CAREFUL DO NOT DAMAGE THE HOLE POSITION WHEN YOU USE POWER TOOLS !

### Step 1

  
M6×40mm  
③×8PCS

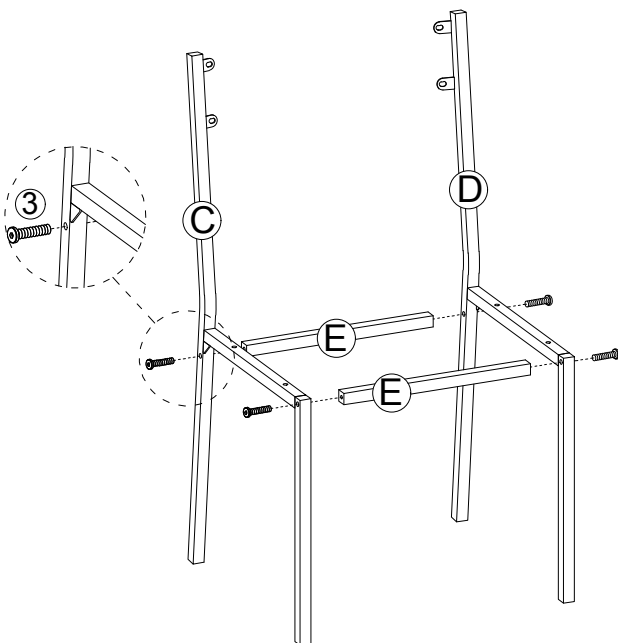

×2

### Step 2

  
M6×30mm  
②×8PCS

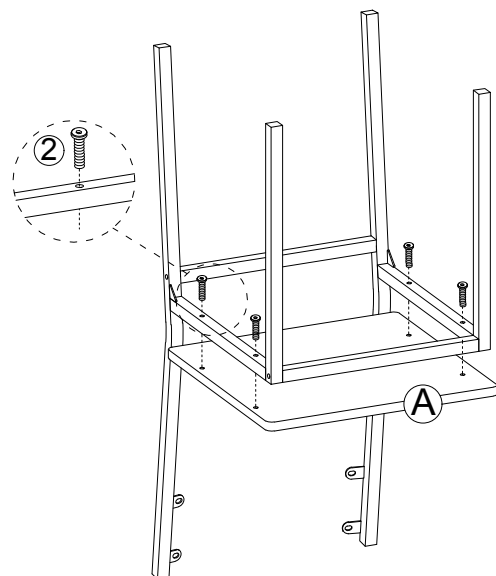

×2

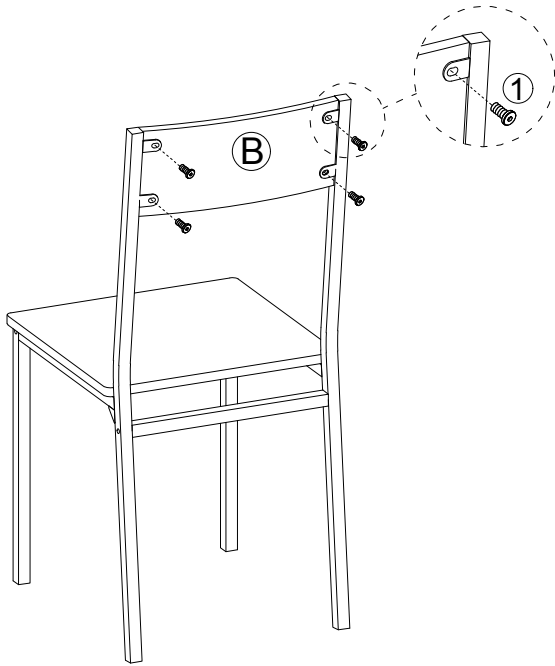

### Step 3

  
M6×12mm  
①×8PCS



×2

### Step 4

 M6×12mm ①×4PCS  
 M6×55mm ⑤×4PCS

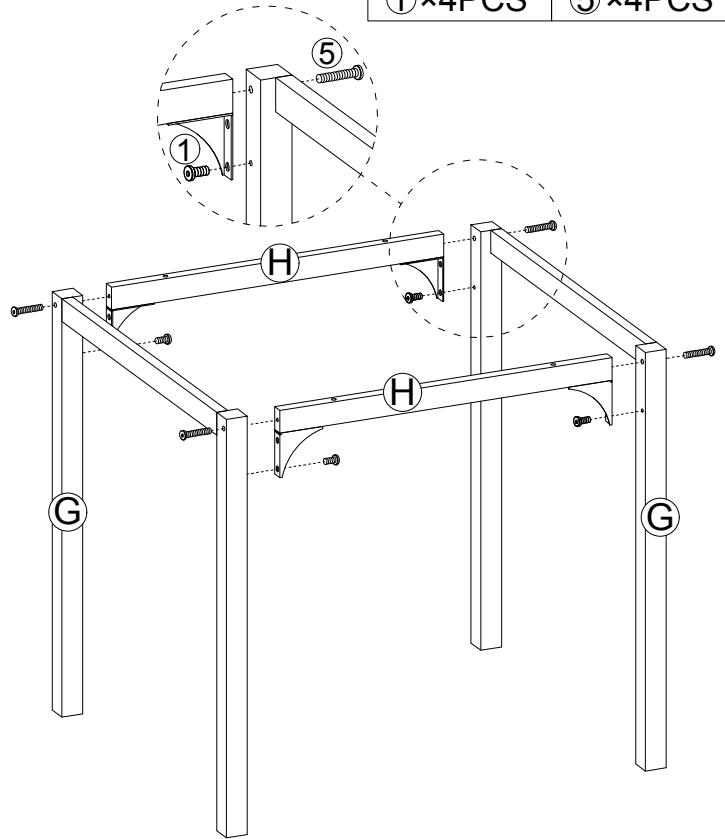

### Step 5

  
M6×50mm  
④×4PCS

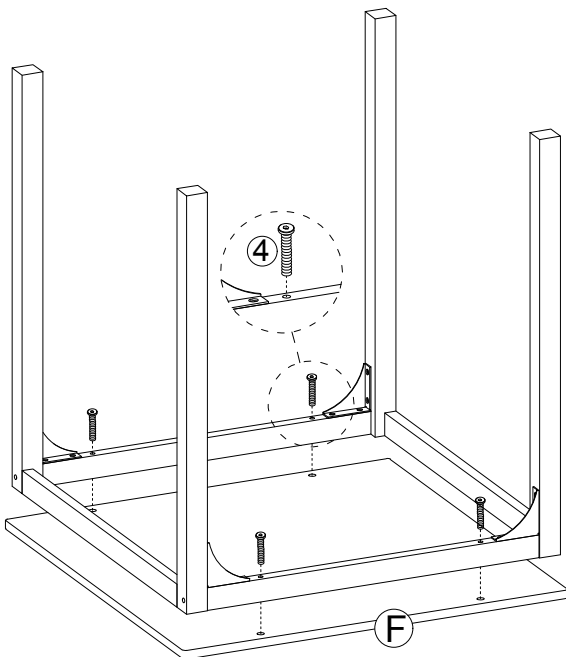

### Step 6

