

### InstallationDiagram

NO	1
NAME	Coat Rack

Note:(installed) in the parts list and hardware list It means it has been installed In the finished product and is not included In the hardware package!!

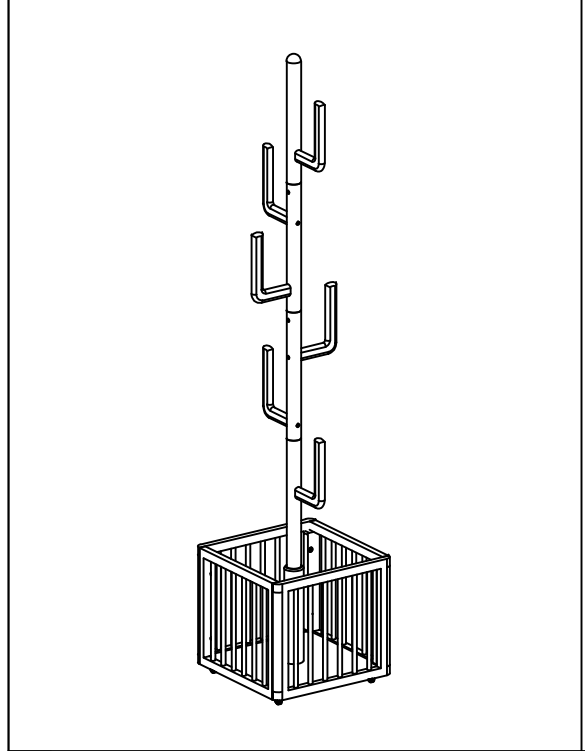

### Parts List

NO.	NAME	icon	Specification	amo unt
1	Basket side frame		345*395*20mm	2
2	Basket front and backframes		345*355*40mm	2
3	Basket bottom plate		355*355*17mm	1
4	Thickened Lower Lathe-Turned		280* $\phi$ 55mm	1
5	Upper Middle Post		380* $\phi$ 40mm	1
6	Upper Middle Post1		420* $\phi$ 40mm	1
7	Upper Middle Post2		420* $\phi$ 40mm	1
8	TopLathe-TurnedSection		420* $\phi$ 40mm	1
9	Long Hook Arm		210*125*18mm	6

### Hardware Accessories List

NO.	NAME	icon	Specification	amo unt
A	Hexagon socket screw		M8*35mm	3
B	Flat Washer		M8*19mm	3
C	Hex Key with Phillips Tip		M5*65mm	1
D	Thre aded Stem C aster		M6x10mm Caster, 25mm Wheel Height 38mm wi th Brake	2
E	Thre aded Stem C aster		M6x10mm casters, 25mm wheel, height 38mm, wi thout brake	2
F	Open-End Wrench		10mm Wrench (Open-End)	1
G	Hex Socket Connector Bolt		M7*30mm	4
H	Allen Wrench		M4*100mm	1
I	Flat Head Hex Screw		M6*30mm	9
J	Assem y Rod		L=40MM	9
K	Lo cking C ollar		$\phi$ 15MM	9
L	Dowel Pin		$\phi$ 8*30MM	13
M	Huanmei Brand Adhesive Tape		$\phi$ 20MM	9
N	Button Head Hex Socket Cap Screw		M6*50mm	7

Specification Name: Coat Rack

step1

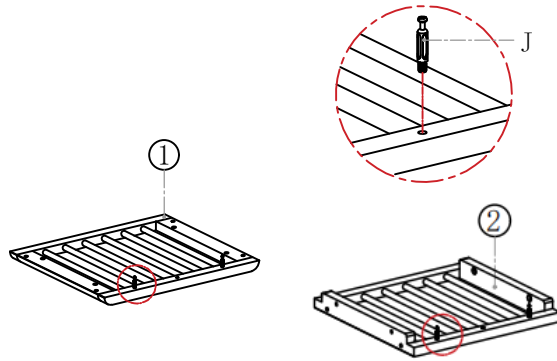

Notes: After unpacking, please check all parts against the instruction manual to ensure the quantities match before starting assembly.  
 ▶As shown, attach Part 1/2 using hardware J.

step2

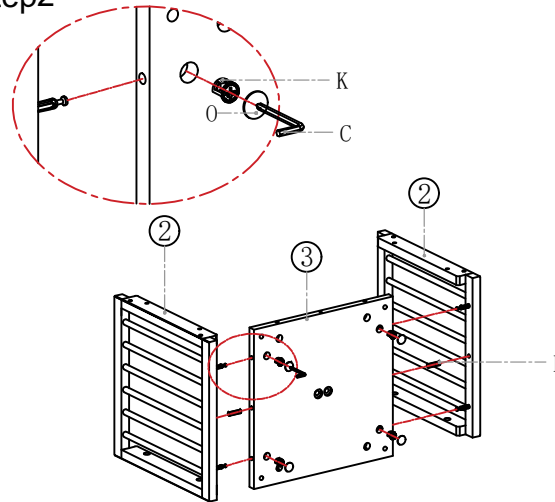

▶Attach Parts 2 and 3 with hardware K and L as shown. Cover K with hardware O.

step3

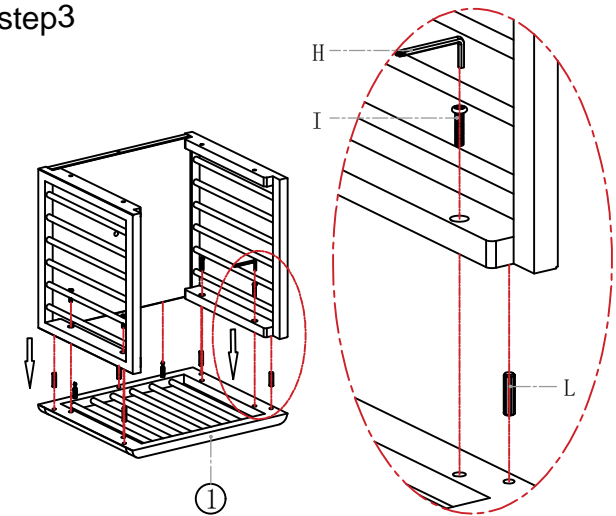

▶As shown, attach Part 1 to the assembly from Step 2 using hardware I and L.

step4

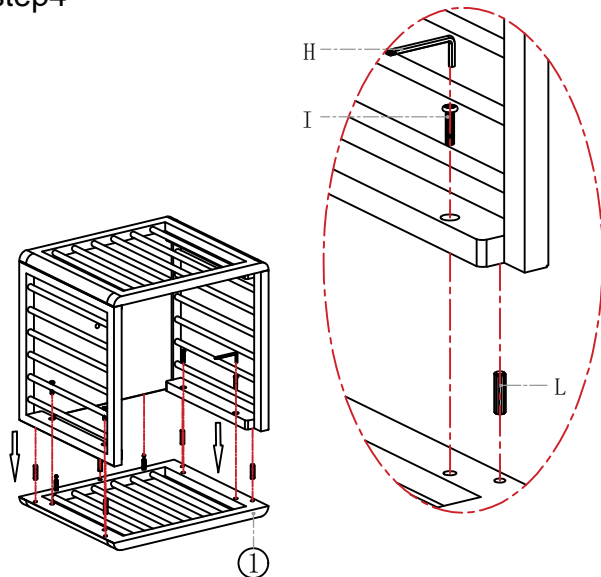

▶As shown, attach Part 1 to the assembly from Step 3 using hardware I and L.

step5

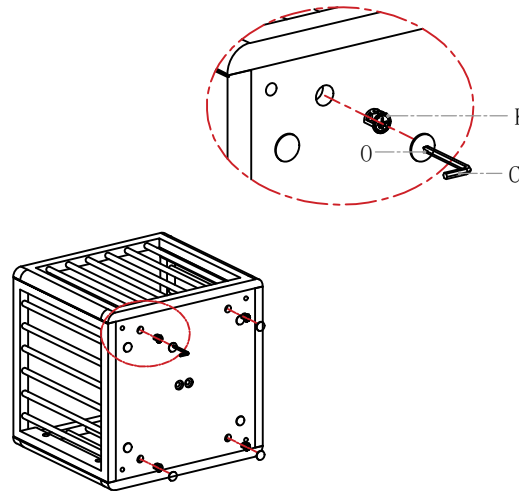

▶As shown, assemble using hardware K, then cover hardware K with hardware O.

step6

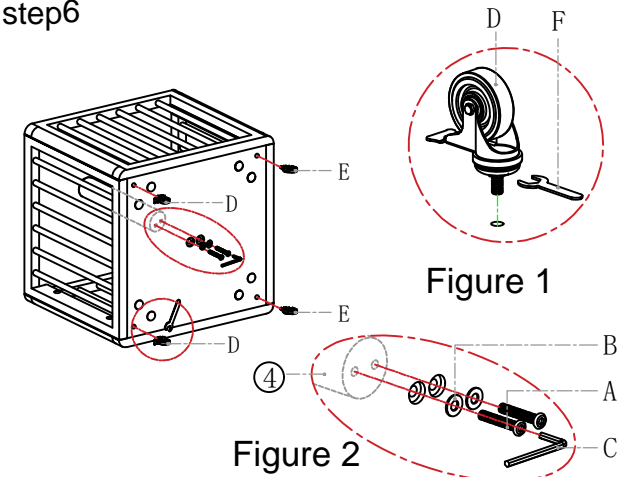

▶Attach hardware D and E to the bottom holes of the assembly from Step 5 using hardware F.  
 ▶Align Part 4 with the two center holes on the bottom. Use hardware C to fasten hardware A and B.

Specification Name: Coat Rack

step7

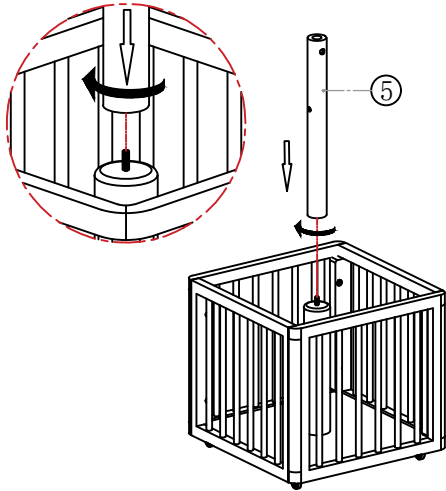

►As shown, attach Part 5 to the assembly from Step 6 and tighten

step8

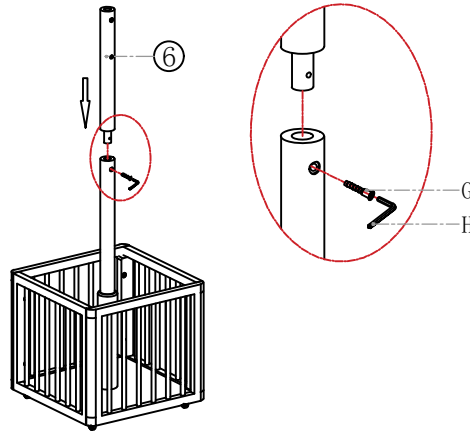

► As shown, install hardware G on Part 6 and the assembly from Step 7 using hardware H.

step9

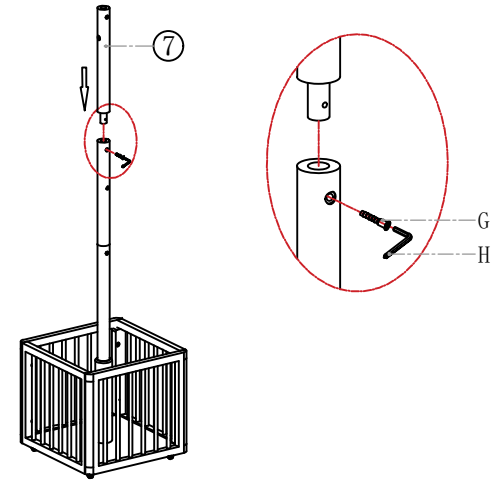

►As shown, install hardware G on Part 7 and the assembly from Step 8 using hardware H.

step10

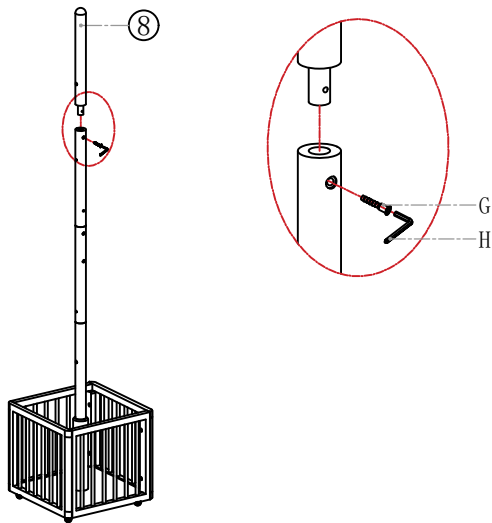

►Attach hardware G to Part 8 and the Step 9 assembly using hardware H, as shown.

step11

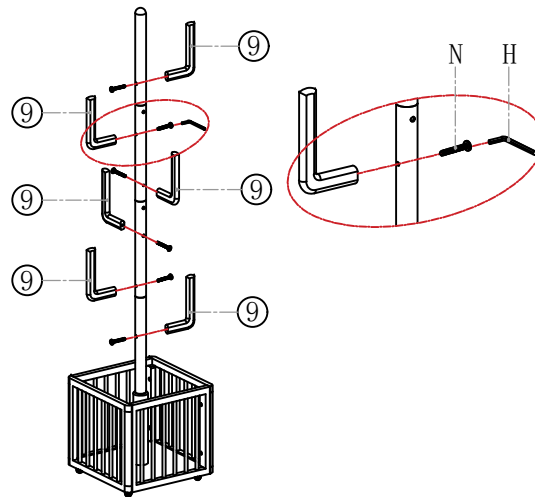

►As shown, install Parts 9 and the assembly from Step 10 using hardware N and H.

step12

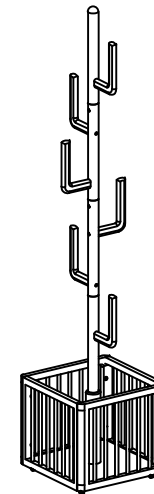

►As shown, assembly complete.