

ASSEMBLY INSTRUCTIONS



ASSEMBLY INSTRUCTIONS

ASSEMBLY TIPS :

1. Remove hardware from box and sort by size.
2. Please check to see that all hardware and parts are present prior to start of assembly.
3. Please follow attached instructions in the same sequence as numbered to assure fast & easy assembly.



WARNING !

1. Don't attempt to repair or modify parts that are broken or defective. Please contact the store immediately.
2. This product is for home use only and not intended for commercial establishments.









ASSEMBLY TIME

35 MINUTES

PARTS IDENTIFICATION





B1 (BOX 1)

A	HEADBOARD PANEL		1PC
B	HEADBOARD TOP DECORATION		1PC
C	HEADBOARD SUPPORT		2PCS
D	LEFT HEADBOARD LEG		1PC
E	RIGHT HEADBOARD LEG		1PC
F	EAR PANEL SUPPORT		2PCS
G	HEADBOARD SUPPORT PANEL		1 PC

B2 (BOX 2)

H	FOOTBOARD PANEL		1PC
---	-----------------	--	-----

B3 (BOX 3)

I	BED SLAT		5PCS
J	BED SLAT SUPPORT		10PCS
K	LEFT BED RAIL		1PC
L	RIGHT BED RAIL		1PC
M	FOOTBOARD LEG		2PCS

NOTE:

Phillips head screw driver is required in the assembly process; however, manufacturer does not provide this item.

ASSEMBLY INSTRUCTIONS

ASSEMBLY TIPS :

1. Remove hardware from box and sort by size.
2. Please check to see that all hardware and parts are present prior to start of assembly.
3. Please follow attached instructions in the same sequence as numbered to assure fast & easy assembly.















WARNING !

1. Don't attempt to repair or modify parts that are broken or defective. Please contact the store immediately.
2. This product is for home use only and not intended for commercial establishments.

HARDWARE IDENTIFICATION

Z-B3 (BOX 3)

1	ALLEN WRENCH (Φ6 - BLK)		1PC
2	SHORT BOLT (Φ6 X 30mm - RBW)		4PCS
3	MEDIUM BOLT (Φ6 X 45mm - RBW)		20PCS
4	LONG BOLT (Φ6 X 60mm - RBW)		6PCS
5	SHORT FLAT HEAD SCREW (Φ4 X 16mm - RBW)		4PCS
6	MEDIUM FLAT HEAD SCREW (Φ4 X 32mm - RBW)		10PCS
7	LONG FLAT HEAD SCREW (Φ4 X 45mm - RBW)		4PCS
8	LOCK WASHER (Φ6 - RBW)		20PCS
9	SMALL FLAT WASHER (Φ7 X 19mm X 2.0 - RBW)		20PCS
10	BIG FLAT WASHER (3/8 x 25 x 1.0 - RBW)		14PCS
11	LEVELER (M6 x 23mm - RBW)		10PCS
12	WOOL DOWEL (M8 X 45MM)		4PCS

NOTE:

Phillips head screw driver is required in the assembly process; however, manufacturer does not provide this item.

ASSEMBLY INSTRUCTIONS

STEP 1

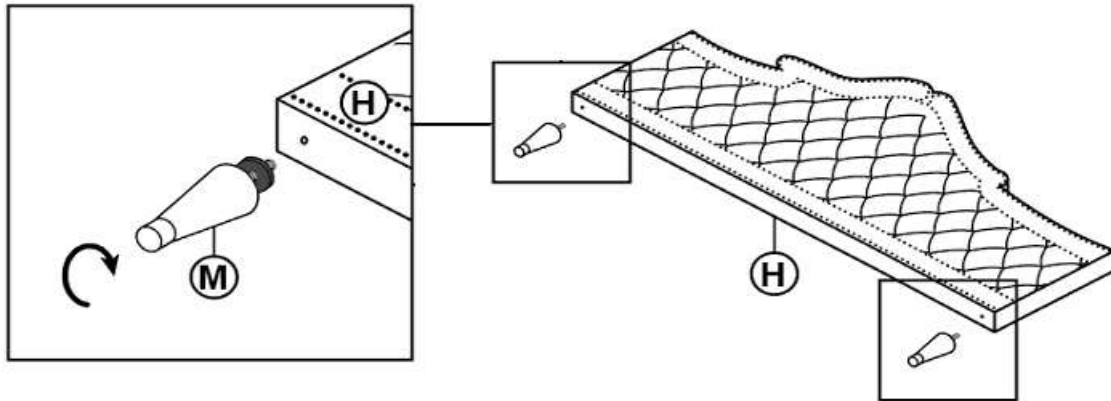

STEP 2

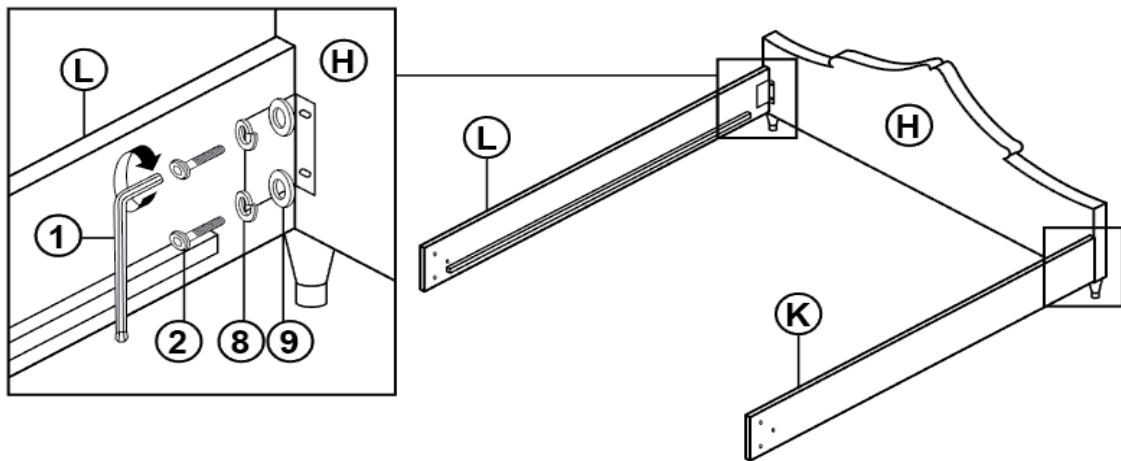

STEP 3

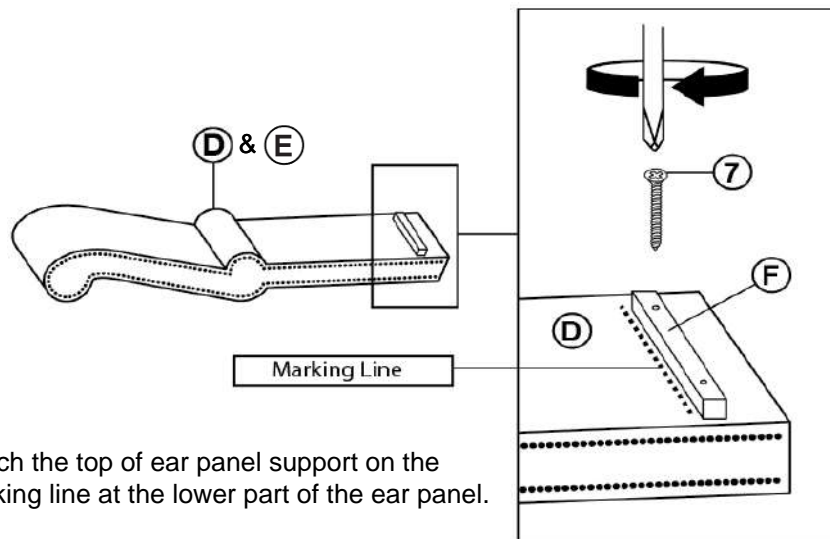

*Attach the top of ear panel support on the marking line at the lower part of the ear panel.

ASSEMBLY INSTRUCTIONS

STEP 4

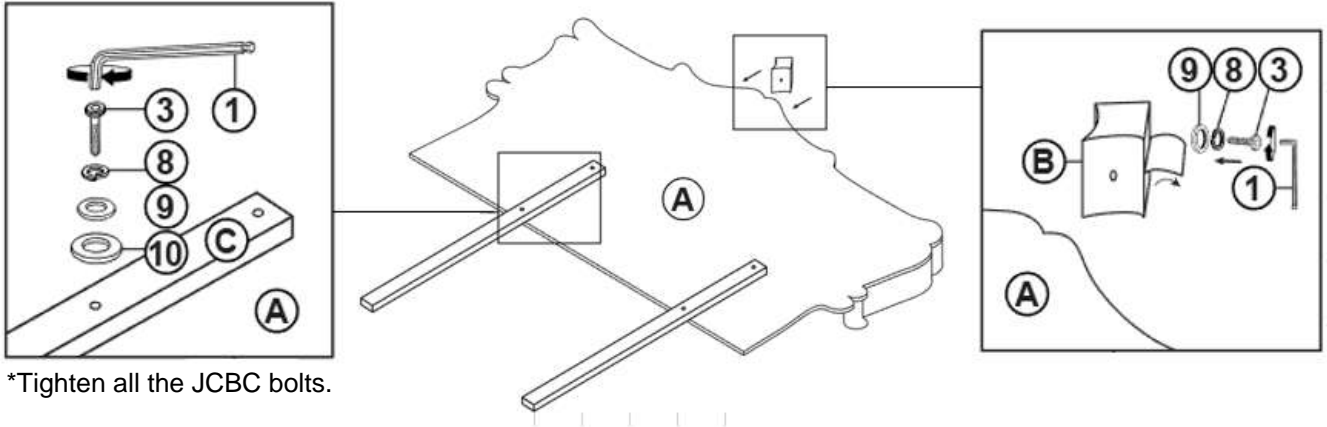

STEP 5

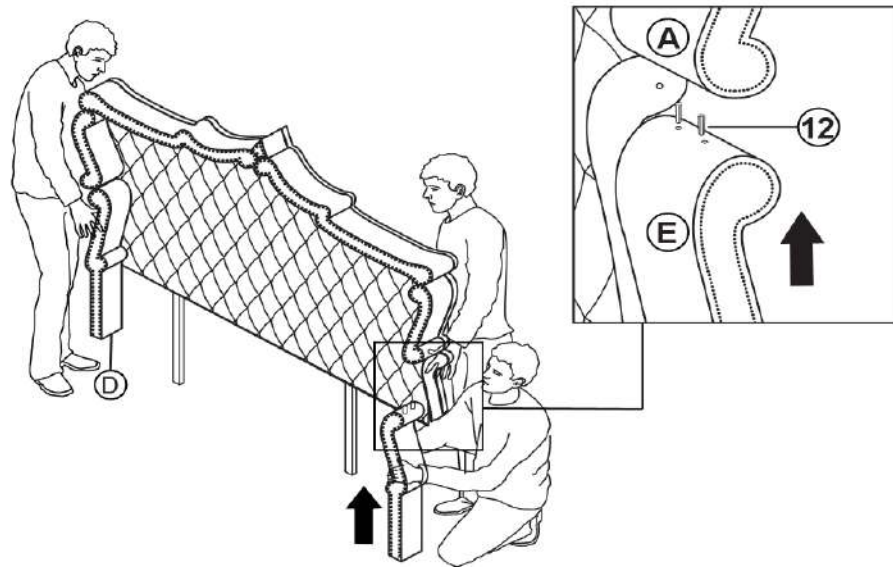

STEP 6

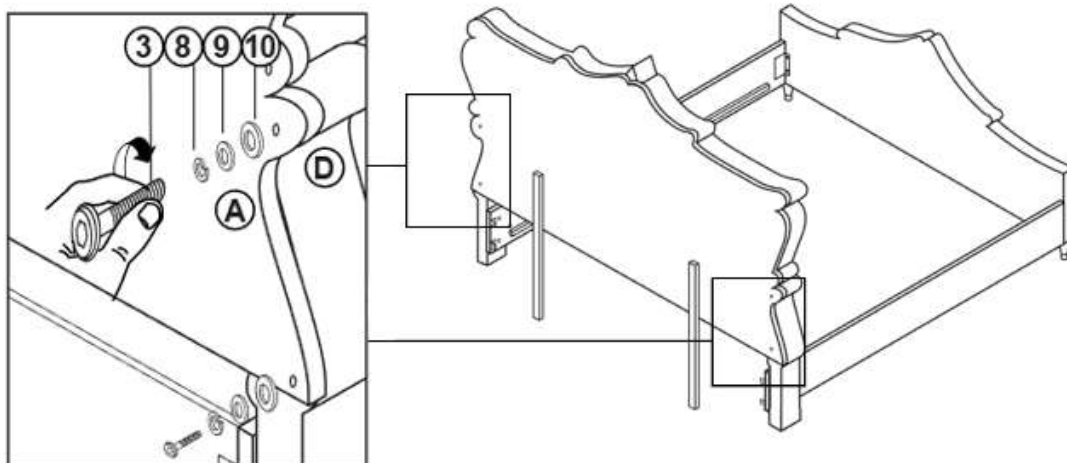

*Hand tight, do not tighten all the JCBC bolts.

ASSEMBLY INSTRUCTIONS

STEP 7

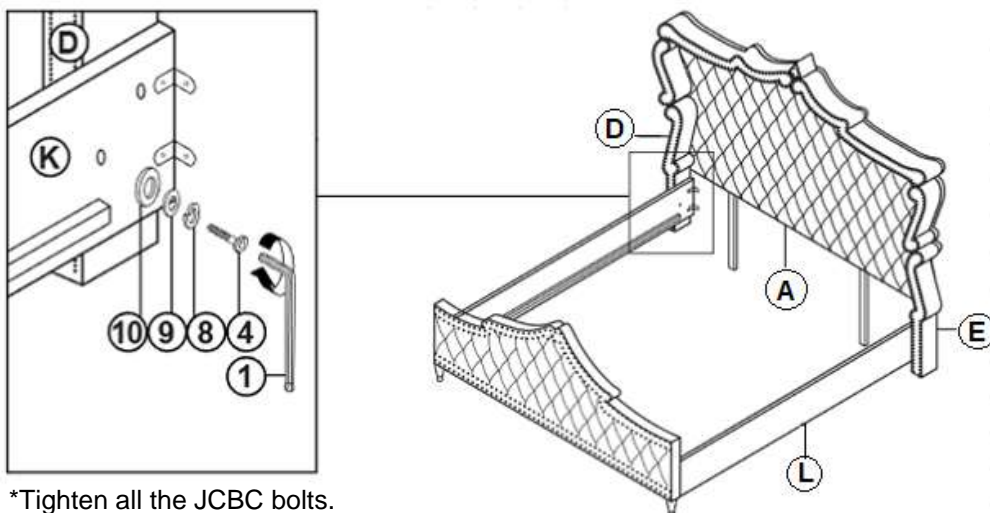

STEP 8

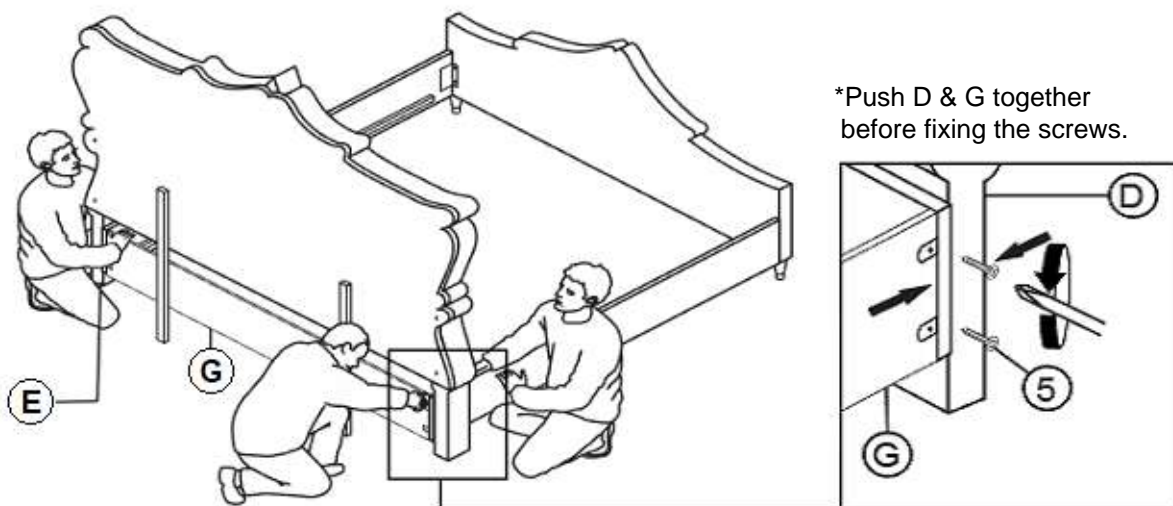

STEP 9

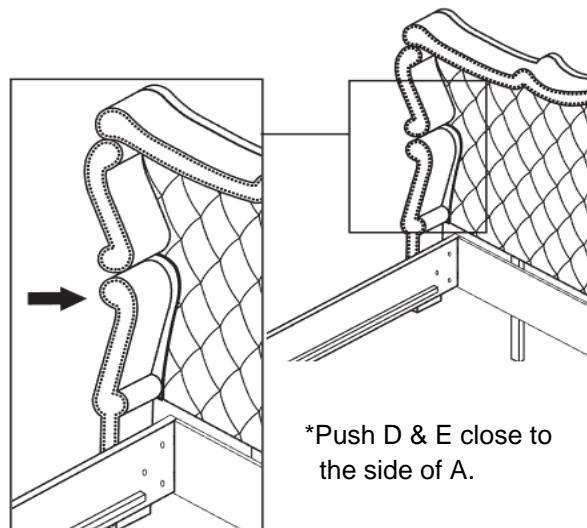

ASSEMBLY INSTRUCTIONS

STEP 10

* Tighten the JCBC bolts at D & E.

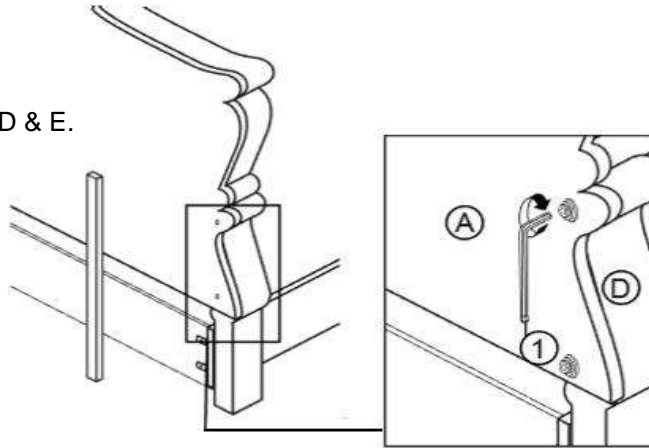

STEP 11

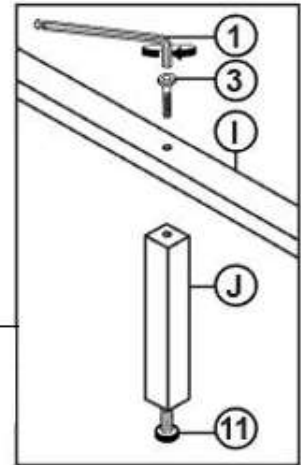
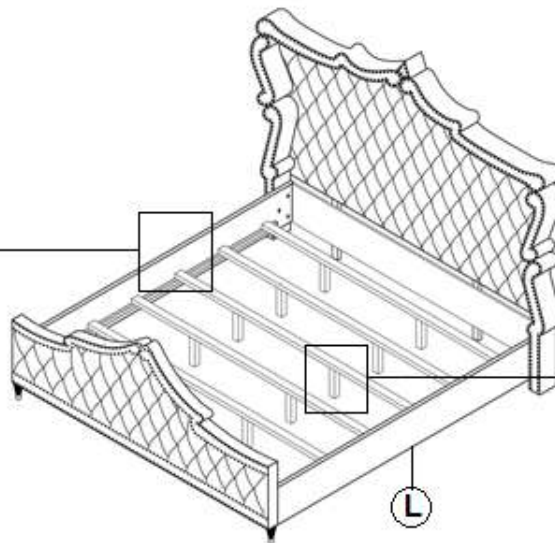
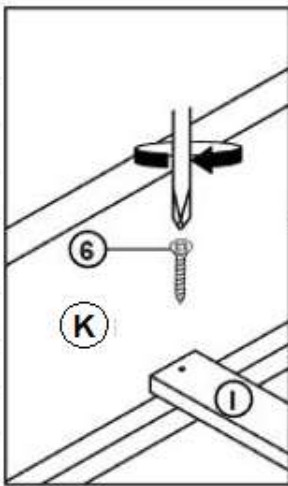

STEP 12 **COMPLETE**

