

STEEL TRUCK DOCKBOARD - TS-15-6066

APPROX WEIGHT: 490.79 lbs.
DOES NOT INCLUDE WEIGHT OF POWER OR PACKAGING!!!

*** ANY ADDITIONS, DELETIONS, OR OMISSIONS MUST BE CORRECTED ON THIS DRAWING AS THIS DRAWING WILL BE CONSIDERED ALL INCLUSIVE ***

ALL GRAPHICS PROVIDED ARE FOR REFERENCE ONLY. IF CERTAIN DIMENSIONS ARE CRITICAL PLEASE VERIFY THOSE DIMENSIONS WITH YOUR SALESPERSON

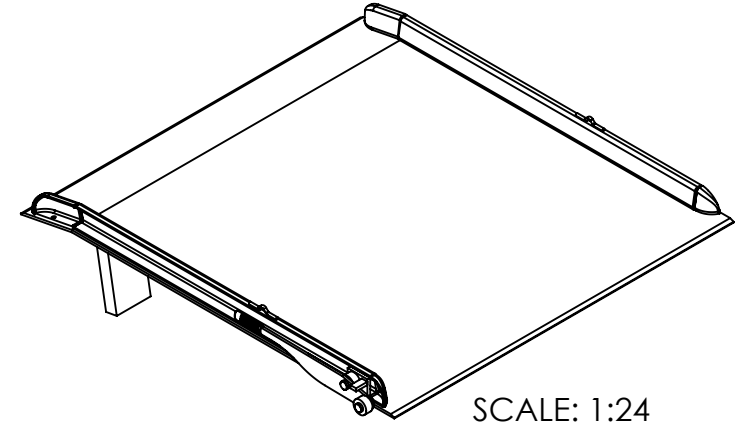
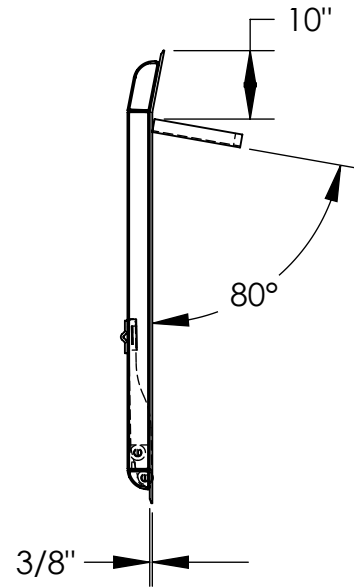
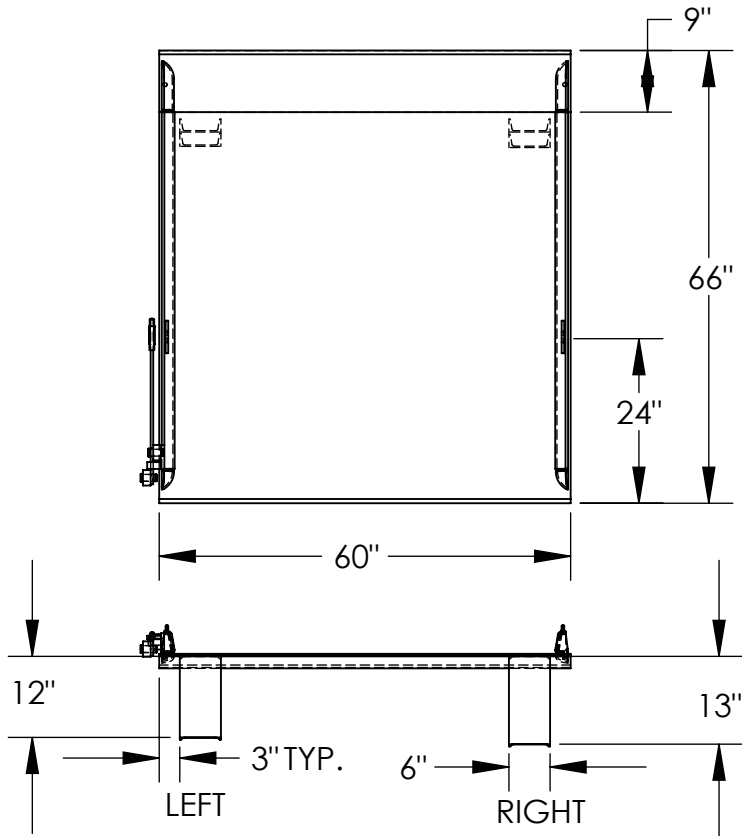

SCALE: 1:24

STANDARD FEATURES

- MODEL NUMBER: TS-15-6066
- CAPACITY: 15,000 LBS
- OVERALL WIDTH: 60"
- OVERALL LENGTH: 66"
- DOCKPLATE THICKNESS: 3/8"
- LEVER LIFT IS STANDARD
- LOCKING LEGS ARE 6" WIDE
- RIGHT LEG LENGTH IS 13"
- LEFT LEG LENGTH IS 12"
- CROWN IS 11° & 9" FROM EDGE

SPECIAL FEATURES

NONE

*OPTIONAL SPECIAL FEATURES

- OPTIONAL 2 PINS (10-112-001) & 2 CHAINS (1/4" CHAIN, 1,200 LBS 36" LONG, W/HOOK)

*AVAILABLE AT AN ADDITIONAL COST

APPROVAL	I, THE UNDERSIGNED, AGREE THAT THE PRODUCT AS REPRESENTED SATISFIES DESIGN AND DIMENSION REQUIREMENTS. I ALSO ACKNOWLEDGE MY DUTY TO CONFIRM PRODUCT AND INSTALLATION COMPLIANCE WITH ALL APPLICABLE FEDERAL, STATE AND LOCAL REGULATIONS AND STANDARDS.	
	ALL SPECIAL UNITS ARE NON-RETURNABLE [] As drawn [] As marked	
	Signed: _____	Date: _____
	LEAD TIME WILL START UPON RECEIPT OF SIGNED APPROVAL DRAWING	

DISTRIBUTOR'S NAME:		P.O.#
VESTIL MANUFACTURING		X
DRAWN BY: ADL		W.O.#
DATE: 12/21/05		X
REFERENCE: X	SCALE: 1:28	SALES: X
QUOTED LEAD TIME: X	QUOTE #	FILE NAME:
	X	10-007-040