

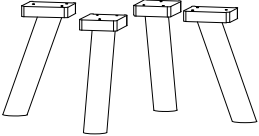



ASSEMBLY INSTRUCTION

CVFDR1001

PARTS

	DESCRIPTION		
A		Bottom	1
B		Legs	4

HARDWARE

	DESCRIPTION		
H1		bolts M6 x 45mm	12
H2		flat washers	12
H3		hex key #4	1

STEP - 1

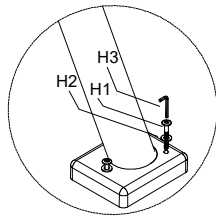
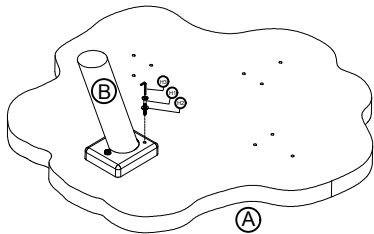

Attach the leg to its position
Insert bolt (H1) with and flat washers (H2) into the holes,
and tighten it with hex key #4 (H3)
Do the same to other legs

STEP - 2

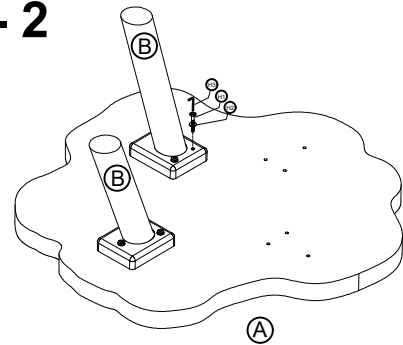

STEP - 3

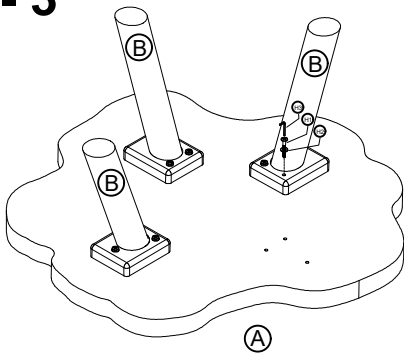

STEP - 4

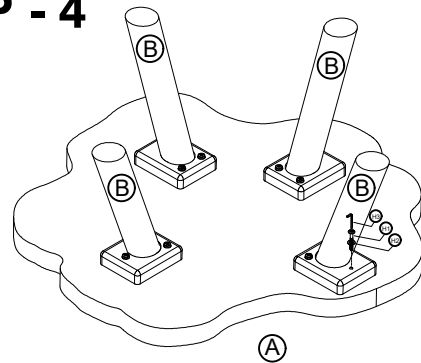

COMPLETED

