

ASSEMBLY INSTRUCTIONS & PARTS IDENTIFICATION

PARTS LIST

| Item | Code | Description | Qty |
|------|------|----------------|------|
| A | | Back cushion | 1PC |
| B | | Seat Cushion | 1PC |
| C | | Front Legs | 2PCS |
| D | | Rear Legs | 2PCS |
| E | | Floorglides | 4PCS |
| F | | Plastic washer | 4PCS |

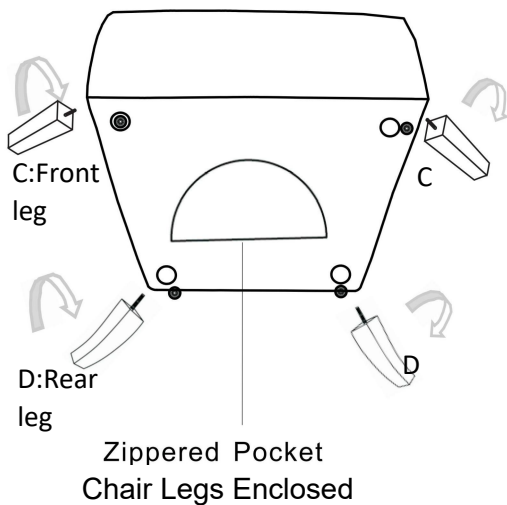
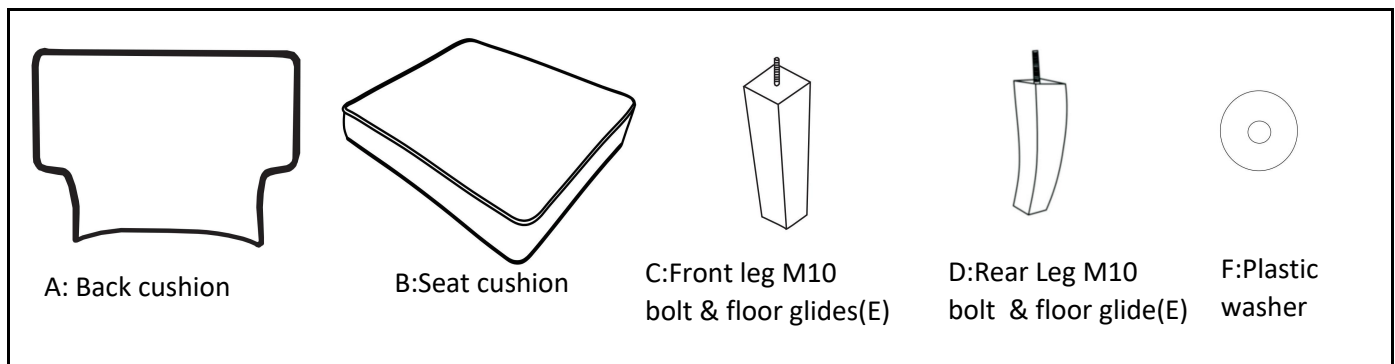
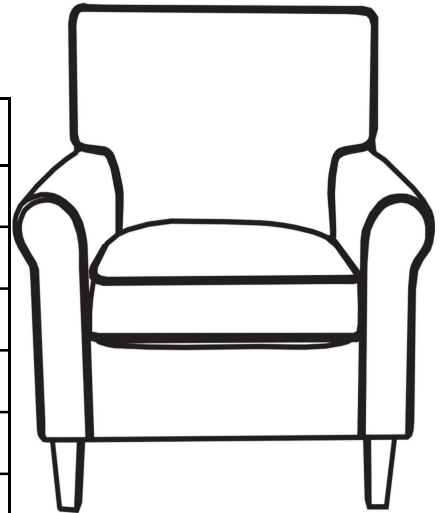

Assembly Steps:

- Step 1. Turn chair over on a clean flat surface.
- Step 2. Remove chair legs(item C&D) from zippered pocket at chair bottom.
- Step 3. Place plastic washer(Item F) onto the bolt on each leg.
- Step 4. Install the legs(item C & D) to chair.
- Step 5. Turn chair to its upright position.

*** Please note: To level chair you may need to add or remove washers from the particular legs.

FABRIC CARE INSTRUCTIONS REGULAR CARE

Clean only with a water-based shampoo or foam upholstery cleaner. Do not over wet. Do not use solvents to spot clean. Pile fabrics may require brushing to restore appearance. Cushion covers should not be removed and laundered.

**FABRIC CONTENT 100% POLYESTER -
CLEANING CODE "W"**