

Assembly Instruction

President Outdoor Dining Table

Your furniture requires assembly prior to use. It is important that you read the entire assembly instructions to become familiar with the unit before you set up this product.

Safety Warning and Precautions

WARNING: When setting up your furniture, basic precautions should always be followed to reduce risk of personal injury and damage to the product.

Read all instructions before assembly and usage this product.



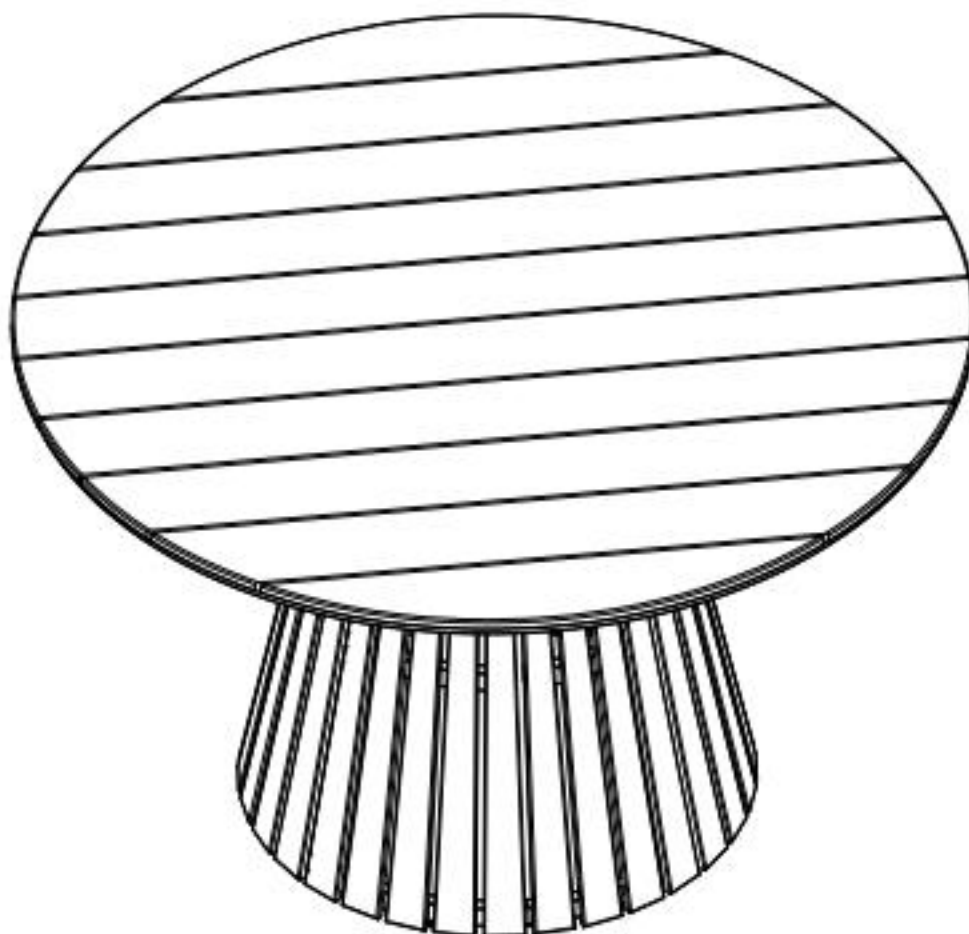



1. Select ideal location. Set out all parts on a clear and level surface prior to assembly. Ideally, the furniture should be set up in the desired location to avoid moving it after assembly.
2. Use caution. During all the processes of assembling, especially when lifting heavy or large parts, pay attention to safety.
3. Tools and Assistance. An adjustable spanner is required for assembly. It is recommended 2 people assist with assembly.
4. Check all parts before assembling, ensure you have all parts detailed in the parts list on Page 2.
5. Refer to assembly diagram. During assembly, refer to the assembly instructions on following pages.
6. Caution. Keep children away from work area during assembly. Do not allow children to handle parts or tools while assembling.



Assembly Instruction

President Outdoor Dining Table

FITTINGS IDENTIFICATION

Part #	M825	M640	M620	M655	X	Y	Z
Description:	Screw M8*25	Screw M6*40	Screw M6*20	Bolt M6*55	Gasket	Connector	Allen Wrench
Figure:	 M8*25	 M6*40	 M6*20	 M6*55	 Ø18*Ø8.5*1.5		
Qty:	4PCS	8PCS	18PCS	2PCS	32PCS	4PCS	2PCS

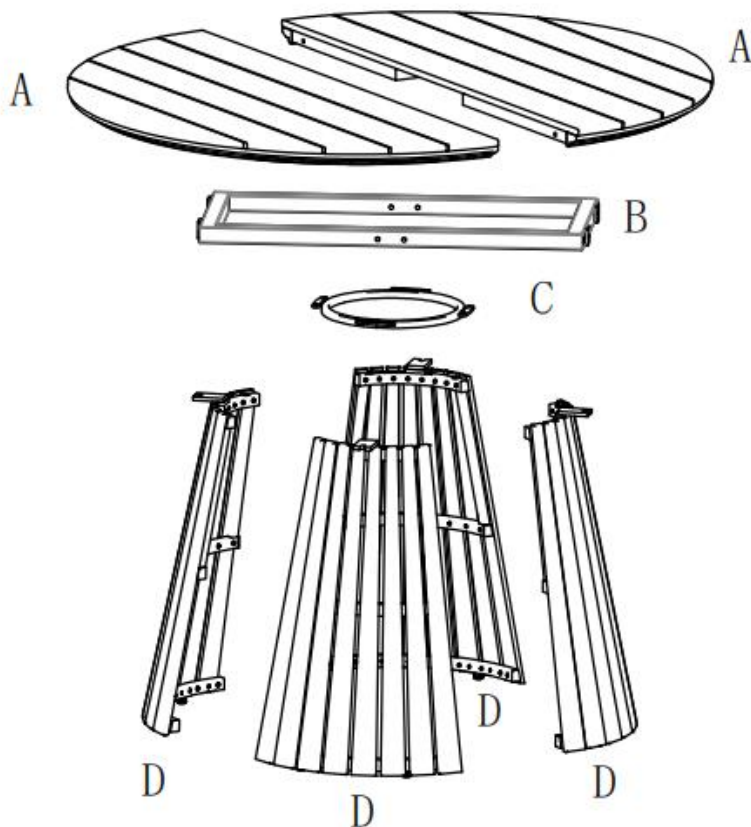
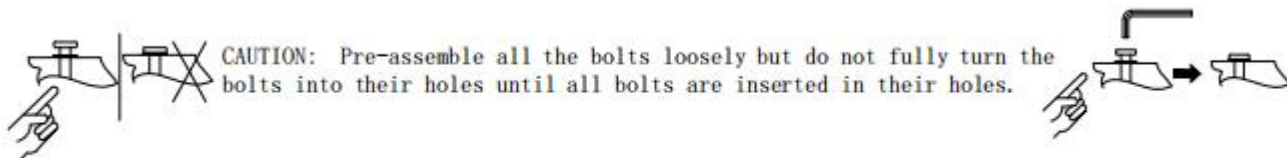

Assembly Instruction

President Outdoor Dining Table

STEP 1

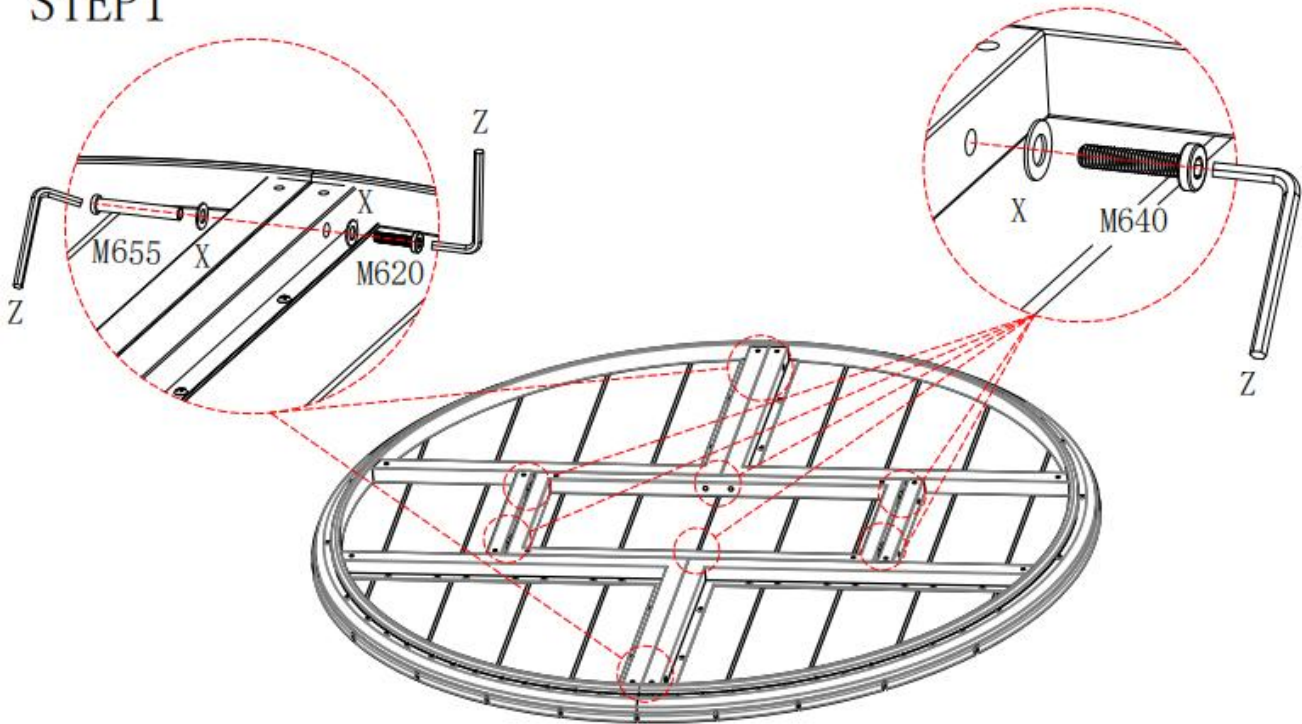

STEP 2

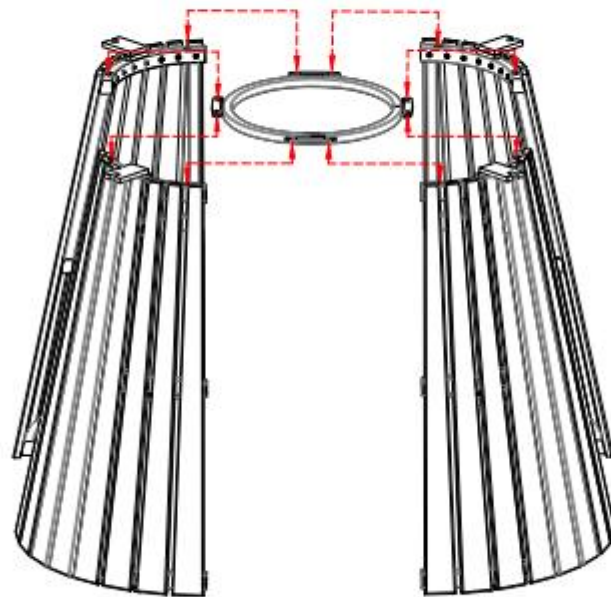

Assembly Instruction

President Outdoor Dining Table

STEP3

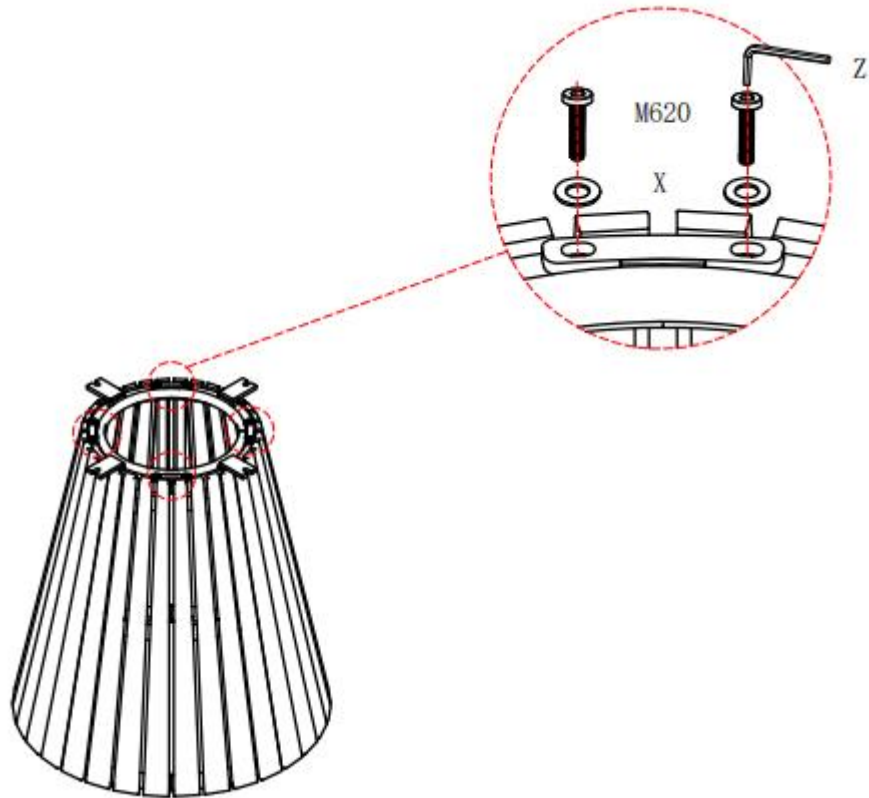

STEP4

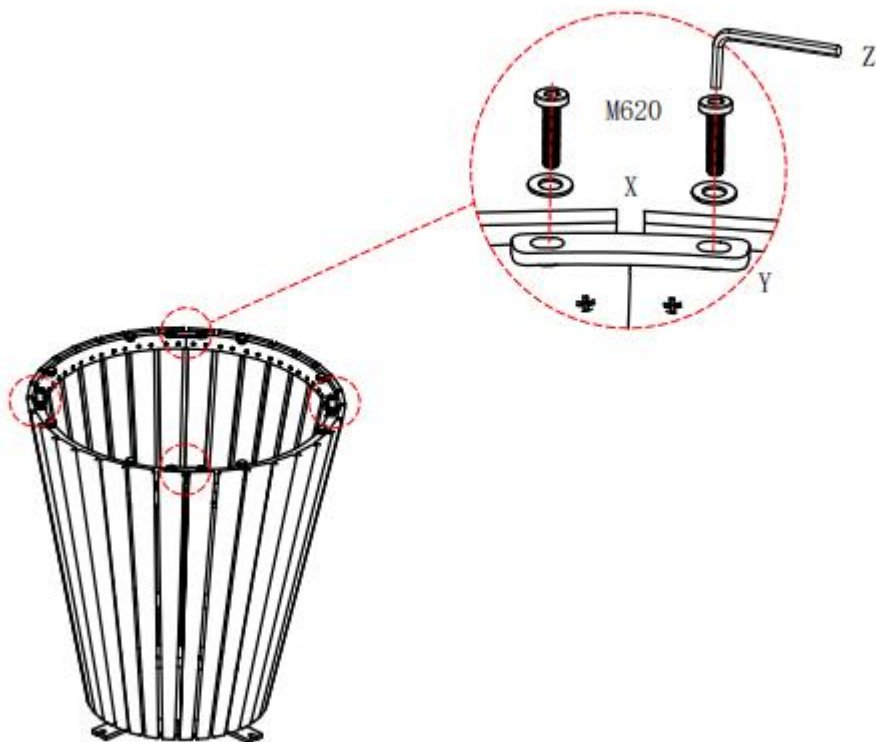

Assembly Instruction

President Outdoor Dining Table

STEP5

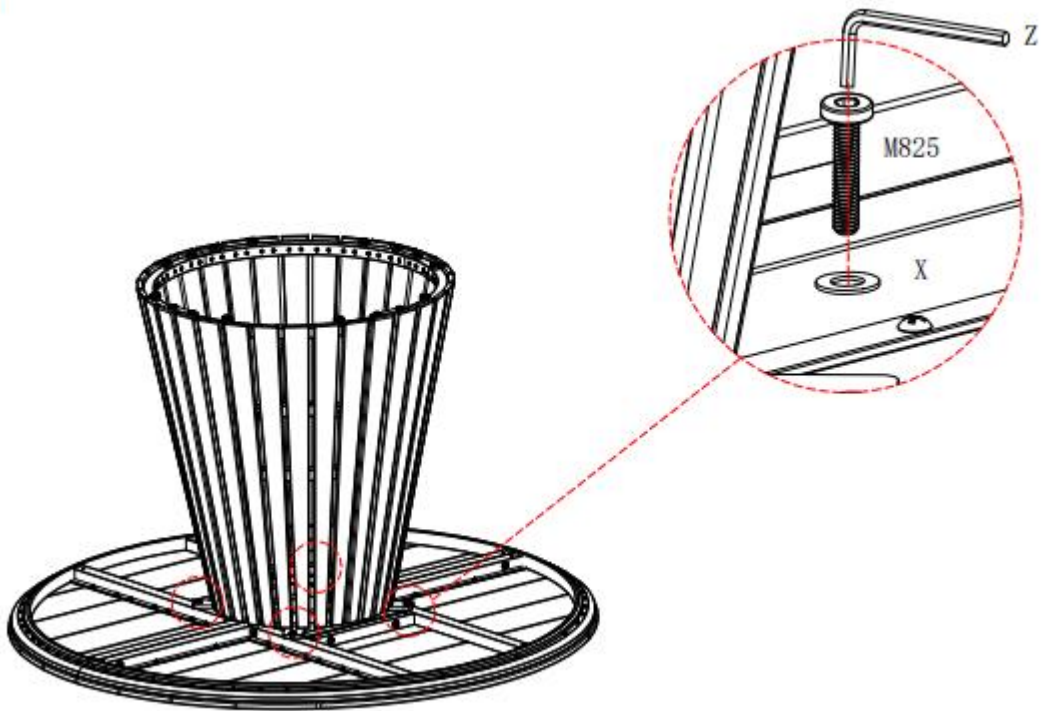

STEP6

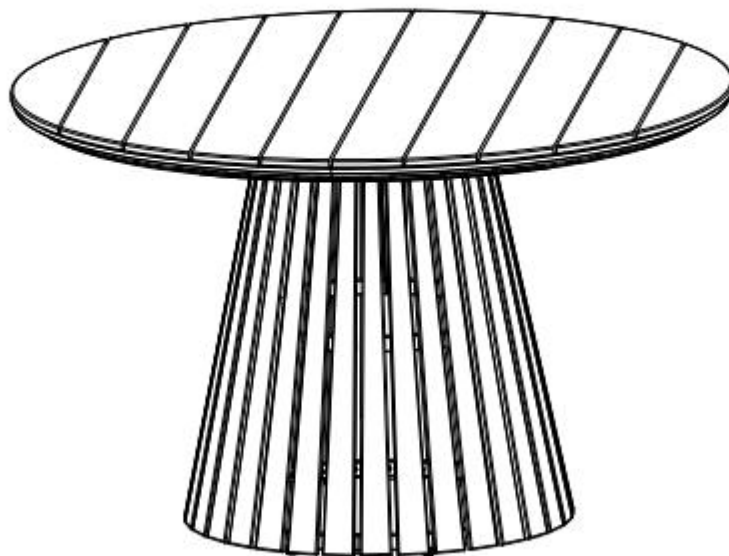

Assembly Instruction

President Outdoor Dining Table

Steps:

1. Attach the Table top connecting frame(Part B) to the Table Top (Part A) with Screw M6*40 (Part Part M640) and gasket (Part X) by using the Allen Wrench (Part Z) , Then install the Table top both side holes with Screw M6*55 & M6*20 (Part M655 & M620) and gasket (Part X) by using the Allen Wrench (Part Z)
2. Attach Connector (Part Y) the Table base connecting frame(Part C) to the Table base top (Part D) with Screw M6*20 (Part M620) & gasket (Part X) by using the Allen Wrench (Part Z)
3. Attach the Connector (Part Y) to the Table base bottom (Part D) with serew M6*20(Part M620) & gasket (Part X) by using the Allen Wrench (Part Z)
4. Attach the Table Base (Part D) to the Table Top with Screw M8*25 (Part M825) and gasket (Part X) by using the Allen Wrench (Part Z)

Tighten all screws. Your table is ready to use. (Note: Pre-assemble all the bolts loosely but do not fully turn the bolts into their holes until all bolts are inserted in their holes.)

Periodically check and make sure that all screws are fully tightened.