





ASSEMBLY INSTRUCTIONS & PARTS IDENTIFICATION TABLE

Thank you for purchasing this quality product. Be sure to check all packing material carefully for small parts that may have come loose inside the carton during shipment.

| Hardware kit | | | | Parts Key | | | |
|--------------|--|-------|--|-----------|------|-------------------|-------|
| No | Description | Q'Ty | | No | Code | Description | Q'Ty |
| A |  Bolt 1/4" x 1-1/2" | 8 pcs | | 1 | A | Table Top | 1 Pc |
| B |  Lock washer | 8 pcs | | 2 | B | Leg Assembly | 2 Pcs |
| C |  Flat washer | 8 pcs | | 3 | C | Side Stretcher | 2 Pcs |
| D |  Allen Key | 1 pc | | 4 | D | Table Floor Glide | 4 Pcs |

STEP 1

- Carefully place the Table Top on the smooth surface.
- Insert the two Leg Assemblies to Table Top with Bolts (A), Lock Washers (B) & Flat Washer (C) using Allen key (D). Do not tighten the bolts at this step. (See Detail A).

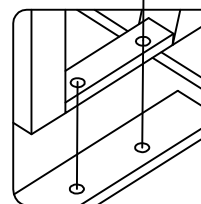
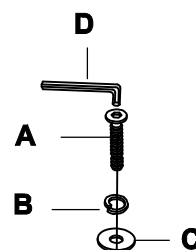
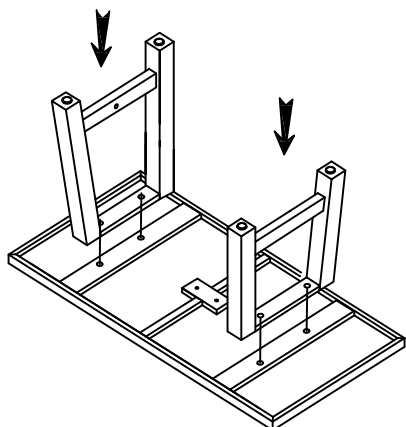

DETAIL A

STEP 2

- Attach the Side Stretcher to between the Leg Assembly and the Table Top with Bolts (A), Lock Washers (B) & Flat Washer (C) using Allen key (D). Tighten all bolts at this step. (See Detail B) & (See Detail C).

DETAIL B

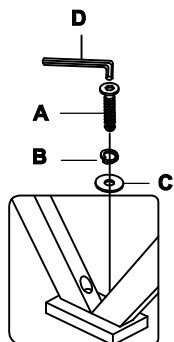
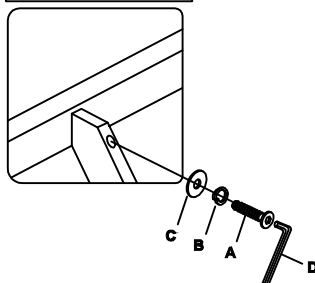

DETAIL C

