

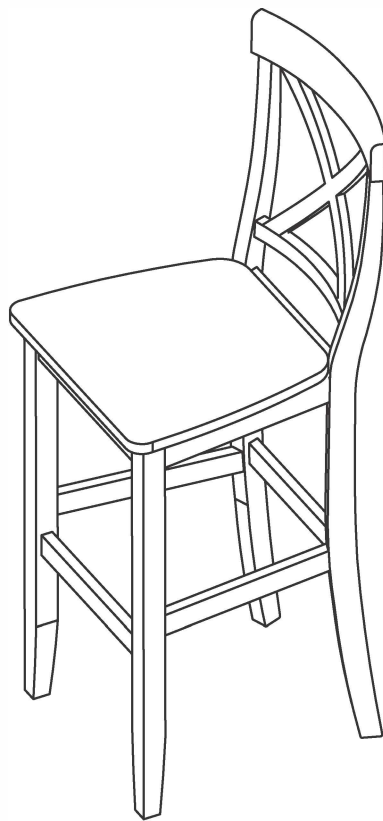

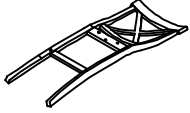

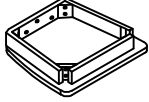

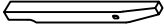

Bar Stool

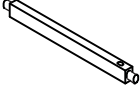

PART LIST

				
<p>Back Frame 2 PCS</p>	<p>Seat Frame 2 PCS</p>	<p>Front Leg (L & R) 4 PCS</p>	<p>Side Stretcher (L & R) 4 PCS</p>	<p>Front Stretcher 2 PCS</p>

HARDWARE LIST

 <p>1/4" x 80mm</p>	 <p>1/4" x 60mm</p>	 <p>1/4" x 40mm</p>		
<p>Long Bolt 8 PCS</p>	<p>Bolt 8 PCS</p>	<p>Short Bolt 6 PCS</p>	<p>Spring Washer 22 PCS</p>	<p>Flat Washer 22 PCS</p>
	 <p>4 x 38mm</p>			
<p>Allen Wrench 1 PC</p>	<p>Screw 12 PCS</p>			

ADDITIONAL TOOLS (Not Provided)

Note: It is not recommended to use power tools during assembly.



Phillips Head Screwdriver

Step 1. Attach seat frame (part B) to back frame (part A) using long bolts (part #1), short bolts (part #3), spring washers (part #4), flat washers (part #5) and allen wrench (part #6).

NOTE: Do not tighten bolts at this time.

NOTE: Please ensure you are using short bolts (part #3) in center to prevent damage to back frame (part A).

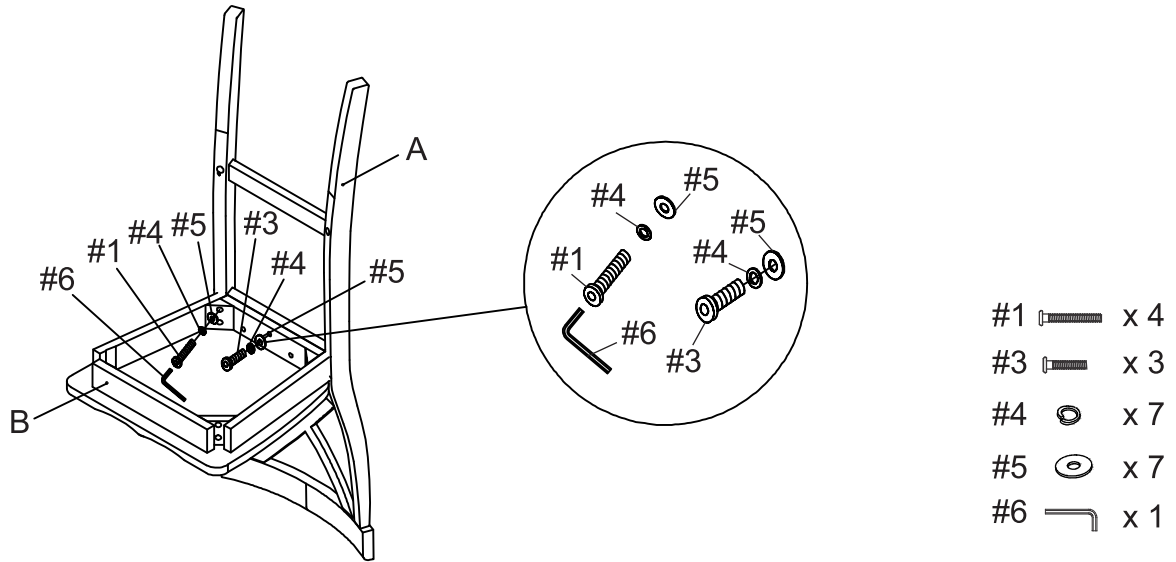

Step 2. Attach front legs (part C) to seat frame (part B) using bolts (part #2), spring washers (part #4), flat washers (part #5) and allen wrench (part #6).

NOTE: Do not tighten bolts at this time.

NOTE: The front legs (part C) are marked "R" for right and "L" for left.

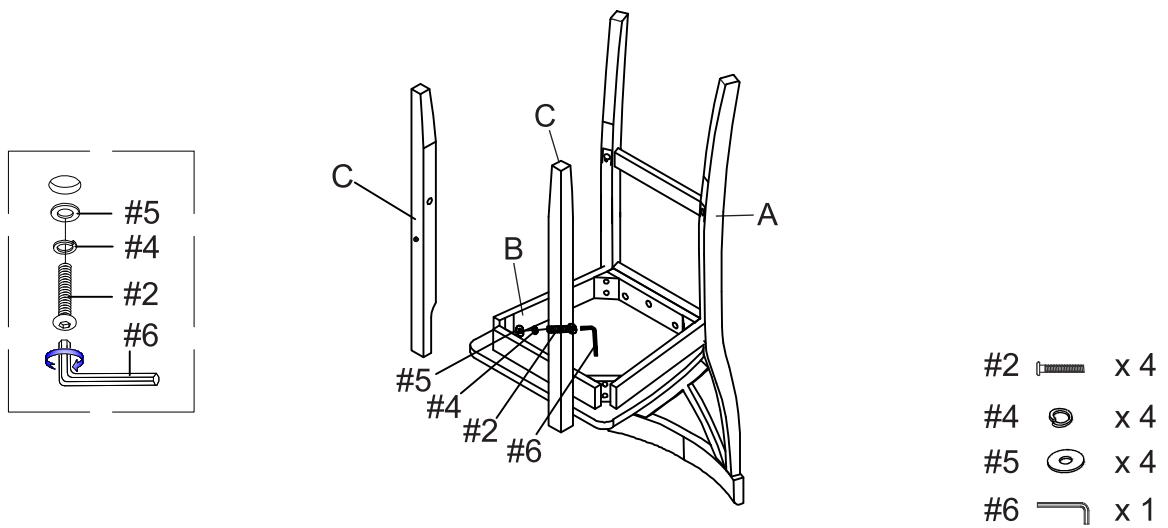

Step 3. Insert side stretchers (part D) into assembled unit (parts A & C). Insert front stretcher (part E) into front legs (part C).

NOTE: The side stretchers (part D) are marked "R" for right and "L" for left.

NOTE: If side stretchers (part D) are not flushed with back frame (part A) and front legs (part C), switch the front legs (part C).

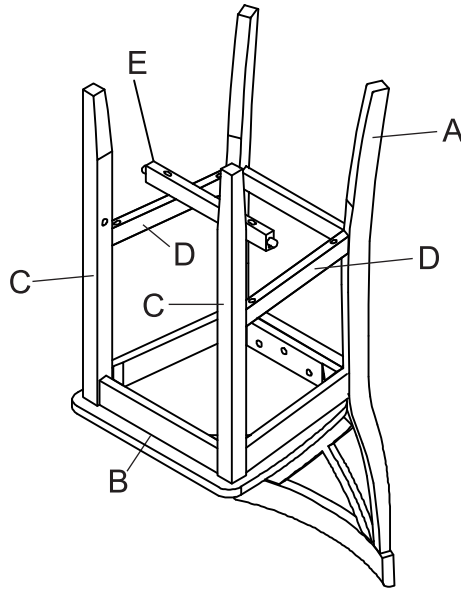

Step 4. Finger-tighten bolts (part #2), do not overtighten. Secure stretchers (parts D & E) using screws (part #7) and phillips head screwdriver.

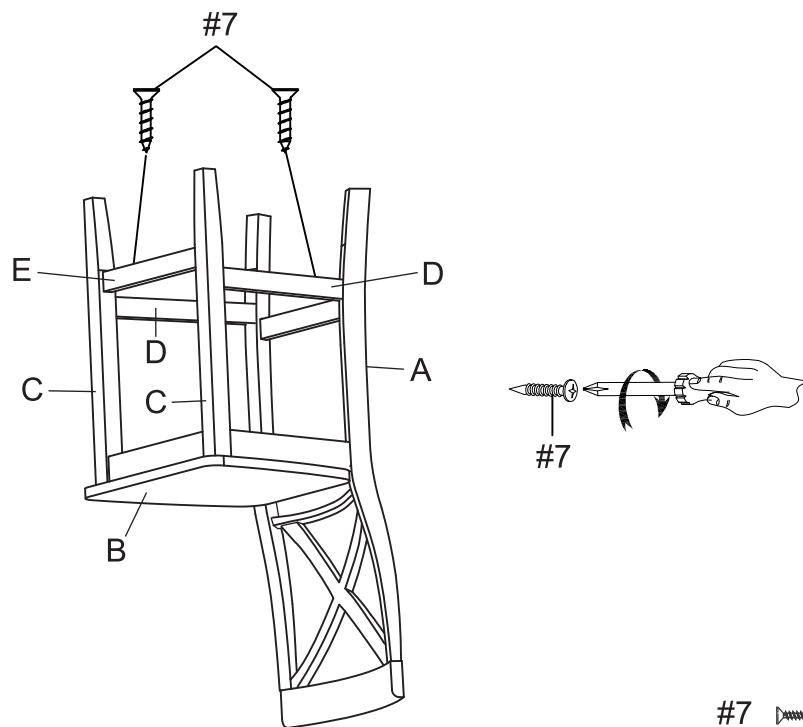

Step 5. Carefully turn unit upright. Ensure unit is leveled and square then tighten all bolts using allen wrench (part #6). Repeat steps 1-5 for remaining stool.

