



## FORNO COMMERCIAL 24" and 36" GAS HOTPLATE

**FCMHP0079-24 & FCMHP0079-36**



ANSI Z83.11 • CSA 1.8-(2016) Food Service Equip.  
Conforms to ANSI STD Z83.11-2016  
Certified to CSA STD 1.8-2016 Food Service Equip.  
CONFORMS TO NSF/ANSI 4:2020

# INSTRUCTION MANUAL

Read these instructions carefully before using your appliance, and keep it carefully.  
If you follow the instructions, your appliance will provide you with many years of good service.

## TABLE OF CONTENTS

Customer Care	4
Important Safety Notice	5
Attention Owners and Operators	6
Unpacking & Installation	7
Warnings and Safeguards for Operation	9
Operating Instructions	10
Cleaning Instructions	11
Troubleshooting	12
Conversion Kit Instructions for Gas Countertop Hot Plate	13
Warranty	15

**FORNO COMMERCIAL 24" and 36" GAS HOTPLATE**



**FCMHP0079-24 & FCMHP0079-36**

## Customer Care

Thank you for purchasing a Forno product. Please read the entire instruction manual before operating your new appliance for the first time. Whether you are an occasional user or an expert, it will be beneficial to familiarize yourself with the safety practices, features, operation and care recommendations of your appliance.

Both the model and serial number are listed inside the product. For warranty purposes, you will also need the date of purchase .

Record this information below for future reference.

Product Information	Service Information
Model Number : _____	
Serial Number : _____ _____ _____ _____ _____ _____ _____	
Date of Purchase : _____	
Purchase Address And Phone: _____ _____ _____	

**Service Information**

Use these numbers in any correspondence or services calls concerning your product.

If you received a damaged product, immediately contact Forno.

To save time and money, before you call for serviced, check the troubleshooting guide. It listed the causes of minor operation problems that you can correct yourself.



*“Need some quick help? Simply scan the qr code and get access to our fast support form. We’re always here to assist you with any questions or concerns you may have. So, don’t hesitate to reach out!”*

### Services in Canada and Untied States

Keep the instruction manual handy to answer your questions. If you don’t understand something or need more assistance, please visit our website for fast support. Please provide us your name, number, address,serial number of the product that troubleshooting, proof of purchase, and a short description of the issue. A customer service representative will contact you as soon as possible. All warranty work needs to be authorized by FORNO customer service. All our authorized service providers are carefully selected and rigorously trained by us.

# IMPORTANT SAFETY NOTICE

This manual contains important safety instructions which must be strictly followed when using this equipment. Please retain this manual for future reference.

## FOR YOUR SAFETY

*Do not store or use gasoline or other flammable vapors or liquids in the vicinity of this or any other appliance.*

**WARNING:** Improper installation, adjustment, alteration, service or maintenance can cause property damage, injury or death. Read the installation, operating and maintenance instructions thoroughly before installing or servicing this equipment.

# Attention Owners and Operators

The equipment is designed to provide safe and productive processing, cooking and warming of food products as long as the equipment is used in accordance with the instructions in this manual and is properly maintained. Unless the operator is adequately trained and supervised there is a possibility of serious injury. Owners of this equipment bear the responsibility to make certain that this equipment is used properly and safely, and to strictly follow all of the instructions contained in this manual and the requirements of local, state or federal law.

Owners should not permit anyone to touch this equipment unless they are over 18 years old, are adequately trained and supervised, and have read and understood this manual. Do not attempt to repair or convert any gas types on your own. Repairs and conversions are to be made solely by an authorized local servicer. Owners should also ensure that no customers, visitors or other unauthorized personnel come in contact with this equipment. Please remember that supplier cannot anticipate every circumstance or environment in which its equipment will be operated. It is the responsibility of the owner and the operator to remain alert to any hazards posed by the function of this equipment. If you are ever uncertain about a particular task or the proper method of operating this equipment, ask your supervisor.

This manual contains a number of precautions to follow to help promote safe use of this equipment. Throughout the manual you will see additional warnings to help alert you to potential hazards.

## Warnings affecting your personal safety indicated by:



OR



## Warnings affecting your possible damage to the equipment and property are indicated by:



If any warning labels or this manual are misplaced, damaged, or illegible, or if you require additional copies, please contact your nearest representative or vender directly for these items at no charge.

Please remember that this manual or the warning labels do not replace the need to be alert, to properly train and supervise operators, and to use sense when using this equipment.

Model	Gas	Number Of Burners	BTU/hr Input Rating
24" -4 burner	Natura/LP	4	104,000
36" -6 burner	Natura/LP	6	156,000

# Unpacking & Installation



## TO AVOID SERIOUS PERSONAL INJURY AND PROPERTY DAMAGE:

- **ALWAYS** install equipment in a work area with adequate light and space.
- **ONLY** operate on a solid, level, nonskid surface that is nonflammable and away from sinks and water hazards.
- **NEVER** bypass, alter or modify this equipment in any way from its original condition. Doing so may create hazards and will void warranty.

## GAS and GAS PRESSURE



**This unit is factory supplied in Natural Gas.** This unit can be converted to L.P. gas by a licensed and certified gas technician, Documentation may be necessary for warranty issues. Failure to comply with this instruction, will void warranty.

**See the included L.P. conversion kit for gas conversion parts and instructions.**



Unit installation must conform with the National Fuel Gas Code, ANSI Z223.1/NFPA 54, the National Gas Installation Code, CSA-B149.1, or the Propane Installation Code, CSA-B149.2 as applicable and in accordance with local codes.



The appliance and it's individual shutoff valve (to be supplied by user) must be disconnected from the gas supply piping system during any pressure testing of that system at test pressures in excess of ½ psi (3.45 kPa).



These models are designed, built, and sold for commercial use only.



Instructions must be posted in a prominent location. All safety precautions must be taken in the event the user smells gas. Safety information can be obtained from your local gas supplier.

## UNPACKING

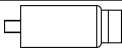
Unpack the hot plate immediately after receipt. Remove the gas hot plate from the crate; remove all packaging on and surrounding the unit and be certain to remove all protective plastics and residues from all surfaces. Make sure that all parts provided including the L.P. gas conversion kit are located.

If the machine is found to be damaged, save the packaging material and contact the carrier within fifteen (15) days of delivery. Immediately contact CORE PRO or your local dealer of the equipment. **You have no recourse for damage after fifteen (15) days.**

No.	Accessory	Q'TY	Fig
1	Adjustable feet	4	
2	Regulators	1	
3	FCMHP0079-24 orifice	4	

No.	Accessory	Q'TY	Fig
4	FCMHP0079-36 orifice	6	
5	tray	1	

# Unpacking & Installation

## INSTALLATION

1. Read this manual thoroughly before installation and operation. DO NOT proceed with installation and operation if you have any questions or do not understand anything in this manual. Contact your local representative.
2. Select a location for the hot plate that has a level, solid, nonskid surface that is nonflammable and away from water hazards or sinks, and is in a well-lighted work area away from children and visitors.
3. Equipment must be installed under proper ventilation as required per local code.  
NOTICE: Local codes regarding installation and ventilation vary greatly by area. The National Fire Protection Association, Inc, states in its NFPA 96 latest edition (see NFPA page at the beginning of this manual) that local codes are “authority having jurisdiction” when it comes to requirements for installation of equipment. Therefore, installation should comply with all local codes.
4. This appliance is equipped for Natural gas, for conversion to LP gas please see another conversion kits instruction.
5. Screw legs into the permanently fastened nuts on the four corners of the unit and tighten by hand. Legs must be installed to adequately provide proper ventilation to the unit.
6. Level unit by adjusting the four feet and tighten securely. The adjustable feet have an adjustment of one inch for lineup with other countertop lines. Do not slide unit with legs mounted, lift if necessary to move unit.
7. The supplied gas pressure regulator is factory set at 4" Natural gas W.C. or 10" for L.P.
8. THESE UNITS ARE SUITABLE FOR INSTALLATION ON NON-COMBUSTIBLE SURFACES ONLY.  
Noncombustible clearances: 0" sides (0 mm) 6" rear (152 mm) 4" floor (102 mm)
9. Do not obstruct the flow of combustion and ventilation air, under the unit by the legs or behind the unit by the flue. Do not place objects between the bottom of the unit and the counter top.
10. There must be adequate clearance for removal of the front panel. All major parts except the burners are removable thru the front if the gas line is disconnected.
11. It may be necessary to adjust the balance of gas volume and air supply to each burner. This must be done by an authorized service technician.
12. Pipe threading compound must be resistant to the action of liquefied petroleum gases.



DO NOT use an open flame to check for leaks. Check all gas piping for leaks with a soap and water solution before operating unit.

## COMMISSIONING:

Commissioning of your new hot plate is of the utmost importance. Commissioning is the thorough and methodical testing of the equipment, sub systems, and systems to ensure that the final product functions properly and safely at the work site. By identifying any potential problems (i.e.: equipment location, ventilation, local fire/electrical codes, installation, operator training and certification) prior to equipment being placed into service, costly outages and potential damages may be avoided.

# Warnings and Safeguards for Operation



## TO AVOID SERIOUS PERSONAL INJURY AND PROPERTY DAMAGE:



For your safety, do not store or use gasoline or other flammable vapors or liquids in the vicinity of this or any other appliances. Keep the area free and clear of combustible. ( See ANSI Z83. 14B, 1991).



Improper installation, adjustment, alteration, service or maintenance of this equipment can cause property damage, personal injury, or death and voids warranty. Read the installation operating and maintenance instructions thoroughly before installing, or operating this equipment.



Instructions must be posted in a prominent location. All safety precautions must be taken in the event the user smells gas. If you smell gas, immediately shut off the main gas valve, extinguish all heat and flames, and call 911. Safety information can be obtained from your local gas supplier.

## IMPORTANT SAFEGUARDS & SAFETY INSTRUCTIONS



When using gas cooking equipment, basic safety precautions should always be followed, including the following:

The hot plate burners, cooking grates and outside surfaces may become HOT after use. Use caution when touching the unit.

- Never directly touch the burners or cooking grates while the hot plate is on.
- Always turn off the unit when not in use, servicing or adjusting any parts or attachments, and before cleaning.
- Never leave the hot plate on overnight.
- Do not operate any equipment with a damaged or leaking gas line, ignitor or valves or if the unit is dropped or damaged in any manner. Call for service.
- The use of attachments not recommended or sold by the manufacturer may cause fire, injury or even death.
- Do not use outdoors.
- Do not use this equipment for any use other than the use intended by the manufacturer.
- Never use the hot plate as a heating source
- The hot plate does not contain any user-serviceable parts. Dealers or recommended qualified technicians should carry out repairs. Do not remove any components or service panels on this product.
- Never bypass, alter, modify or attach any unauthorized parts to this equipment. Doing so may create hazards and will void warranty
- Supplier takes every care to ensure that all products are safe. Steel cutting procedures used to manufacture these items result in sharp edges. These sharp edges are removed to the best of our ability; however, we insist the operator take care when in contact with this piece of equipment.
- Always keep hands, hair and clothing away from heating source.
- Allow the hot plate to cool down after use and before dismantling for cleaning; the unit will be too hot to handle immediately after use.

# Operating Instructions

## **Operating the Hot Plate - Pilot Lighting Instructions**

Before operating hot plate, it should be checked to see that it is sitting level. Adjust the feet to level the hot plate. Be sure the catch tray has been properly placed.

The pilot lights on the appliance have been set at the factory. Each burner has a pilot light.

1. Make sure all knobs are in the "OFF" position.
2. The main gas valve should be "CLOSED/OFF" for five (5) minutes prior to lighting pilots to clear any existing gas. (Main gas valve is supplied by others.)
3. Turn "ON/OPEN" the main gas valve to the unit.
4. Light and hold an ignition source (match) at the pilots. When the flame is established, remove the ignition source. Repeat this step for each burner as each burner has its own individual pilot. The pilot can be reached through the holes in the front of the unit.
5. Adjust the pilot valve, make sure the pilot flame at 1/2 inch height.
6. Turn each burner knob "ON". If the burners do not ignite promptly, turn the knobs "OFF". From the opening in the front panel, use a screwdriver and turn the pilot valve screw counterclockwise which will increase the flame height and repeat step 4.

The pilot flame should be as small as possible but large enough to guarantee reliable ignition of the burners when the knobs are turned to "ON". The holes located in the front panel are pilot valve adjustments. Use a screwdriver to turn the valve to adjust the flame height to your desired level.

## **Igniting the Burner**

To ignite the burner, turn knob to the "ON" position. Then back off to the desired flame level. The range of adjustment is virtually infinite between "ON" and "OFF".

The space between the legs at the bottom admits combustion air. **DO NOT BLOCK THIS SPACE.**

All burners are lit from constantly burning pilots. Turning the valve to the desired flame height is all that is required to put the unit in service.

Do not permit fans to blow directly at the unit. Wherever possible, avoid open windows next to the unit's sides or back. Avoid wall type fans which create air cross-currents within a room.

It is also necessary that sufficient air should be allowed to enter the room to compensate for the amount of air removed by any ventilating system. Otherwise, a subnormal atmospheric pressure will occur, affecting operation and causing undesirable working conditions.

A properly designed and installed hood will act as the heart of the ventilating system for the room or area in which the unit is installed, and will leave the unit independent of changing draft conditions.

NOTE: It may be necessary to adjust the balance of gas, volume and air supply to each burner. This must be done by an authorized service technician.

## **Shutdown burner**

To turn 'OFF' the appliance completely, turn the gas control knob completely clockwise to the 'O' position, the pilot burner will extinguish.

# Cleaning Instructions



**DO NOT use any abrasive or flammable cleaning fluids.**

**DO NOT hose down, immerse or pressure wash any part of the hot plate, excluding the catch tray.**

**NEVER use a scrubber pad, steel wool or abrasive material, or cleaners containing chlorine, iodine and ammonia or bromine chemicals as these will deteriorate the stainless steel and shorten the life of the unit.**



**IF CLEANING THE BURNER OF THE HOT PLATE, THE MAIN GAS VALVE MUST BE SWITCHED TO THE CLOSED POSITION. AFTER CLEANING, THE GAS LINE CAN BE SWITCHED BACK TO THE OPEN POSITION. PLEASE FOLLOW THE LIGHTING INSTRUCTIONS IN THIS MANUAL TO RELIGHT THE HOT PLATE'S PILOT LIGHTS.**

## RECOMMENDED CLEANING

It takes very little time and effort to keep the hot plate attractive and performing at top efficiency. Please follow the cleaning steps below:

PART	REQUIRED ACTION	FREQUENCY
Grates	Wash with soap and water.	Daily
Body	Use a clean cloth and a non-abrasive cleaner to clean the stainless steel body of the hot plate. Wipe the polished areas with a soft cloth.	Daily
Controls	Unit should be turned off when not in use. It is recommended that the unit be disconnected from the gas supply by closing the main gas valve. Use a clean cloth to wipe any down controls and/or knobs	Daily
Catch Tray	Once the unit has cooled, remove the catch tray and discard the waste, debris and crumbs. CAUTION: If the catch tray is permitted to fill too high, debris is likely to accumulate under the unit. The catch tray/drawer is removed by pulling forward. USE CAUTION WHEN REMOVING!	per Use or at least Daily
Burner Air Shutter Openings	Main burner ports must be kept clean. Close the gas valve to the unit shutting of the gas and extinguishing the pilot light. Clean in place with a wire brush or clean gas ports with a sharp-pointed metal instrument to insure open ports or the burners may be removed and washed in soapy water for 15-20 minutes.	As needed
Regulator	Make sure the vent opening is open and not blocked in any way. Failure to do so will cause variations in pressure. Your unit will not function as well and it could shorten the life of the product.	Monthly

# Troubleshooting

ISSUE	CAUSE	SOLUTION
Hot plate not lighting	Main gas line is closed	Open valve
	Pilot light is not lit	Ignite pilot light
	Cause unknown	Call for service
Flame is too high or too low	Adjustment knob is turned up or down	Adjust flame with control knob
Pilot light not staying lit	Flame is too low	Adjust pilot light flame height
	Pilot tube clogged	Replace pilot tube. Call for service
Strong smell of gas in cooking area	Main gas line leak	Turn off main gas valve. <b>DO NOT LIGHT FLAME</b> , ignite anything, or turn/switch on anything electrical Call fire department if needed and call for service
Cooking surface is heating up slowly	Carbon build up	Ensure that the burners are kept clean and free from carbon build up/ debris
Gas type of Unit needs to be converted	Unit ships from the factory Natural gas. Conversion from Natural Gas to L.P. is possible for this unit	Contact an authorized servicer. Do not attempt conversion on your own

If problems persist and the assigned solution does not remedy the issue, please call Service Department or your local service company.

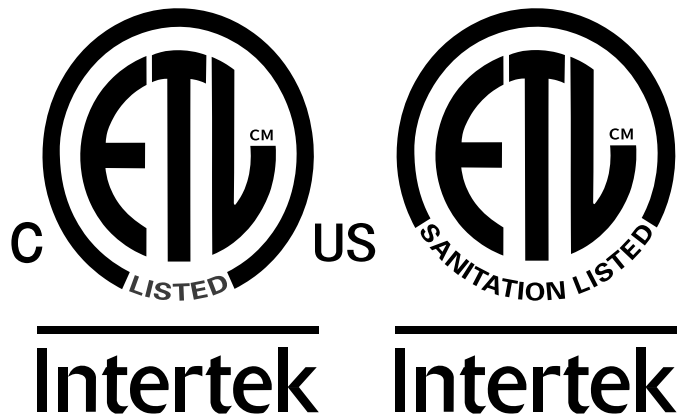

# Conversion Kit Instructions for Gas Countertop Hot Plate

Models: 24" -4 burners 36" -6 burners

## IMPORTANT SAFETY NOTICE

These conversion instructions are for conversion of the HOT PLATE. The instructions provide in this kit are for the conversion of Natural Gas to L.P. gas and refer to the conversion of the unit and kit provided. An authorized licensed technician must be called to perform the complete conversion of the unit. Failure to properly convert this unit, can result in serious injury, property damage or death and will void warranty.

## Hot plate Conversion Kit Instructions



Do not attempt gas conversion by yourself. Gas conversion of your unit is to be made by a certified/licensed technician.

### CONVERSION

Instructions are for conversion from Natural Gas to Propane (L.P.) on all models. The conversion should be done before connecting the unit to the gas supply. Units are shipped from the factory equipped for use on natural gas. Parts necessary for L.P. (liquid propane) are provided with the unit. Turn off the main gas supply before doing any maintenance.

1. Remove the top grate

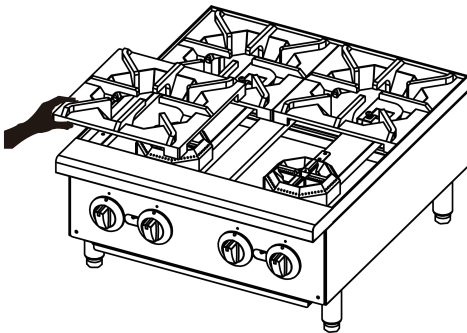

2. Raise the top burner and pull, Exposed the orifice.

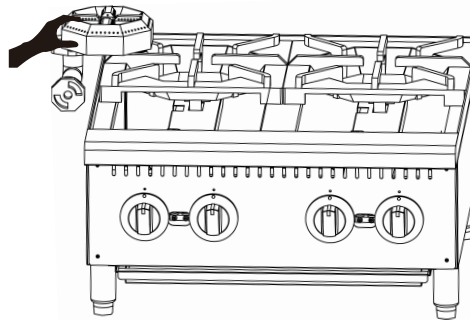

3. Loosen orifice by hex wrench.

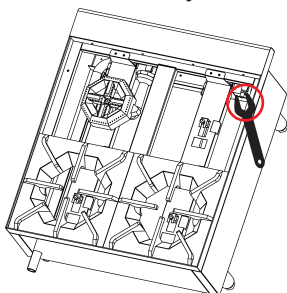

4. Replace the orifice fittings into the valve  
Note: Unit Number on side of orifice fittings

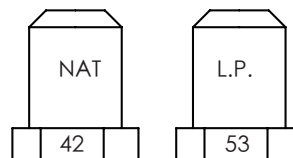

## Conversion Kit Instructions for Gas Countertop Griddle(continued)

5. Put back top burner, Caution: air shutter must be toward orifice.

6. Put back top grate.

7. Before installing the included convertible regulator, unscrew the octagon cap. You can read (NAT) on the plastic insert attached to the head of the cap; flip it over and snap back in place.

Pictured is the plastic insert. Pull off insert from octagon cap and reverse the plastic insert position so that the L.P. position is attached to the octagon cap head.

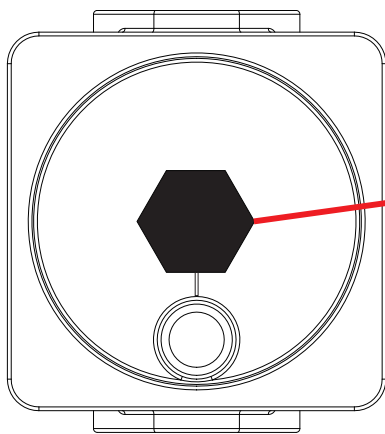

Convertible regulator with octagon cap. Unscrew from regulator.

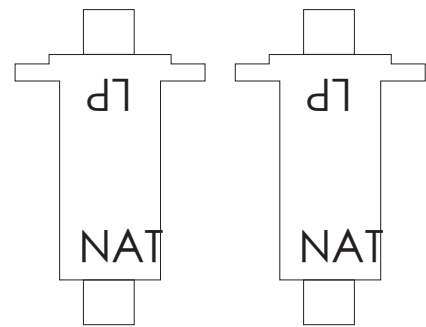

L.P. Position of insert. Regulator is now converted to L.P.

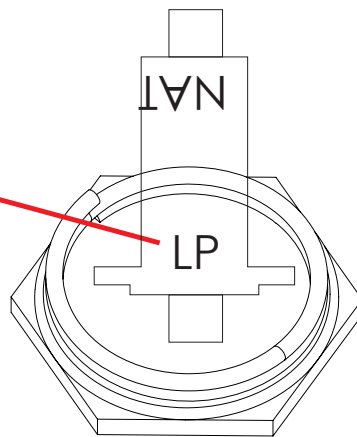

L.P. Position

8. Check all joints in the gas supply line for leaks. use soap and water solution. do not use an open flame.

9. Continue with installation.

## Warranty

---

### What this limited warranty covers:

- This limited warranty provided by Forno Appliances applies exclusively to the original Forno appliance (“Product”) sold to the original purchaser (“Purchaser”) by an authorized Forno dealer, distributor, or retailer, and installed in the United States or Canada. The Product must remain within the country of original purchase.
- This warranty is valid for a period of one (1) year from the date of original retail purchase and covers parts and labor.
- This warranty is strictly limited to commercial use. Any residential use of the Product will void this warranty.
- Forno Appliances will repair or replace, at its discretion, any component or part that proves to be defective due to manufacturing defects in materials or workmanship under normal commercial use during the warranty period. Repair or replacement will be performed by a Forno Authorized Service provider during normal working hours.
- This warranty does not cover installation, misuse, abuse, improper maintenance, or normal wear and tear. The Purchaser is responsible for ensuring the Product is reasonably accessible for service.
- Warranty coverage is non-transferable. In the event of replacement of parts or the entire Product, the replacement will assume the remaining warranty period from the original purchase date. The warranty period will not be extended.

### Important

Retain proof of original purchase to establish the warranty period. Forno’s liability on any claim of any kind, with respect to the goods and/or services provided, shall in no event exceed the value of the product, service, or part thereof which has given rise to the claim.

### 30-Day Cosmetic Warranty

The Purchaser must inspect the Product at the time of delivery. Forno warrants that the Product is free from manufacturing-related cosmetic defects in materials and workmanship for a period of thirty (30) days from the date of original retail purchase.

This coverage includes:

- Paint blemishes
- Chips
- Visible finish defects

### Cosmetic warranty does NOT cover:

- Damage resulting from improper transportation, handling, or installation (including dents, warping, deformation, or damaged components, cracked or damaged glass components)
- Minor color variations in painted or enameled parts
- Differences caused by lighting conditions, installation location, or similar factors
- Stains, corrosion, or discoloration caused by external substances or environmental conditions
- Labor costs
- Display models, floor models, B-stock, open-box, “as-is” products, or demo units

### What Exclusion: What is not covered

- Installation services at the time of purchase or during product replacement.
- Use of the Product in any residential or non-commercial application
- Use of the Product for purposes other than its intended use
- Service or repairs performed by anyone other than a Forno Authorized Service provider
- Damage or repair services required to correct work performed by unauthorized parties or the use of unauthorized parts.
- Installation not in accordance with local/state/county fire codes, electrical codes, gas codes, plumbing codes, building codes, laws or regulations.
- Defects or damage due to improper storage of the Product.
- Defects, damage or missing parts on products sold out of the original factory packaging or from displays.
- Service calls or repairs to correct an incorrect installation of the Product and/or related accessories.
- Replacement of parts/service calls to connect, convert or otherwise repair the electrical wiring and/or gas line in order to properly use the product.
- Replacement of parts/service calls to provide instructions and information on the use of the Product.
- Replacement of parts or service calls to correct issues arising from use of the Product in a manner inconsistent with normal and customary commercial use.
- Replacement of parts/service calls due to wear and tear of components such as seals, knobs, pan supports, shelving, cutlery baskets, buttons, touch displays, scratched or broken ceramic-glass tops.
- Replacement of parts/service calls for lack of/improper maintenance, including but not limited to: build up of residues, stains, scratches, discoloration, corrosion.
- Defects and damages arising from accidents, alteration, misuse, abuse or improper installation.
- Defects and damages arising from Product transport, logistics and handling. Inspection of the product must be made at time of delivery. Following receipt and inspection, the selling dealer/delivery company must be notified of any issues arising from handling, transport and logistics.
- Defects or damage resulting from external forces beyond the control of Forno Appliances, including but not limited to wind, rain, sand, fire, flooding, mudslides, freezing temperatures, excessive moisture or prolonged exposure to humidity, power surges, lightning, structural failures surrounding the appliance, or other natural phenomena.
- Products whose serial number has been altered/damaged/tampered with. In no case shall Forno be held liable or responsible for damage to surrounding property, including furniture, cabinetry, flooring, panels, and other structures surrounding the Product. Forno is neither liable nor responsible for the Product if it is located in a remote area or an area where certified trained technicians are not reasonably available. Purchaser must bear any transportation and delivery costs of the Product to the nearest Authorized Service Center or the additional travel expenses of a certified trained technician.

## **Warranty (continued)**

---

### **DISCLAIMER OF WARRANTIES AND LIMITATION OF LIABILITY**

There are no warranties, either express or implied, other than those listed and described above, including but not limited to any implied warranties of merchantability or fitness for a particular purpose, that shall apply after the express warranty period stated above.

No other express warranty or guarantee given by any person, firm, or corporation with respect to this Product shall be binding on Forno.

Forno shall not be liable for any loss of revenue or profits, failure to realize expected savings or other benefits, time away from work, loss of food or beverages, travel or lodging expenses, costs to rent or purchase replacement appliances, or any remodeling or construction expenses.

Forno shall also not be liable for any indirect, incidental, special, or consequential damages arising from the use, misuse, or inability to use this Product, regardless of the legal theory on which the claim is based, and even if Forno has been advised of the possibility of such damages.

In no event shall Forno's total liability exceed the purchase price of the Product giving rise to the claim.

The Purchaser assumes all risk and liability for any loss, damage, or injury to persons or property resulting from the use, misuse, or inability to use the Product, except where such damage is directly caused by the negligence of Forno.

This limited warranty is non-transferable, applies only to the original Purchaser, and constitutes the Purchaser's exclusive remedy.



FOR  
**FAST SUPPORT**  
EMAIL AT [INFO@FORNO.CA](mailto:INFO@FORNO.CA) 

Customer Support: Call 1-866-231-8893 or email: [info@forno.ca](mailto:info@forno.ca)