

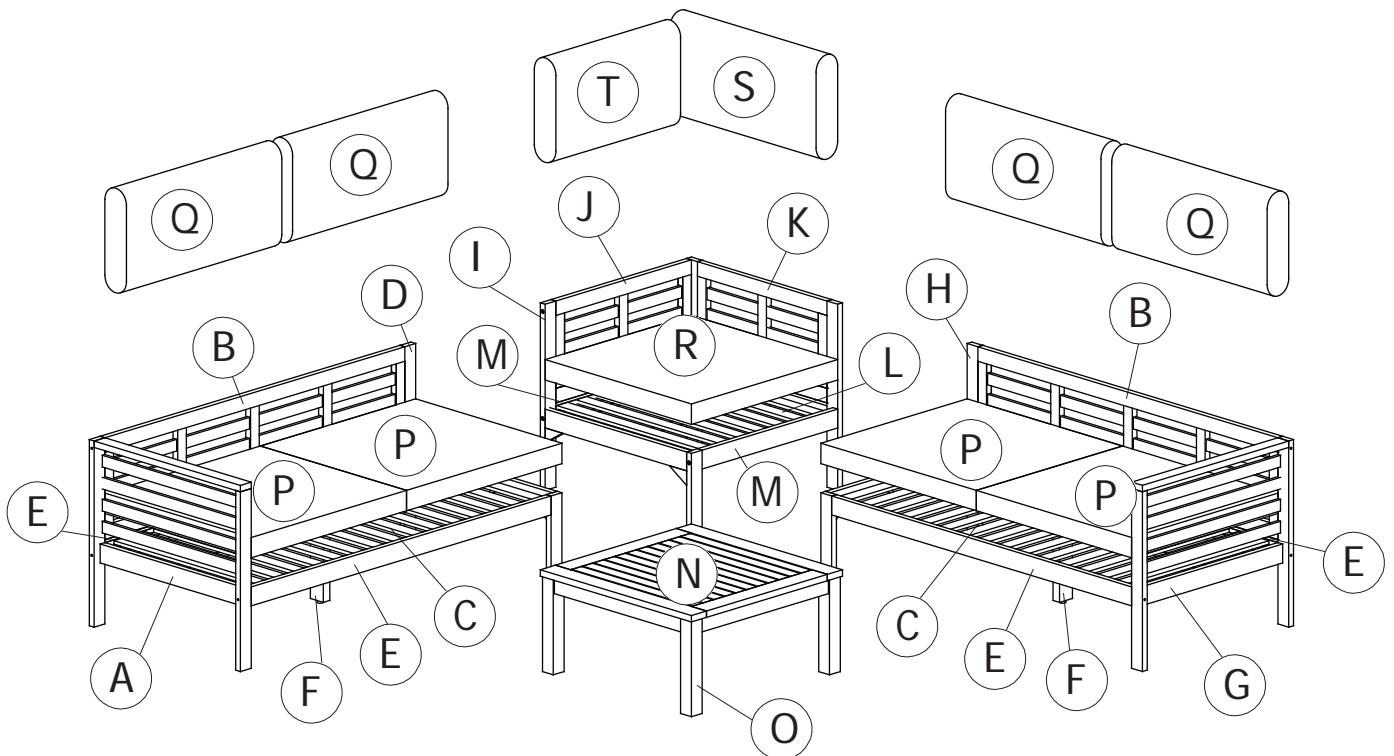

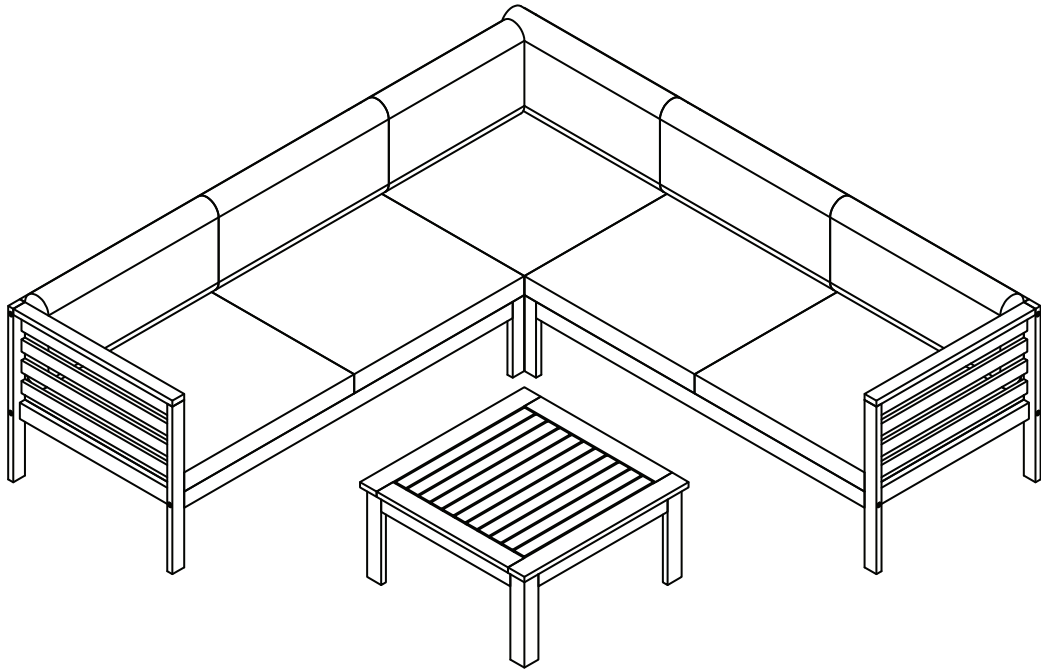

ASSEMBLY INSTRUCTION

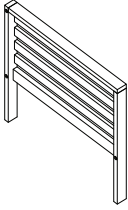
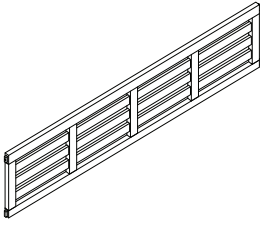
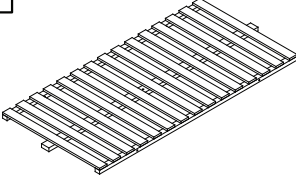
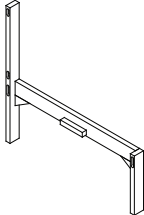
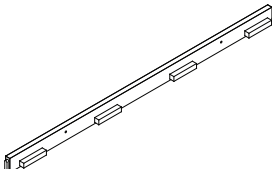

Part List

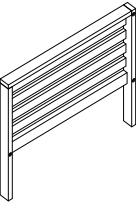
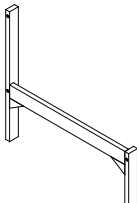
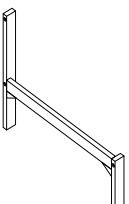
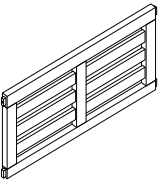
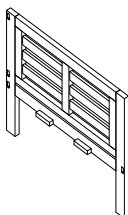
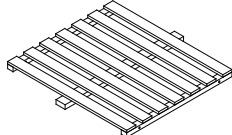
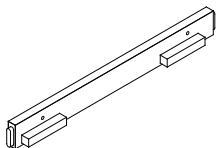
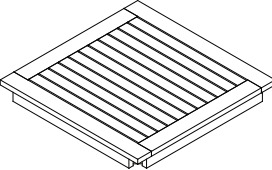
A  (1 pc)	B  (2 pcs)	C  (2 pcs)	D  (1 pc)
E  (4 pcs)	F  (2 pcs)	G  (1 pc)	H  (1 pc)
I  (1 pc)	J  (1 pc)	K  (1 pc)	L  (1 pc)
M  (2 pcs)	N  (1 pc)	O  (4 pcs)	P  (4 pcs)
Q  (4 pcs)	R  (1 pc)	S  (1 pc)	T  (1 pc)

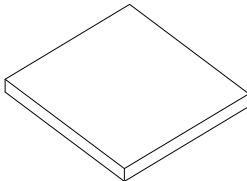
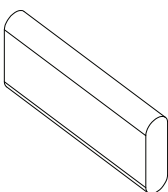
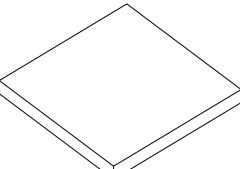
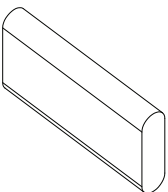
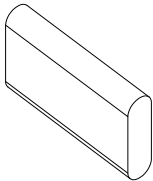
Hardware List

1

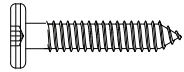

M6x45
(12 pcs)

2

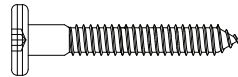

M6x50
(2 pcs)

3

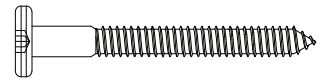

M6x80
(18 pcs)

4



M8x50
(4 pcs)

5

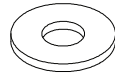

Ø8.5x20
(4 pcs)

6



Ø8.5x20
(4 pcs)

7

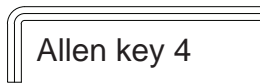

Allen key 4

(4 pcs)

CARTON CONTENT:

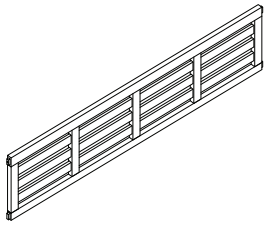

B (2 pcs)

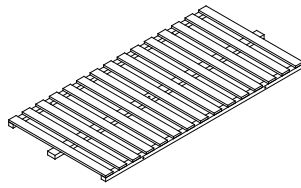

C (2 pcs)

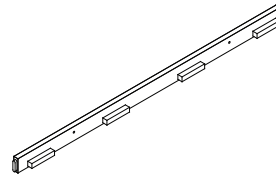

E (4 pcs)



F (2 pcs)

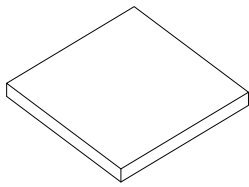

P (4 pcs)

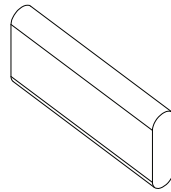

Q (4 pcs)

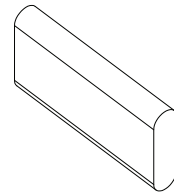

S (1 pc)

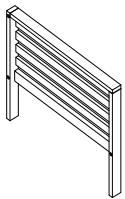

A (1 pc)

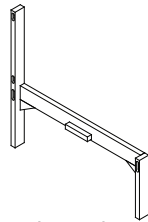

D (1 pc)

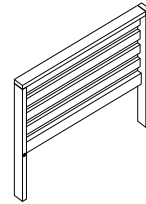

G (1 pc)

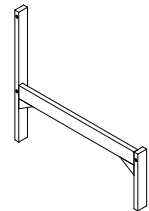

H (1 pc)

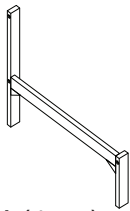

I (1 pc)

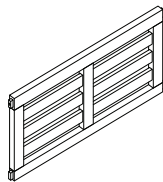

J (1 pc)

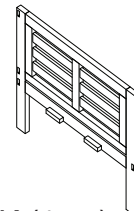

K (1 pc)

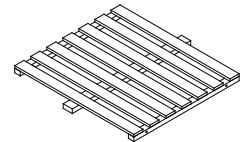

L (1 pc)

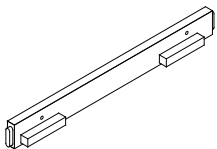

M (2 pcs)

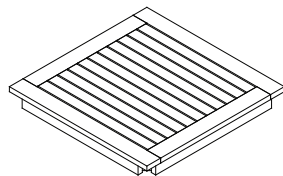

N (1 pc)

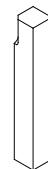

O (4 pcs)

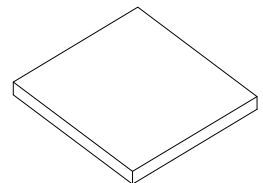

R (1 pc)

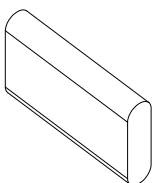

T (1 pc)

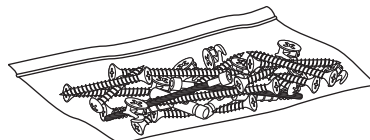

Hardware

STEP1: Following below illustration.

3



6pcs

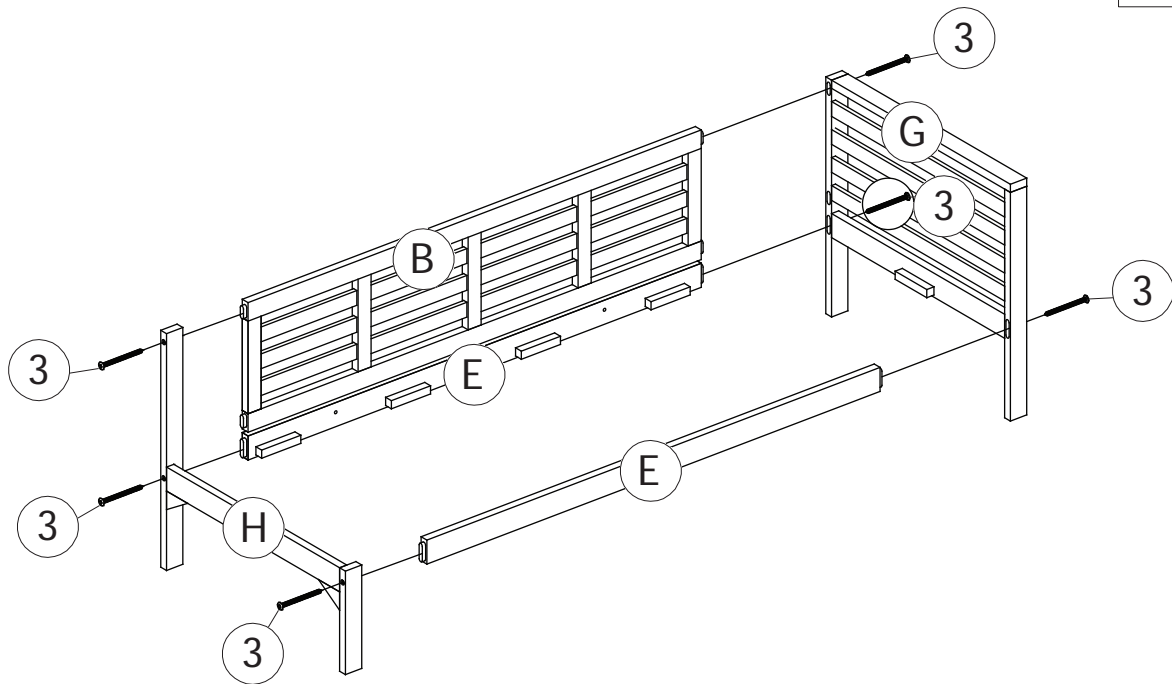

STEP2: Following below illustration.

2



1pc

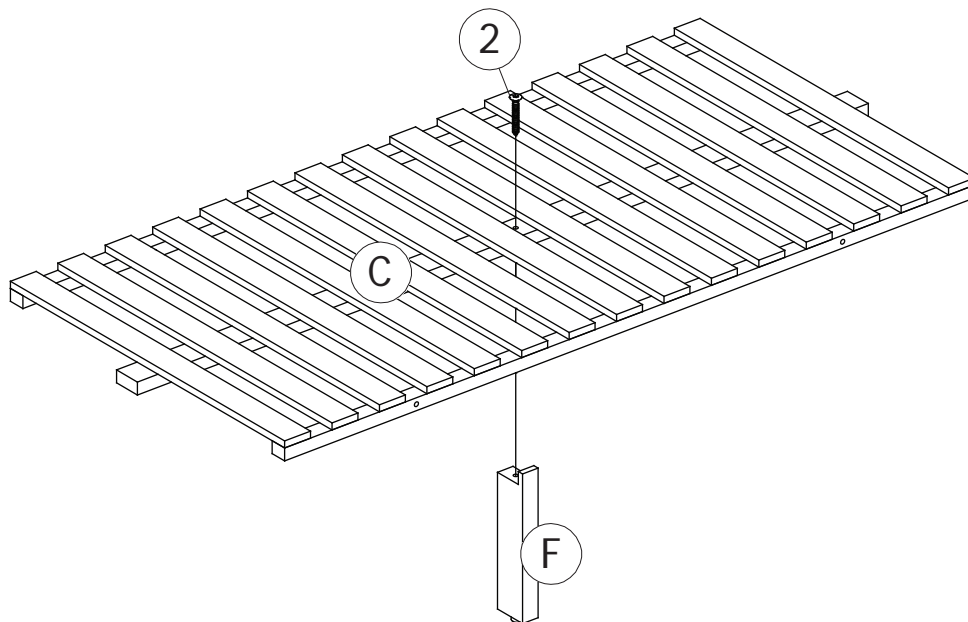

STEP3: Following below illustration.

1



4pcs

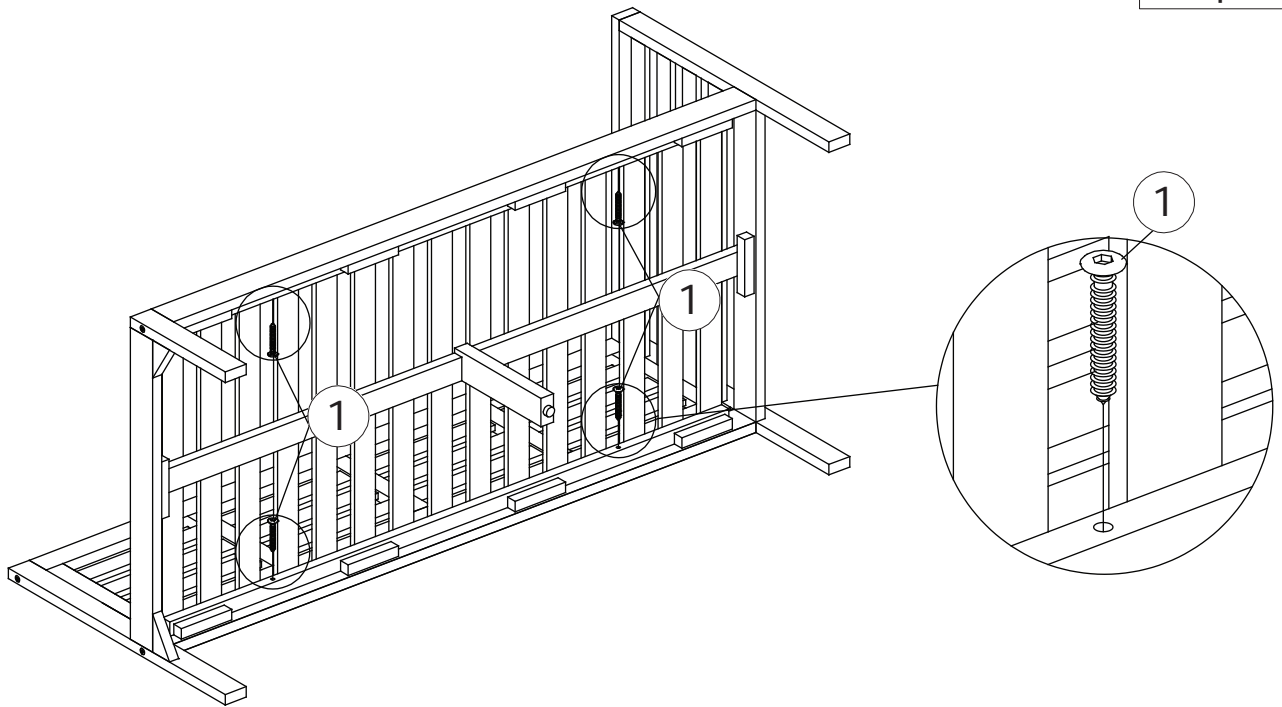

STEP4: Following below illustration.

3



6pcs

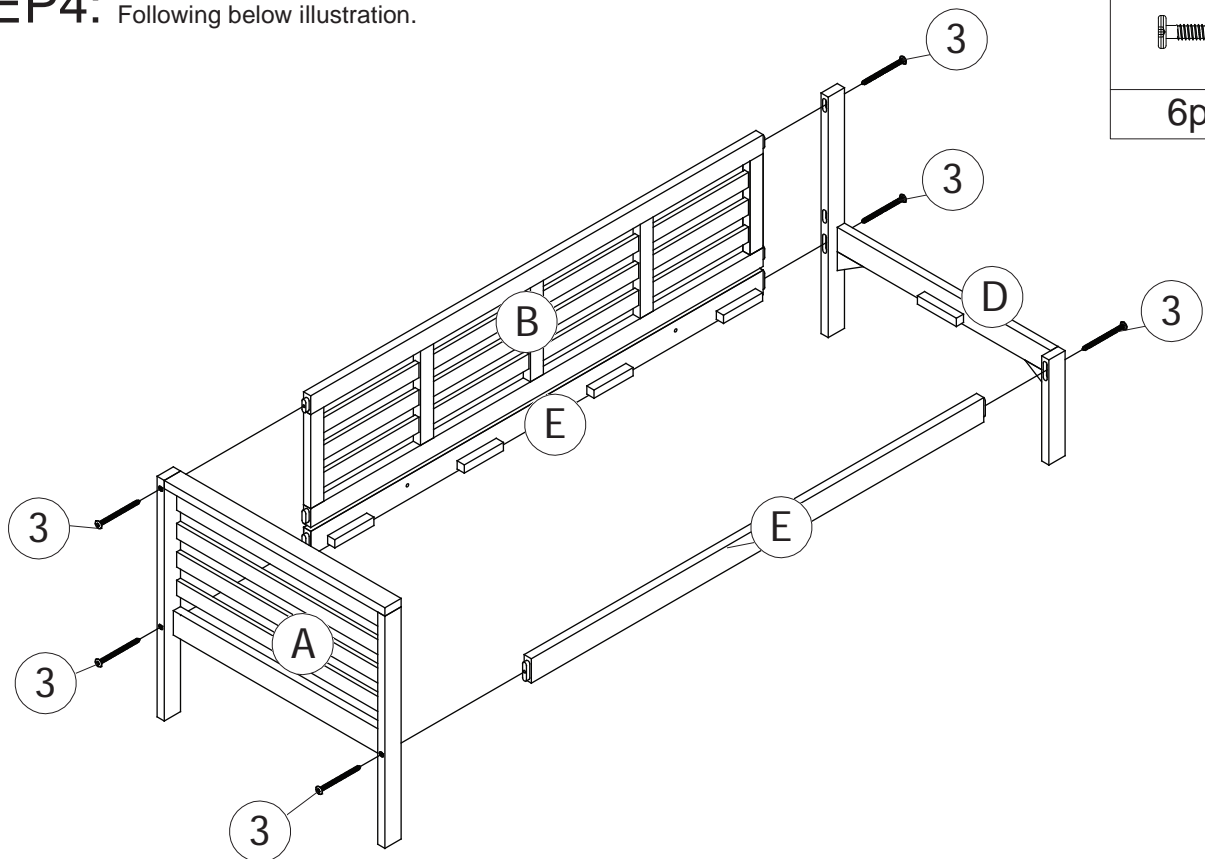

STEP5: Following below illustration.

2



1pc

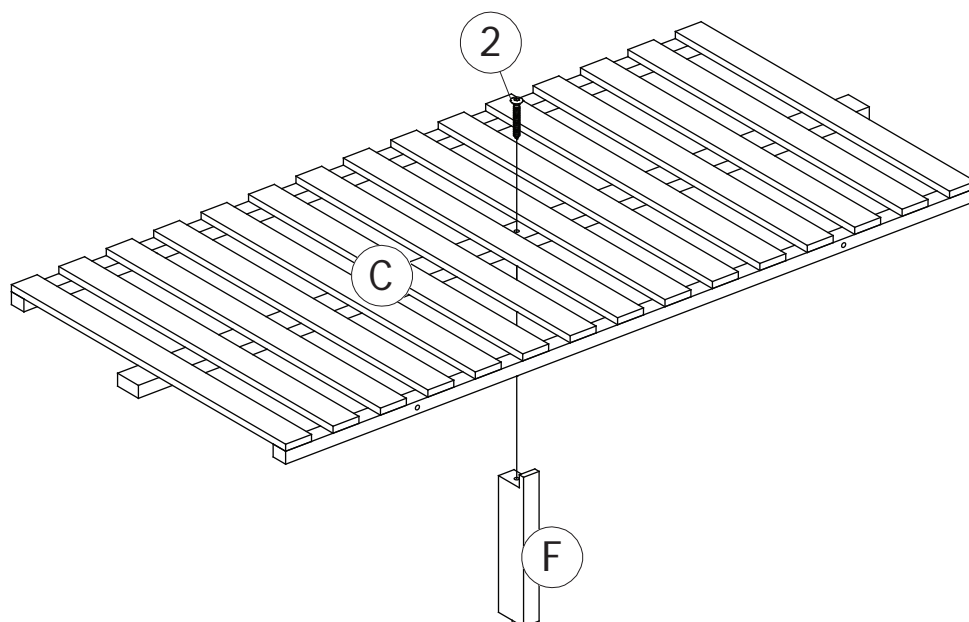

STEP6: Following below illustration.

1



4pcs

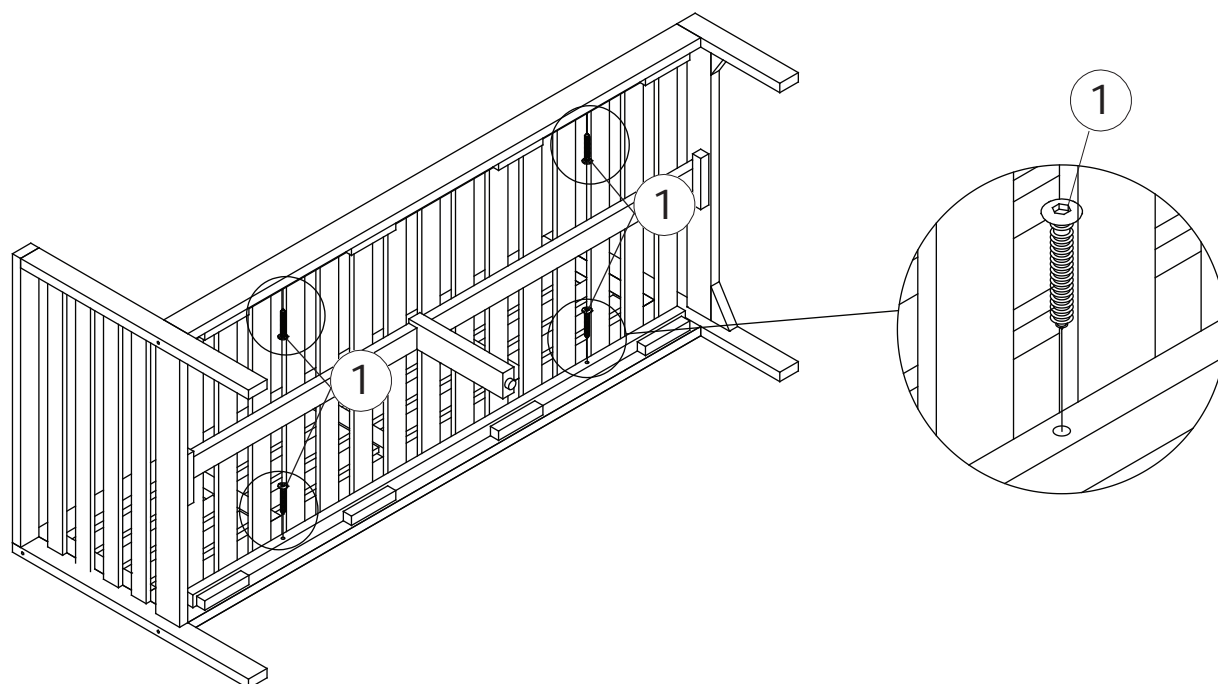

7/10

STEP7: Following below illustration.

3



6pcs

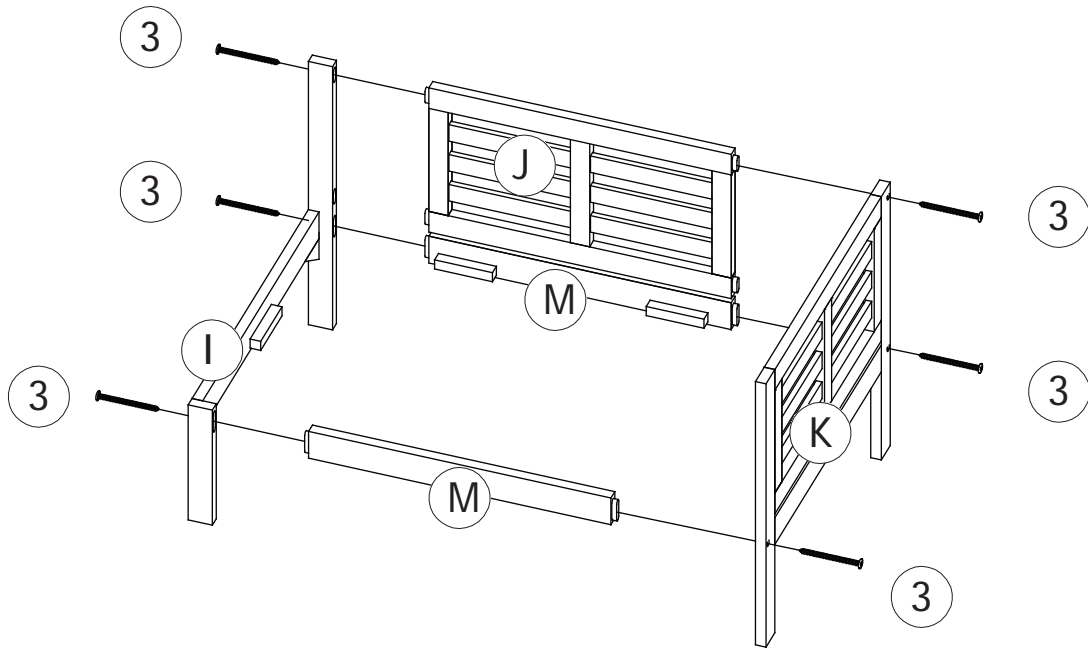

STEP8: Following below illustration.



1

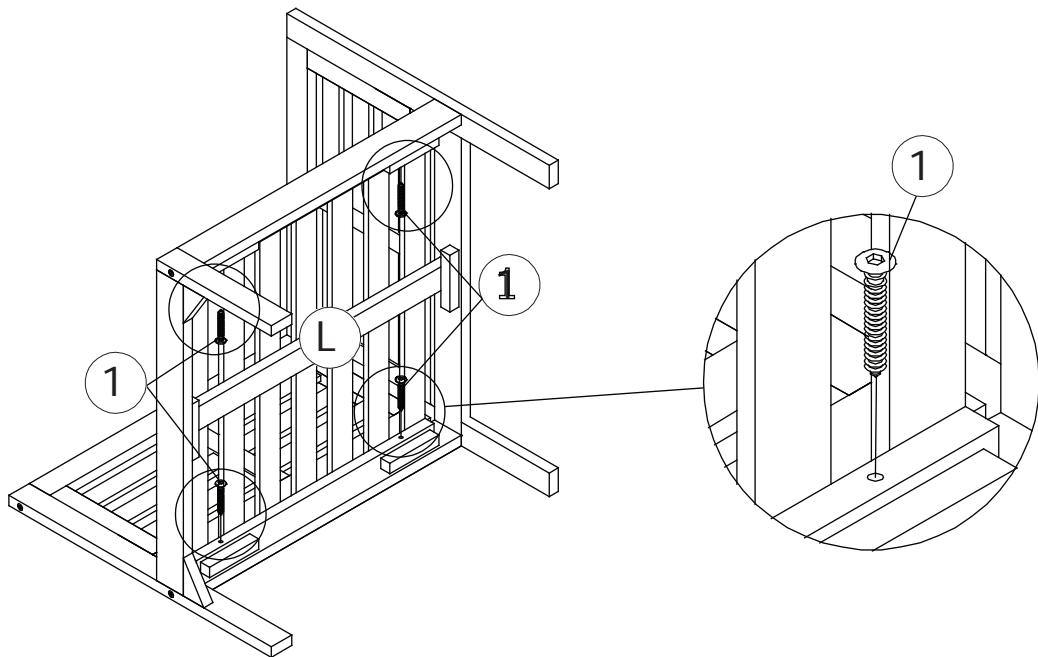

4pcs



STEP9: Following below illustration.

4	
	4pcs
5	
	4pcs
6	
	4pcs

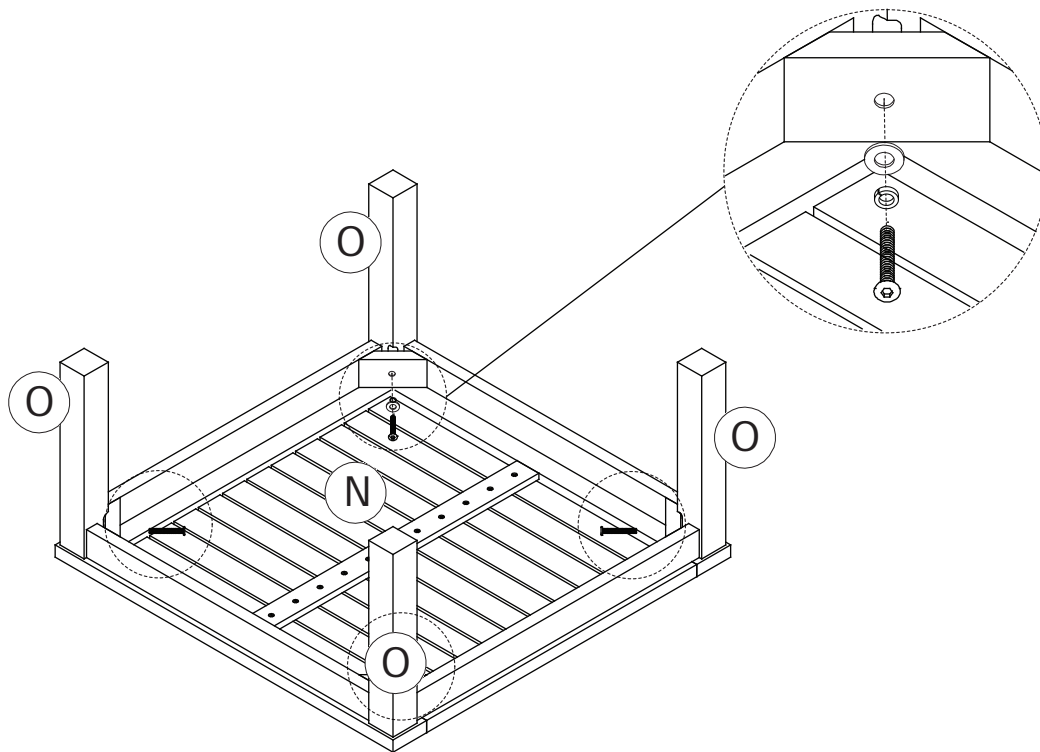

STEP10: Following below illustration.

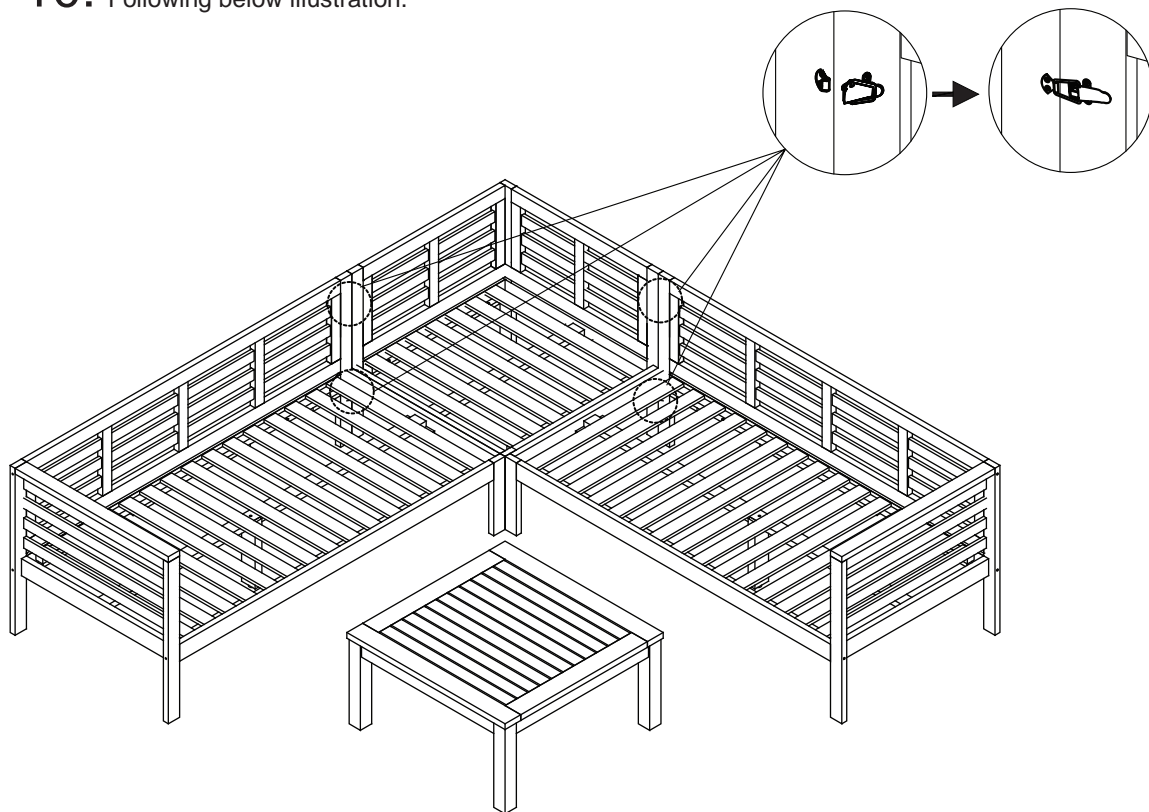

FINISH:

