

Assembly Instructions

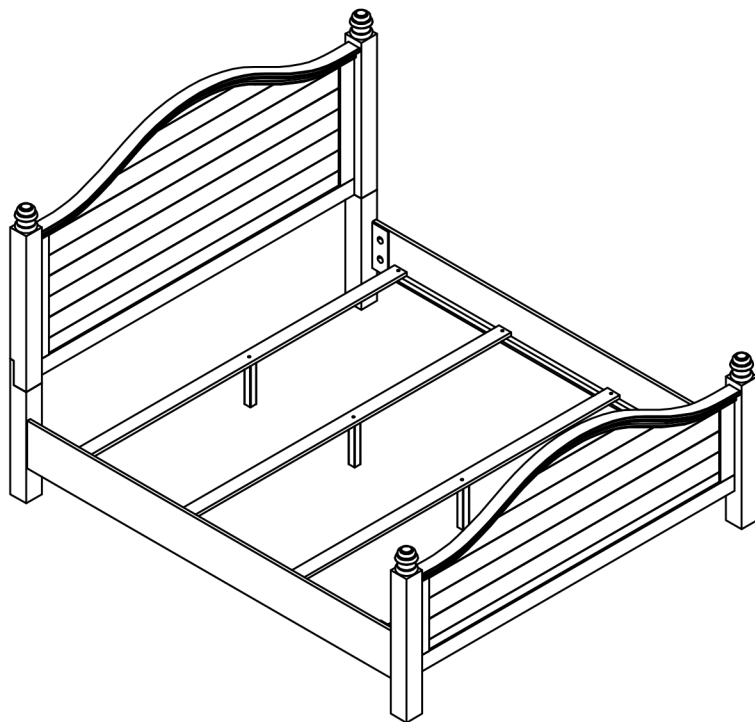

ASSEMBLY RATING

The Assembly Rating is a 5-point system that shows the degree of effort needed in assembling a specific product (with 1 being easy and 5 being difficult). For some products, two persons are recommended.

EASY  DIFFICULT

Tools Required For Assembly:

Allen Wrench

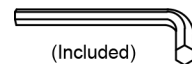

(Included)

Wrench

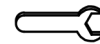

(Included)

Phillips Screwdriver



(Not Included)



2 PERSONS RECOMMENDED

ASSEMBLY & CARE ADVICE

FOR YOUR FURNITURE TO LAST, CORRECT ASSEMBLY AND PROPER MAINTENANCE ARE NECESSARY. PLEASE FOLLOW THE INFORMATION PROVIDED BELOW TO FULLY ENJOY YOUR FURNITURE.

BASIC ASSEMBLY TECHNIQUES

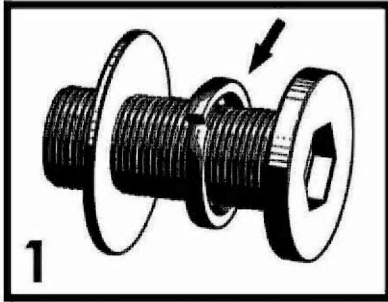

1
When lock or spring washer is used in an assembly, please make sure the lock or spring washer is placed between the larger flat washer and the head of the screw or bolt.

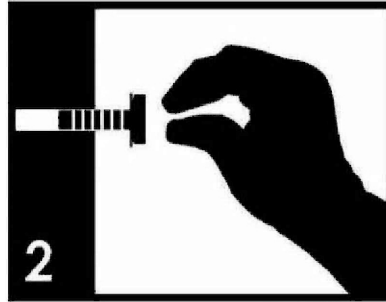

2
Position each part correctly and insert screws or bolts into their respective holes by hand tighten or using the proper hand tool. Only tighten when step is completed or when instructed to do so.

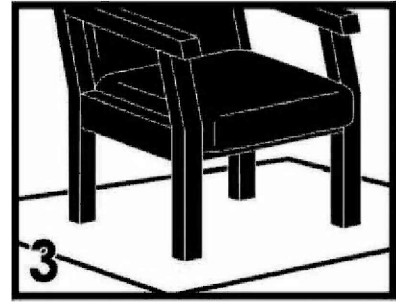

3
Use cardboard or carpet area when assembling furniture to prevent scratches. Make sure the furniture rests on a flat and level surface with each leg evenly touching the floor. No dragging of products/parts.

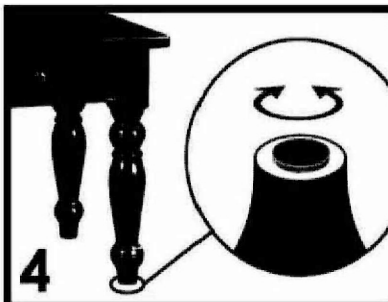

4
Some furniture comes with height adjustment knobs underneath each leg. To lower or to raise each leg, you need to turn clockwise or counterclockwise, respectively.

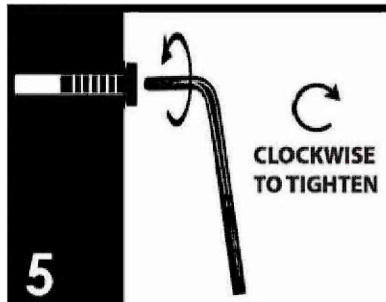

5
Make sure all parts are properly aligned, then use the appropriate hand tool to completely tighten the bolts or screws. Do not use power tools and do not overtighten.

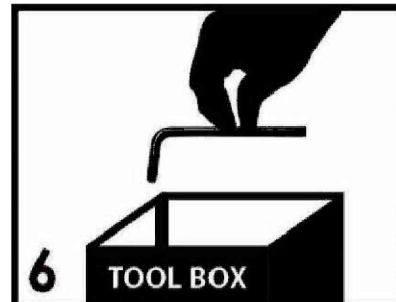

6
Save the instructions and store the Allen wrench or any supplied tool for later maintenance. After two weeks, check and tighten any loose hardware and repeat again every six months thereafter.

IT IS THE USER'S RESPONSIBILITY TO MAINTAIN THE FURNITURE. THE HARDWARE MAY LOOSEN OVER TIME AND MAY CAUSE THE FURNITURE TO BE WOBBLY AND UNABLE TO SUPPORT ITS INTENDED WEIGHT CAPACITY. THIS MAY LEAD TO COLLAPSE AND MAY CAUSE SERIOUS INJURY.



FAILURE TO FOLLOW THE GUIDELINES ABOVE MAY RESULT IN INJURY AND/OR PROPERTY DAMAGE.

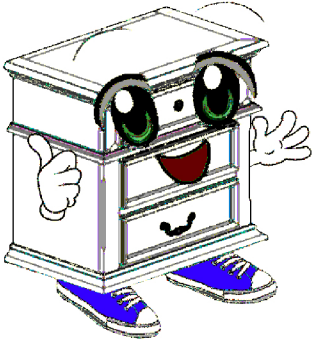







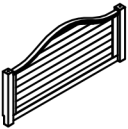
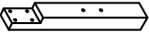
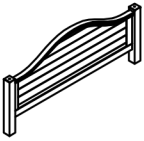

Before you begin, please read Page 2 of "Assembly and Care Advice".

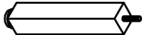
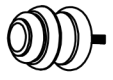
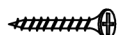
And remember, do not tighten until each step is completed or instructed.

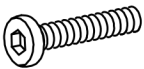
Parts List

Hardware List

	#1 x 1pc Headboard Panel
	#2 x 2pcs Headboard Leg (L&R)
	#3 x 1pc Footboard
	#4 x 2pcs Side Rail
	#5 x 3pcs Slat
	#6 x 3pcs $\Phi 5/16"$ Support Leg 223x35x35mm
	#7 x 4pcs Finial
	#I x 6pcs Screw #8 x 30mm

	#A x 8pcs Bolt $\Phi 5/16"$ x 2"
	#B x 16pcs Lock Washer $\Phi 5/16"$
	#C x 16pcs Flat Washer $\Phi 5/16"$
	#D x 1pc Allen Wrench 4mm
	#E x 8pcs Bolt $\Phi 5/16"$ x 3"
	#F x 8pcs Half Moon Washer $\Phi 5/16"$
	#G x 8pcs Hex Nut $\Phi 5/16"$
	#H x 1pc Wrench 12mm

Exploded View

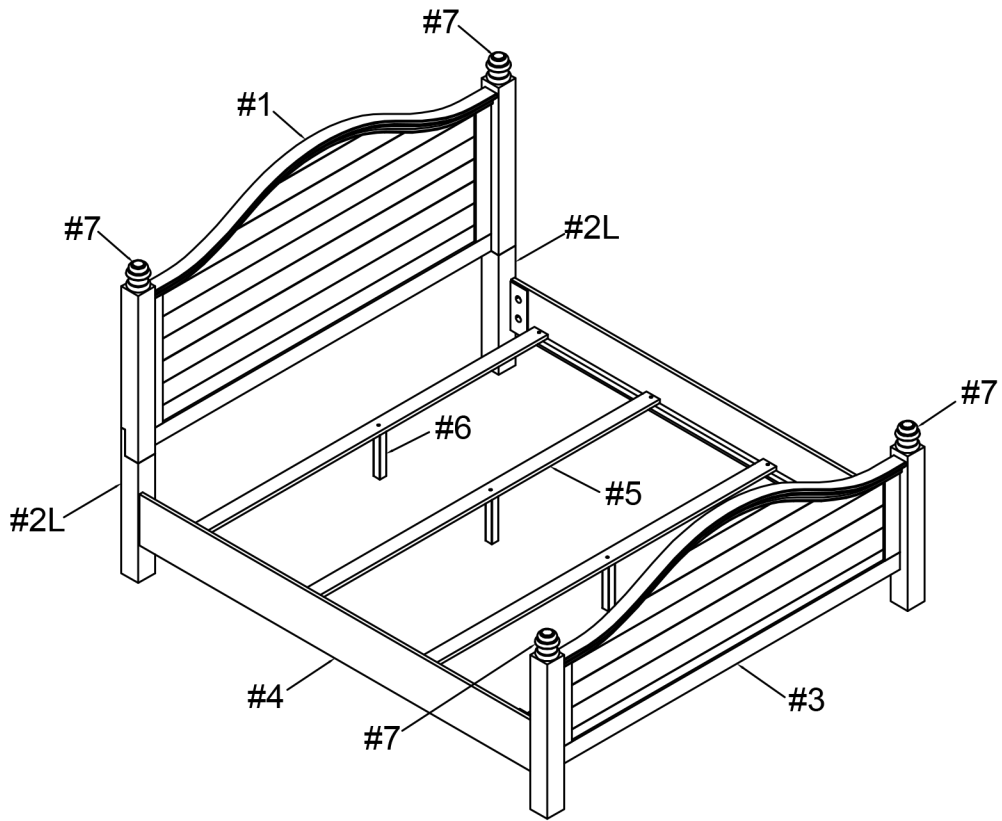

Attach the finials (#7) to the headboard (#1).

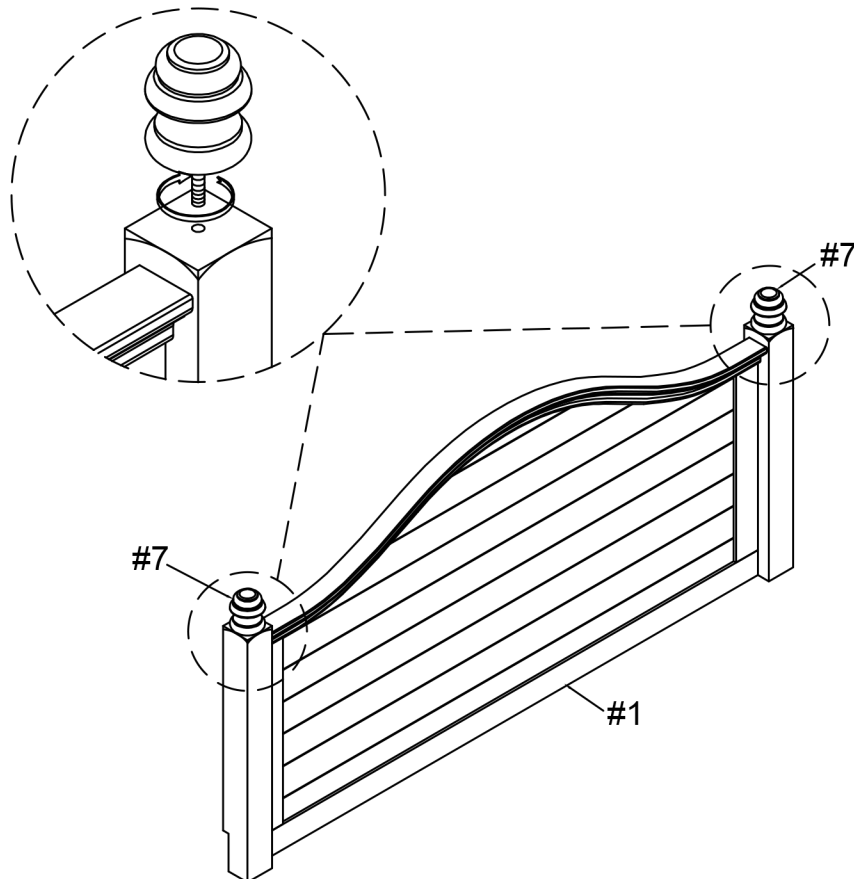



#2

Attach the finials (#7) to the footboard (#3).

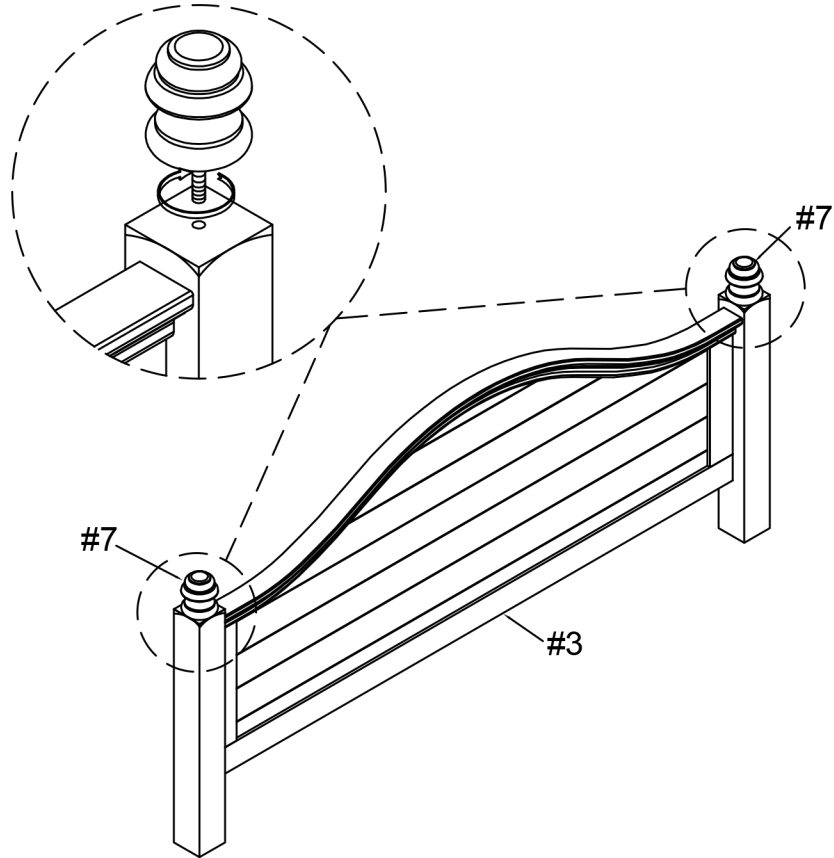

#3

Align HB legs (#2R/L) to the headboard (#1), then secure by using bolts (#A) with washers (#B,C).

- #A x 8pcs
- #B x 8pcs
- #C x 8pcs

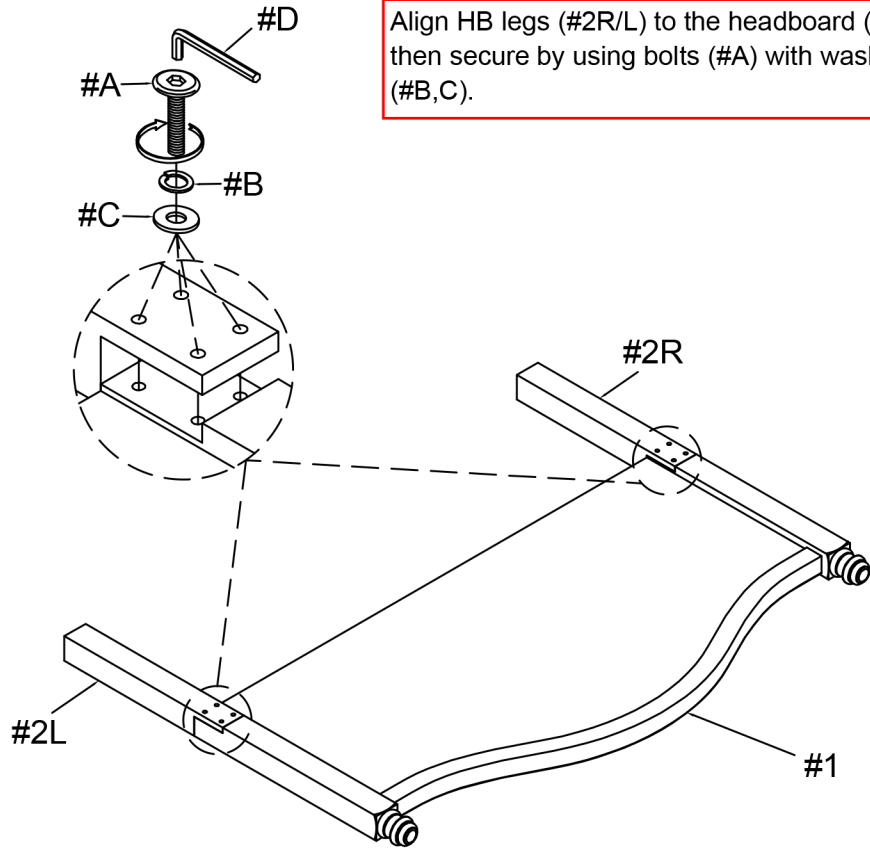



Attach the thread bolts (#E) to the headboard (#1) and footboard (#3), then align the side rails (#4) to the thread bolts (#E). Secure by using half moon washers (#F), lock washers (#B), flat washers (#C) with hex nut (#G).

- #B x 8pcs
- #C x 8pcs
- #E x 8pcs
- #F x 8pcs
- #G x 8pcs

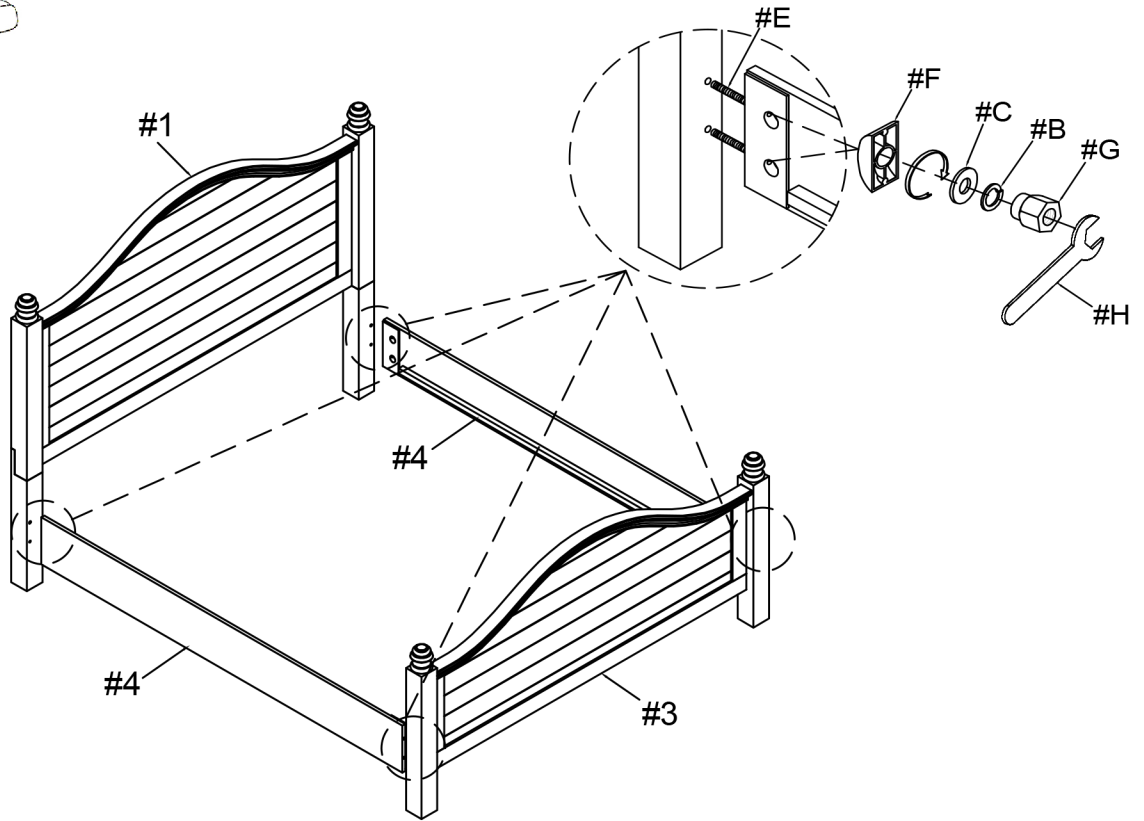

Attach the support legs (#6) to the slats (#5), then adjust the levelers of the support legs (#6) according to ground level.

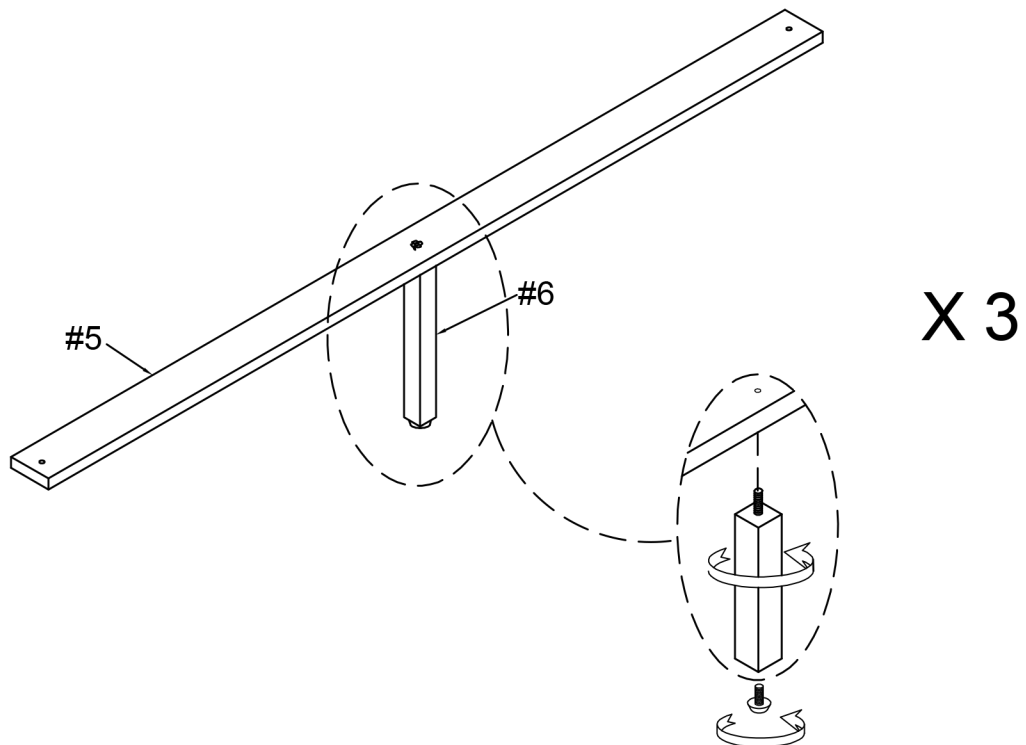



#6

#1 x 6pcs

Align slats (#5) to the side rails (#4) evenly, then secure by using screws (#1).

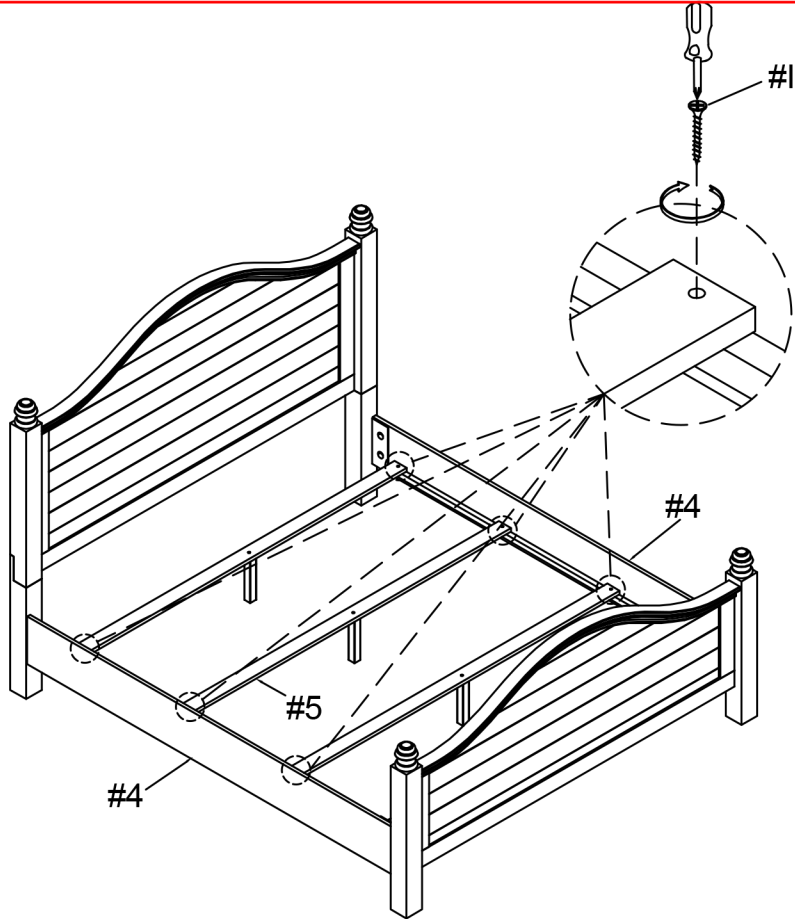

#7

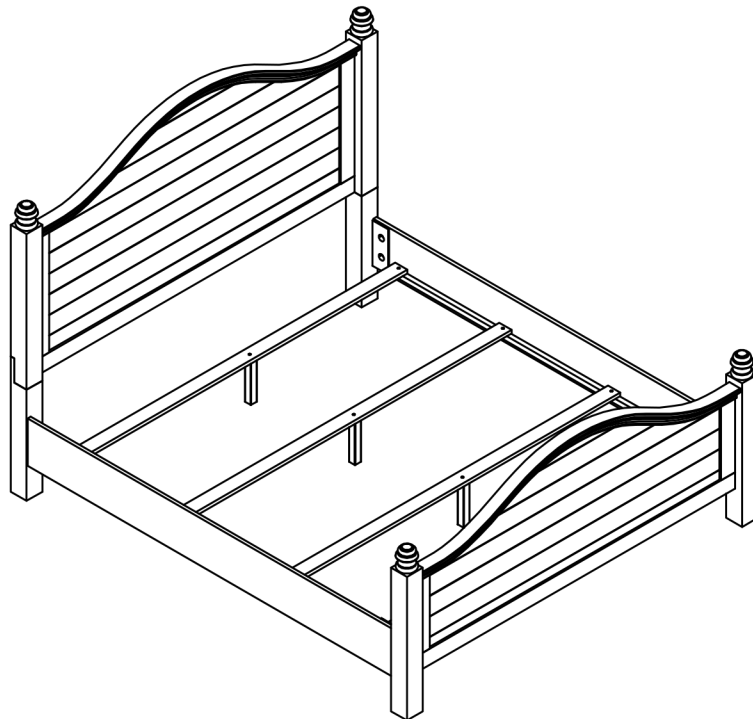

ASSEMBLY IS COMPLETED