

ASSEMBLY INSTRUCTIONS

BUTLER BAR CART

ASSEMBLY
REQUIREMENTS

1 Hours
Assembly Time
(Approximate)

1-Person
Assembly

Tools Required:
(Not Provided)

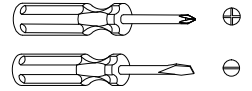

Thank you for purchasing our product!

Please refer and use this assembly instruction to assemble the product. Contact our customer service department in case there are any missing or damage parts or hardware. Replacement parts are normally shipped within 2 or 3 days.

Within 30 days from delivery date

PRODUCTS PURCHASED THROUGH OUR
AUTHORIZED VENDORS ONLY ARE ELIGIBLE
FOR REPLACEMENT PARTS.

We appreciate your business!

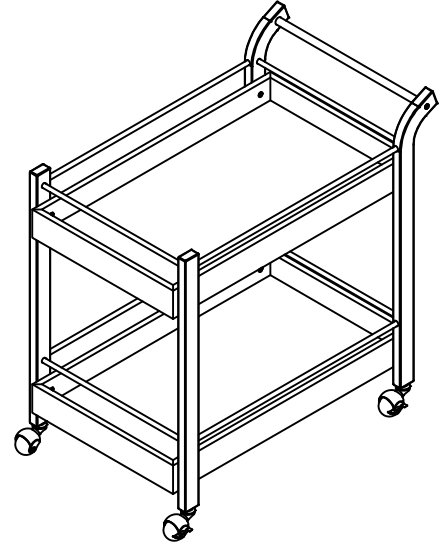

THIS PRODUCT IS FOR INDOOR AND HOUSEHOLD USE ONLY - NOT FOR COMMERCIAL USE.

ASSEMBLY PREPARATION

1. Remove all packaging materials, staples and packing straps from the carton.
2. Refer to Parts List and Hardware List, and ensure parts and hardware are correct before assembly.
Contact customer service for missing parts.
3. Place all wooden parts on a clean, flat and soft surface (e.g. carpet or rug) to prevent scratch and damage to parts.

SAFETY PRECAUTION

1. KEEP ALL HARDWARE PARTS OUT OF REACH OF CHILDREN.
2. DISPOSE PLASTIC PACKAGING MATERIAL IMMEDIATELY TO AVOID ANY RISK OF SUFFOCATION TO CHILDREN AND ANIMALS.

TIPS FOR ASSEMBLY

1. Allow ample room for assembly and assemble the product near where the product will be placed.
2. Assemble the product on a surface that does not scratch or damage the exterior gloss and finish of the furniture.
3. Identify all of the parts, hardware and quantities required for each step.
4. During assembly, do not over-tighten any fittings as this may cause damage.
5. DO NOT USE POWER TOOLS TO ASSEMBLE THIS PRODUCT.
6. Always place the product on a flat, level surface.
7. Do not sit or stand on the partially assembled product; only use the product for which it is intended.

CARE AND MAINTENANCE

- Wipe clean with a soft, dry cloth; avoid the use of harsh chemicals or household cleaners as they may damage the exterior finish of the furniture.
- Hardware may loosen over time. Periodically, check that all connections are tight; re-tighten as necessary.
- Solid wood is impacted by heat and humidity fluctuations which may cause small joint separations or hairline cracks; place the furniture away from direct sunlight and air conditioning vents, heating vents or units to protect the furniture.

ASSEMBLY INSTRUCTIONS
BUTLER BAR CART ITEM# 98400

PARTS LIST

NO.	PART NAME	QTY	NO.	PART NAME	QTY
(A)	Top Tray	1	(D)	Front Right Column	1
(B)	Bottom Tray	1	(E)	Rear Left Column	1
(C)	Front Left Column	1	(F)	Rear Right Column	1



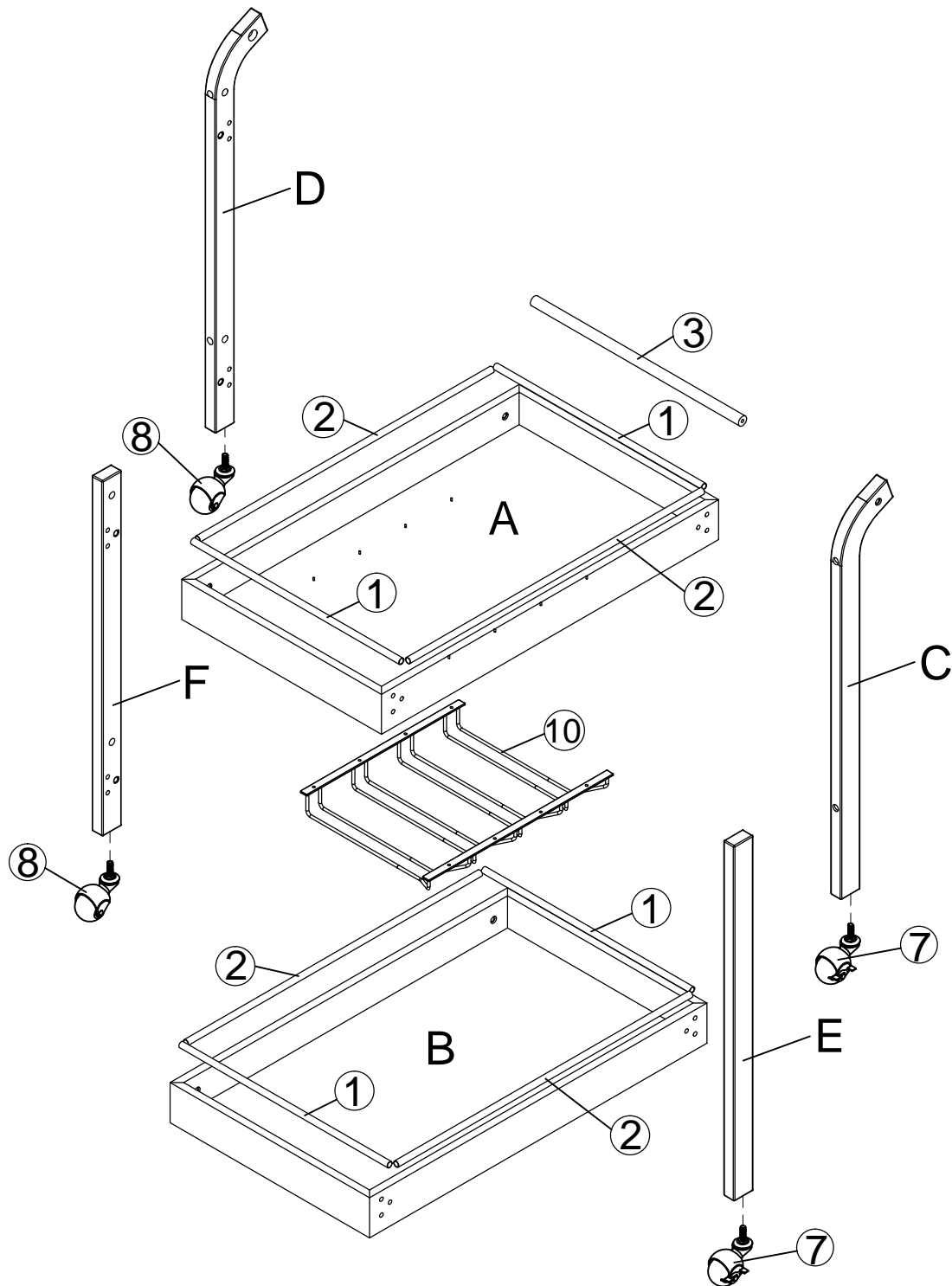



ASSEMBLY OVERVIEW

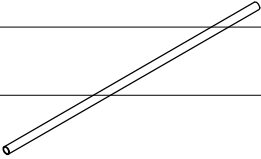
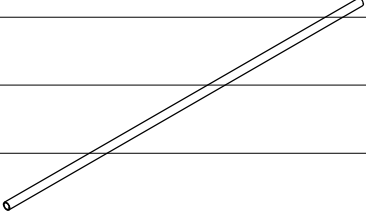
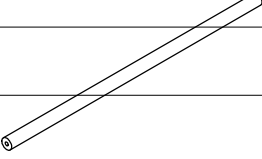
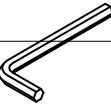
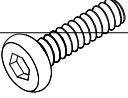
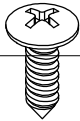

ASSEMBLY INSTRUCTIONS

BUTLER BAR CART

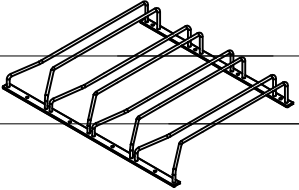
HARDWARE LIST

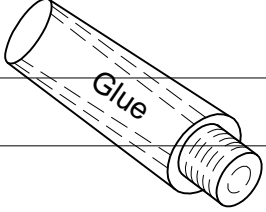
4CM 3CM 2CM 1CM 0CM				
	4X $\phi 12 \times 485 \text{mm}$ 1 Iron Tray Support	4X $\phi 12 \times 685 \text{mm}$ 2 Iron Stretcher	1X $\phi 19 \times 485 \text{mm}$ 3 Handle Bar	1X 4mm 4 Allen Key
2CM 1CM 0CM				
	10X $\phi 1/4 \times 25 \text{mm}$ 5 Screw	8X $\phi 3.5 \times 15 \text{mm}$ 6 Screw	2X $\phi 5/16 \times 2 \text{''}$ 7 Caster with Lock	2X $\phi 5/16 \times 2 \text{''}$ 8 Caster
3CM 2CM 1CM 0CM				
	1X 9 Wrench	1X $430 \times 330 \times 52 \text{mm}$ 10 Wine Rack	16X $\phi 8 \times 30 \text{mm}$ 11 Wood Dowel	1X 12 Glue

EXTRA HARDWARE

 $\phi 1/4 \times 25 \text{mm}$
 2PCS
 Screw

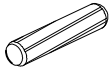

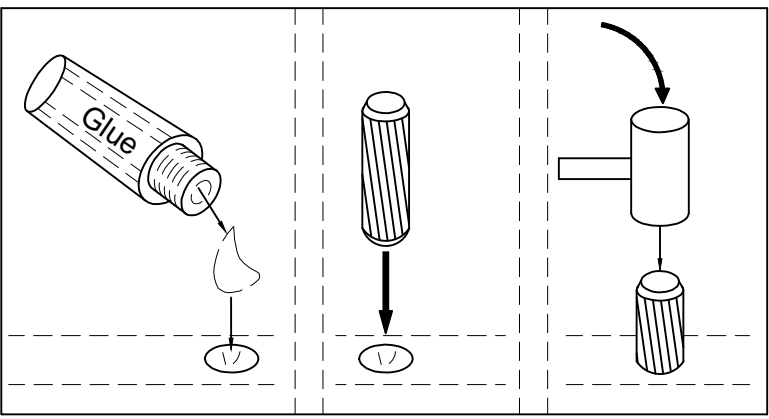
 $\phi 8 \times 30 \text{mm}$
 2PCS
 Wood Dowel



ASSEMBLY INSTRUCTIONS

BUTLER BAR CART

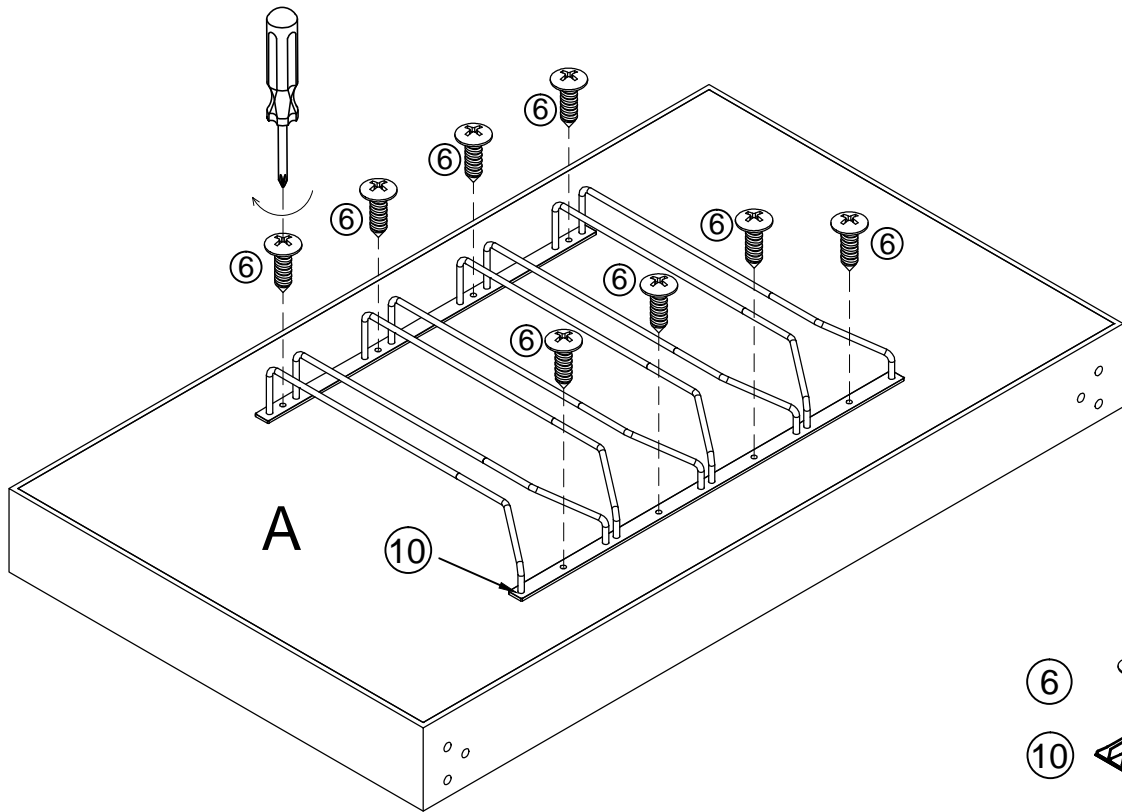
STEP 1



Place Top Tray (A) bottom side up as shown and position Wire Rack (10) to align the screw holes on each part. Use Screw (C) to fasten (10) to (A). Do not tighten (6) completely until all of the screws are in place.

STEP 2

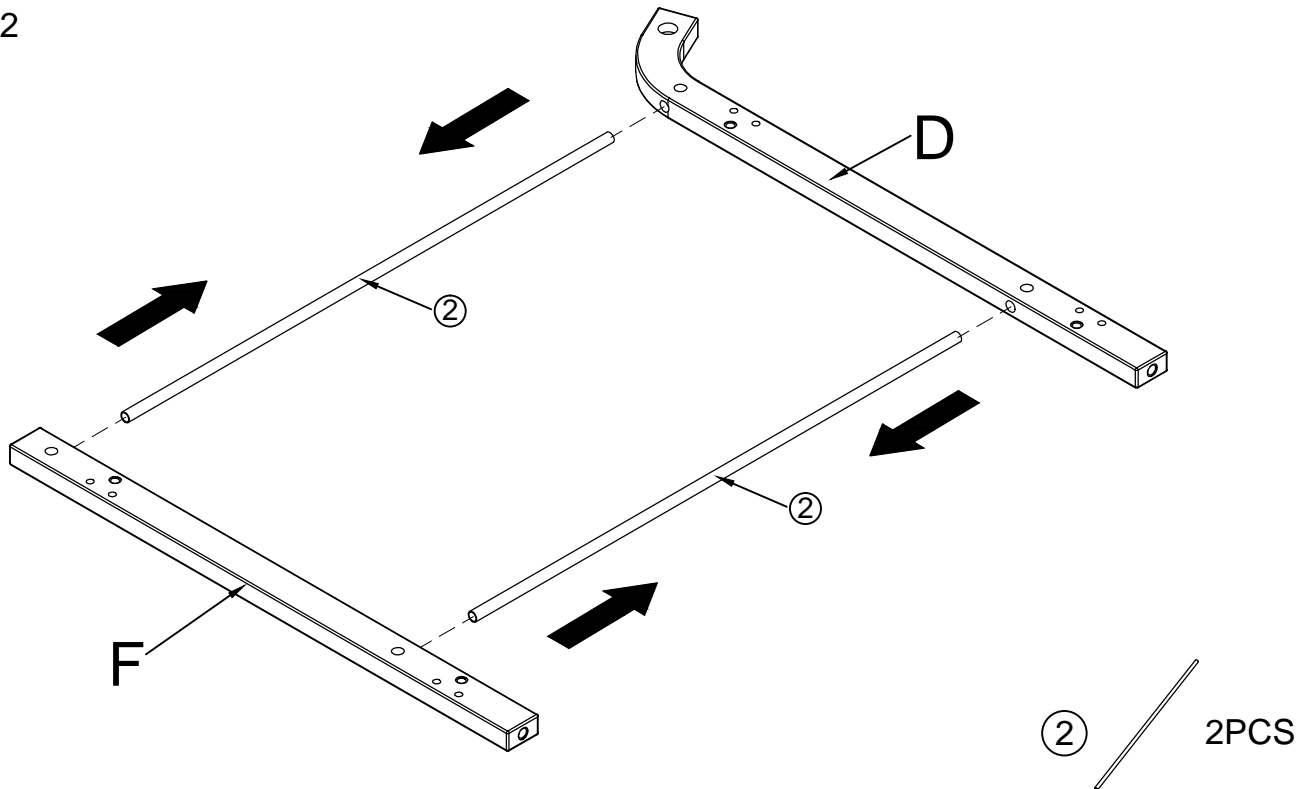

Attach Iron Stretcher (2) to Front Right Column (D) and Rear Right Column (F).

ASSEMBLY INSTRUCTIONS BUTLER BAR CART

STEP 3

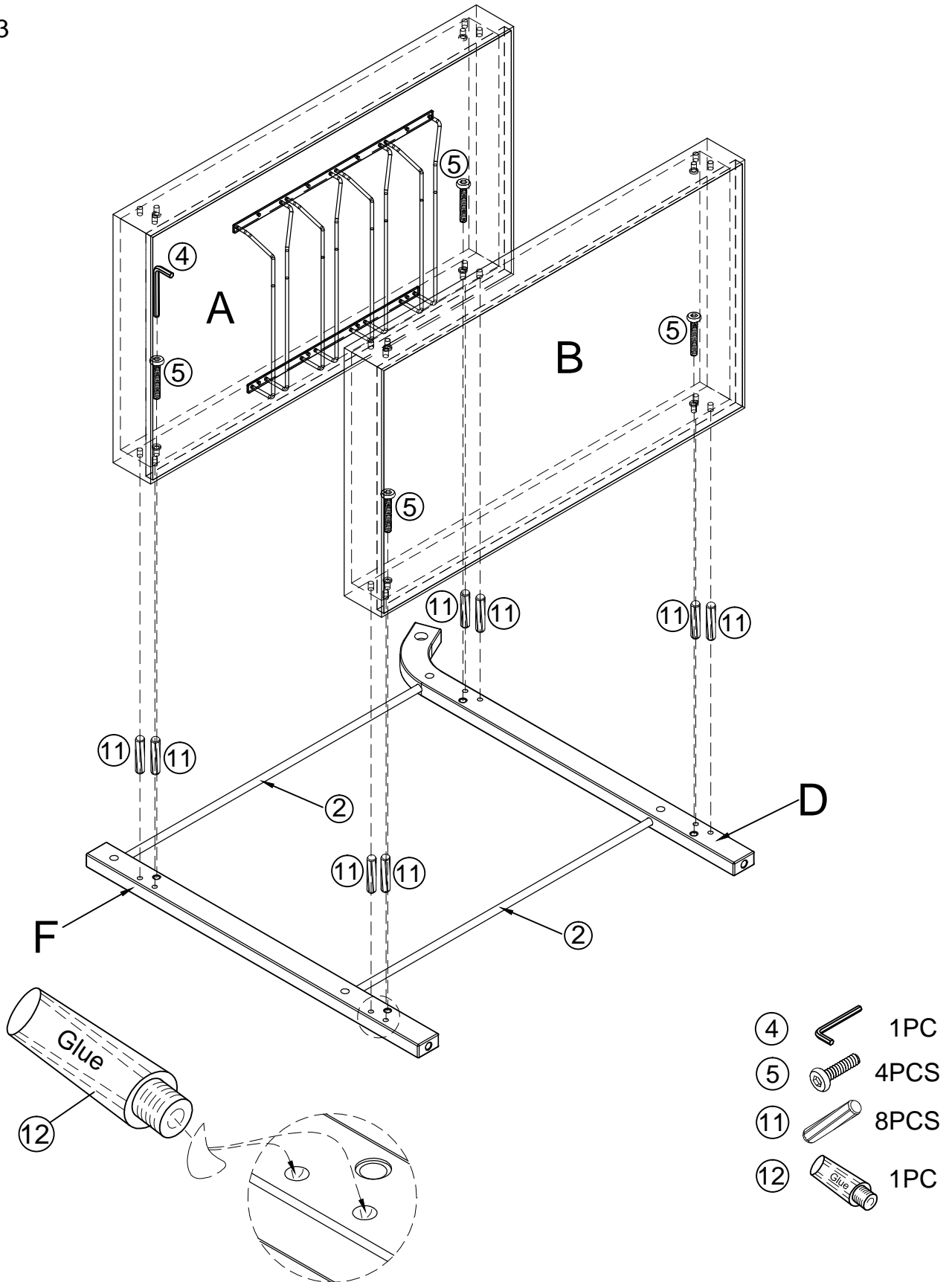

A. After drops glue, Insert Wood Dowel (11) into the designated holes on Front Right Column (D) and Rear Right Column (F).
 B. Attach Bottom Tray (B) to (D & F) via Wood Dowel s shown and use Screw (5) to fasten (B) to (D & F).
 C. Attach To Tray (A) from STEP 1 to (D & F) via Wood Dowel as shown and use Screw (5) to fasten (B) to (D & F).

ASSEMBLY INSTRUCTIONS BUTLER BAR CART ITEM# 98400

STEP 4

- A. Insert Iron Tray Support (1) into the designated holes on Front Right Column (D) and Rear Right Column (F).
- B. After drops glue, Insert Wood Dowel (11) into the designated holes towards the rear on the side panel of Top and Bottom Tray (A & B) as shown.
- C. Attach Rear Left Column (E) to (1) and (A & B) via Wood Dowel and use Screw (5) to fasten (E) to (A & B).
- D. Set assembly aside.

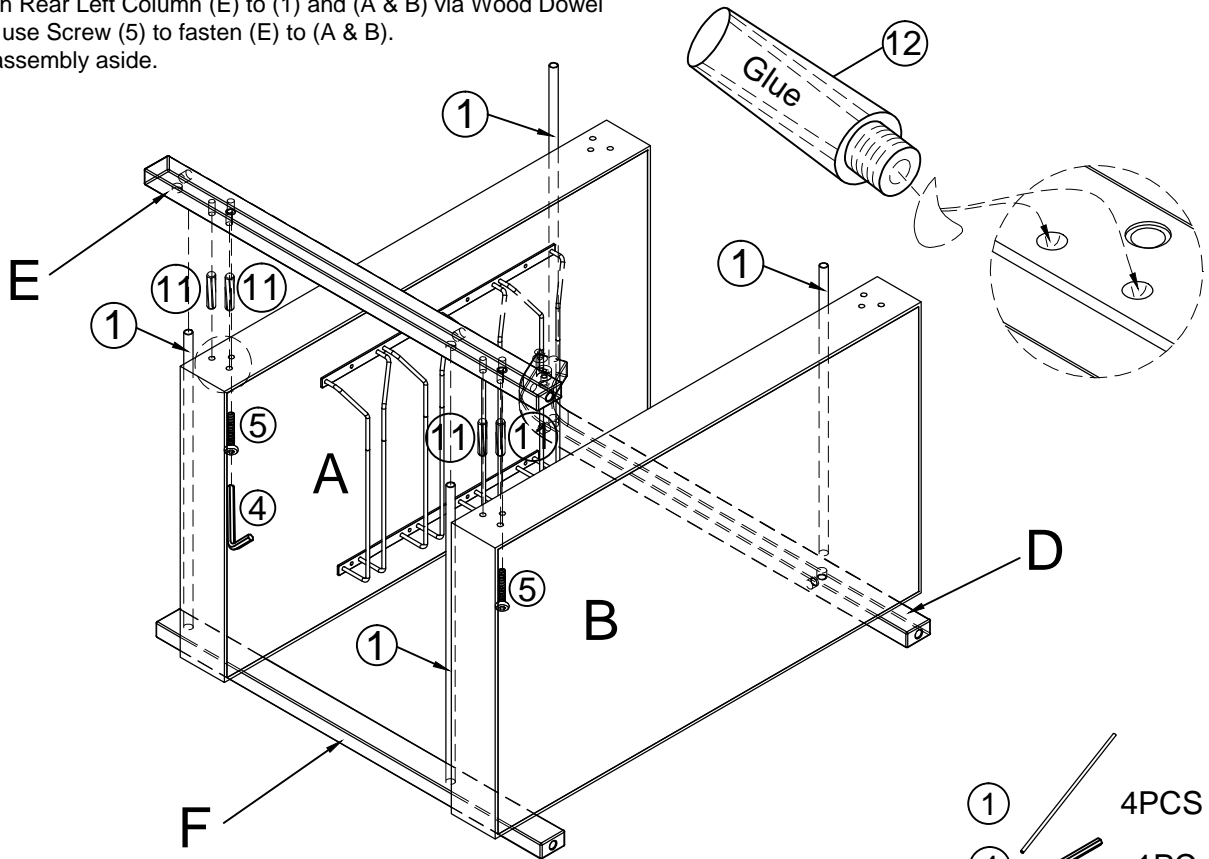

- ① 4PCS
- ④ 1PC
- ⑤ 2PCS
- ⑪ 4PCS
- ⑫ 1PC

STEP 5

- A. Use Screw (5) to fasten Handle Bar (3) to Front Left Column (C). Use Allen key (4) to drive and tighten (5).
- B. Attach remaining Iron Stretcher (2) to (C).

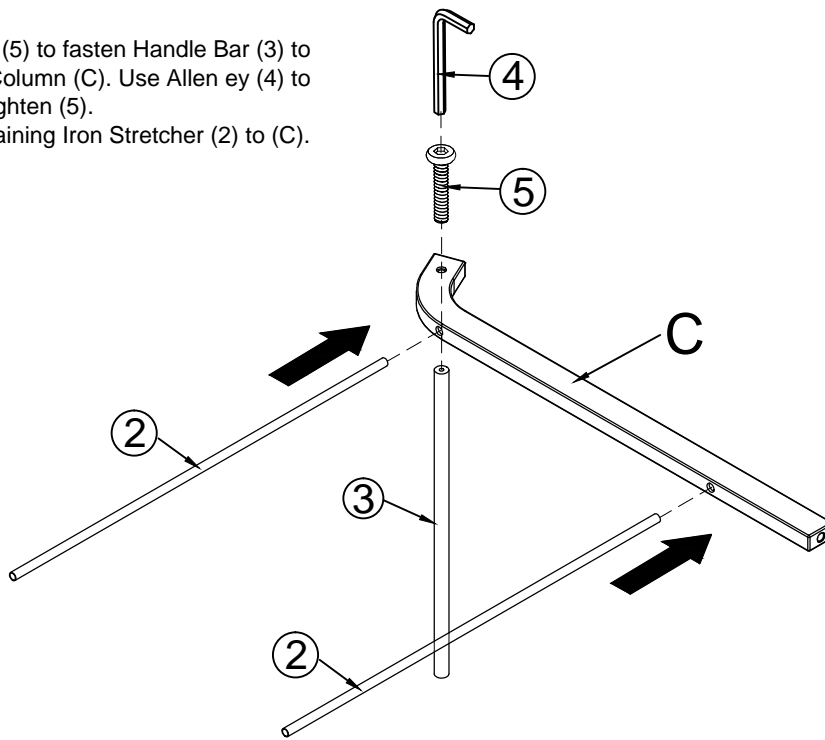





- ② 2PCS
- ③ 1PC
- ④ 1PC
- ⑤ 1PC

ASSEMBLY INSTRUCTIONS BUTLER BAR CART

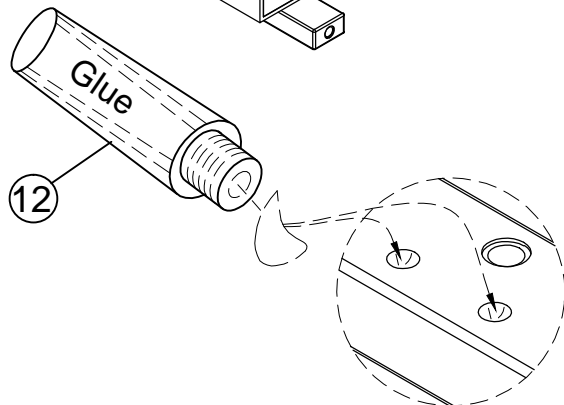
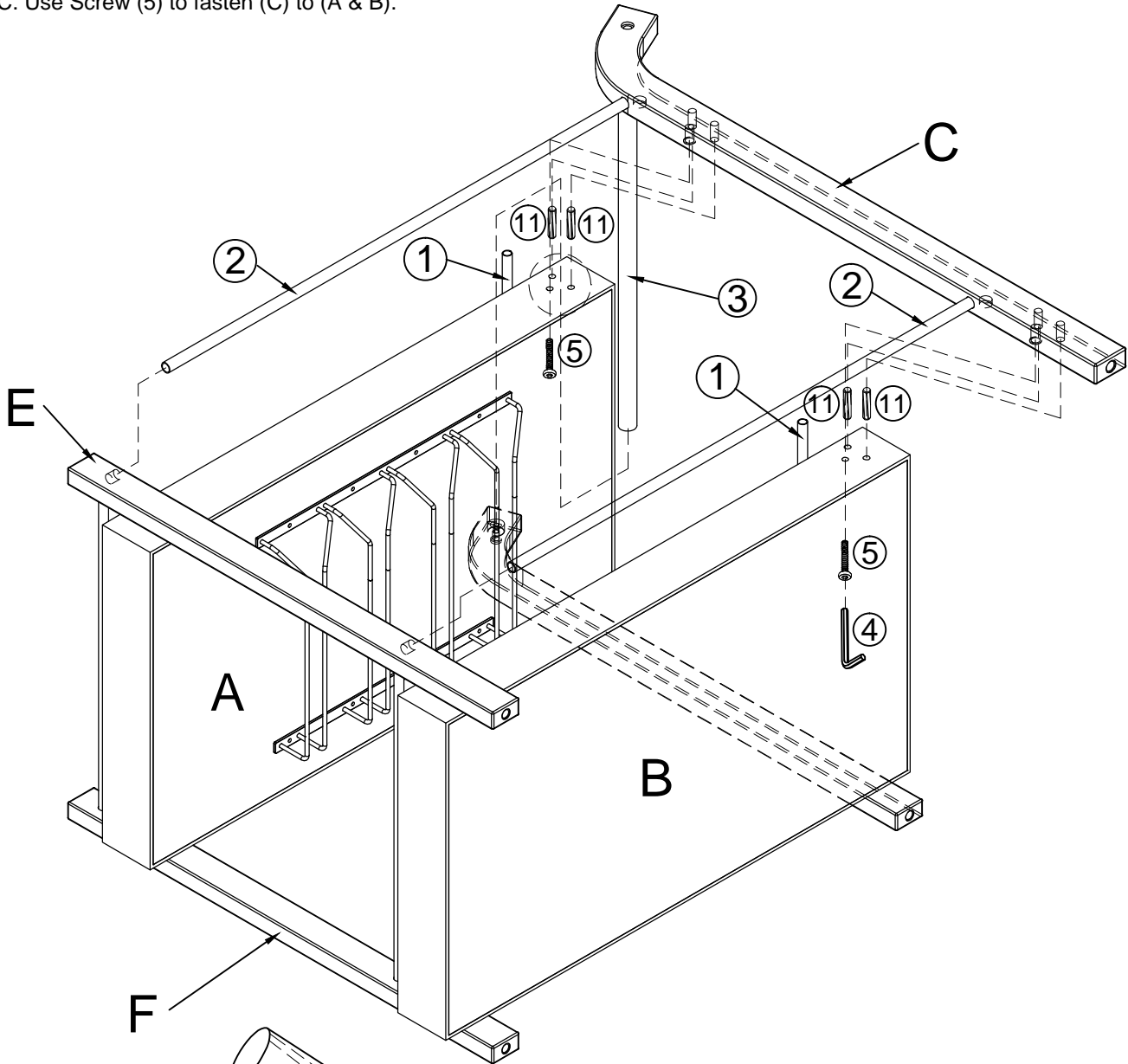
STEP 6

- A. On the assembly in STEP 4, After drops glue, insert Wood Dowel (11) into the designated holes towards the front on the side panel of Top and Bottom Tray (A & B).
- B. Attach the assembly from STEP 5 to the assembly in STEP 4:
1. Fit and attach Stretcher (2) on Column (C) to Column (E).
 2. Attach (C) to Side Panel of (A & B) via Wood Dowel and to Tray Support (1).
 3. Fit and attach Handle Bar (3) to Front Right Column (D).
- C. Use Screw (5) to fasten (C) to (A & B).



- | | | |
|---|---|------|
| ④ |  | 1PC |
| ⑤ |  | 2PCS |
| ⑪ |  | 4PCS |
| ⑫ |  | 1PC |

ASSEMBLY INSTRUCTIONS

BUTLER BAR CART

STEP 7

- A. Fit Castor with Lock (7) to the Column (C & E) and Castor (8) to Column (D & F).
- B. Use Wrench (9) to fasten and tighten (7 & 8) to the respective column.
- C. With assistance, set the assembly right-side up.

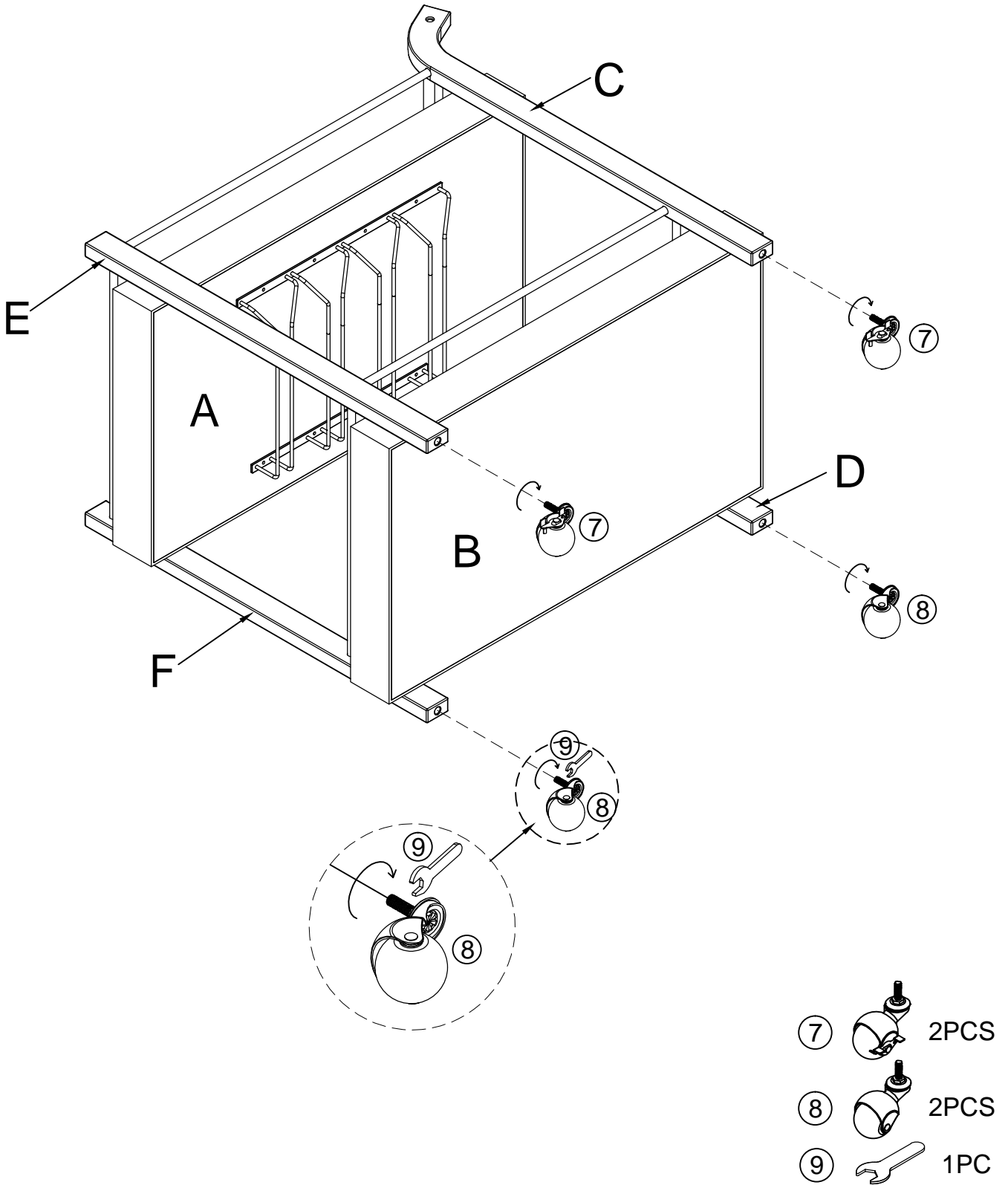

ASSEMBLY INSTRUCTIONS

BUTLER BAR CART

STEP 8

Use Screw (5) to fasten (3) to Front Right Column (D). Use Allen Key (4) to drive and tighten (5).

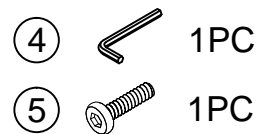
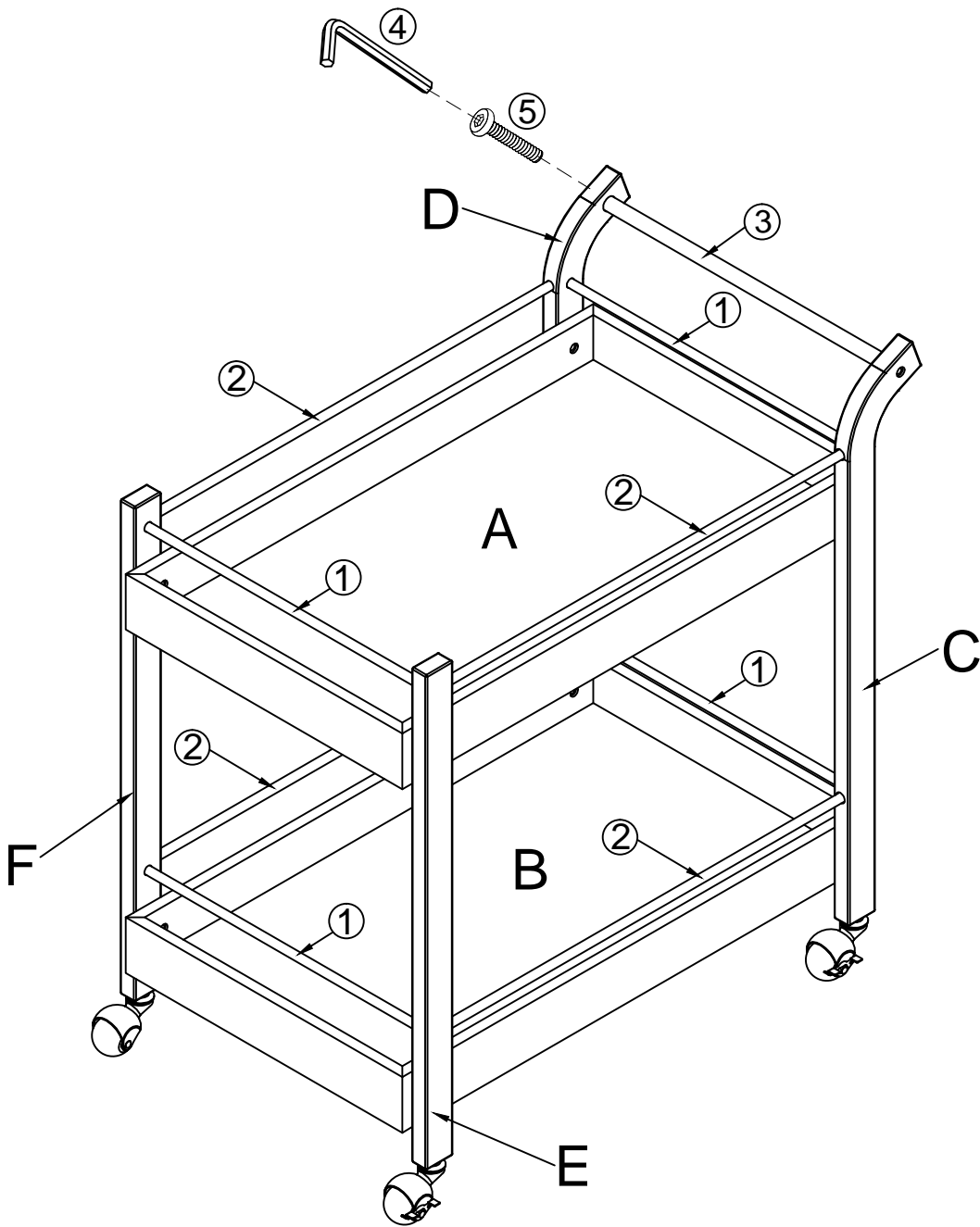

The assembly of the buffet unit is complete.