

30 LAYER COOLING CART FOR 60-CUD

ASSEMBLY GUIDE



PARTS LIST

Thank you for choosing Commercial Dehydrators 30 Layer Cooling Cart for 60-CUD. Please ensure you read the following steps carefully to ensure your item is correctly assembled. Before you begin, carefully unpack, remove and sort the parts as seen below.

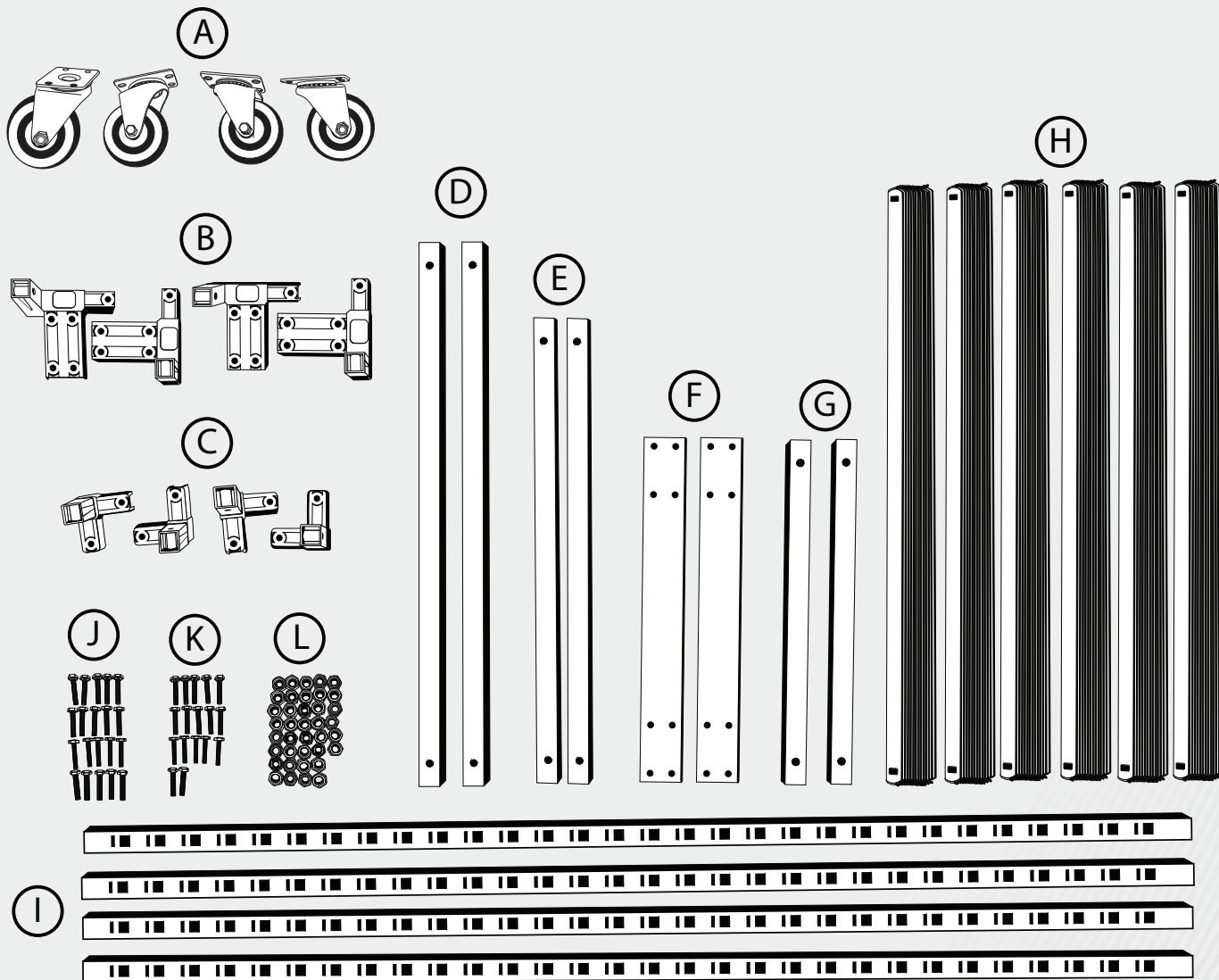

Part	Name	Qty	Dimensions (L x W x D)
A	Wheels	4	100 mm diameter
B	Base Connectors	4	138 x 130 x 81 mm
C	Top Connectors	4	80 x 80 x 25 mm
D	Top Length Supports	2	748 x 30 x 30 mm
E	Base Length Supports	2	630 x 30 x 30 mm
F	Base Width Supports	2	404 x 60 x 30 mm
G	Top Width Supports	2	440 x 30 x 30 mm
H	Shelves	6 packs of 10	830 x 23 x 23 mm
I	Vertical Supports	4	1552 x 30 x 30 mm
J	Frame Bolts	19	490 mm x 14 x 14 mm
K	Base Bolts	18	500 mm x 14 x 14 mm
L	Nuts	31	13 x 13 x 7 mm

ASSEMBLY STEPS

THE BASE

- 1 Connect the Base Connectors (B) to the Base Length Supports (E) as seen below.

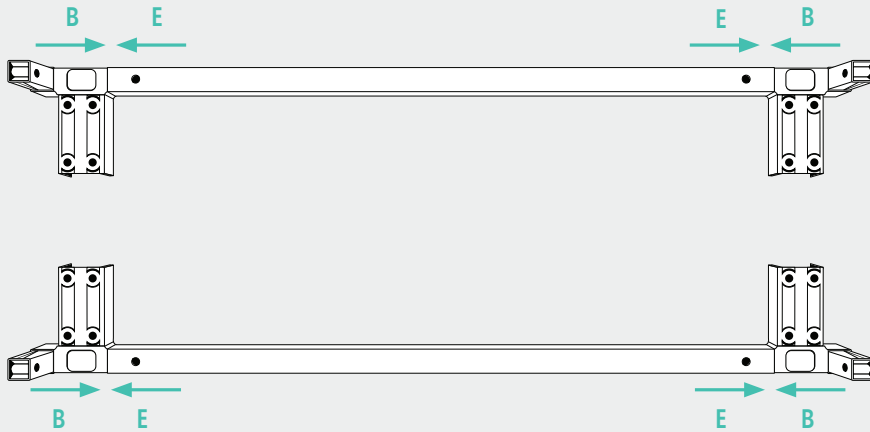

- 2 Connect the Base Width Supports (F) to the Base Connectors (B) as seen below.

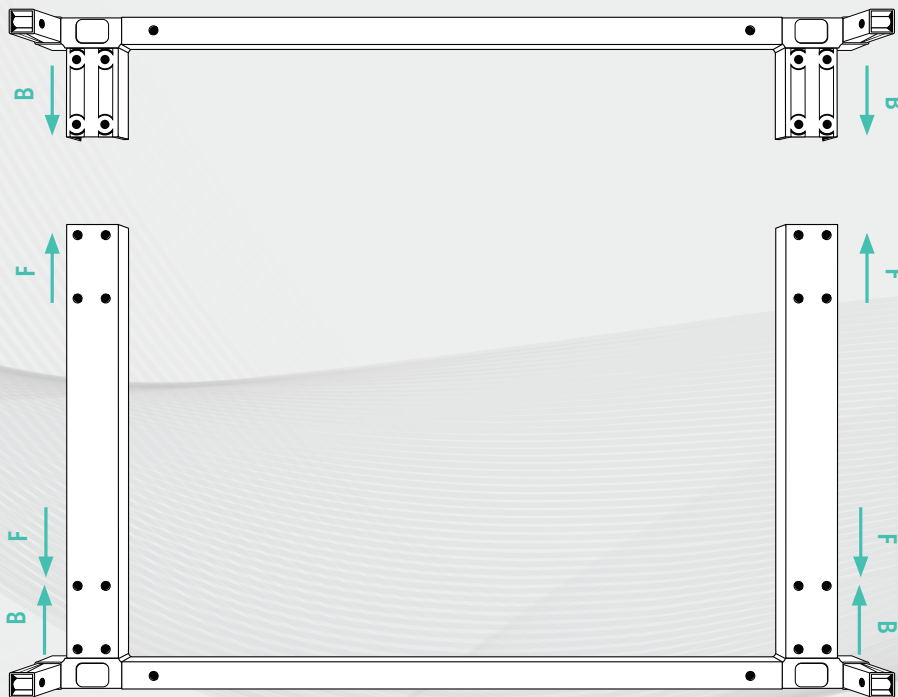

ASSEMBLY STEPS CONT.

- 3 Flip the base frame over and place the wheels on the designated spots. Place 4 of the Base bolts (K) up through the frame and use a Nut (L) on each to secure to the wheel. Tighten with the appropriate tool until firmly secured. Repeat for the 3 remaining wheels.

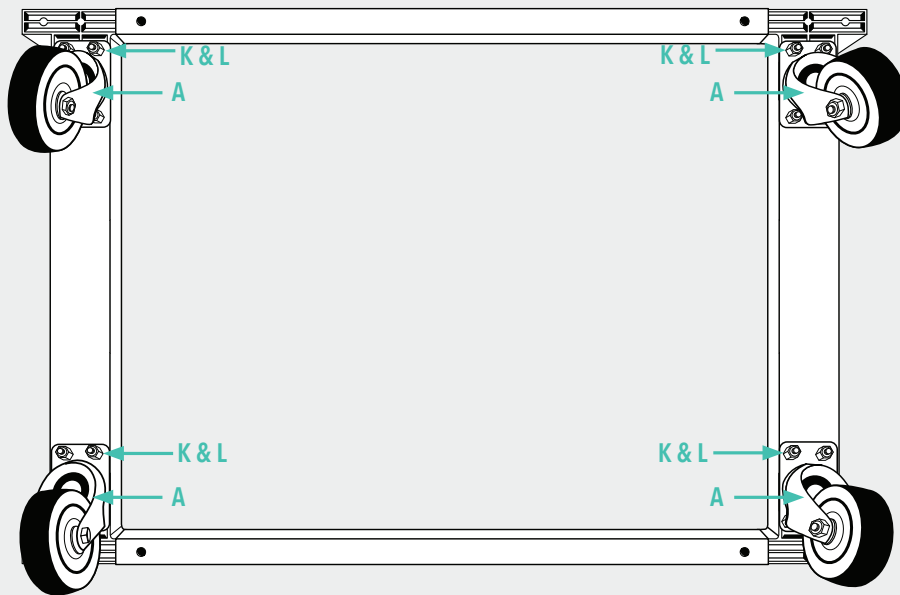

- 4 Insert four of the Frame Bolts (J) up through the Base Length Supports (E) securing with four Nuts (L). Use the appropriate tool to tighten.

You should now have a sturdy base to begin building your 30 Layer Cooling Cart.

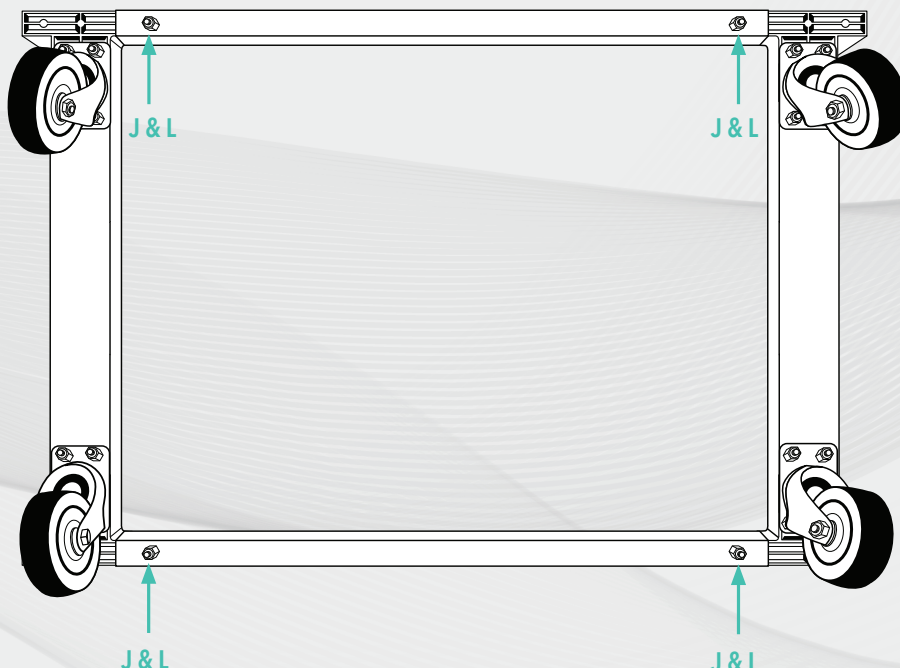

ASSEMBLY STEPS CONT.

THE VERTICAL SUPPORTS

- 5 Insert the four Vertical Supports (I) into the top of the base connectors (B). The shelving holes should face inwards towards the Base Width Supports (F) with the larger rectangles at the top.

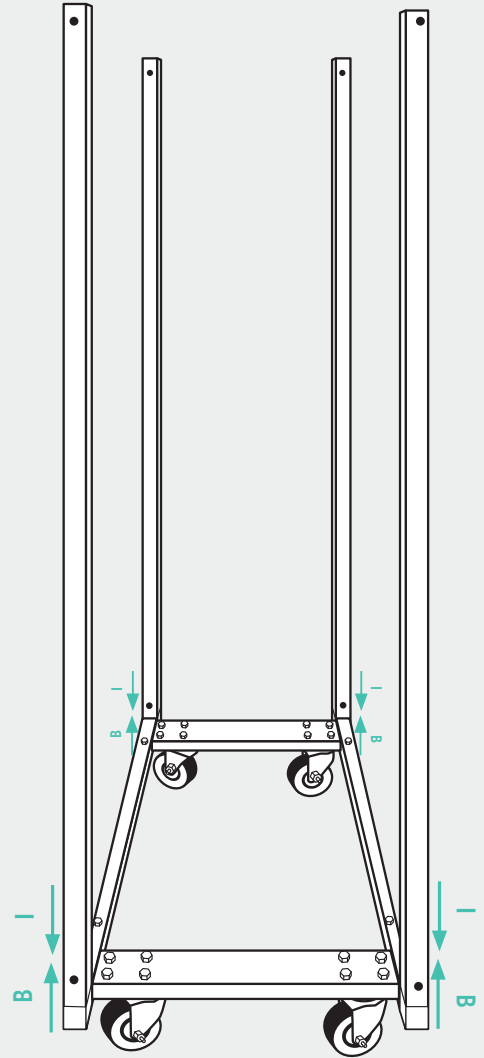

- 6 Insert four of the Frame Bolts (J) through the Vertical Supports and use a nut (L) on each to secure. Use the appropriate tool to tighten.

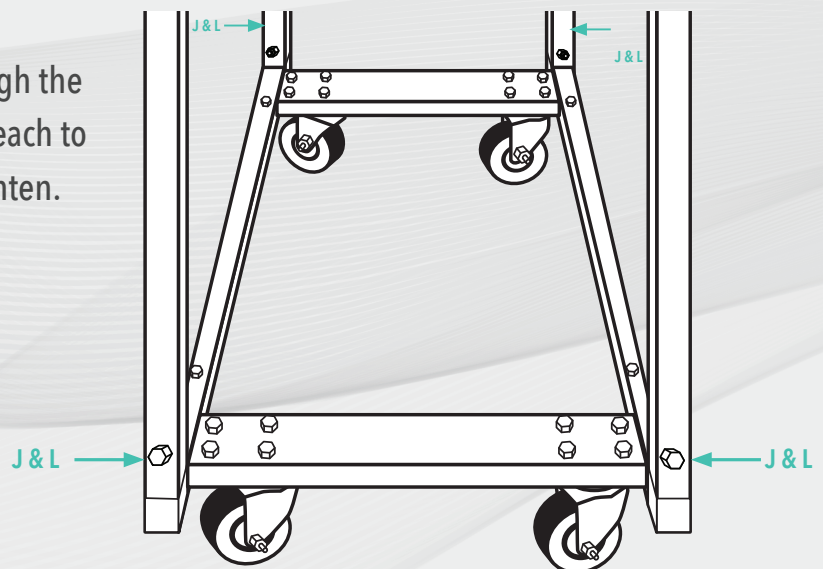

ASSEMBLY STEPS CONT.

THE TOP

- 7 To begin building the top frame, connect the Top Length Supports (D) to the Top Connectors (C).

Ensure that the orientation of each part matches the diagram to ensure the bolts can be inserted in step 11.

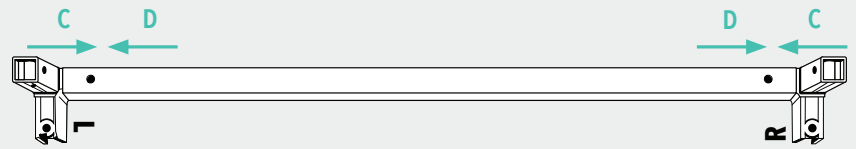

- 8 Connect the Top Width Supports (G) to the Top Connectors (C) to complete the frame.

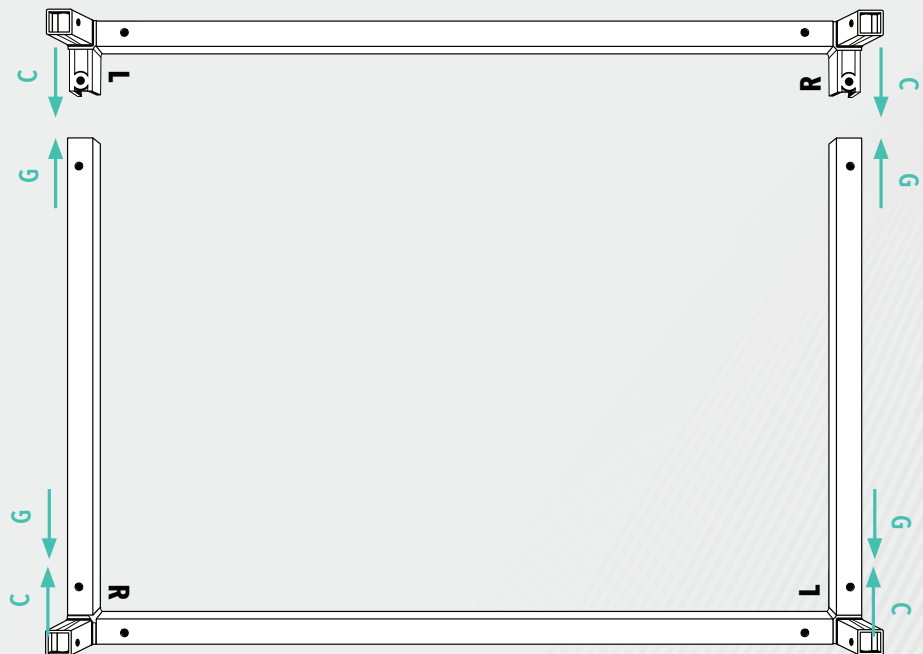

- 9 Insert eight of the Frame Bolts (J) up through the Top Frame, securing with eight Nuts (L) and use the appropriate tool to tighten.

The Top Frame is now complete and ready to be connected to the main frame.

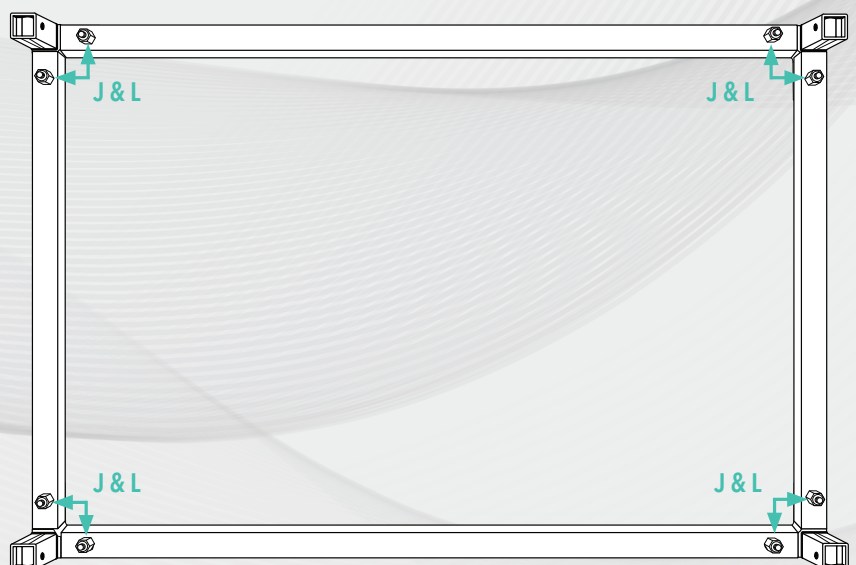

ASSEMBLY STEPS CONT.

- 10 Align the Top Frame with the main frame and insert each Top Connector (C) into the appropriate Vertical Support (I).

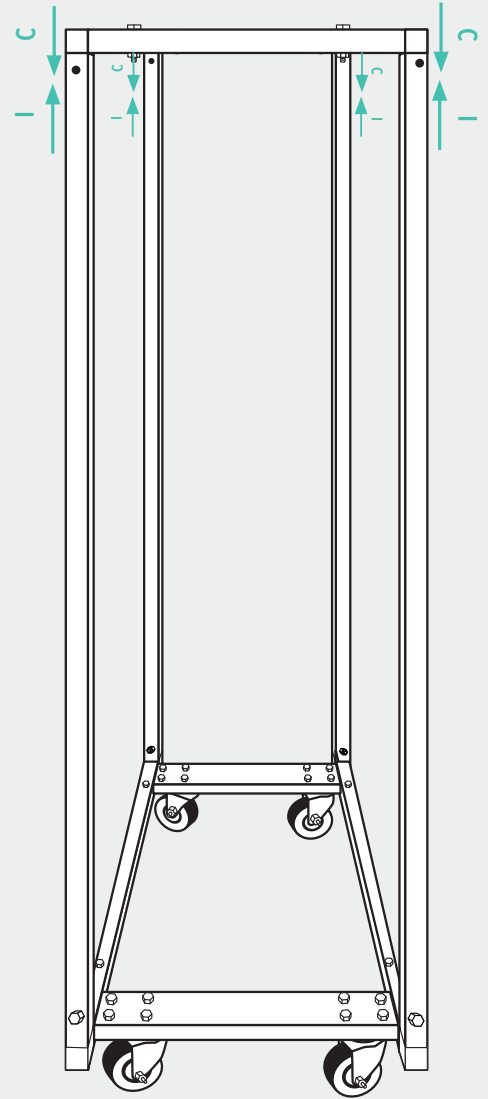

- 11 Secure the Top Frame to the Vertical Supports (I) by inserting a Frame Bolt (J) and Nut (L) through each.

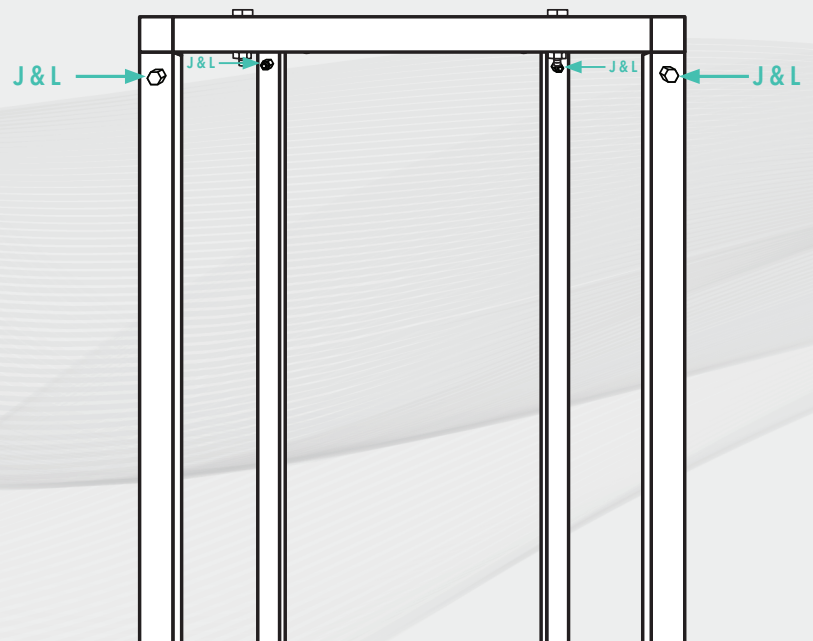

ASSEMBLY STEPS CONT.

THE SHELVES

- 12 To connect your Shelves (H) to the Vertical Supports (I), slide the metal tab on each side of the Shelf (H) into the top rectangular hole of each Vertical Support (I).

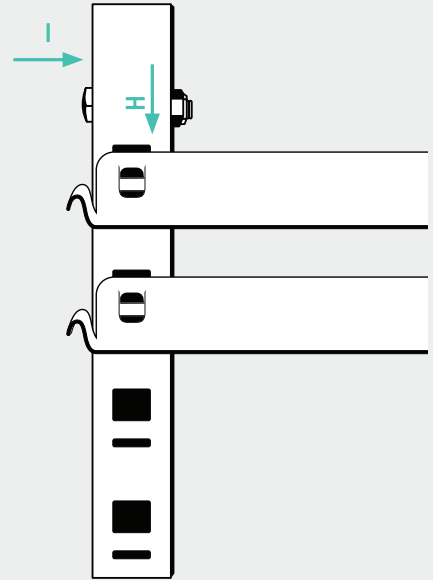

- 13 Repeat for all shelves on both sides of the trolley cart.

Congratulations, your 30 Layer Cooling Cart for 60-CUD is now complete :)

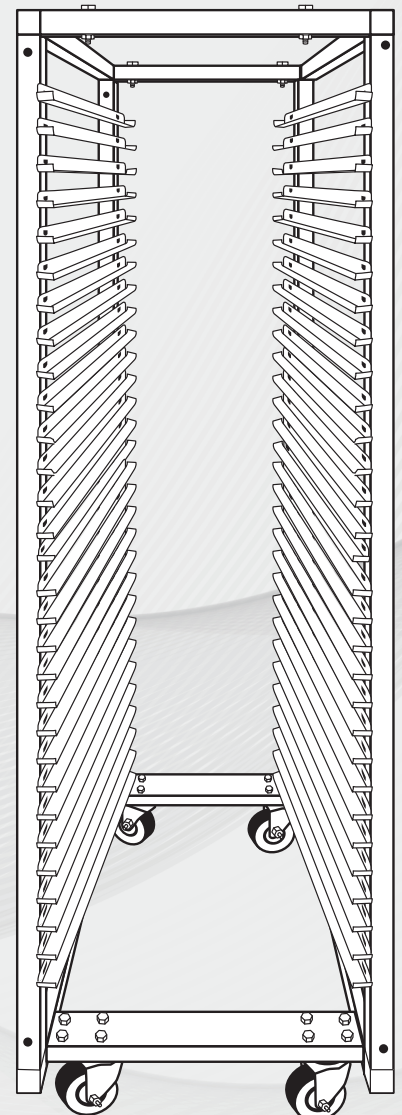

3-YEAR COMMERCIAL WARRANTY

This Commercial Warranty applies to all physical goods (product/s) purchased from the company BenchFoods or your Authorized Retailer.

1. WHAT DOES THIS WARRANTY COVER?

This Commercial Warranty covers any defects in material or workmanship under normal commercial use during the Warranty Period. During the Warranty Period, BenchFoods or your Authorized Retailer will repair, at no charge, products or parts of a product that prove defective under normal commercial use.

2. WHAT WILL WE DO TO CORRECT PROBLEMS?

BenchFoods or your Authorized Retailer will action 1 of 3 scenarios based on the defect and the product purchased;

1. Send a brand-new replacement of the defective product. **Does not apply for custom industrial orders*
 2. If the defective part of the product can be identified, we will ship the replacement part and have a service technician come on-site to replace and install it once it has arrived.
 3. Send out a service technician to investigate the defect. Once the issue has been identified, the technician will either fix the defect immediately or notify BenchFoods or your Authorized Retailer of replacement parts needed. If the latter, BenchFoods or your Authorized Retailer will ship the required replacement parts to the service address. The technician will then return on-site to service and fix the product.
-

3. HOW LONG DOES THE COVERAGE LAST?

The Warranty Period for Commercial and Industrial Dehydrators, as well as their accessories, is 3 years from the original date of purchase. Individual Dehydrator Parts purchased are not covered by warranty unless they are received through a warranty claim on a previously purchased product. In this case, a replacement product or part/s assumes the remaining warranty of the original Physical Goods or 180 days from the date of replacement or repair, whichever is longer.

4. WHAT DOES THIS WARRANTY NOT COVER?

This Commercial Warranty does not cover defects or malfunction caused by misuse, abuse or improper maintenance, failure to follow operating instructions, or use with equipment with which it is not intended to be used. It doesn't cover cosmetic or incidental damages. Also, the warranty will not apply to damage caused by unauthorized alteration, modification or repair of the product.

5. WHAT DO YOU HAVE TO DO?

To obtain warranty service, firstly contact us to determine the problem and the most appropriate solution for you. In most cases, technical problems can be corrected over the phone. Tech support can be reached via telephone or email.

Email info@benchfoods.co



BENCHFOODS

UNITED STATES:

(972) 737-1282 | 4514 MAXEY RD, SUITE A - D, ALVARADO, TX, 76009

CANADA:

(604) 800-7466 | SUITE 900/2025 WILLINGDON AVE,
BURNABY, BC V5C 0J3

UNITED KINGDOM:

0203 879 4355 | 27 OLD GLOUCESTER STREET, LONDON WC1N 3AX

AUSTRALIA:

(07) 5526 2335 | 8/17 INDY COURT, CARRARA, QLD, 4210

NEW ZEALAND:

(09) 870-3320 | SUITE 13044, 17B FARNHAM STREET, PARNELL,
AUCKLAND, 1052

INFO@BENCHFOODS.CO

[BENCHFOODS.CO](https://www.benchfoods.co)