

Wicker Sofa Set

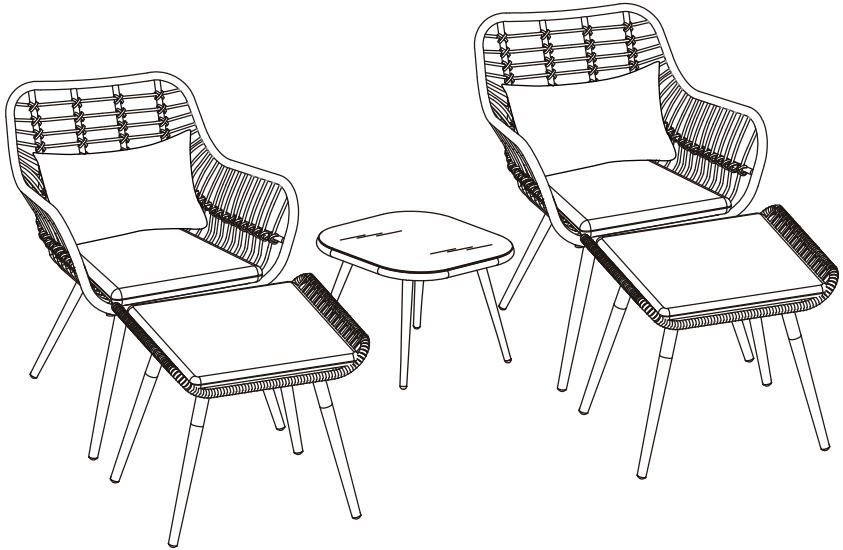



**IMPORTANT, RETAIN FOR
FUTURE REFERENCE:
READ CAREFULLY.**

Safety

- For domestic use only.
- Always use on firm level ground.
- Don't tighten all the bolts before the product is fully assembled.
- It would be useful to ask someone to help you assemble the product.
- Periodic structural checks of this product should be undertaken, do not use if you have any doubts about its fitness for purpose.
- Do not stand on the seat.
- Do not sit on the armrest.
- Do not let children play with this product.
- Maximum load per seat: 250 lbs.

At the beginning of the season

- Check to ensure that all components and fixings of this product are secure, do not use if you have any doubts about its fitness for purpose.

At the end of the season







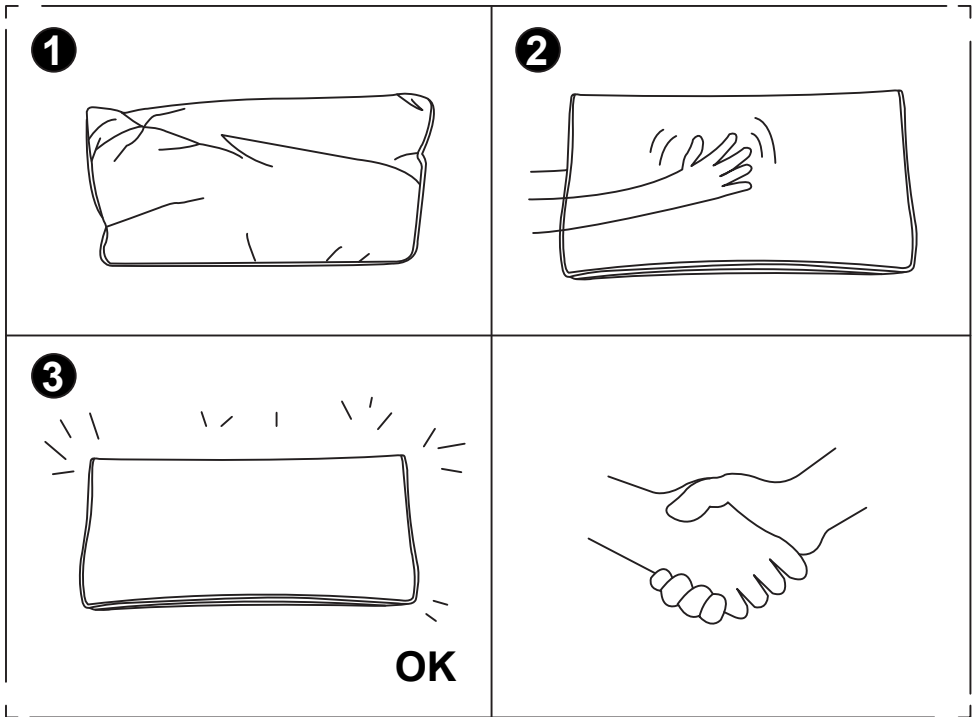

- This product should be stored under cover during prolonged spells of adverse weather (wet or cold) and also during the winter (ideally in a garden shed or garage).
- Always clean and dry thoroughly before storage.

Tips for Cushions

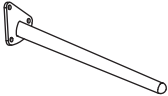
In order to compress the package, we put the cushions in the gap of some parts. So there may be crinkle on the fabric. Don't worry. Just flap every corner of the cushion evenly and it will get back into its original shape soon.



COMPONENT LIST - ARMCHAIR*2

Item no.	Reference Image	Description	Qty.
B		Chair Seat	1
E		Front Leg	2
F		Back Leg	2
K		Chair Seat Cushion	1
J		Pillow	1
M		M6X20 Head Cap Screws	12
O		Washer	12
L		Allen Key	1

NOTE:

Do NOT tighten any screws fully first until you have tightened all the screws.

This may cause the frame to warp.

If there is still wobbles or screw holes cannot be aligned, loosen the screws and tighten sequentially.

If the Chair is not stable it could lead to damage to the product.

1

Attach the Front Legs (E) to the Chair Seat (B) by securing with M6X20 Head Cap Screws (M) and Washers (O). Do this in 2 places.

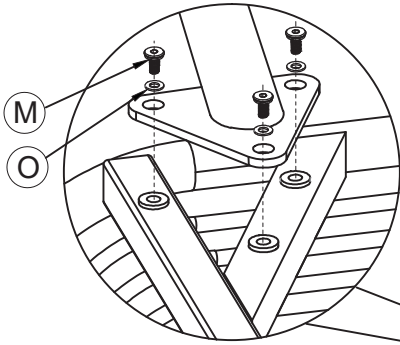

 Repeat
x2

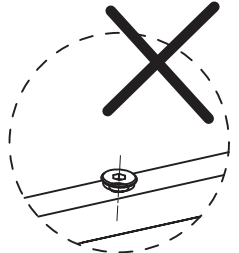
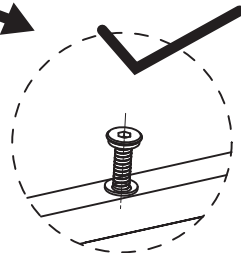
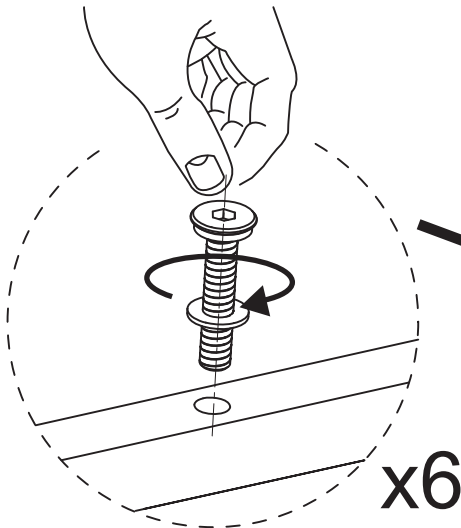
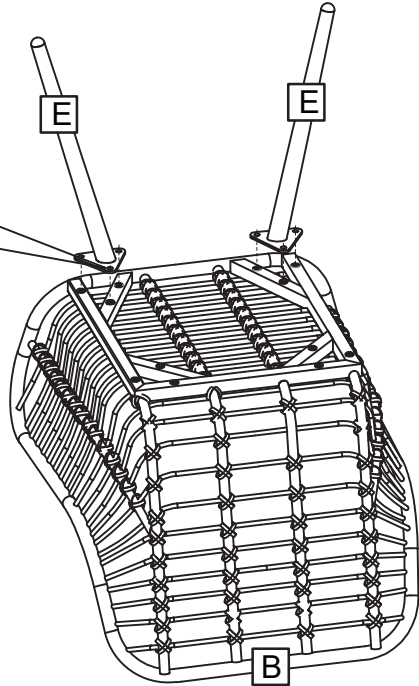

NOTE: DO NOT TIGHTEN THE SCREWS COMPLETELY.

2

Attach the Back Legs (F) to the Chair Seat (B) by securing with M6X20 Head Cap Screws (M) and Washers (O). Do this in 2 places.

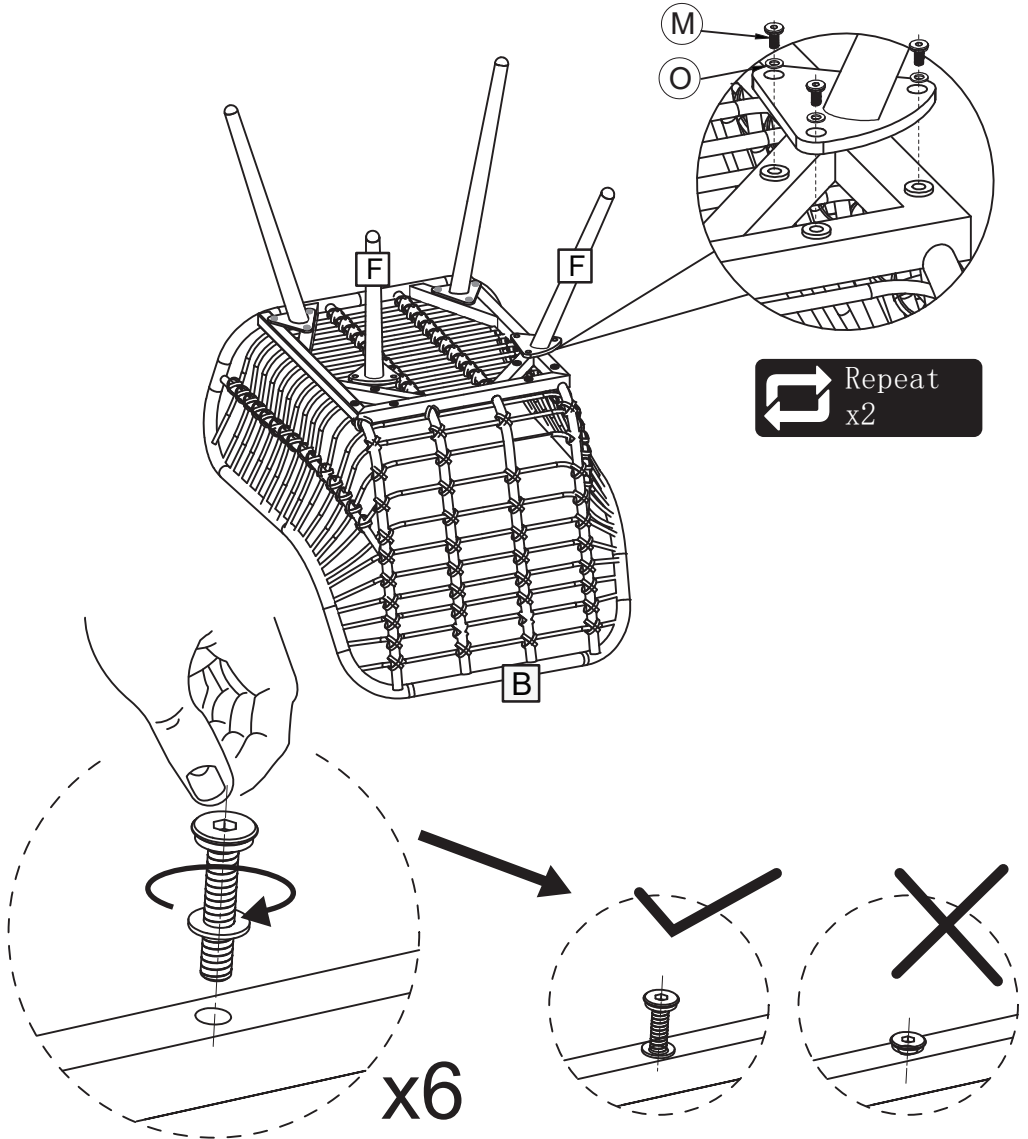

NOTE: DO NOT TIGHTEN THE SCREWS COMPLETELY.

3

Tighten all 12 Screws into place with Allen Key (L).

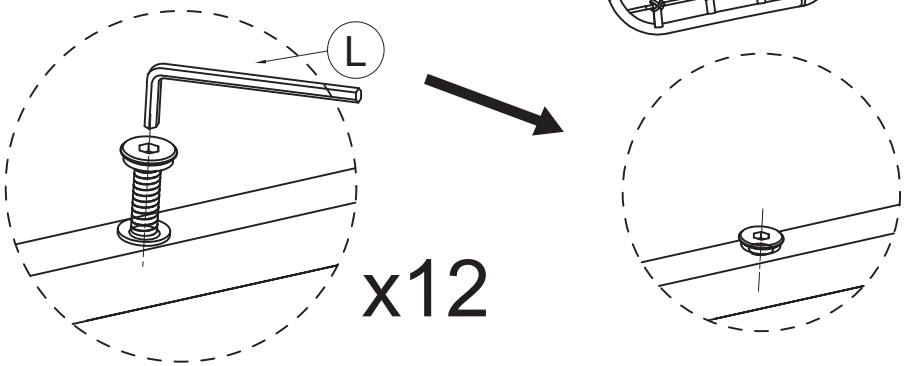
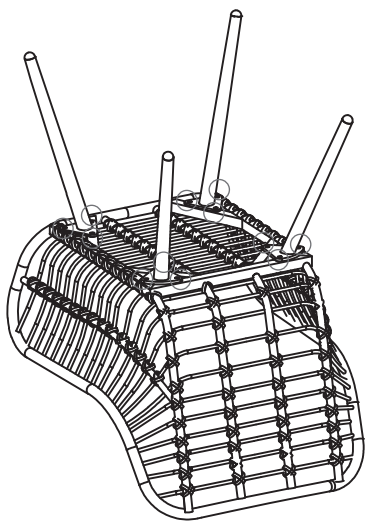



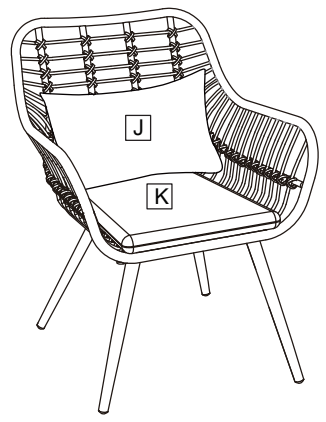

NOTE: IF ANY SCREW HOLES CANNOT BE ALIGNED, LOOSEN ALL THE SCREWS AND GO BACK STEP 1 AND RESTART ASSEMBLY.

4

Place the chair on a level surface, and put the Pillow (J) and Seat Cushion (K) on the chair. Now your chair is ready for use.

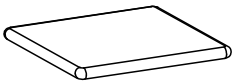
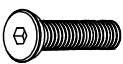

COMPONENT LIST - OTTOMAN*2

Item no.	Reference Image	Description	Qty.
Q		Top Panel	1
U		Ottoman Leg	4
W		Ottoman Cushion	1
M		M6X20 Head Cap Screws	12
O		Washer	12
L		Allen Key	1

NOTE:

Do NOT tighten any screws fully first until you have tightened all the screws.

This may cause the frame to warp.

If there is still wobbles or screw holes cannot be aligned, loosen the screws and tighten sequentially.

If the Ottoman is not stable it could lead to damage to the product.

1

Attach the Ottoman Legs (U) to the Top Panel (Q) by securing with M6X20 Head Cap Screws (M) and Washers (O). Do this in 4 places.

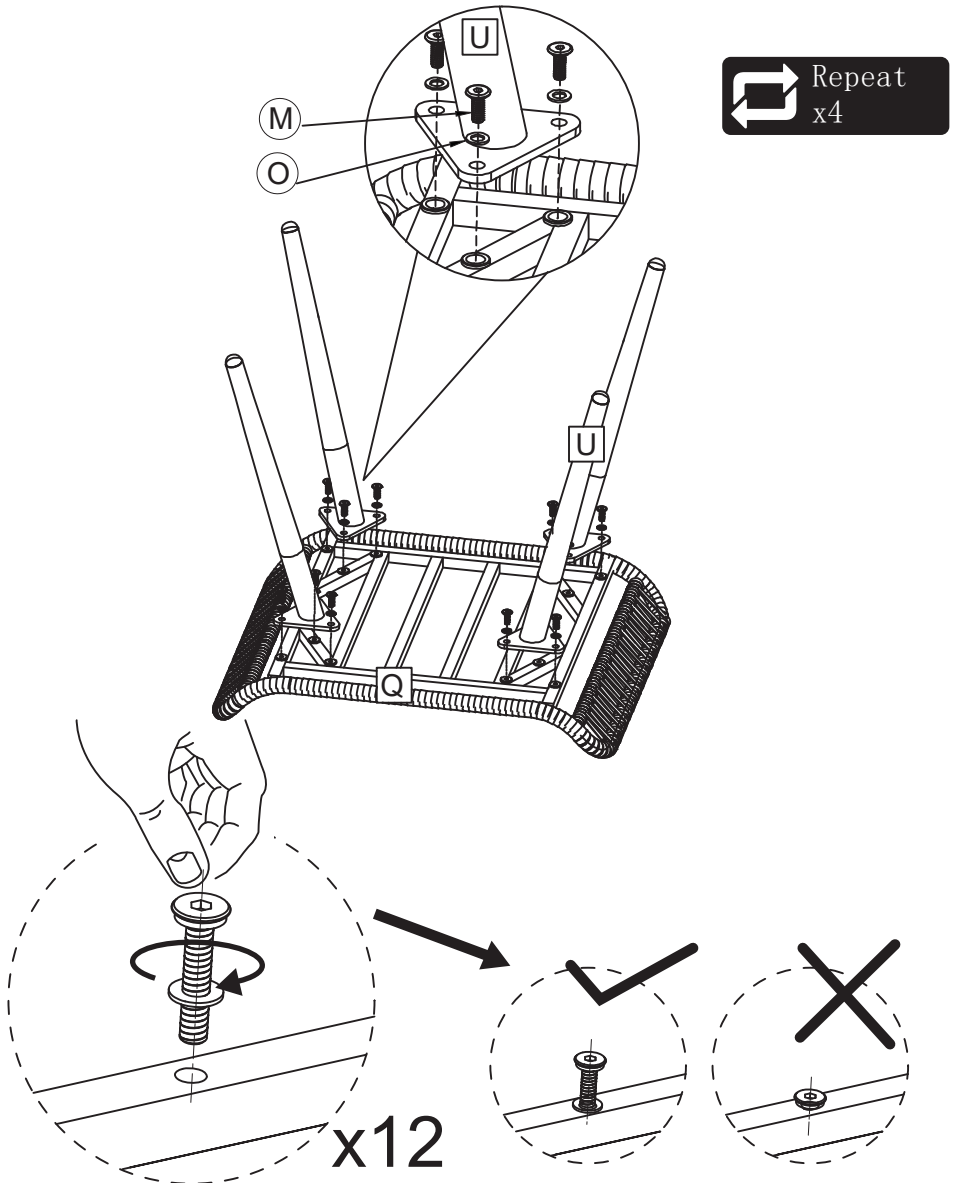

NOTE: DO NOT TIGHTEN THE SCREWS COMPLETELY.

2

Tighten all 12 Screws into place with Allen Key (L).

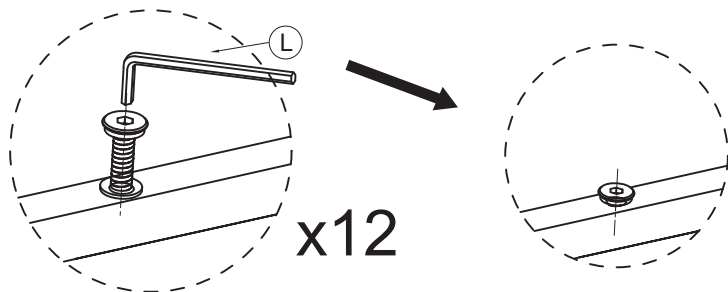



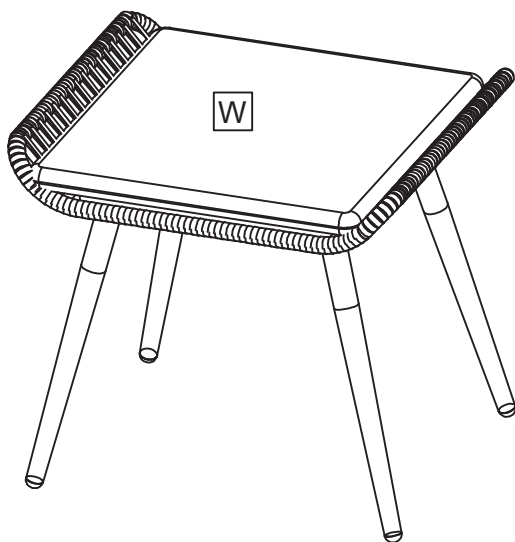

NOTE: IF ANY SCREW HOLES CANNOT BE ALIGNED, LOOSEN ALL THE SCREWS AND GO BACK STEP 1 AND RESTART ASSEMBLY.

3

Place the Ottoman on a level surface, and put the Ottoman Cushion (W) on the Ottoman. Now your Ottoman is ready for use.

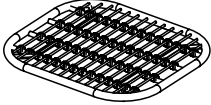

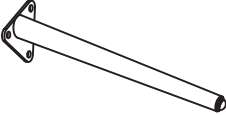
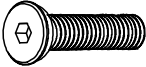
COMPONENT LIST - TABLE

Item no.	Reference Image	Description	Qty.
C1		Table top frame	1
D1		Table glass	1
N		Table leg	4
M		M6X15 Head Cap Screws	12
O		Washer	12
L		Allen Key	1

NOTE:

Do NOT tighten any screws fully first until you have tightened all the screws.

This may cause the frame to warp.

If there is still wobbles or screw holes cannot be aligned, loosen the screws and tighten sequentially.

If the Table is not stable it could lead to damage to the product.

1

Attach the Table Legs (N) to the Table Top Frame (C1) by securing with M6X15 Head Cap Screws (M) and Washers (O). Do this in 4 places.

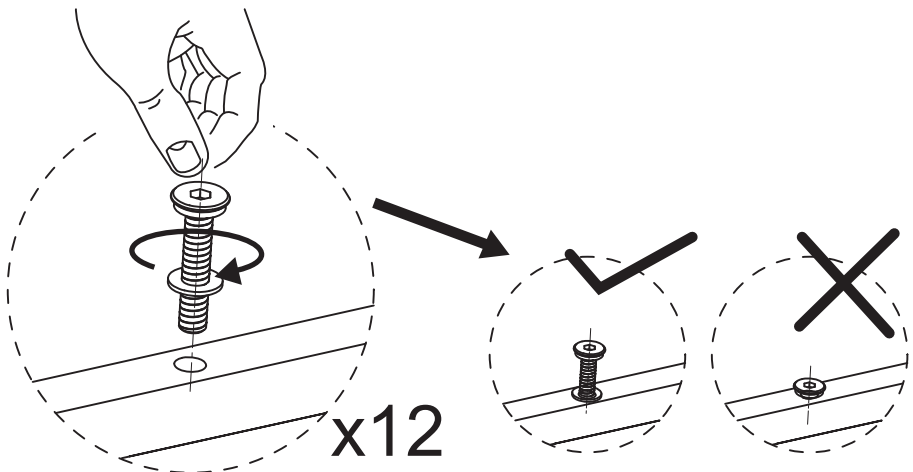
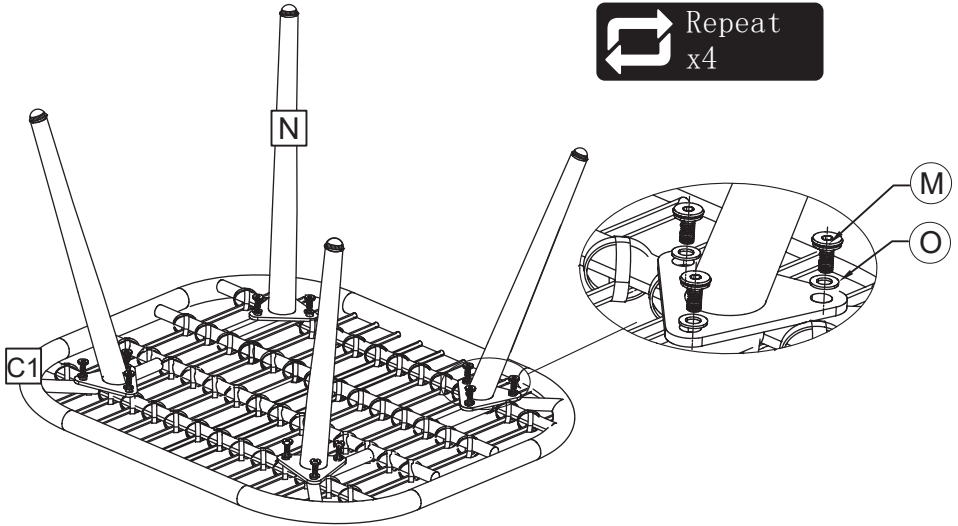

NOTE: DO NOT TIGHTEN THE SCREWS COMPLETELY.

- 2** Tighten all 12 Screws into place with Allen Key (L).

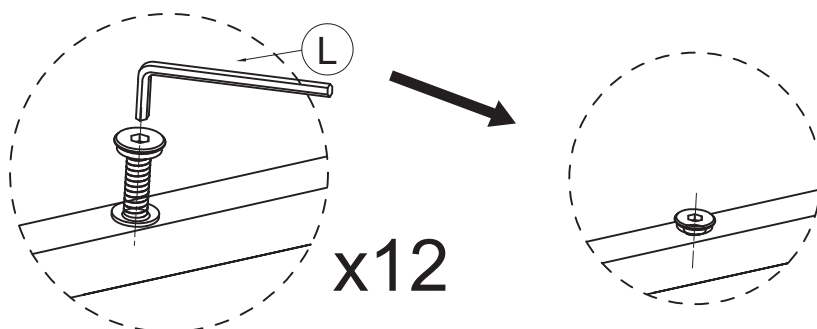

NOTE:IF ANY SCREW HOLES CANNOT BE ALIGNED, LOOSEN ALL THE SCREWS AND GO BACK STEP 1 AND RESTART ASSEMBLY.

- 3** Place the table on a level surface.
Put the Table Glass (D1) on the Table Top.

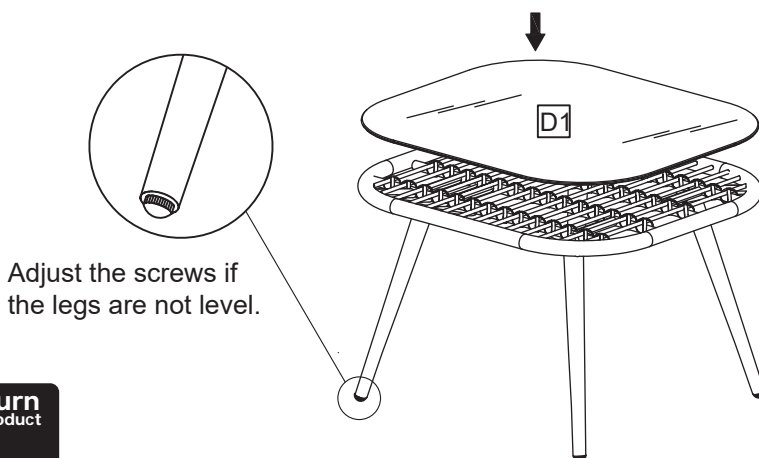

NOTE: Be careful and do not scratch the glass top during the assembling.