

INSTRUCTION MANUAL

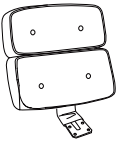

Parts List

A × 1



B × 1



C × 1



D × 1



E × 1



F × 5



G × 1



H × 5



1 × 4



M8x20mm

2 × 4



M6x20mm

3 × 4



M8x30mm

4 × 5



M6x18mm

5 × 4



M6x30mm

6 × 1



Assembly Instruction

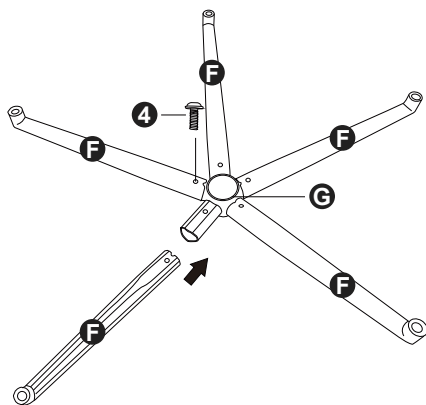
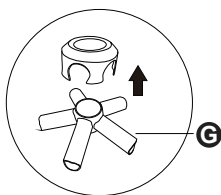

1

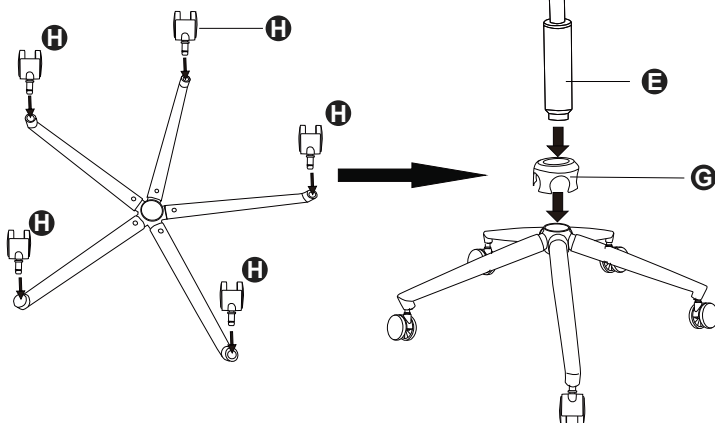

2

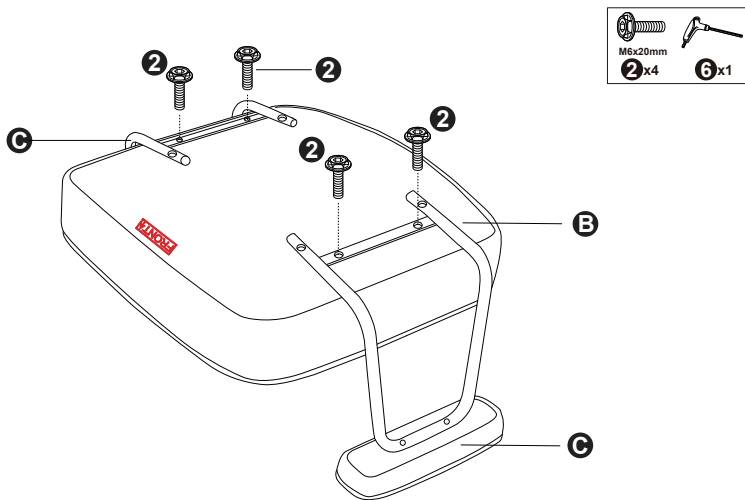

3

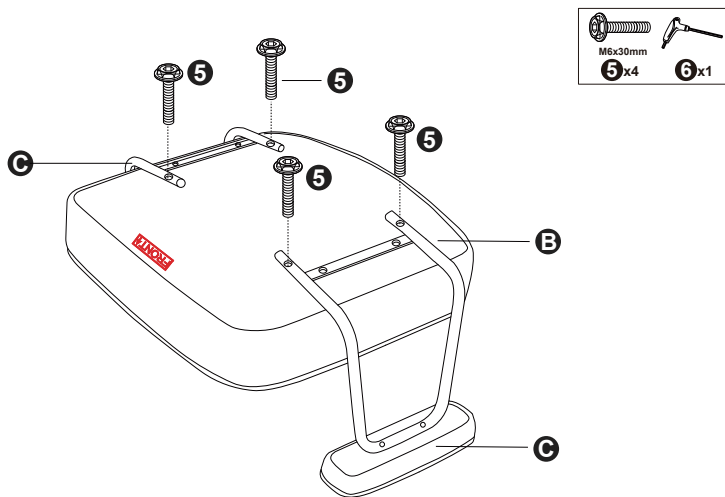

4

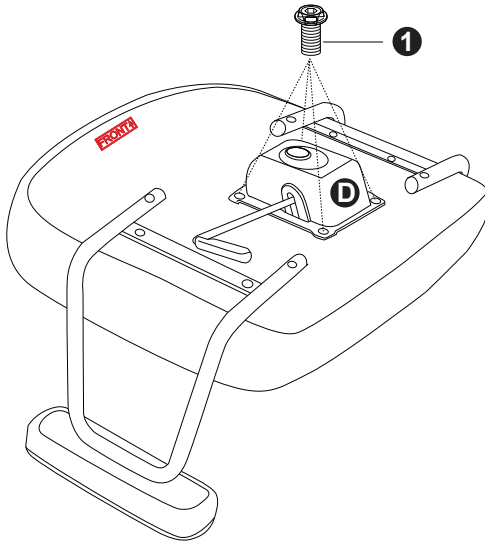
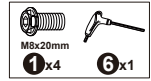

5

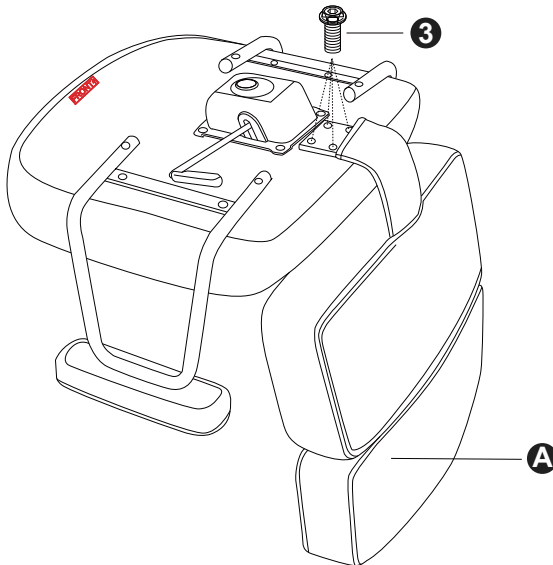
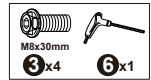

6

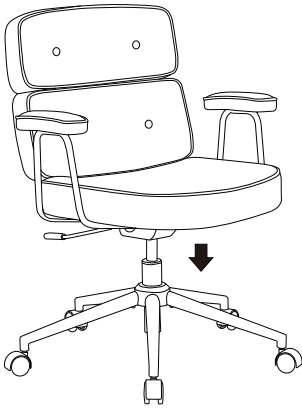

7

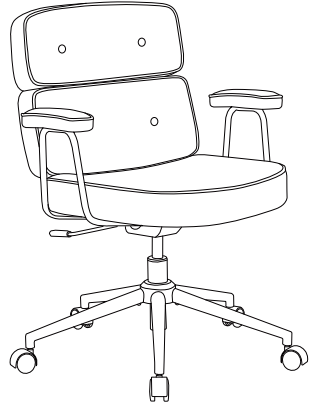

8

Instructions For Use

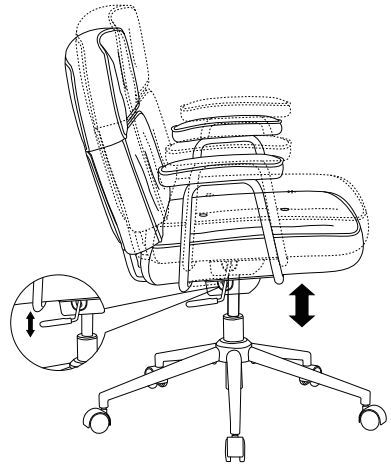
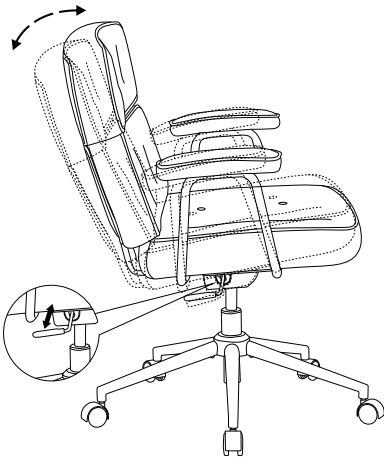

CAUTION:

- * Before using the chair, ensure that all bolts are fully tightened.
- * Lubricate all moving parts and retighten all bolts every 6 months or as needed.

To deodorize the chair, leave it in a shaded and well-ventilated outdoor area for 1-2 days.

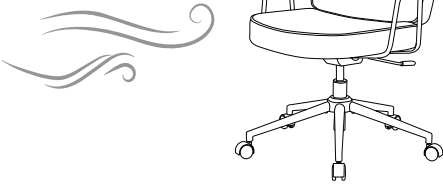

For long-term use, periodically retighten all bolts with the provided Allen Key. Do not use an electric screwdriver, as it may damage the chair. Always tighten the bolts manually.

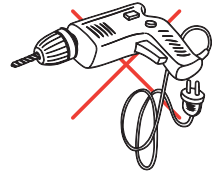

Safety Information



Sit in the center of the chair, with your back against the backrest



Do not sit on the front edge of the chair



Do not stand on the chair



Do not use the chair with more than one person



Do not push the chair around when a person is sitting in it



Do not push down on the backrest when a person is reclined



Do not put your full weight on the backrest.

INSTRUCTION MANUAL

Manual de instrucciones



Lista de piezas

A x1

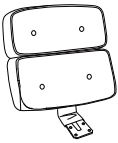

B x1



C x1



D x1



E x1



F x5



G x1



H x5



1 x4



M8x20mm

2 x4



M6x20mm

3 x4



M8x30mm

4 x5



M6x18mm

5 x4



M6x30mm

6 x1



Instrucciones de montaje

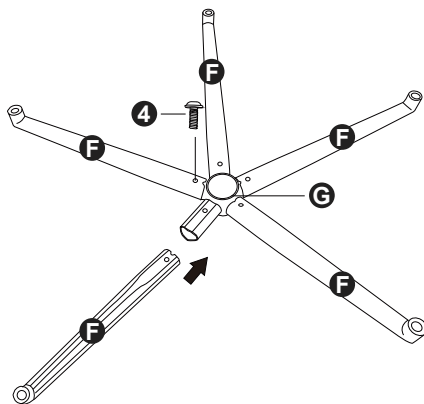
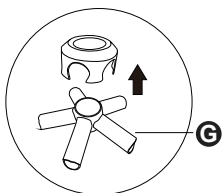
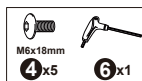

1

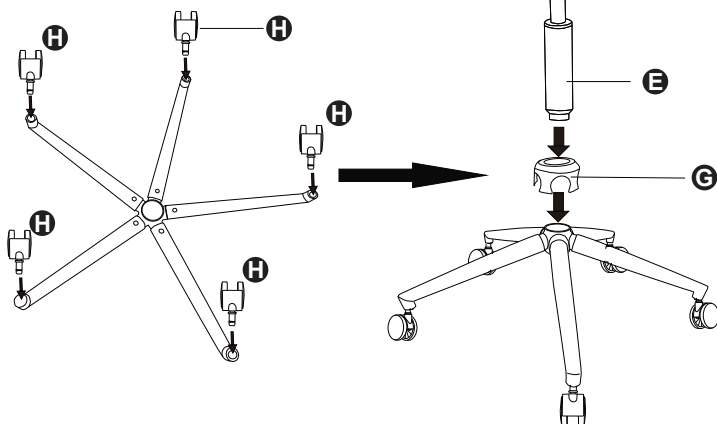

2

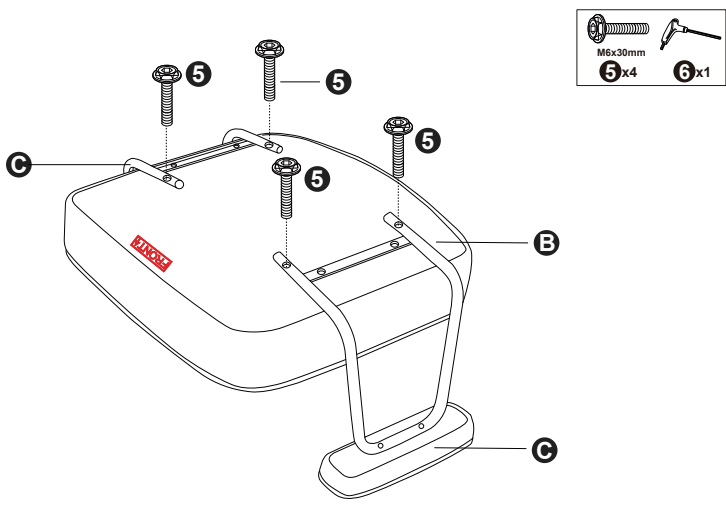
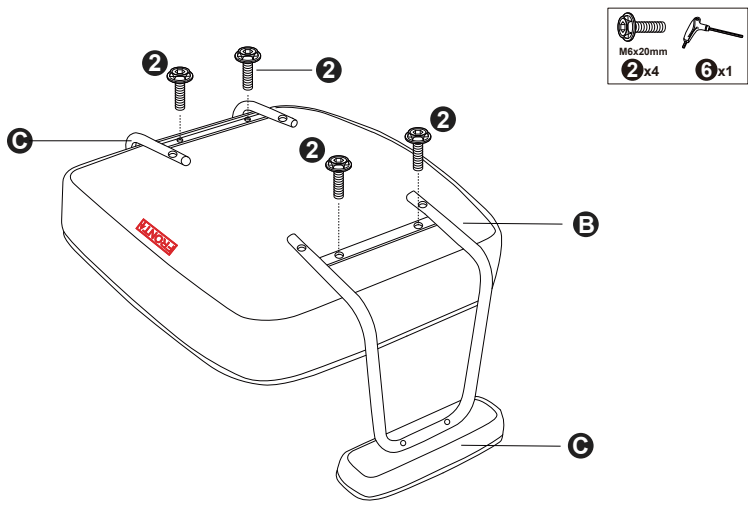

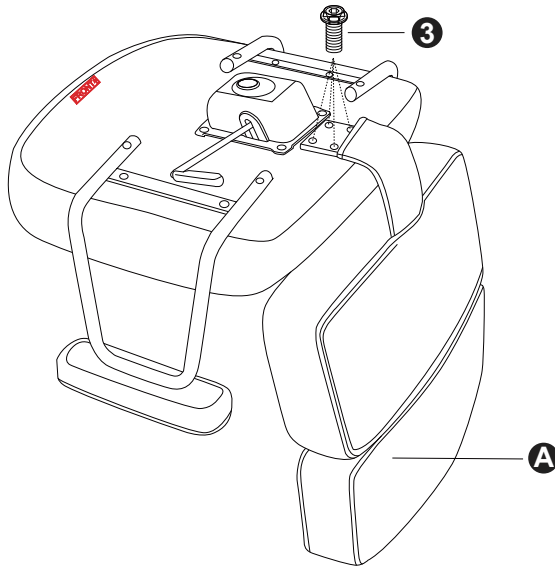
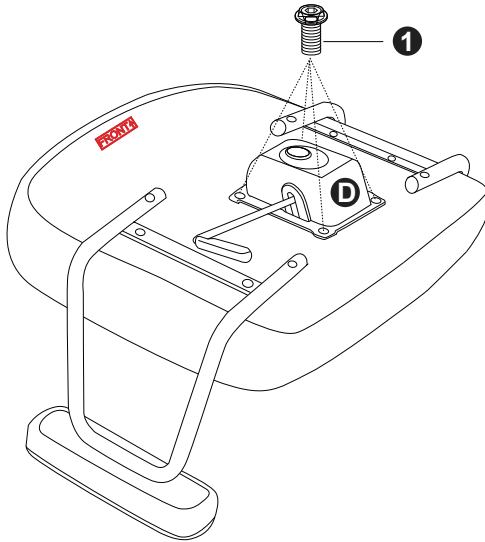

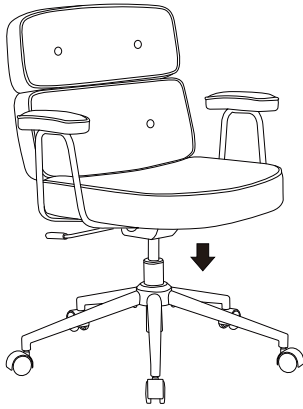

7



8

Instrucciones de uso

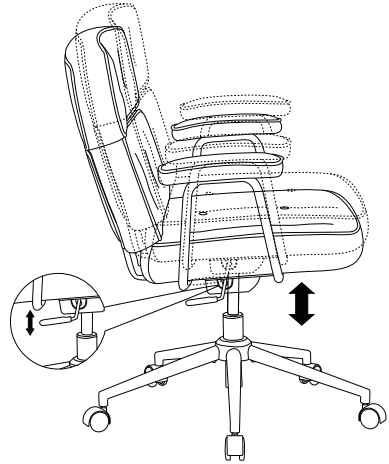

PRECAUCIÓN:

* Antes de usar la silla, verifique que todos los tornillos estén completamente apretados.

* Lubrique las piezas móviles y vuelva a apretar todos los tornillos cada 6 meses o cuando sea necesario.

Para desodorizar la silla, déjela en una zona exterior sombreada y bien ventilada durante 1-2 días.



Para un uso prolongado, apriete periódicamente todos los tornillos con la llave Allen suministrada. No utilice un destornillador eléctrico, ya que podría dañar la silla. Asegúrese de apretar siempre los tornillos manualmente.

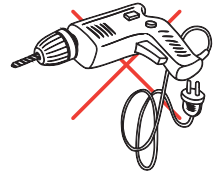

Información de seguridad



Siéntese en el centro de la silla, con la espalda apoyada en el respaldo



No se siente en el borde delantero de la silla



No se suba a la silla



No utilice la silla con más de una persona



No empuje la silla cuando haya una persona sentada en ella



No presione el respaldo cuando la persona esté reclinada



No apoye todo su peso únicamente en el respaldo.

Manual de instrucciones

MODE D'EMPLOI



Liste des Pièces

A x1

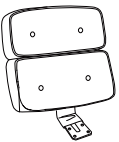

B x1



C x1



D x1

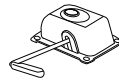

E x1



F x5



G x1



H x5



1 x4



M8x20 mm

2 x4



M6x20 mm

3 x4



M8x30 mm

4 x5



M6x18 mm

5 x4



M6x30 mm

6 x1



Instructions de Montage

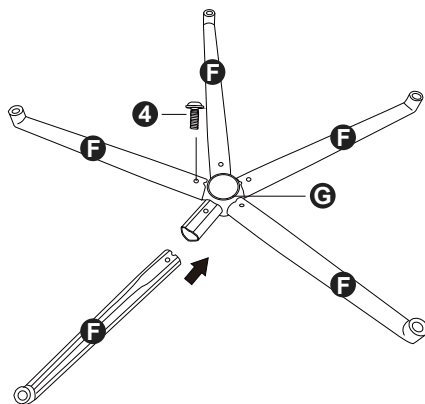
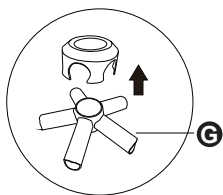

1

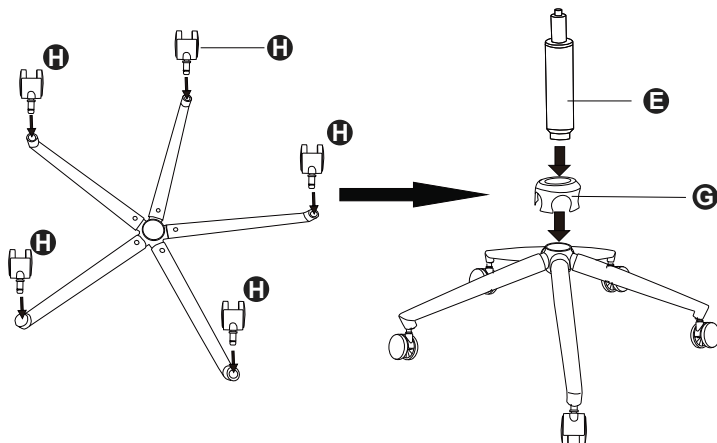

2

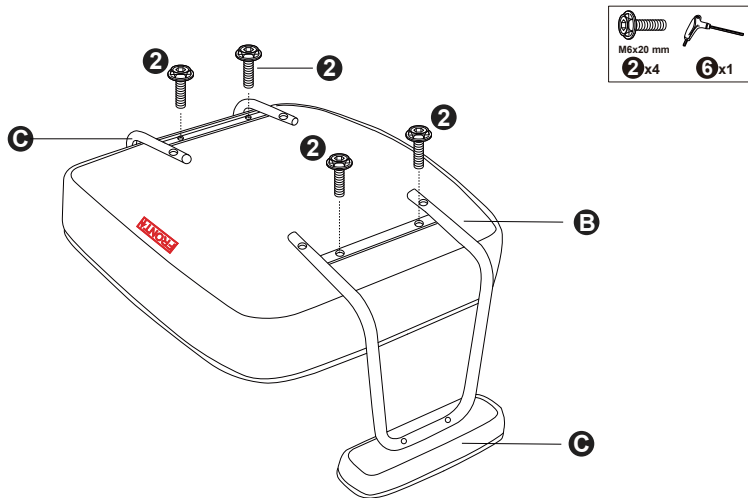

3

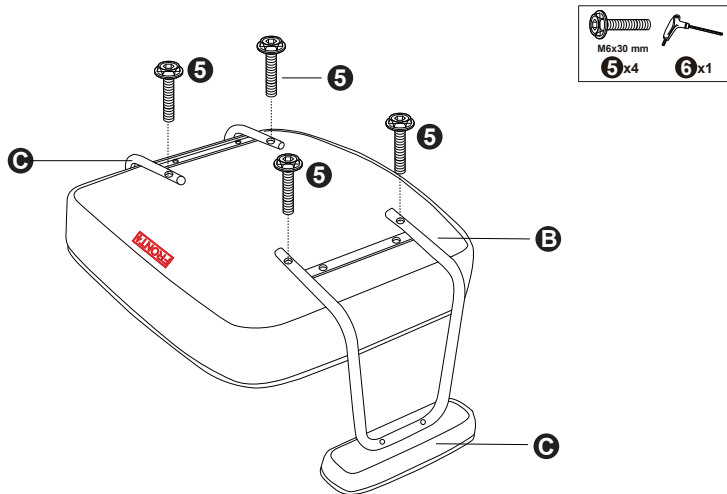

4

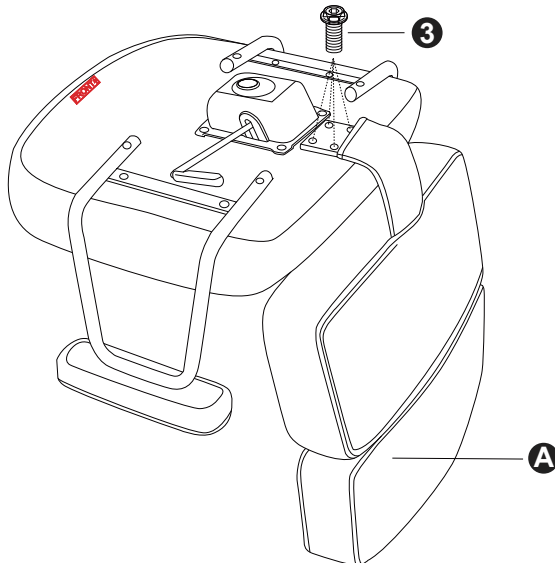
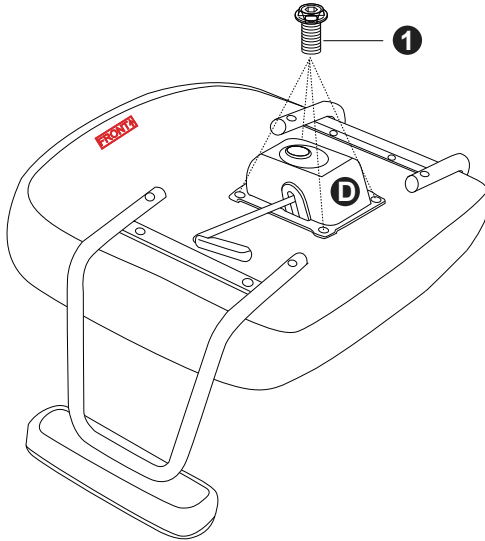

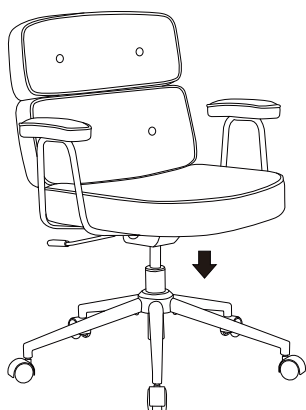

7



8

Instructions d'Emploi

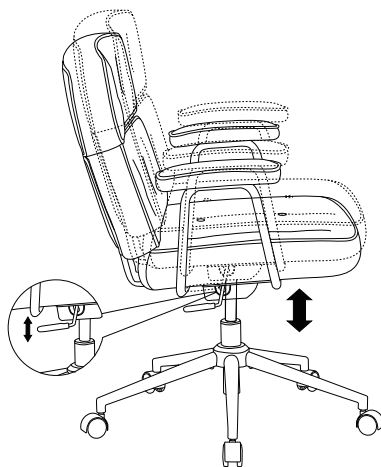
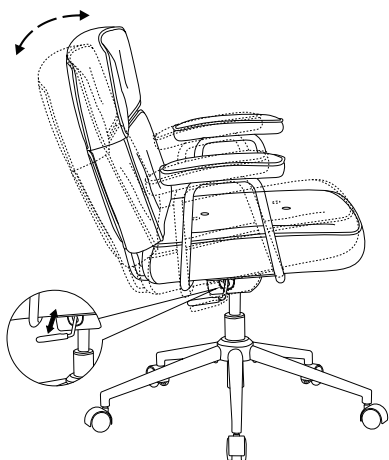

ATTENTION :

* Avant d'utiliser la chaise, assurez-vous que tous les boulons sont complètement serrés.

* Lubrifiez toutes les pièces mobiles et resserrez tous les boulons tous les six mois ou au besoin.

Pour désodoriser la chaise, laissez-la à l'extérieur dans un endroit frais et bien ventilé pendant 1-2 jours.



Pour une utilisation à long terme, resserrez régulièrement tous les boulons en utilisant la clé Allen. N'utilisez pas de tournevis électrique, car cela pourrait endommager la chaise. Serrez toujours les boulons manuellement.

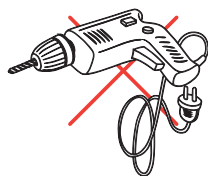

Informations de Sécurité



Asseyez-vous au centre de la chaise, en appuyant votre dos contre le dossier



Ne vous asseyez pas sur le bord avant de la chaise



Ne vous tenez pas debout sur la chaise



N'utilisez pas la chaise avec plus d'une personne



Ne faites pas pivoter la chaise lorsque quelqu'un est assis dessus



Ne poussez pas sur le dossier lorsqu'une personne est allongée



Ne vous appuyez pas de tout votre poids sur le

MODE D'EMPLOI