

Assembly Instruction

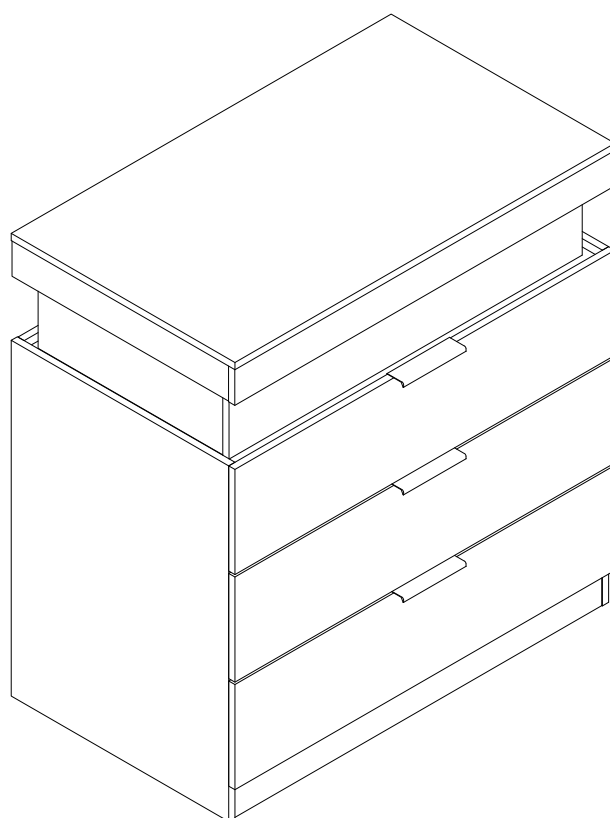

Parts List (EN)

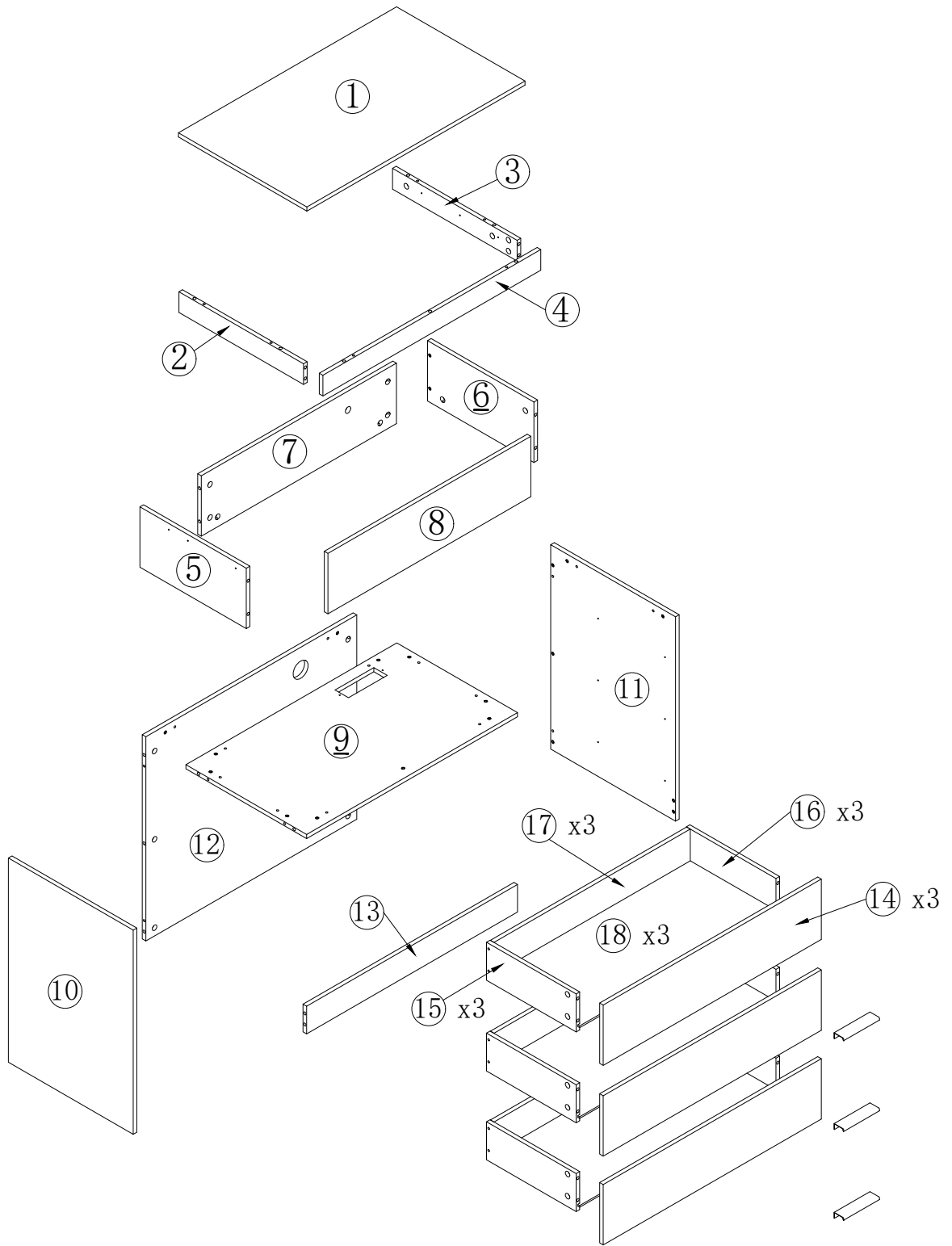



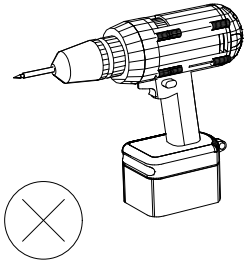
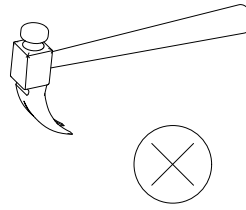
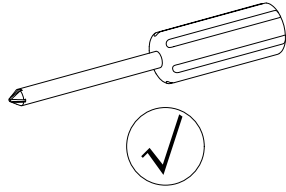
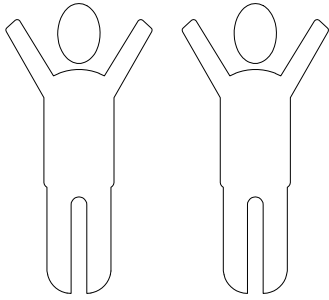

Parts List (EN)

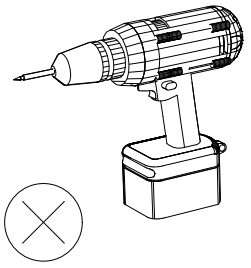
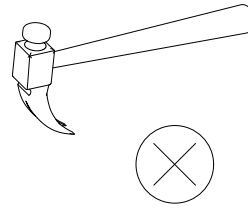
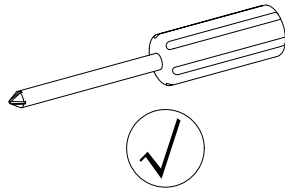
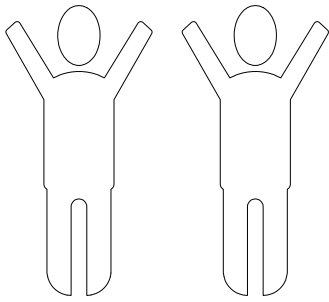

<p>①</p> <p>1PCS</p>	<p>②</p> <p>1PCS</p>	<p>③</p> <p>1PCS</p>	<p>④</p> <p>1PCS</p>
<p>⑤</p> <p>1PCS</p>	<p>⑥</p> <p>1PCS</p>	<p>⑦</p> <p>1PCS</p>	<p>⑧</p> <p>1PCS</p>
<p>⑨</p> <p>1PCS</p>	<p>⑩</p> <p>1PCS</p>	<p>⑪</p> <p>1PCS</p>	<p>⑫</p> <p>1PCS</p>
<p>⑬</p> <p>1PCS</p>	<p>⑭</p> <p>3PCS</p>	<p>⑮</p> <p>3PCS</p>	<p>⑯</p> <p>3PCS</p>
<p>⑰</p> <p>3PCS</p>	<p>⑱</p> <p>3PCS</p>		

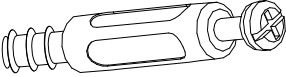
Parts List (EN)

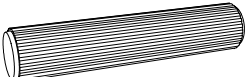
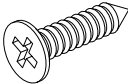
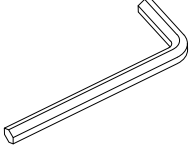
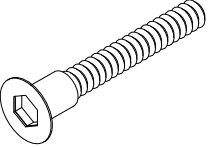
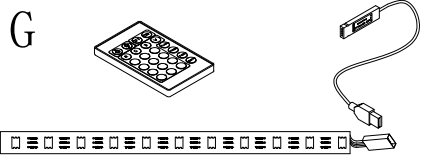

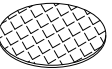
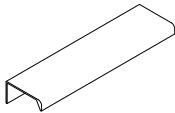
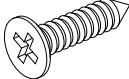
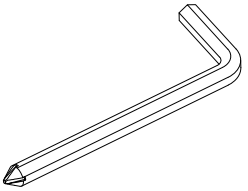
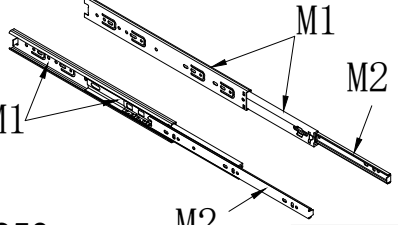
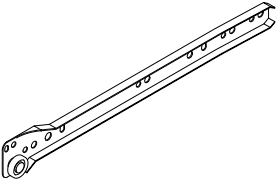
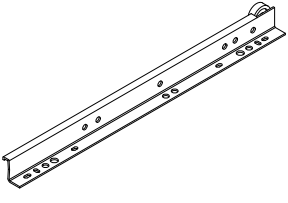
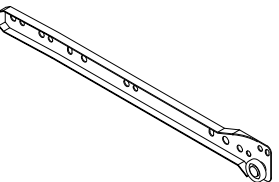
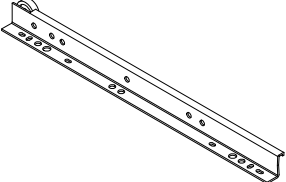

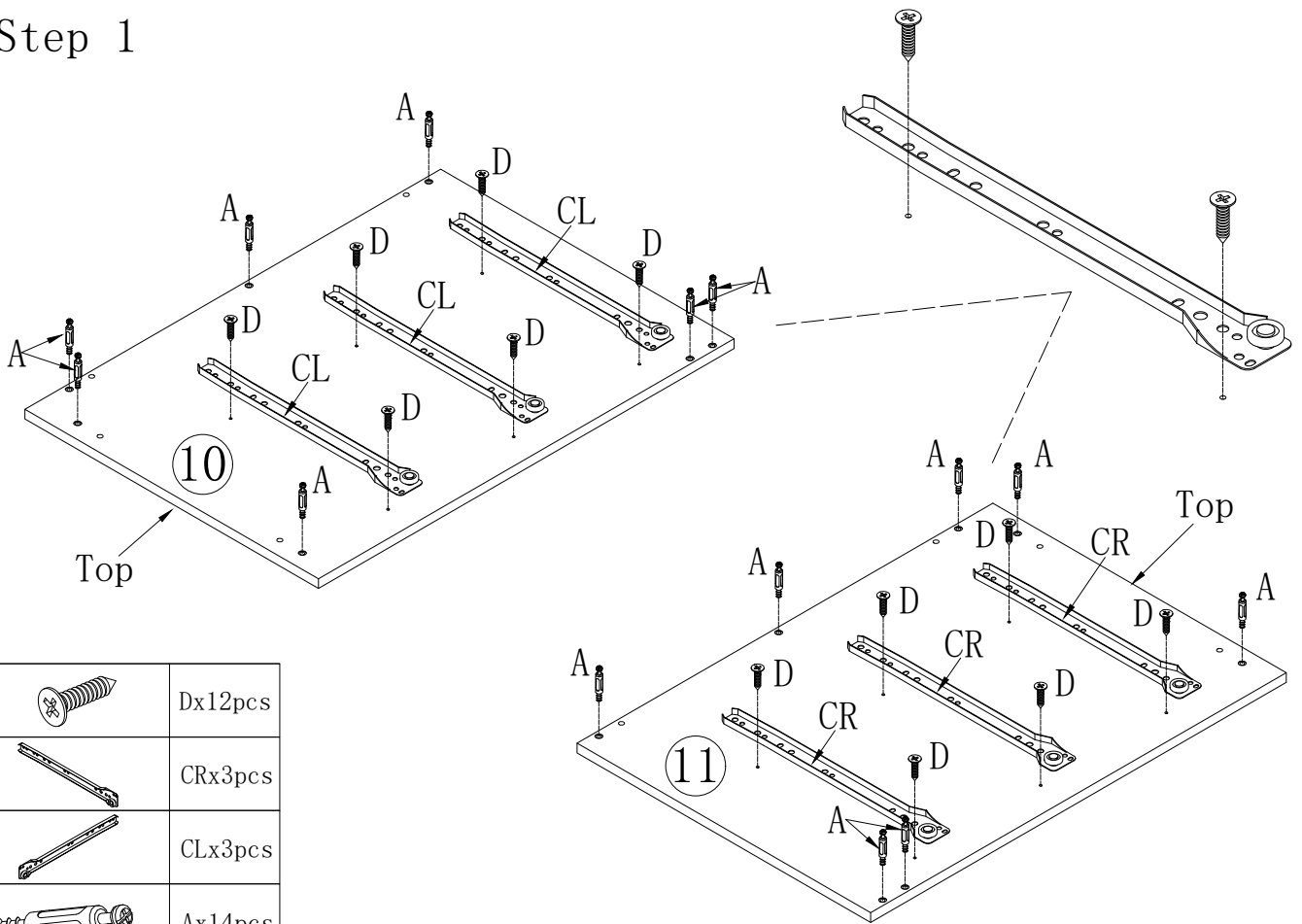

<p>A</p>  <p>∅6*35mm</p> <p>56+2PCS</p>	<p>B</p>  <p>∅15*9.5mm</p> <p>56+2PCS</p>	<p>C</p>  <p>∅6*30mm</p> <p>24+2PCS</p>
<p>D</p>  <p>∅3.5*12mm</p> <p>36+2PCS</p>	<p>E</p>  <p>M3</p> <p>1PCS</p>	<p>F</p>  <p>ST5*50mm</p> <p>12+2PCS</p>
<p>G</p>  <p>Self-affixed soft lamp belt L=2.1m</p> <p>1Sets</p>	<p>H</p>  <p>1PCS</p>	<p>I</p>  <p>∅21mm(White)</p> <p>17+2PCS</p>
<p>J</p>  <p>Handle</p> <p>3 PCS</p>	<p>K</p>  <p>∅3.5*10mm</p> <p>6+1 PCS</p>	<p>L</p>  <p>M4</p> <p>1 PCS</p>
<p>M</p>  <p>L=350mm</p> <p>1 Set</p>	<p>CL</p>  <p>L=300mm</p> <p>3 PCS</p>	<p>DL</p>  <p>L=300mm</p> <p>3 PCS</p>
<p>CR</p>  <p>L=300mm</p> <p>3 PCS</p>	<p>DR</p>  <p>L=300mm</p> <p>3 PCS</p>	

Assembly Steps (EN)

Step 1



	Dx12pcs
	CRx3pcs
	CLx3pcs
	Ax14pcs

Step 2

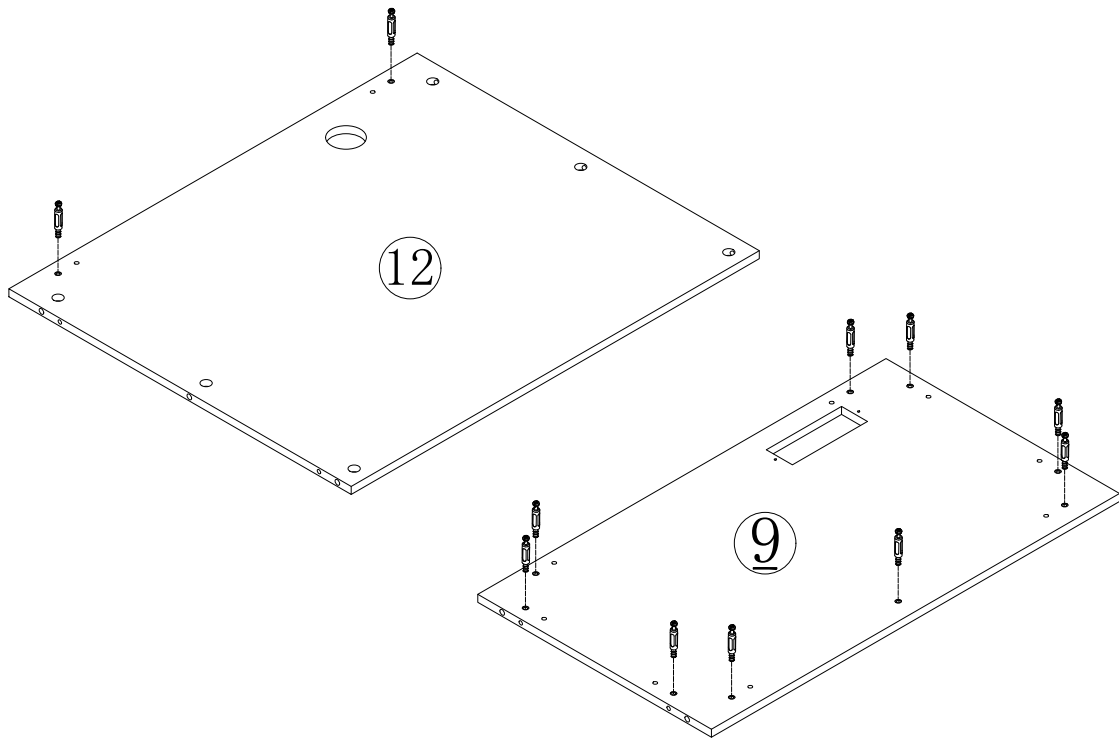

	Ax11pcs
---	---------

Assembly Steps (EN)

Step 5

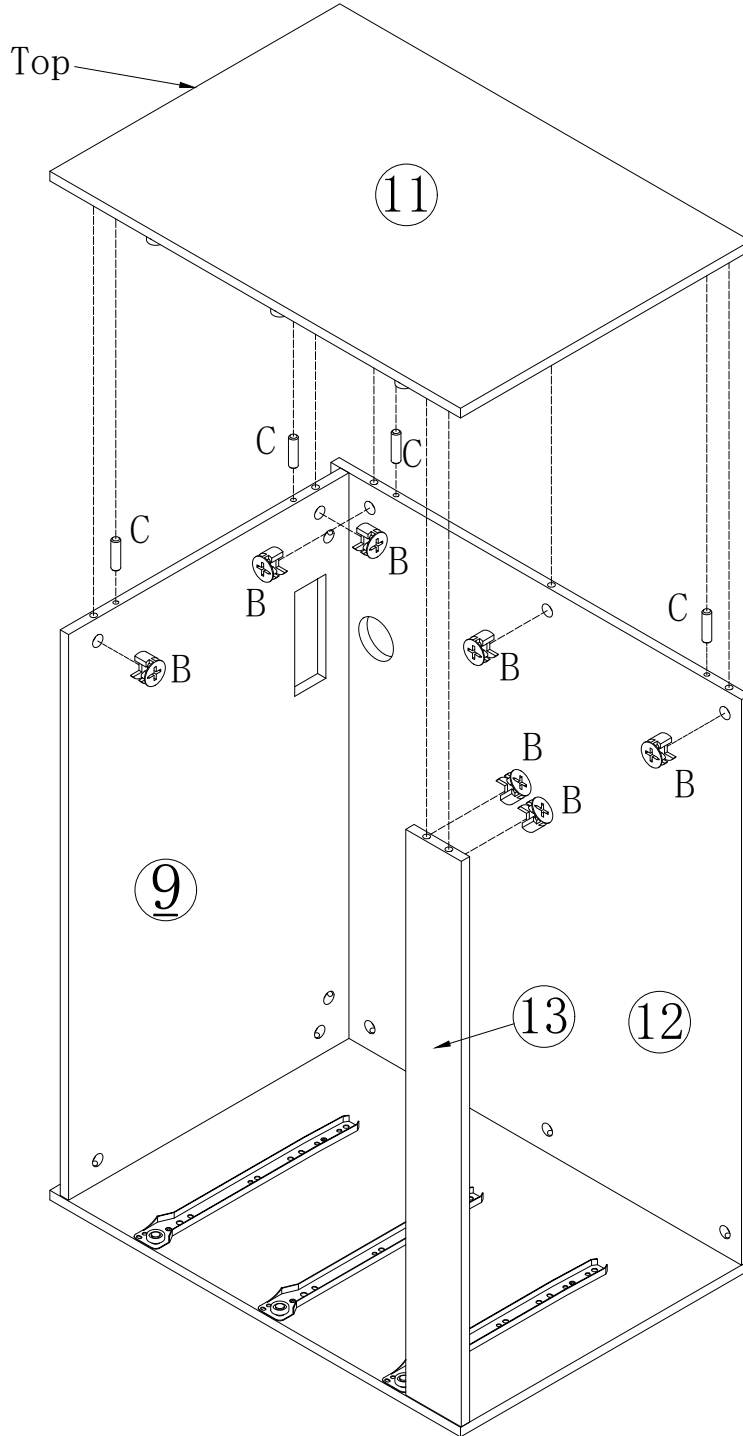

Cx4pcs



Bx7pcs

Assembly Steps (EN)

Step 6

When pulling out part (a), it is necessary to lift part (b) and pull out part (a) at the same time according to the operation of "Sample A", then the part (a) can be pulled out.

Push the (c) part to the (d) position, and the result is shown in Figure (e).

Step 7

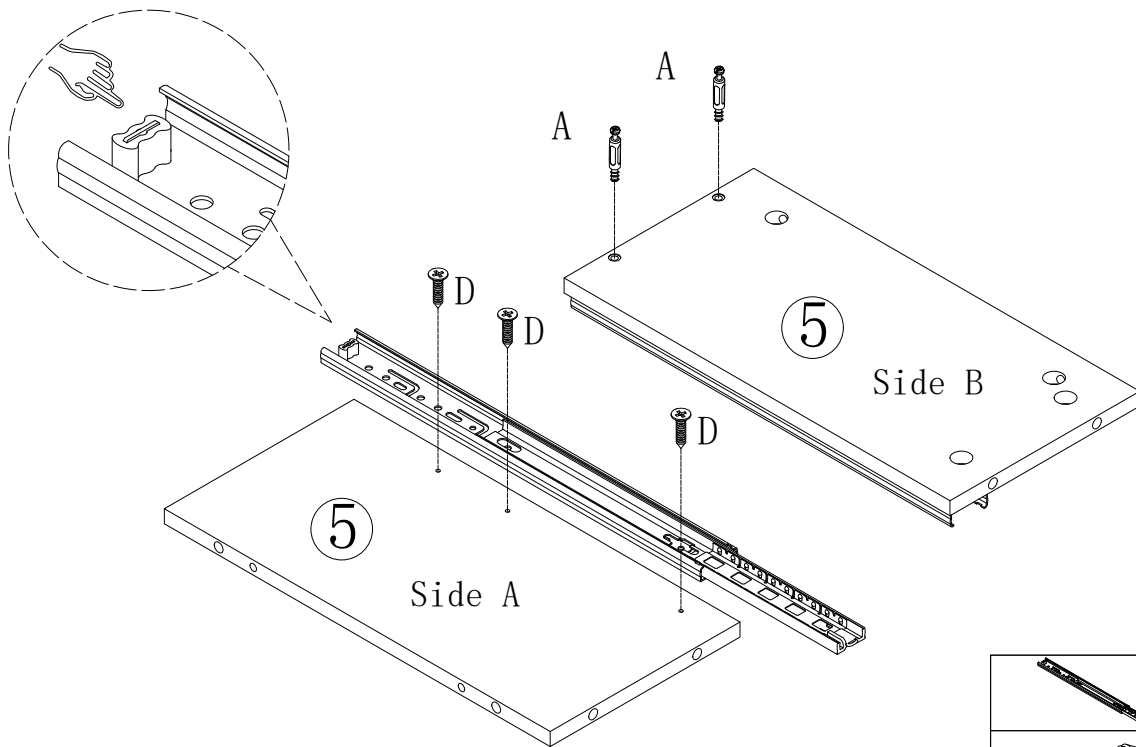



	M1x1pcs
	Dx3pcs
	Ax2pcs

Assembly Steps (EN)

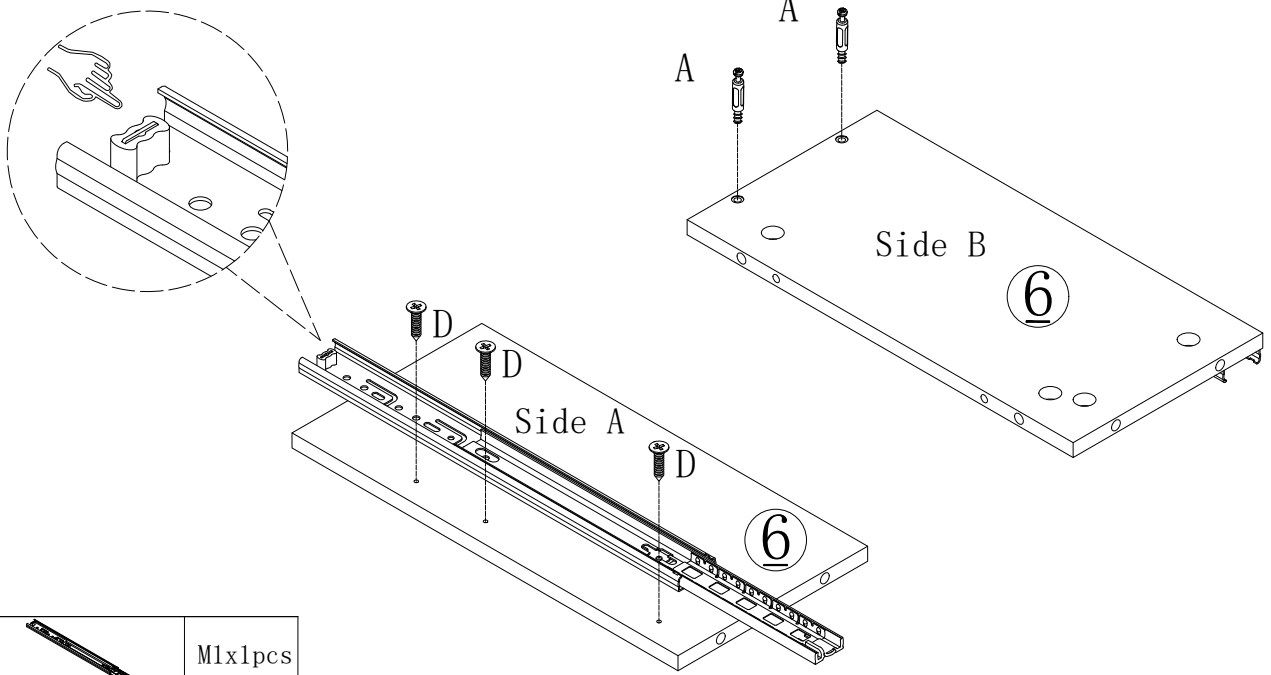
Step 8



	M1x1pcs
	Dx3pcs
	Ax2pcs

Step 9

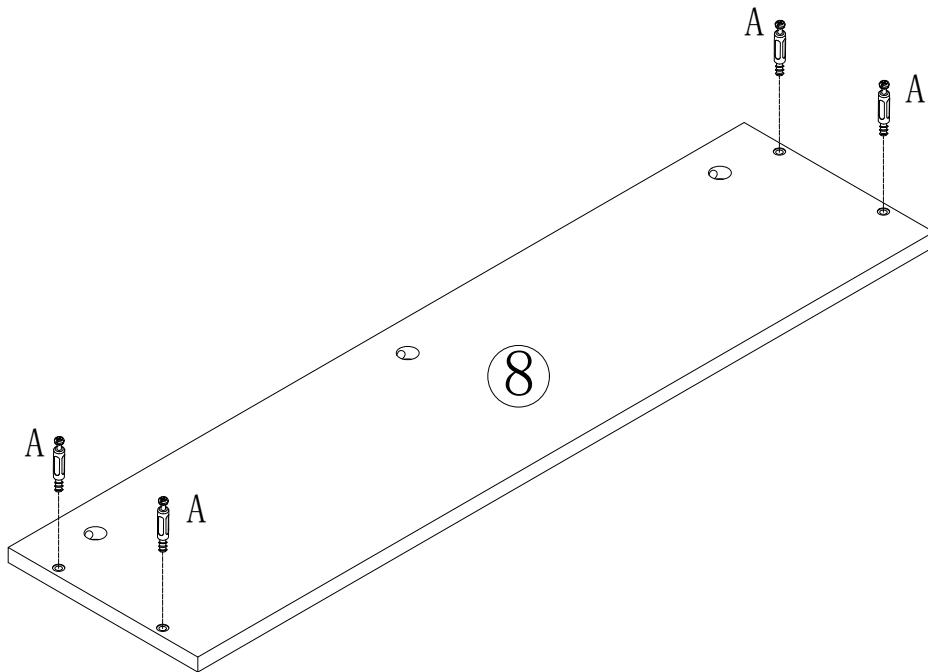

	Ax4pcs
---	--------

Assembly Steps (EN)

Step 10

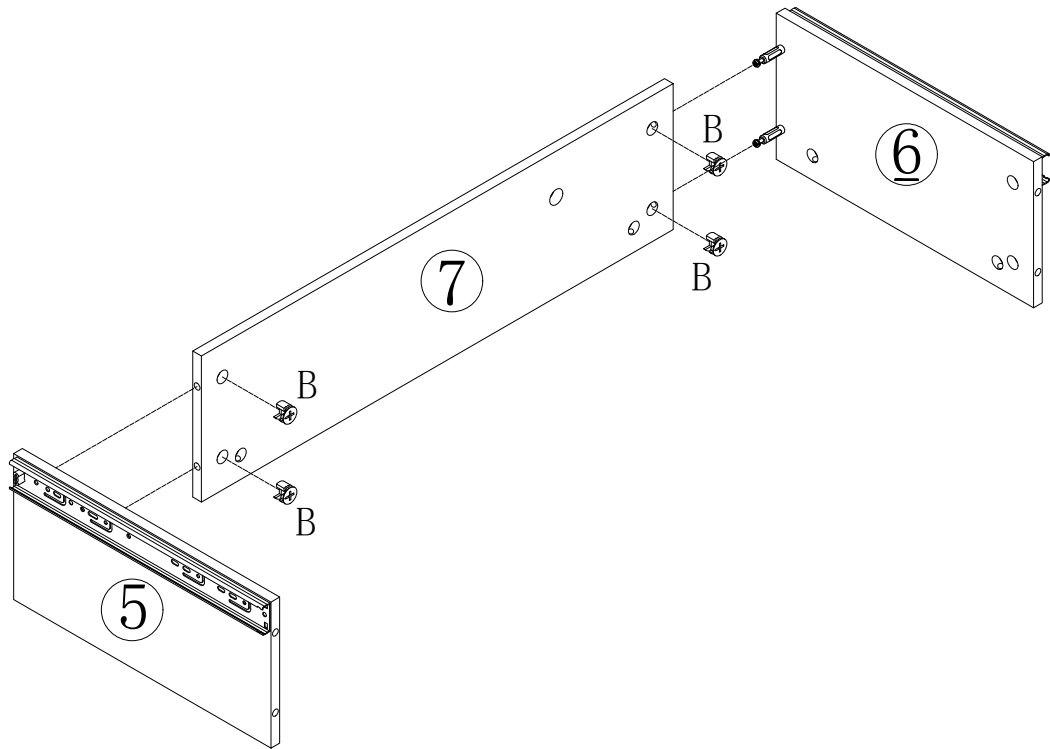

Bx4pcs

Step 11

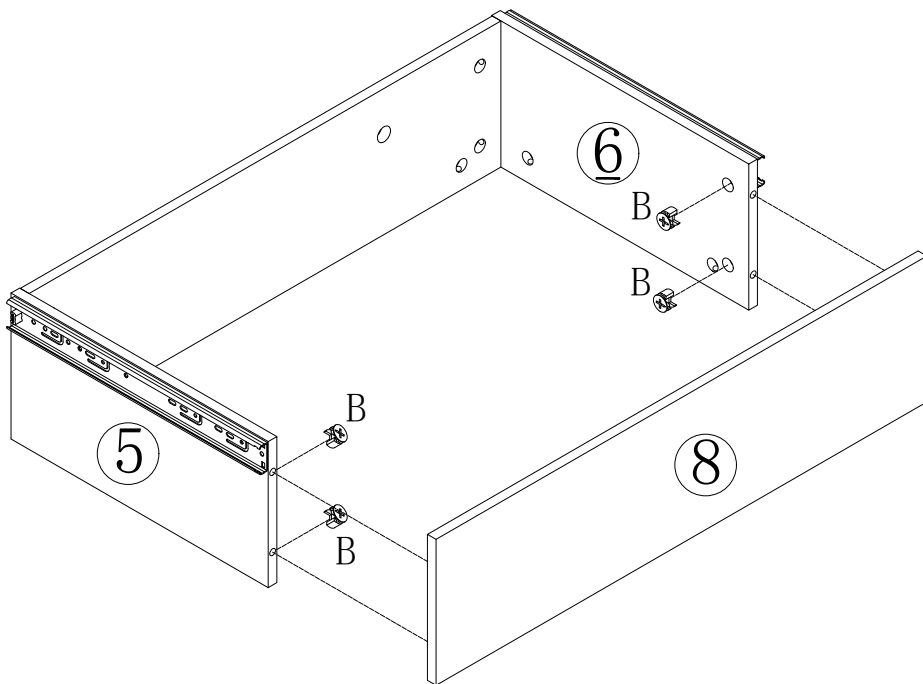

Ax4pcs

Assembly Steps (EN)

Step 12

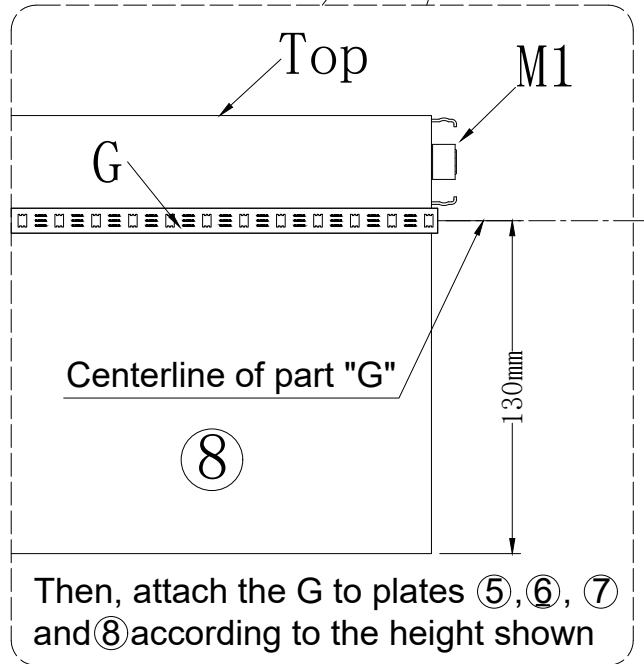
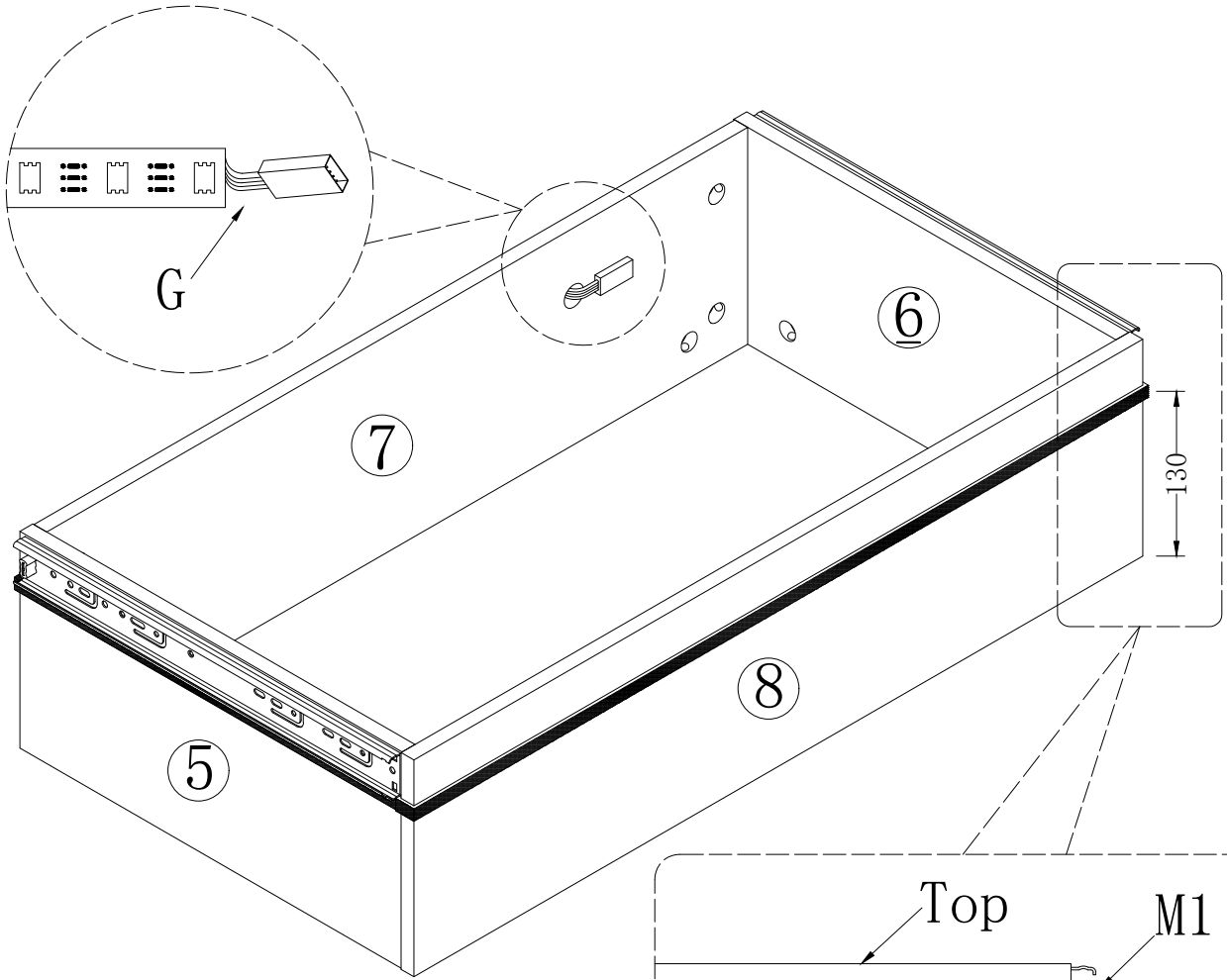

G

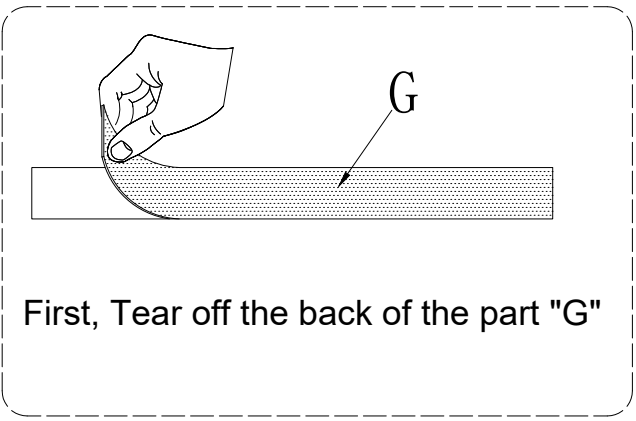



 Gx1pcs

Assembly Steps (EN)

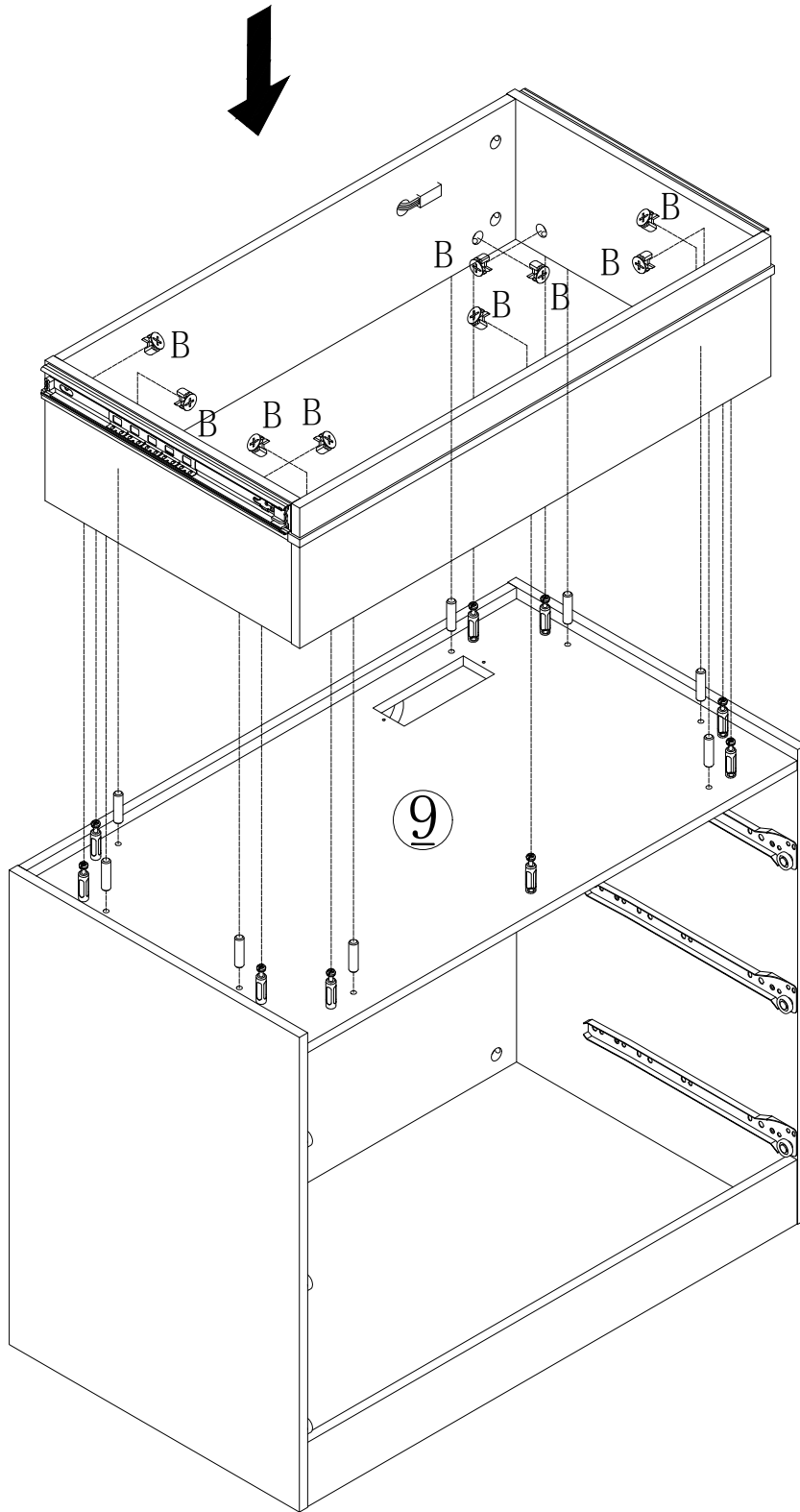
Step 13





	Cx8pcs
	Bx9pcs

Assembly Steps (EN)

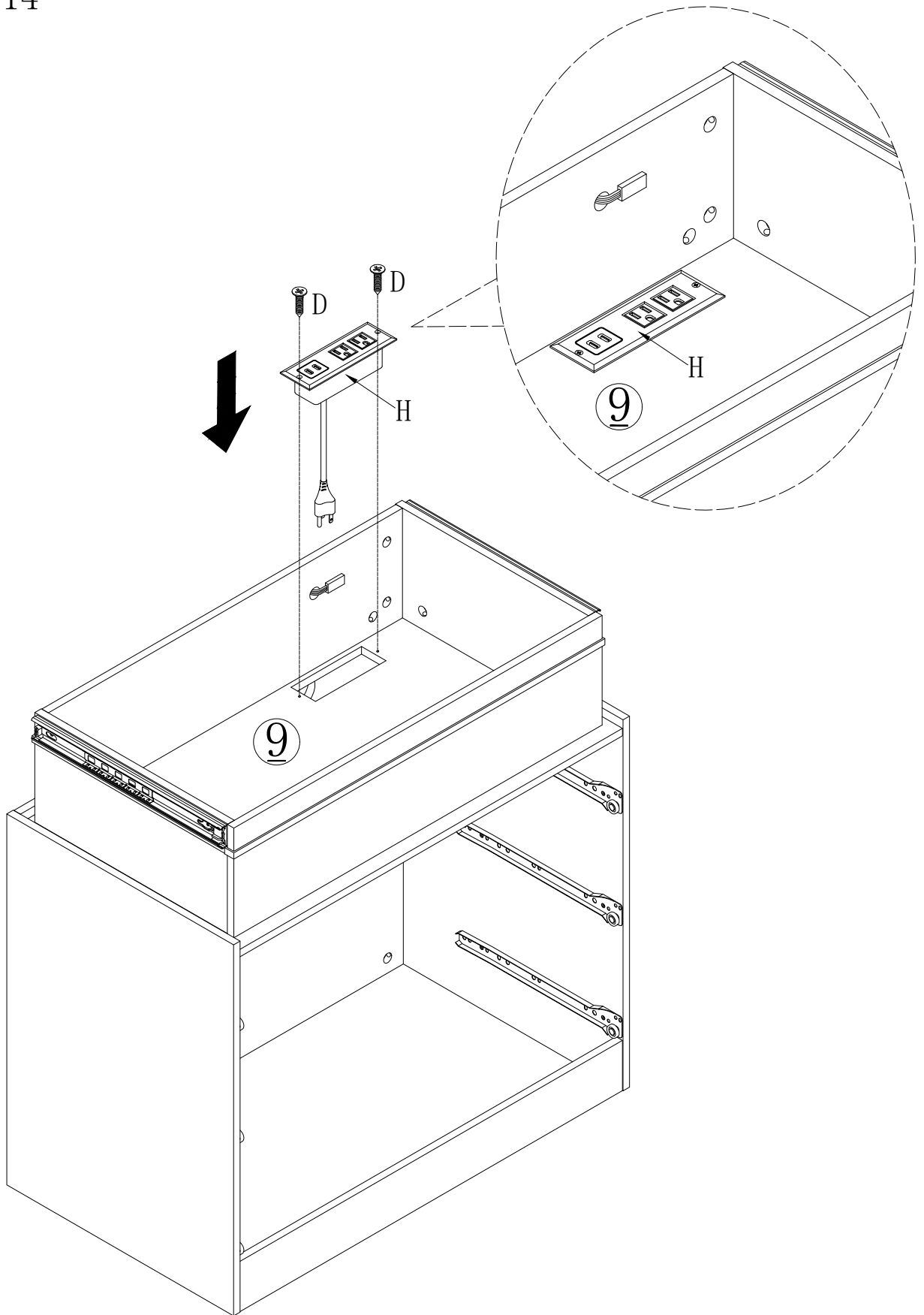
Step 14



	Dx2pcs
	Hx1pcs

Assembly Steps (EN)

Step 15

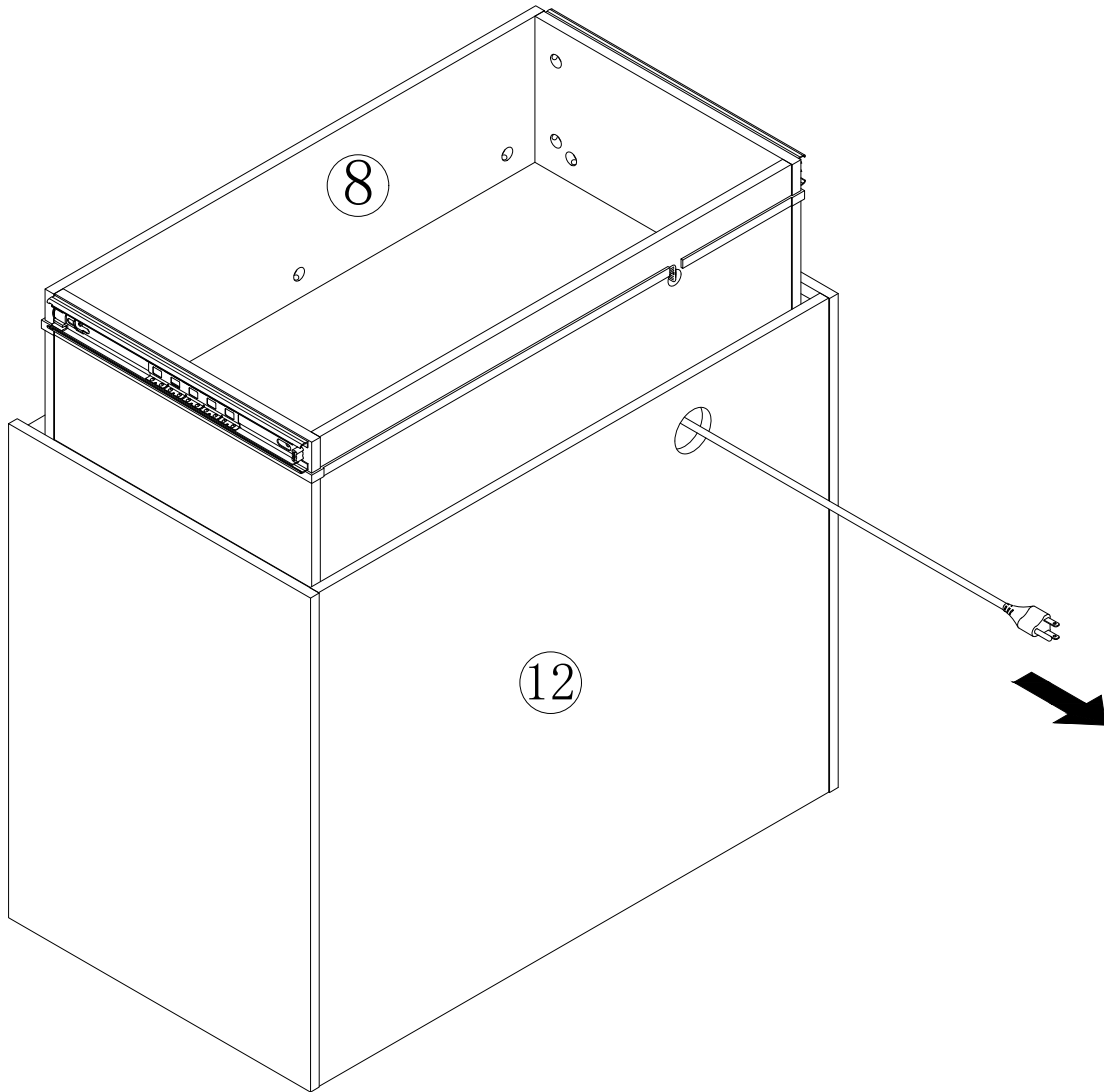

Assembly Steps (EN)

Step 16

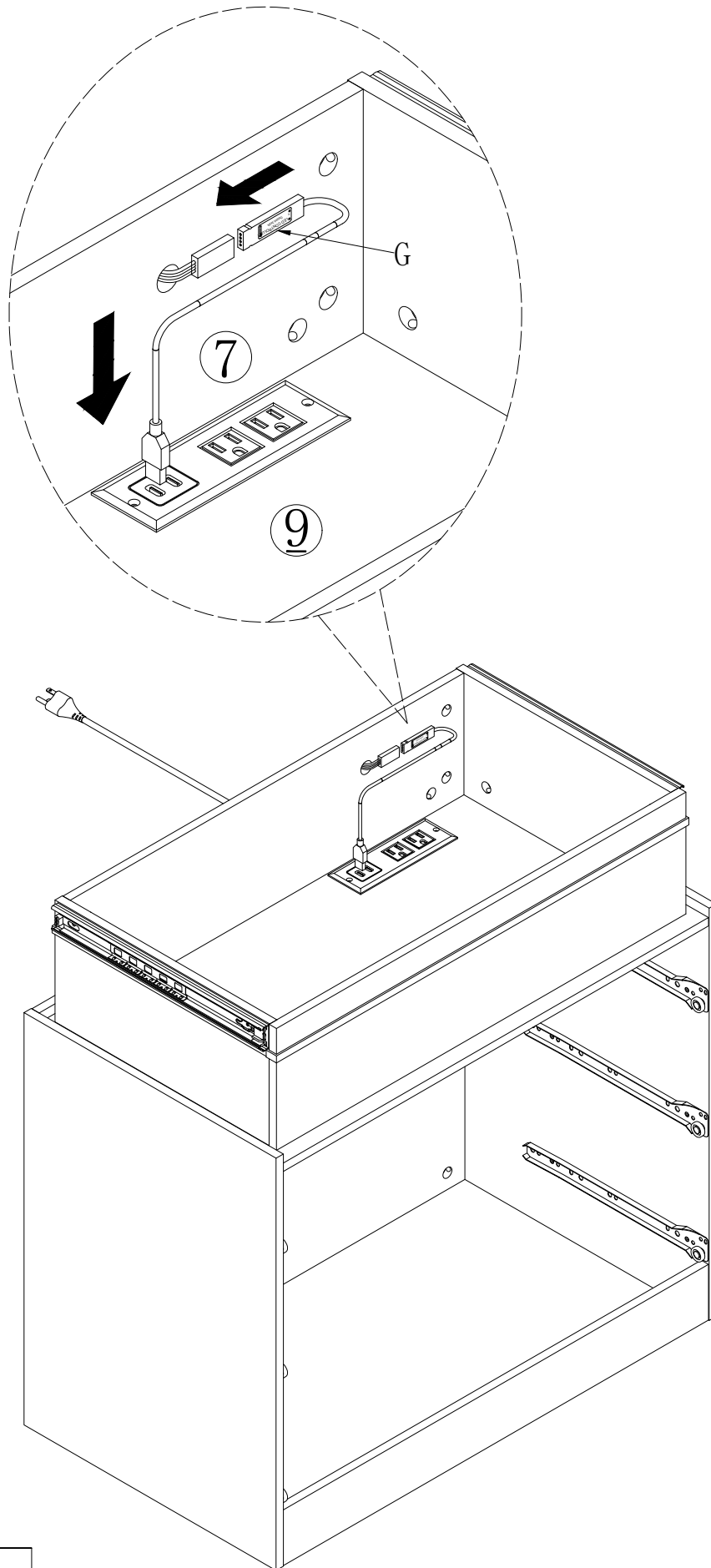

Gx1pcs

Assembly Steps (EN)

Step 17

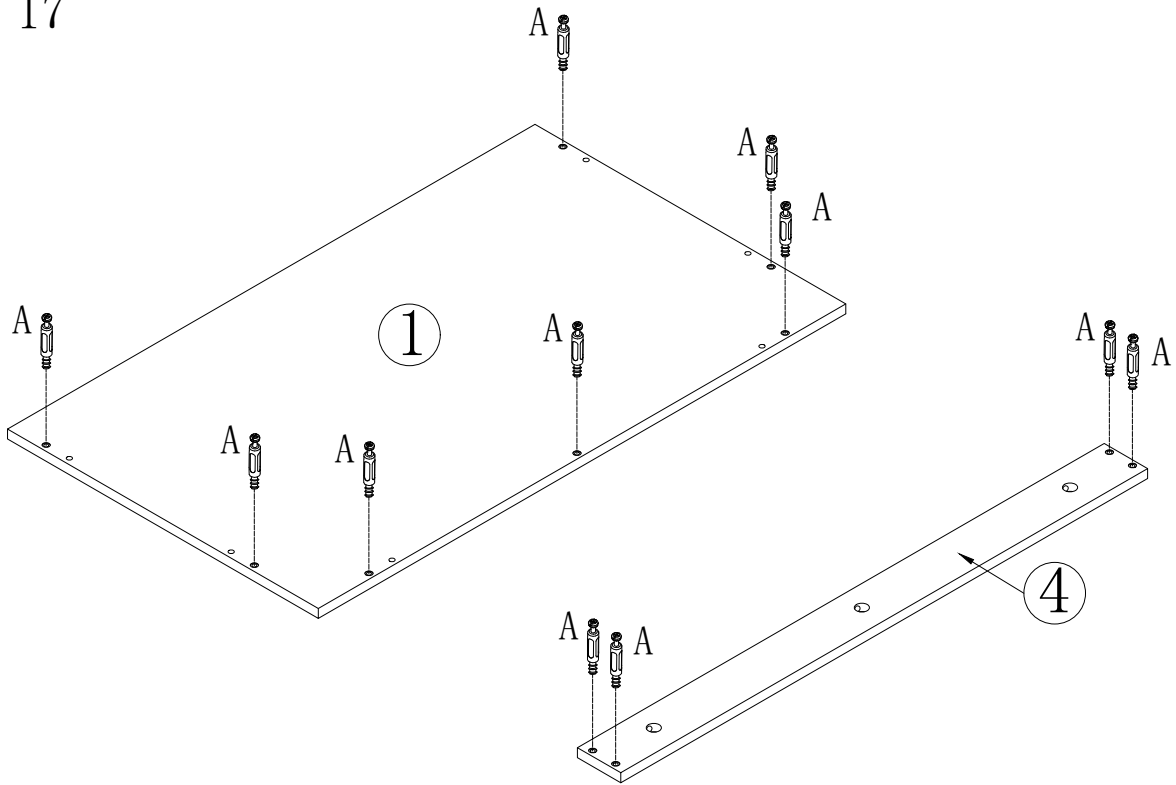

Ax11pcs

Step 18

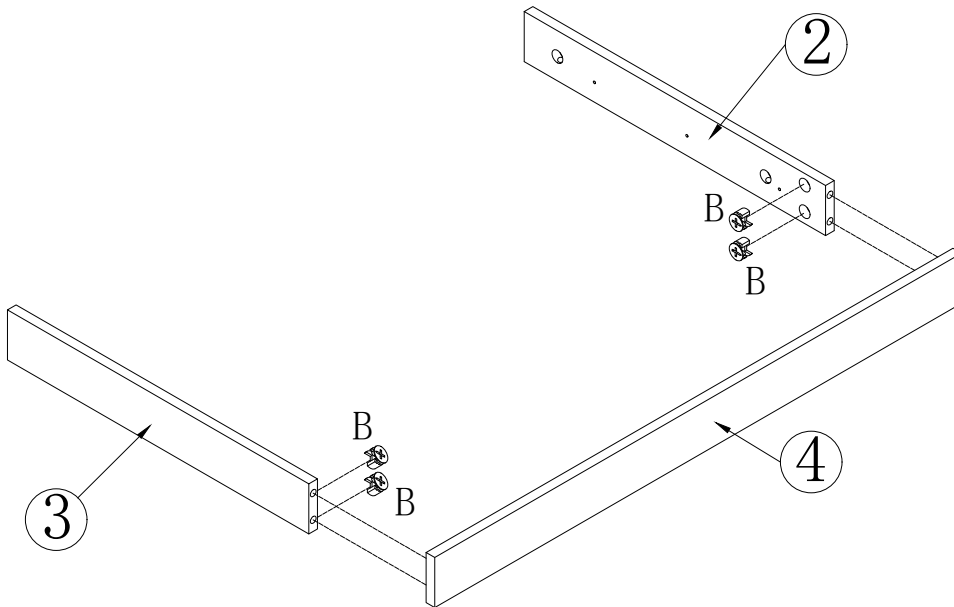



Ax4pcs

Assembly Steps (EN)

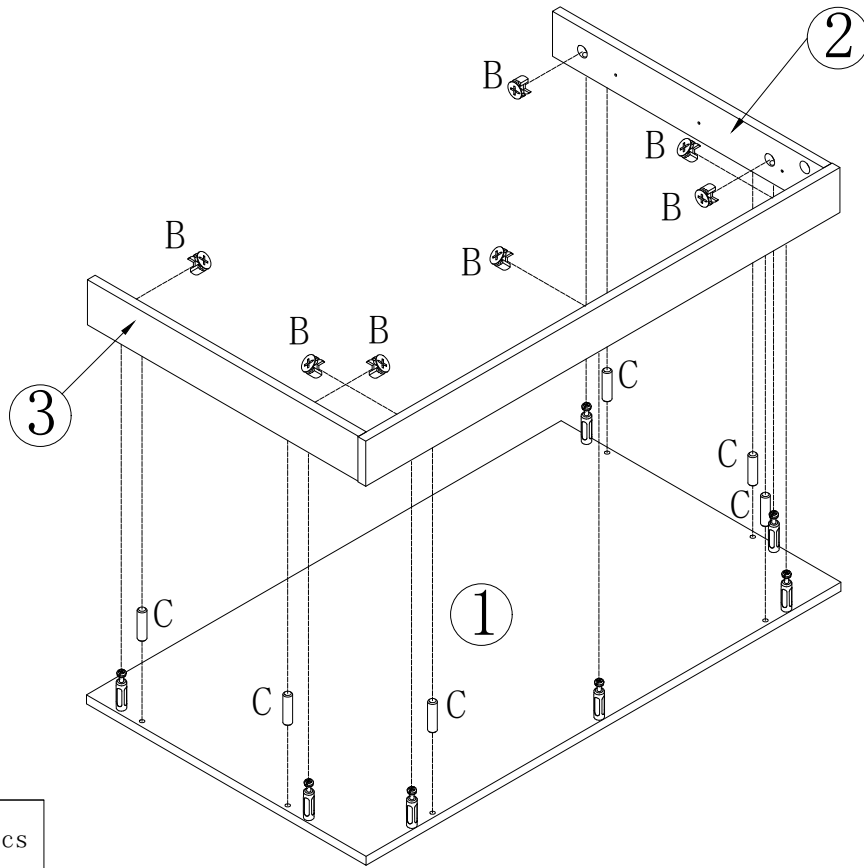

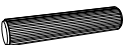
Step 19

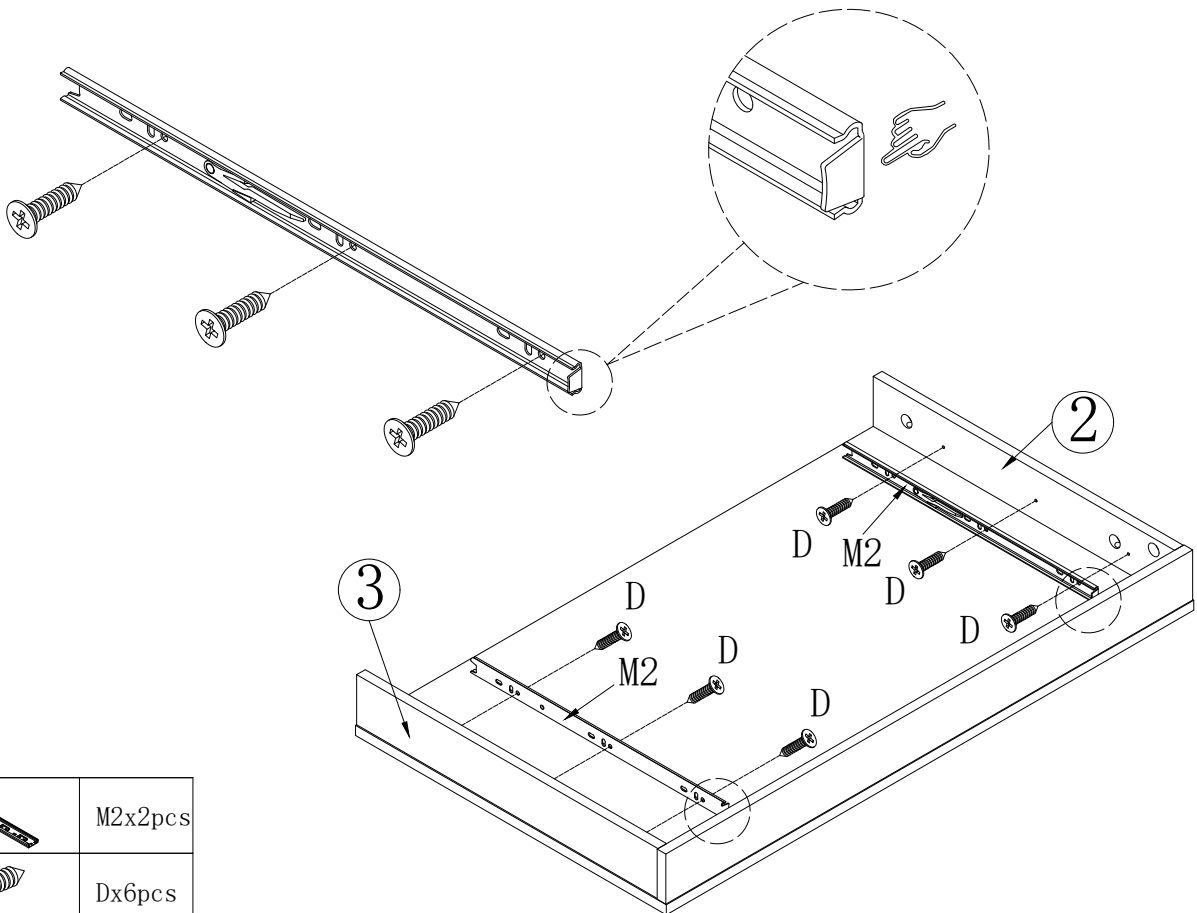

	Cx6pcs
	Bx7pcs

Step 20



	M2x2pcs
	Dx6pcs

Assembly Steps (EN)

Step 21

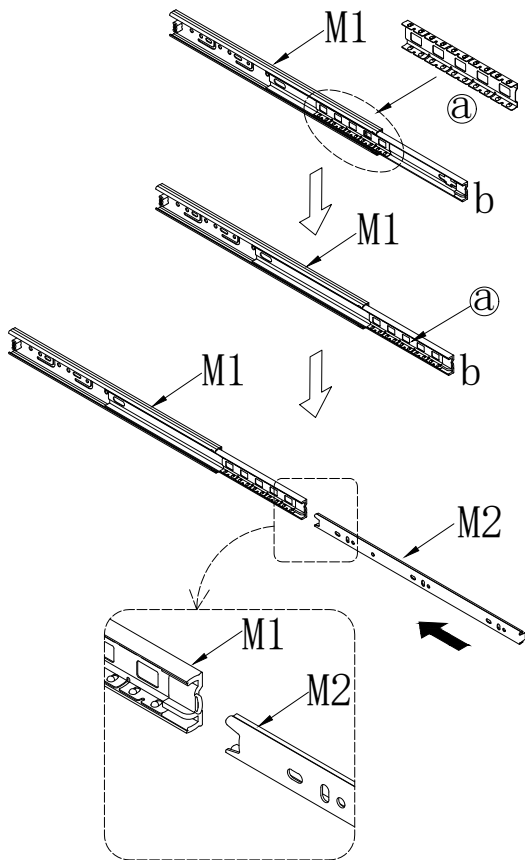
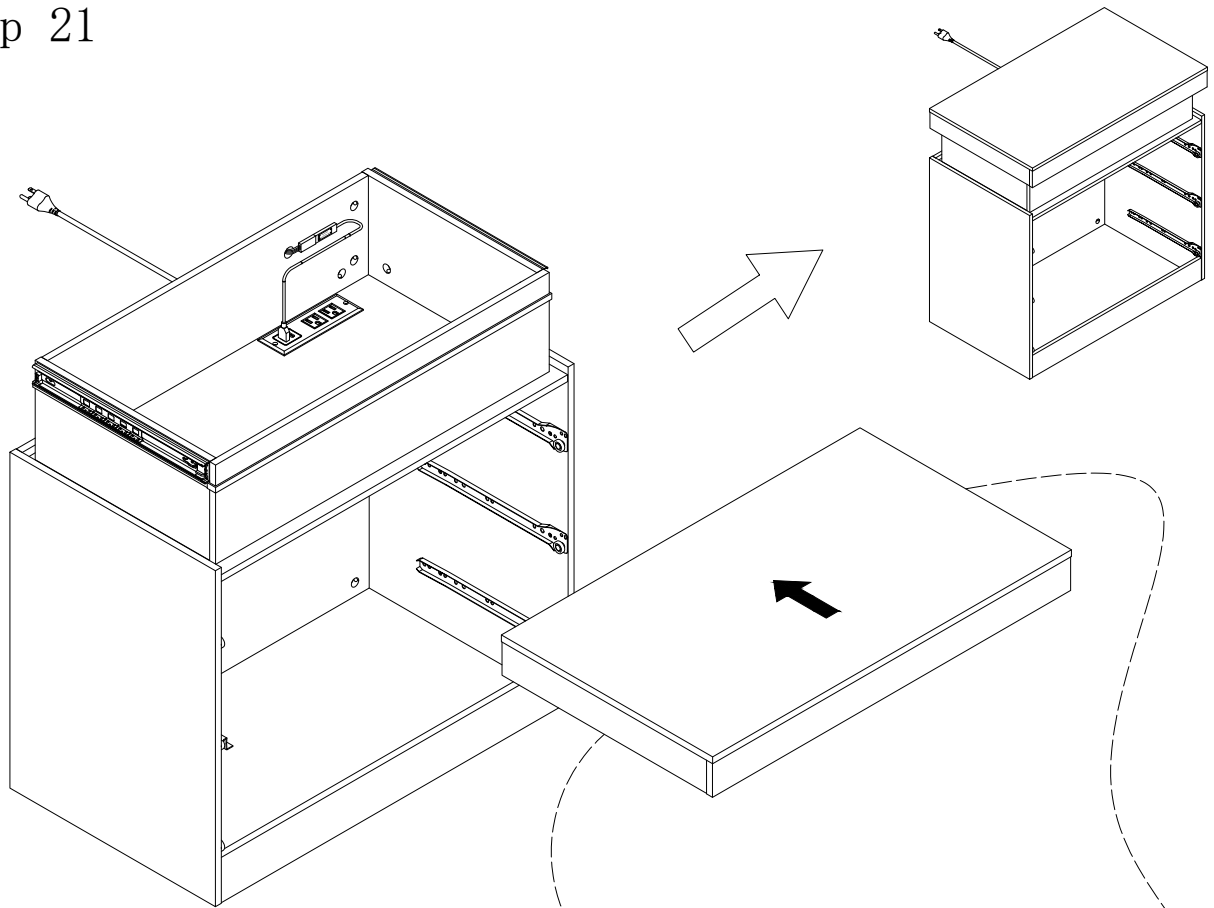

Sample A

Lift up

Sample B

Push down

Sample C

- (1)、When putting the drawer into the cabinet, first, push the "a" part of M1 to "b", then point the end of M2 at "b", finally, put the drawer into the cabinet as shown in "Sample A";
- (2)、When removing the drawer, press "Sample B" and "Sample C" as shown, lift the left side of the drawer © part, press the right side of the drawer © part, and pull out the drawer. (The operation of "Sample B" and "Sample C" shall be carried out simultaneously)

Assembly Steps (EN)

Step 22

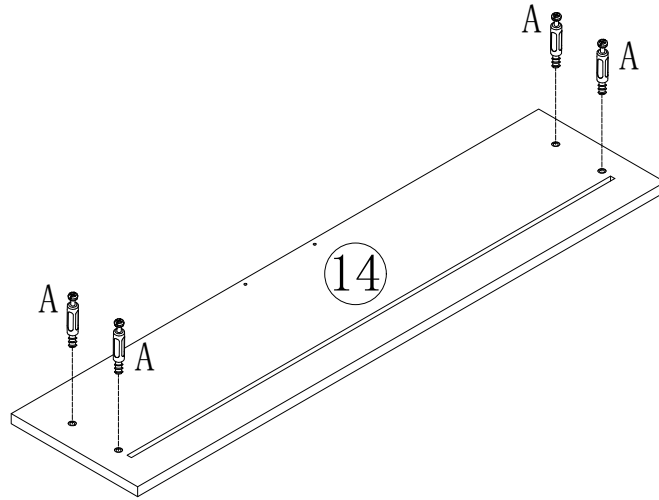

x3



Ax12pcs

Step 23

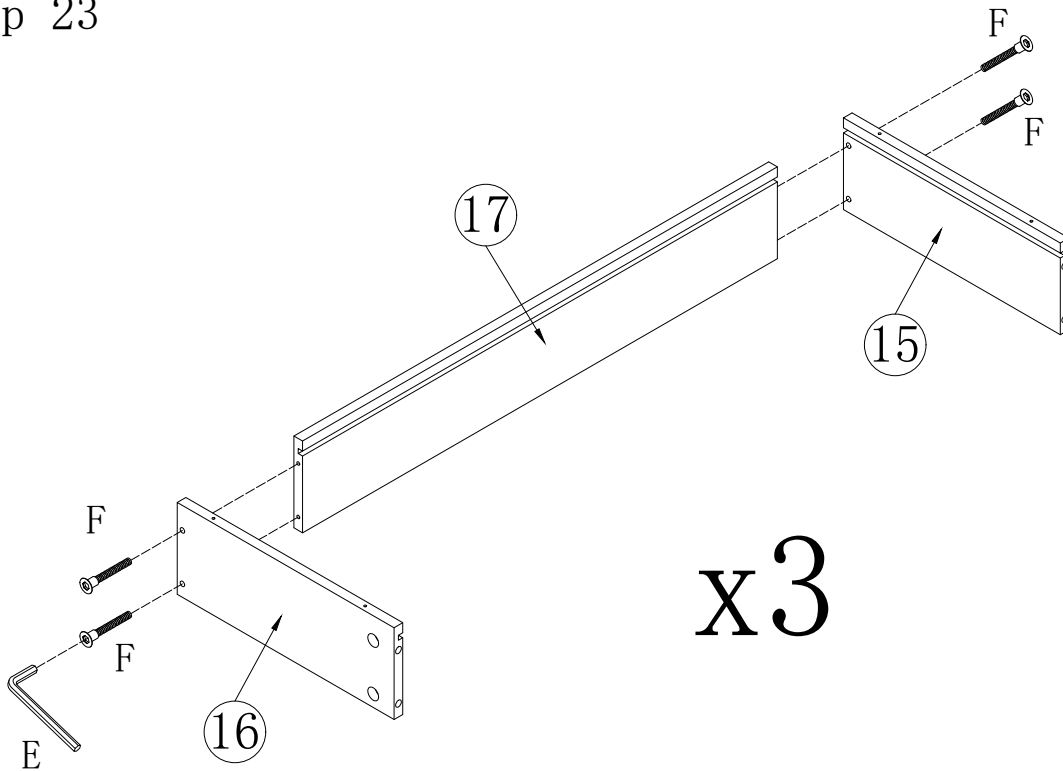

x3

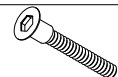

Fx12pcs



Ex1pcs

Assembly Steps (EN)

Step 24

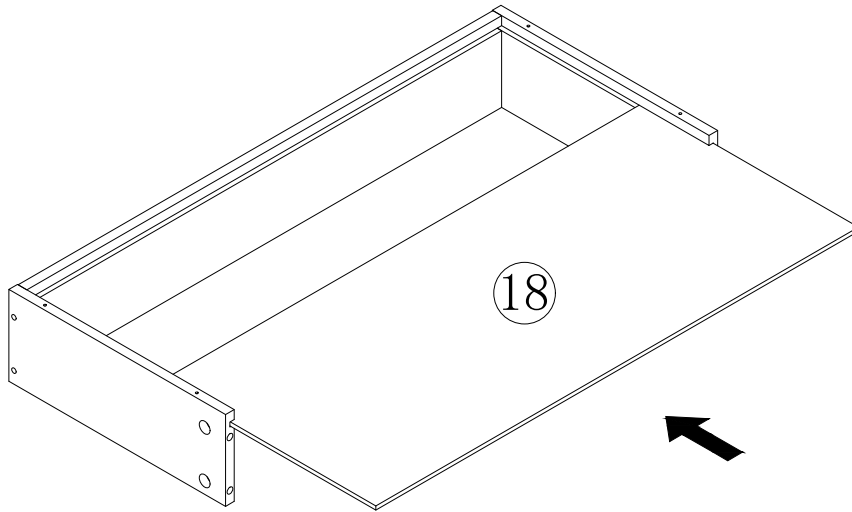

x3

Step 25

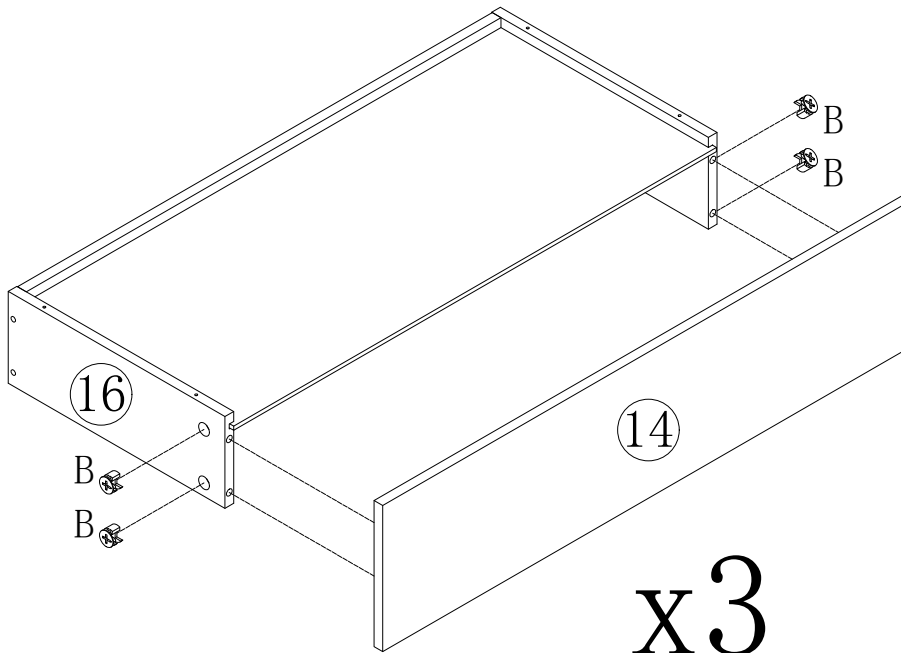

x3



Bx12pcs

Assembly Steps (EN)

Step 26

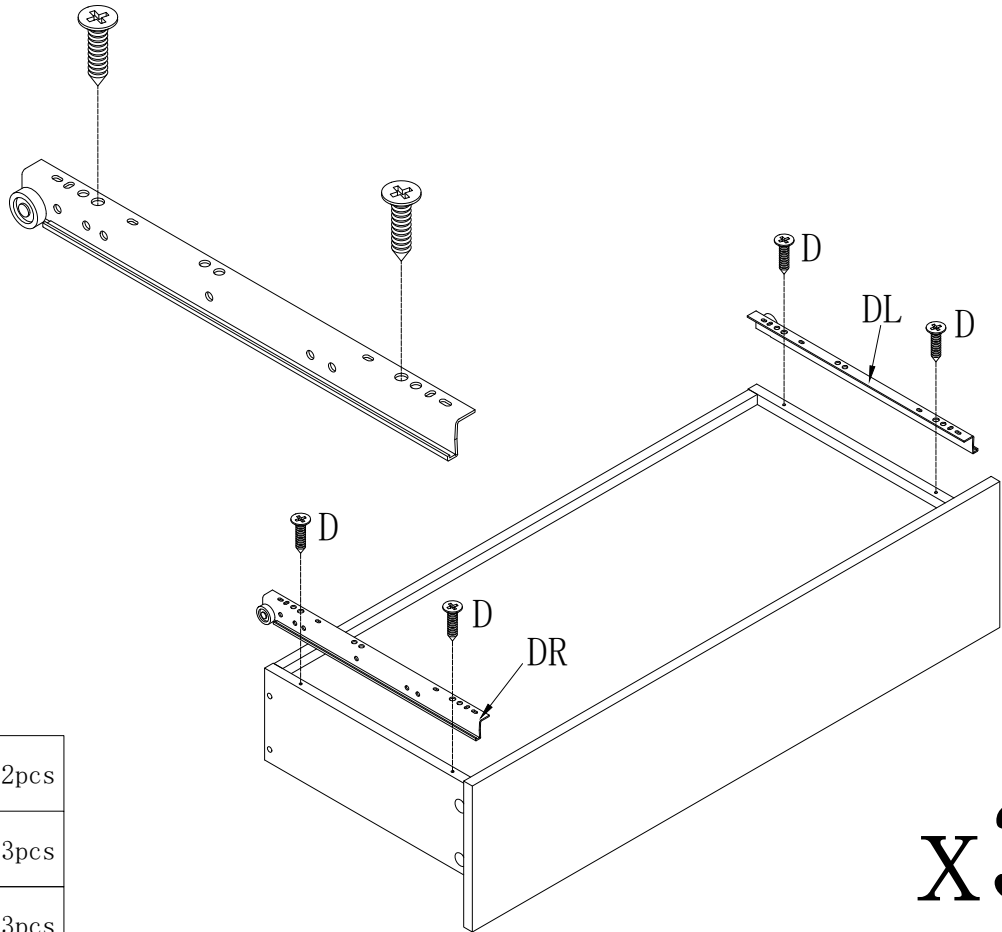

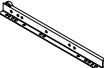
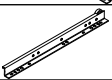
	Dx12pcs
	DRx3pcs
	DLx3pcs

x3

Step 27

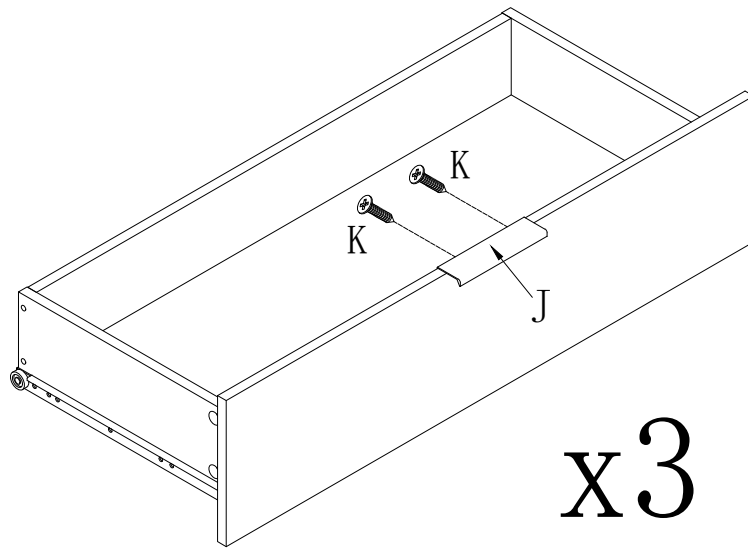

x3

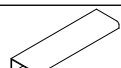
	Kx6pcs
	Jx3pcs

Assembly Steps (EN)

Step 28

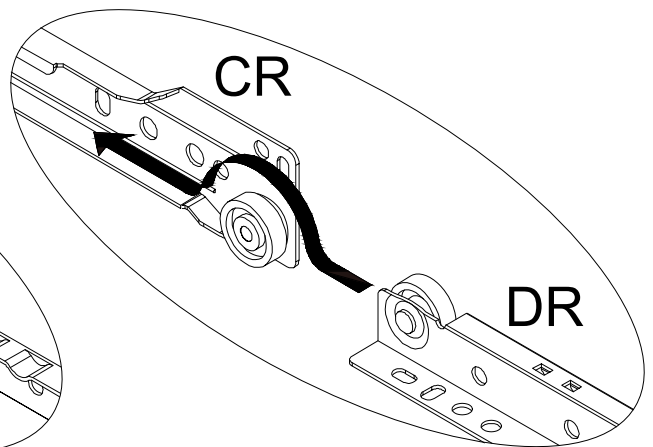
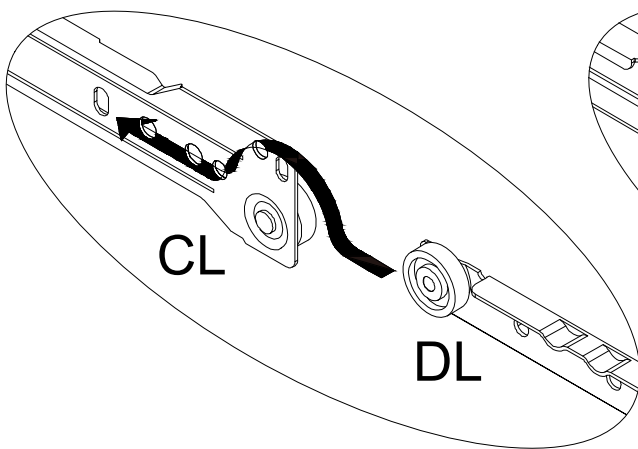
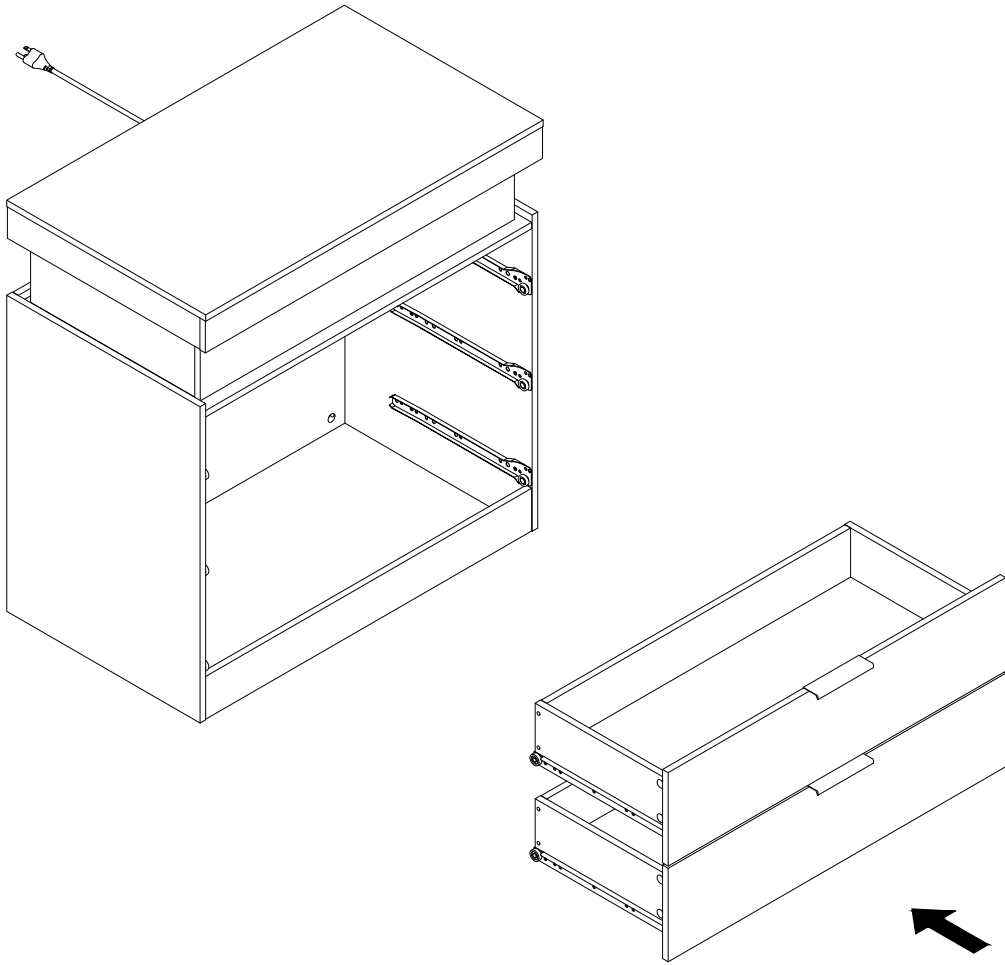

Assembly Steps (EN)

Step 29

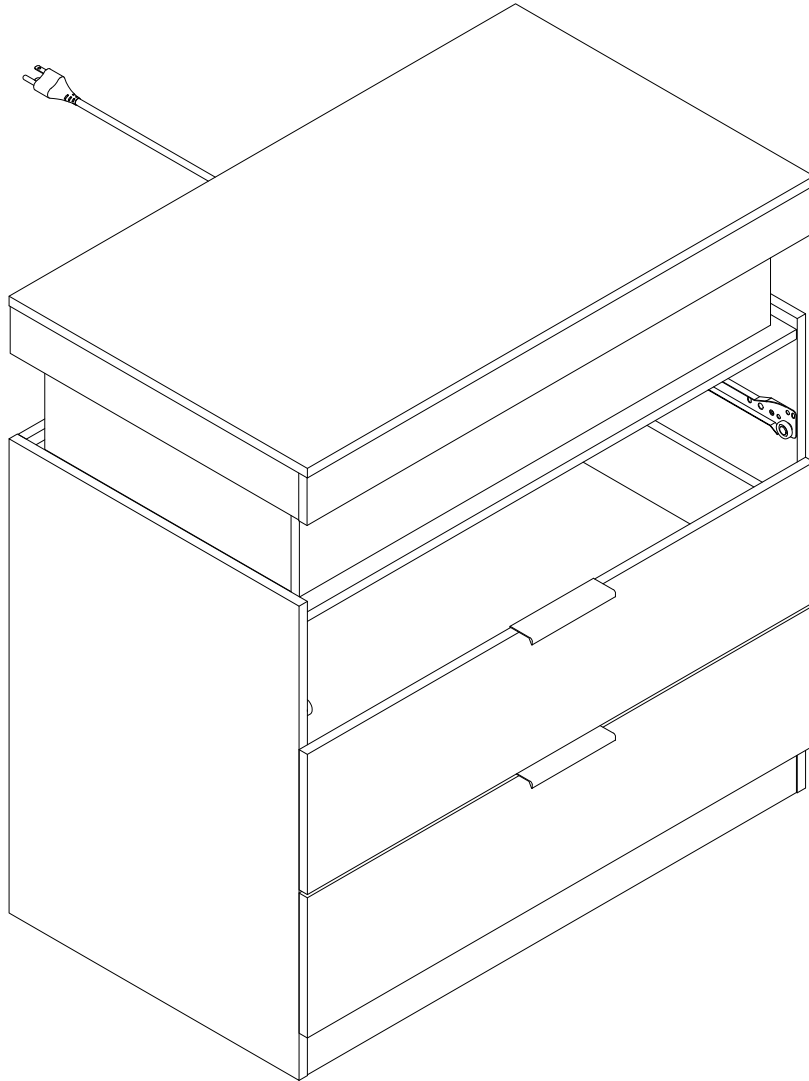

Assembly Steps (EN)

Step 30

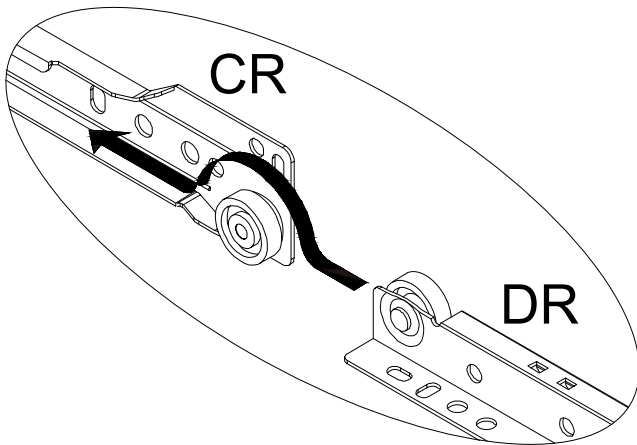
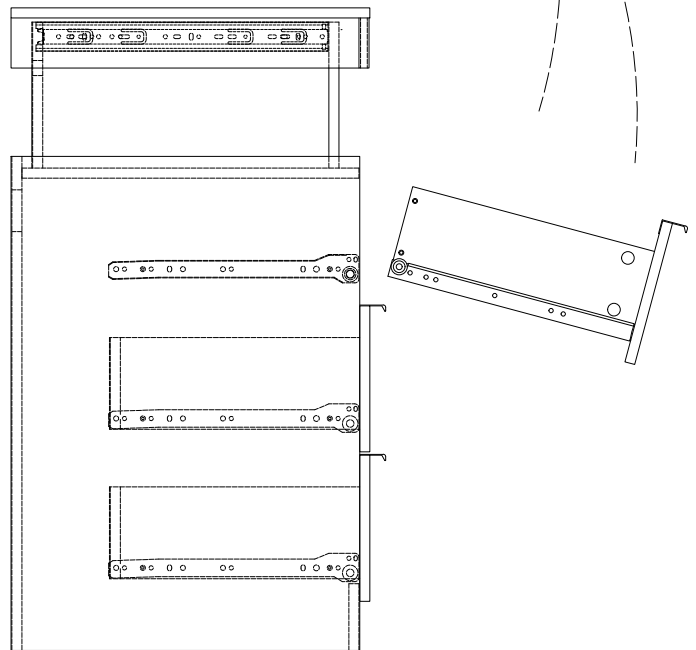
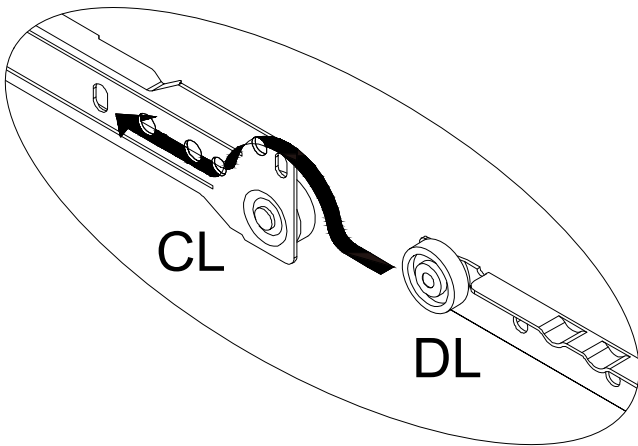
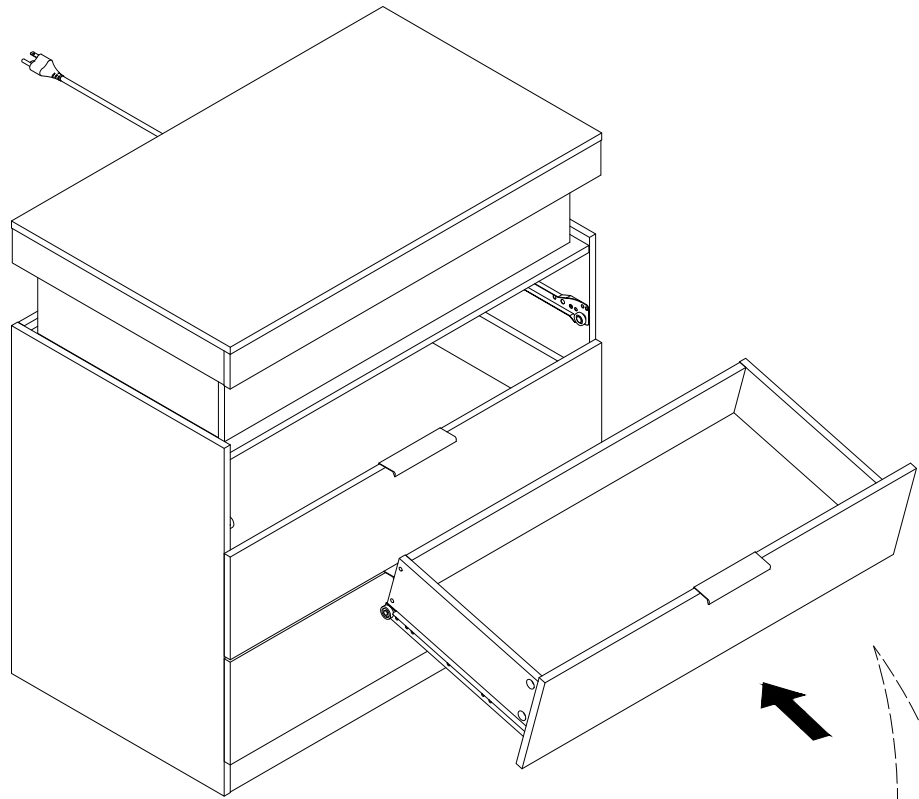

Assembly Steps (EN)

Step 31

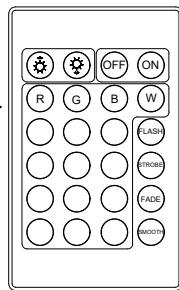
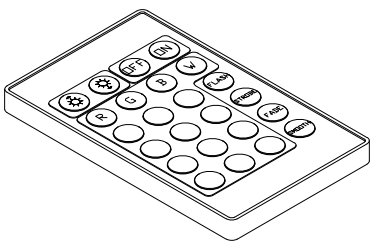
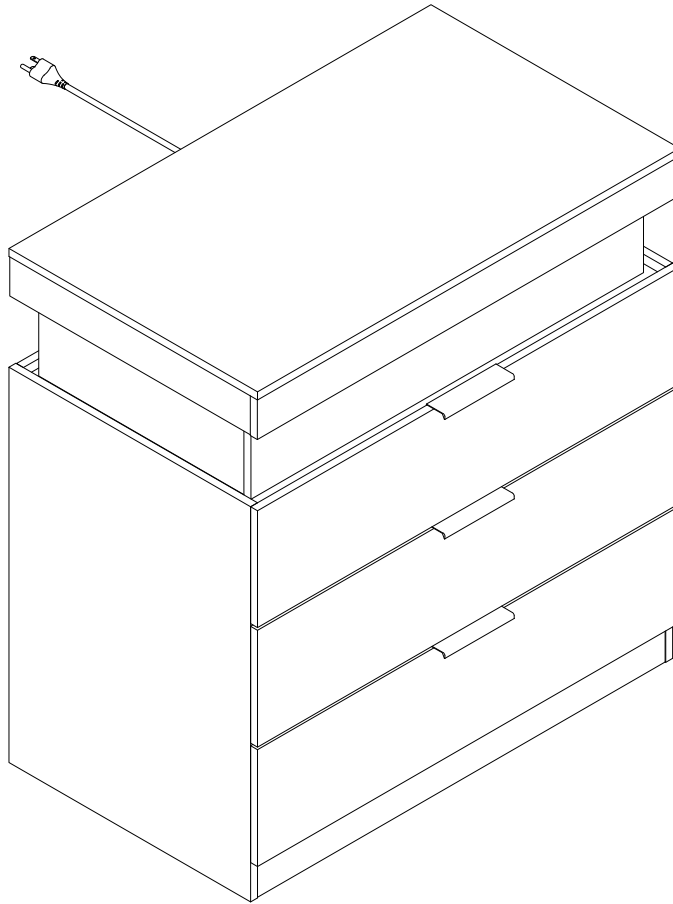

- ⚙️ : Brightness increase button
- ⚙️+ : Lower brightness button
- ⏻ : Turn off the power
- ⏻ : Turn on the power
- R : Red Light
- G : Green light
- B : Blue Light
- W : White Light
- FLASH : Flash model
- STROBE : Strobe model
- FADE : Fade model
- SMOOTH : Smooth model



Gx1pcs

Assembly Steps (EN)

Step 32

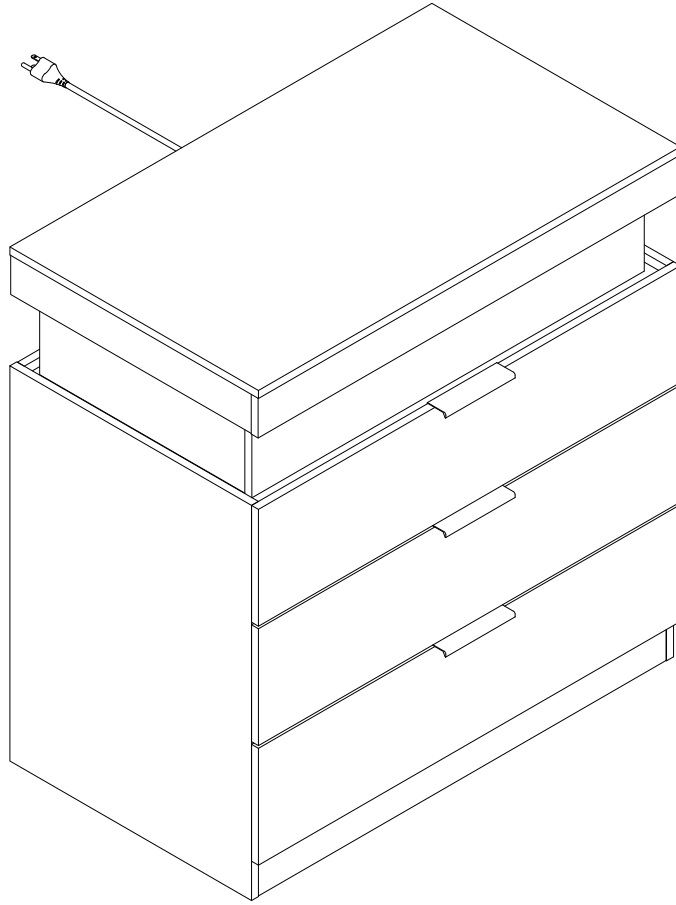

Final