

# ASSEMBLY INSTRUCTIONS

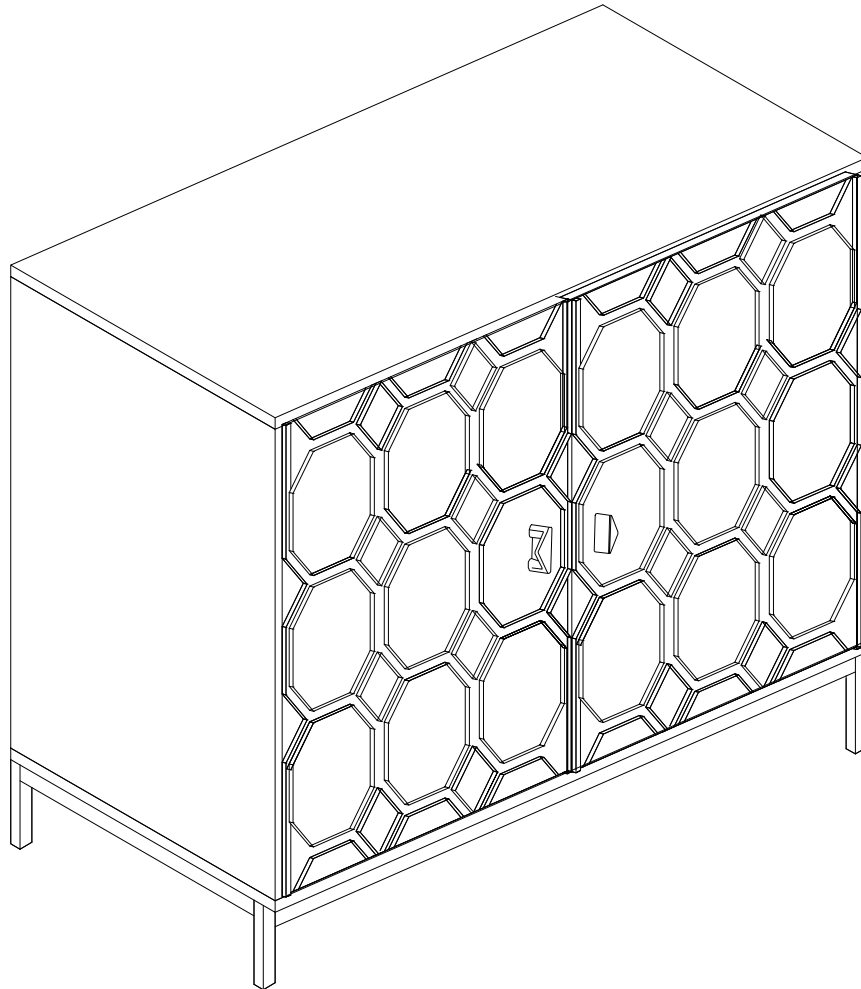

**WARNING:**

**TIPPING HAZARD.** This cabinet can tip over if not secured, causing serious injury or death. Always attach to the wall using the safety wall strap (Part M) provided. Never allow children to climb on doors, shelves, or use the product as a step.

U.S. Customer Service: (951) 213-4742 (Mon-Fri, 9AM-5PM PST)  
Email: [contactus24service@gmail.com](mailto:contactus24service@gmail.com)

MADE IN MALAYSIA

# ASSEMBLY INSTRUCTIONS

## Part list:

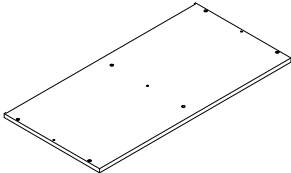
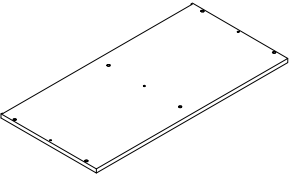
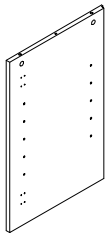
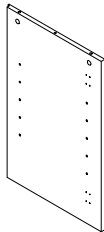
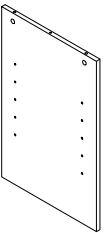
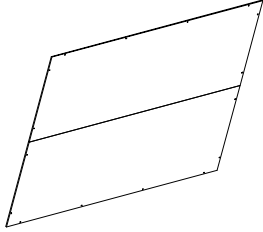



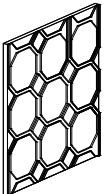
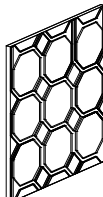
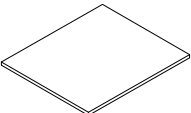
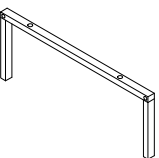
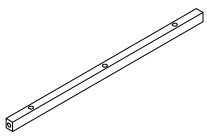

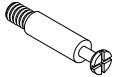

ITEM	DESCRIPTION	PART	QTY
1	Top panel		1
2	Bottom panel		1
3	Left side panel		1
4	Right side panel		1
5	Middle side plate		1
6	Back panel		1

## Part list:









ITEM	DESCRIPTION	PART	QTY
7	Left door		1
8	Right door		1
9	Adjustable plate short		2
10	Leg		2
11	Leg		2

## ASSEMBLY INSTRUCTIONS

## Hardware List:

ITEM	DESCRIPTION	PART	QTY
A	Camlock bolt		6
B	Camlock		6
C	Wooden dowel	 Φ0.31*1.18"	6
D	Bolt	 Φ0.31*1.18"	10
E	Allen wrench		1
F	Bolt	 Φ0.31*1.57"	4
G	Handle		2
H	Machine screw	 Φ0.15*0.7"	4
I	Door hing (big bend)		4

## Hardware List:

ITEM	DESCRIPTION	PART	QTY
J	Round head screw	 Φ0.15*0.47"	24
K	Back screw	 Φ0.11*0.55"	16
L	Shelf support		8
M	Safety wall strap		2
N	Plastic anchor		2
O	Mounting screw	 Φ0.15*1.57"	2
P	Washer		2
Q	Mounting screw	 Φ0.15*1.37"	6

## ASSEMBLY INSTRUCTIONS

- \* Required screwdriver & mallet, not included.
- \* Before discarding packing materials, please check to make sure that all parts and hardware is present.
- \* Two people needed for assembly.
- \* Please follow the instructions closely; Do not over-tighten screws or bolts unless specified.
- \* After a few days from initial assembly, the product may adjust to the environment. Please retighten the hardware.

### Guideline For Assembling of Cam Lock (A & B)

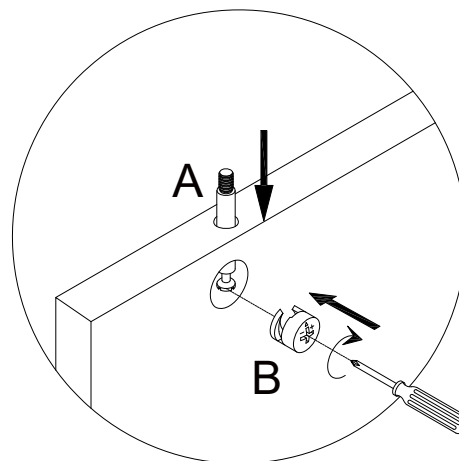
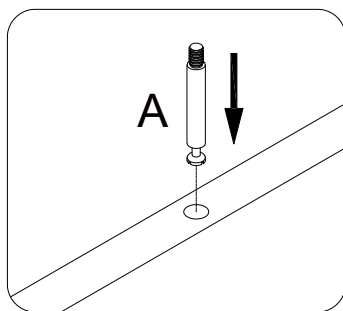





Screw camlock bolt (A) to wood part.

Do not assemble camlock (B) unless instructed.

To assemble camlock (B), ensure long side of the + is facing the bolt (A) before inserting into hole.

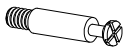
# ASSEMBLY INSTRUCTIONS

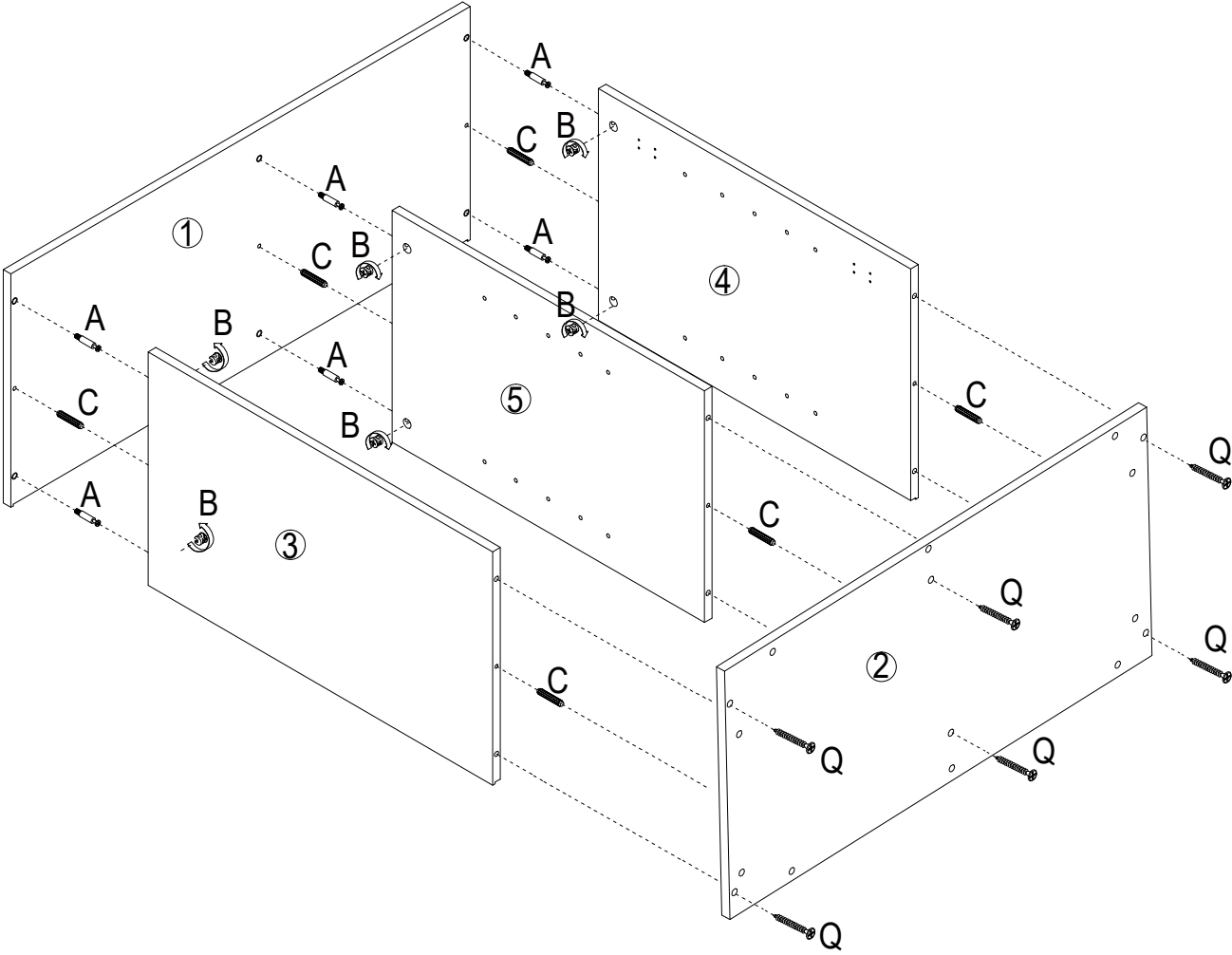

## STEP 1

A:		6PCS
B:		6PCS
C:		6PCS
Q:		6PCS



# ASSEMBLY INSTRUCTIONS

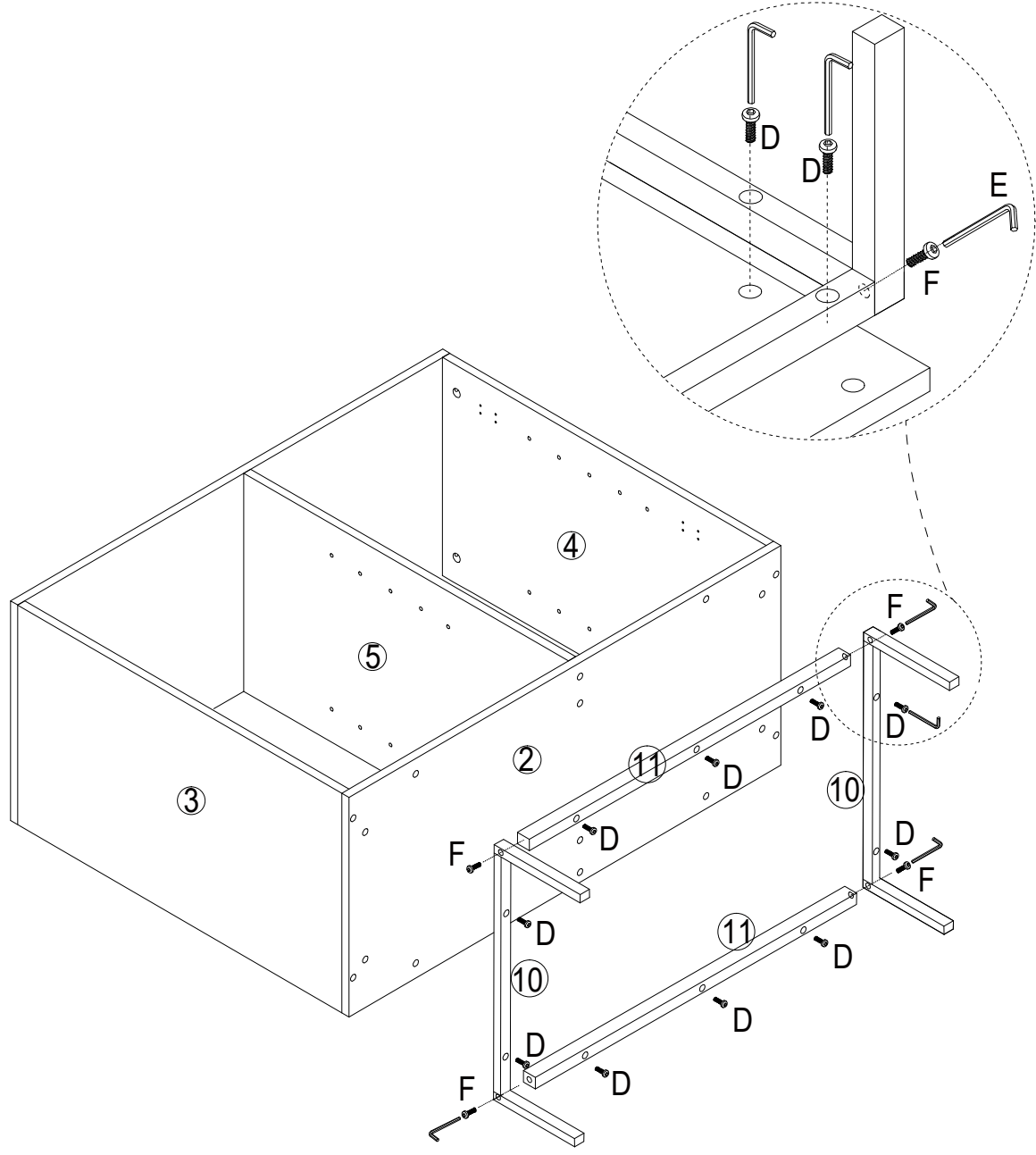

## STEP 2

- D:  10PCS
- E:  1PC
- F:  4PCS





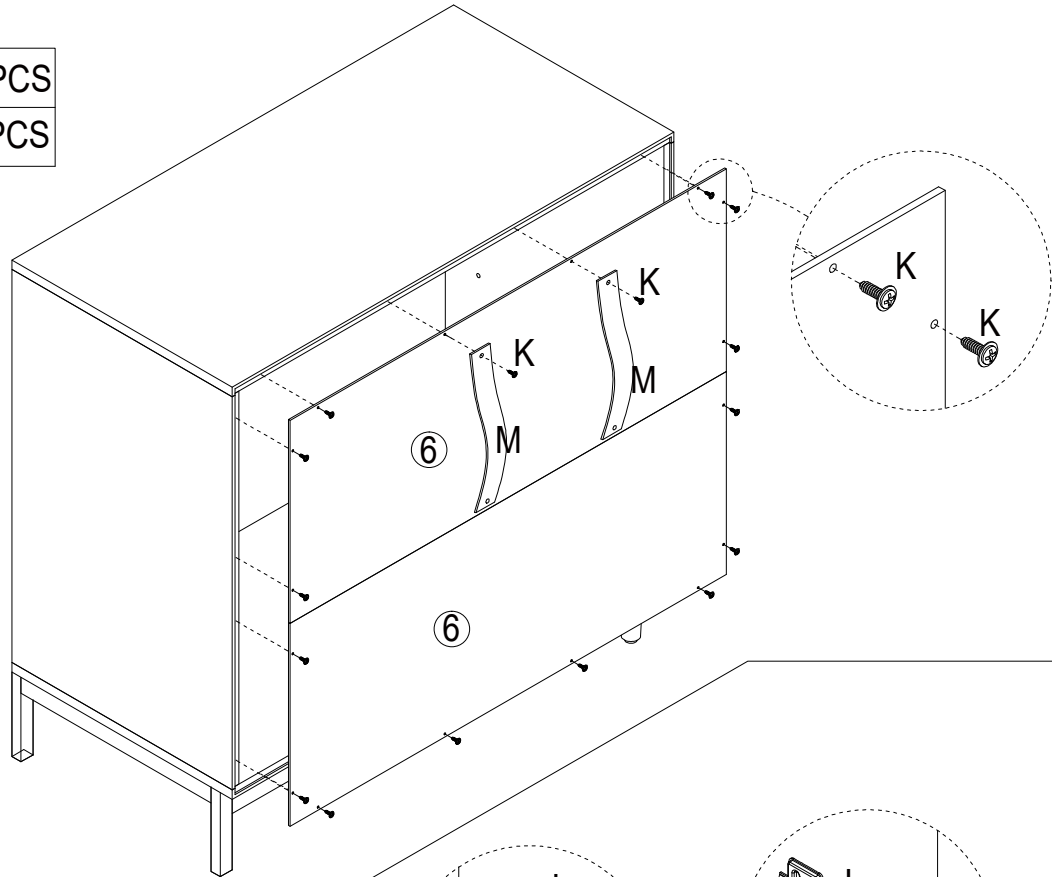

# ASSEMBLY INSTRUCTIONS

## STEP 3

K:		20PCS
M:		2PCS



## STEP 4

G:		2PCS
H:		4PCS
I:		4PCS
J:		8PCS

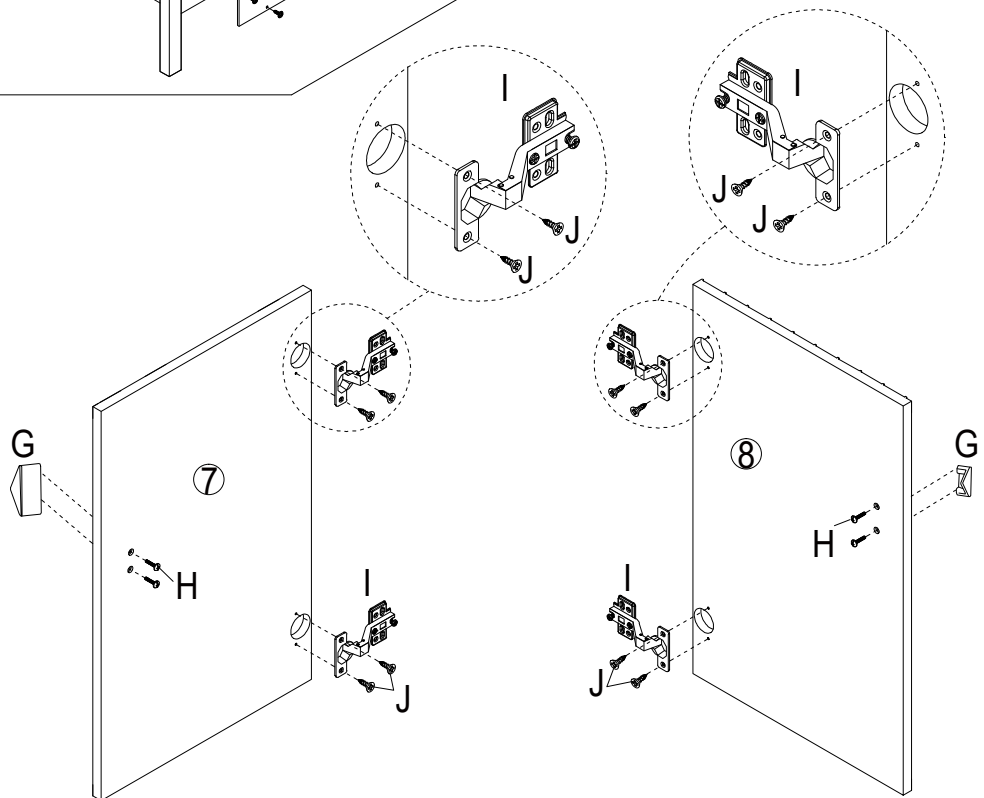

# ASSEMBLY INSTRUCTIONS

## STEP 5

J:  16PCS

To adjust door width: Loosen screws on Part I (Door hinge fitting), shift door left/right, then retighten with Part J (Round head screw).

To adjust door height: Adjust the vertical position of Part I and secure with Part J to ensure the door is level with the cabinet frame.

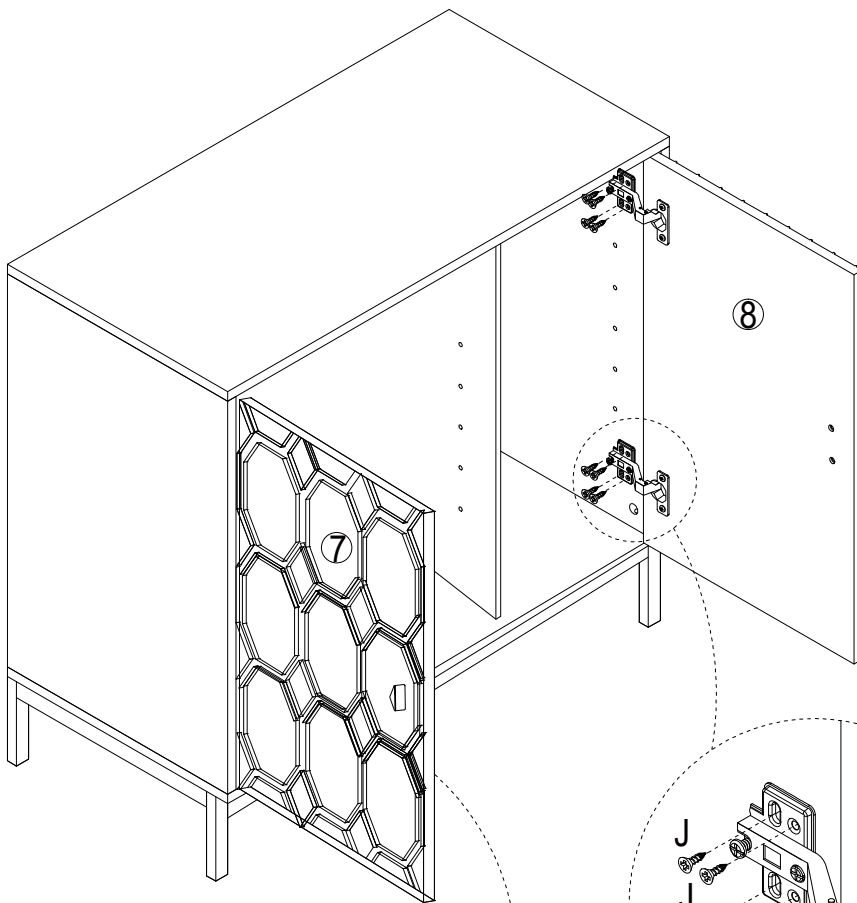

## DOOR FITTING

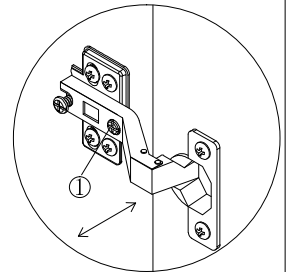

To adjust in width

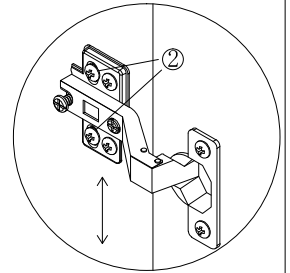

To adjust in height

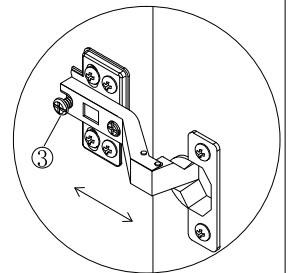

To adjust in depth

## ASSEMBLY INSTRUCTIONS

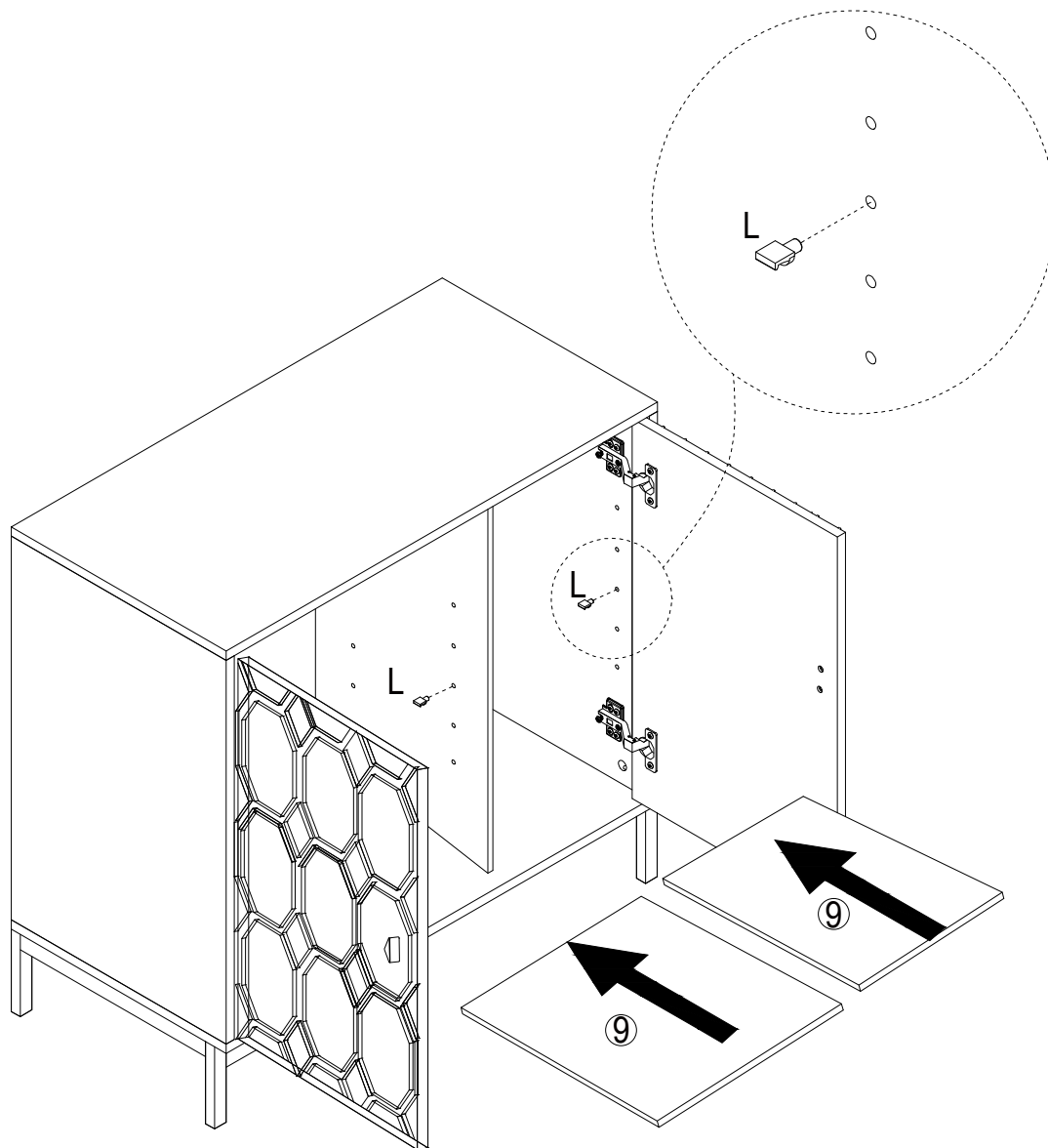

## STEP 6

L:  8PCS

Insert 8 pieces of Part L (Shelf support peg) into pre-drilled holes at desired heights, then place 2 pieces of Part 9 (Adjustable shelf) on top.

## ASSEMBLY INSTRUCTIONS

**STEP 7** Mark the wall at the height matching the pre-drilled holes on Part 6 (Back panel).

N:		2PCS
O:		2PCS
P:		2PCS

Drill a 1/8" hole, insert Plastic anchor (Part N) into the hole.

Place Washer (Part P) over Mounting screw (Part O), then drive the screw through Safety wall strap (Part M) and into the anchor. Tighten until the strap is firmly attached to the wall. Repeat for the second strap."

