

RANGEHOOD

SPECIFICATIONS

MODEL# COS-668A900



FEATURES

DESIGNED FOR WALL MOUNTING

380 CFM AIRFLOW CAPACITY

20-GAUGE, 430 GRADE STAINLESS STEEL

2 FRONT LED LIGHTS

2 ARC FLOW® PERMANENT FILTERS

65 dB. FOR QUIET OPERATION

PUSH BUTTON CONTROL PANEL

3 FAN SPEEDS

NEW DESIGN

The perfect piece for any contemporary kitchen. COS-668A900 is powered by 380 CFM of suction, 2 front LED lights and dishwasher safe ARC FLOW® permanent filters.

SEE PAGE 2 FOR DIMENSIONS



Cutout Dimension	36 Inch
Voltage	120V/60Hz
Filter Type	Permanent Filters
Mounting Type	Wall Mount
Noise Level	Max 65dB
Lighting	LED
Air Flow	380 CFM

Control Type	Push Button
Material	Stainless Steel
Wattage	200 W
Vent Style	External
Additional	Bulb(s), Damper, Exhaust Vent, Fan Hardware, Installation Kit, Power Cord,

RANGEHOOD

MODEL# COS-668A900

DIMENSIONS

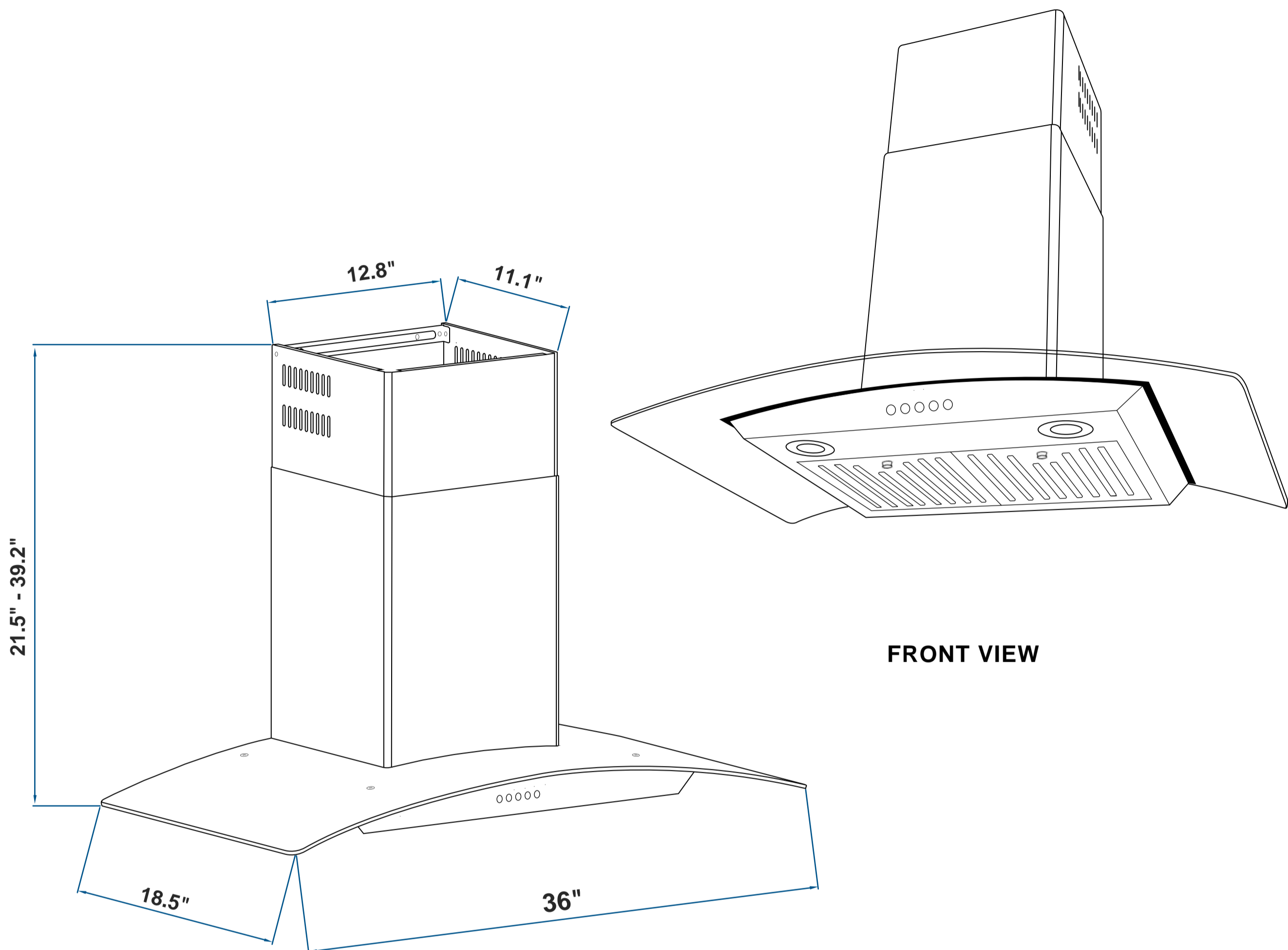

FRONT VIEW

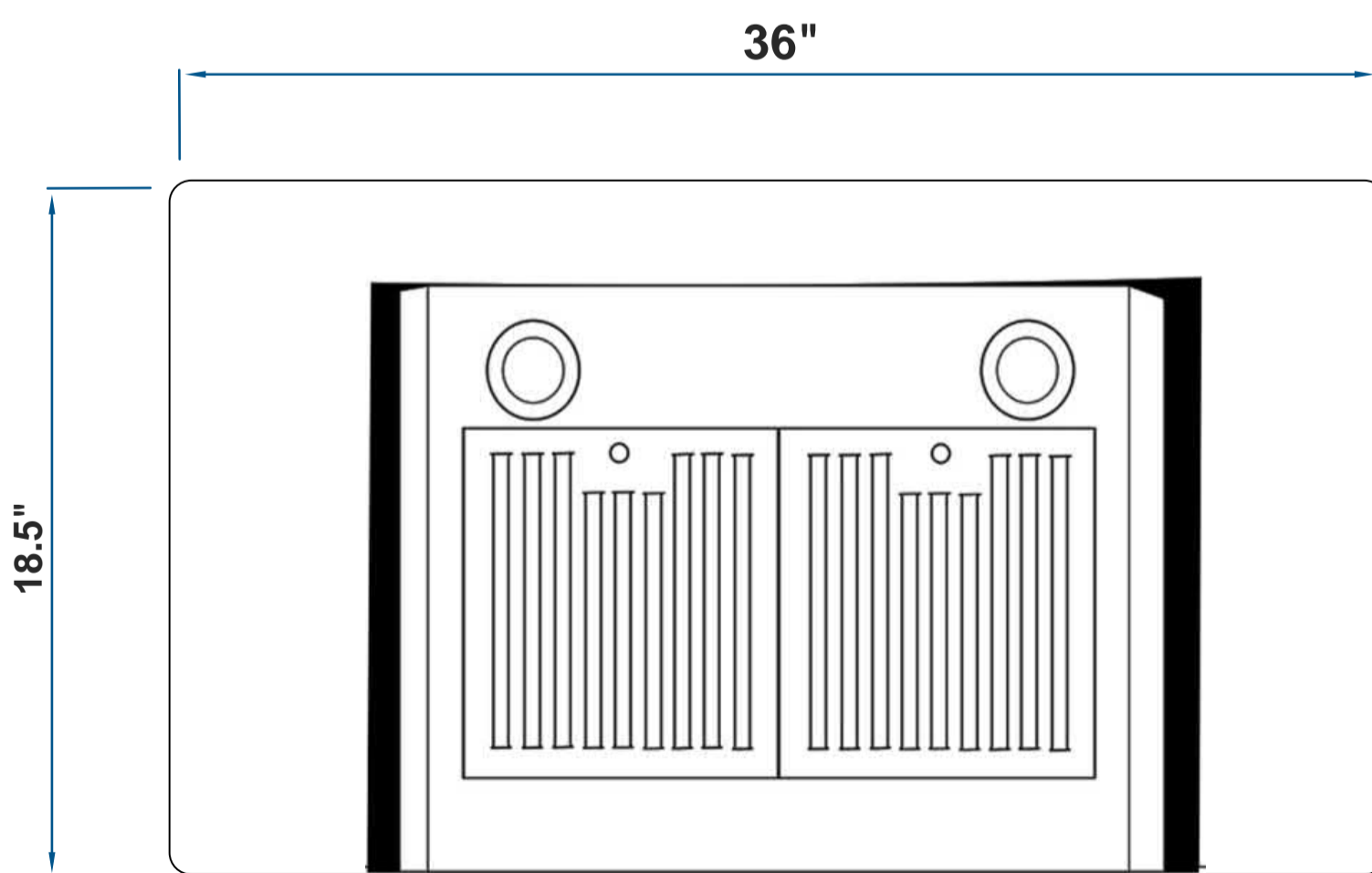

VIEW FROM UNDER